

LAZY TONGUE RIVETER

USER INSTRUCTION

Item No. 10461

Specification:

Working stroke: 10mm
 Suitable range: core pulling riveting for materials, such as steel
 Setting rivet diameter: 2.4mm, 3.2mm, 4.0mm, 4.8mm, 6.4mm

Usage & Adjustment:

1. Choose the rivet, then choose relative nozzle (1) according the specification of the rivet. The specifications of the nozzles are $\Phi 2.4$, $\Phi 3.2$, $\Phi 4.0$, $\Phi 4.8$, $\Phi 6.4$ mm Tighten the nozzle to the gun shield(2) the rivet bar should slide freely in the hole.
2. Put the nozzle upside down, hold the gun body(10), with one hand, pull the handle backward with other hand, then insert the chosen rivet into the hole, the rivet bar should be inserted to the three claws (5) smoothly . Don't over tighten and must not be loose. Adjustment Method: Loosen the locking nut (3) rotate the gun shield (2) clockwise to tighten (anticlockwise to loosen), pull out the handle grip to extend the Riveter and to tighten the three claws. Now re-tighten the locking nut (3) to secure.
3. For components which need to be riveted, the hole diameter must be 0.1mm bigger than the outer diameter of the rivet body, the hole must be vertical with the component.
4. Operation: Insert the rivet to the hole of the component, fully extend the riveter by pulling out the handle. Insert fully the nozzle into rivet bar and make sure the nozzle is vertical to and in the component, push the handle to make the rivet expand, then tighten the component. If the rivet bar has not broken, you can push and pull the handle several times until the rivet fully sets and the rivet bar breaks.
5. Extend the rivet gun by pulling on the handle and point the nozzle of the rivet gun downwards and the rivet bar should come out.
6. It is required to check the locking nut (3) and re-tighten regularly while using.
7. The three claws can wear or break while using. If this happens then the complete Riveter should be replaced.

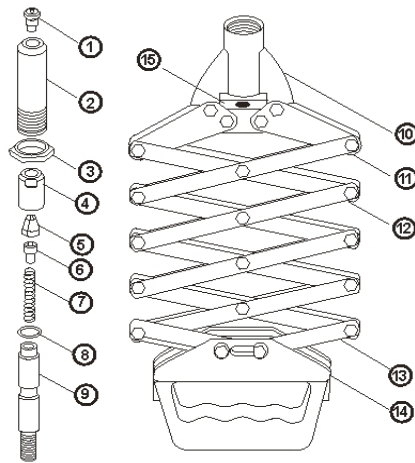

NO.	NAME	NO.	NAME
1	Nozzle	9	Gun core
2	Gun Shield	10	Gun body
3	Locking nut	11	Connecting plate
4	Tighting sleeve	12	Long support
5	Three claws	13	Short Support
6	Top Core	14	Handle
7	Spring	15	Connecting Block
8	Oring(18 x 2.4)		

140 x 210 mm 單一色 K