

THERMOSET TOILET SEAT - ADJUSTABLE STAINLESS STEEL HINGE

FITTING INSTRUCTIONS

Please read carefully before you start and retain for future reference

Please read carefully before attempting to fit the seat. If you are not the end user, please make sure the aftercare instructions are made available for the end user to read.

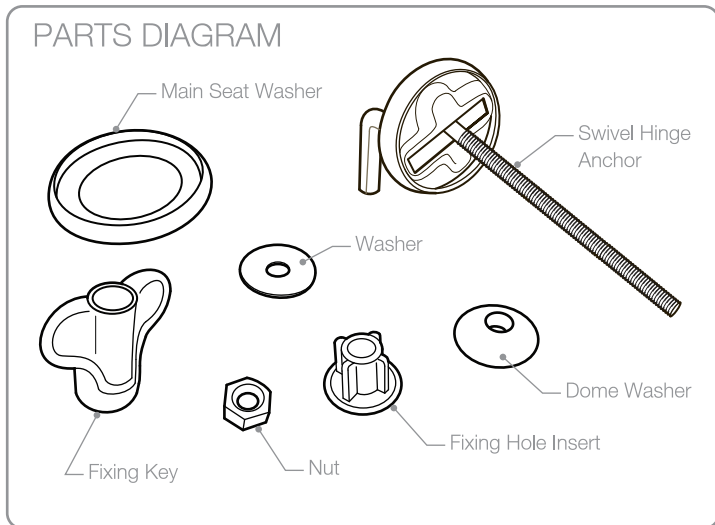

The seat is supplied with the above fixing kit (2x of each component except Fixing Key))

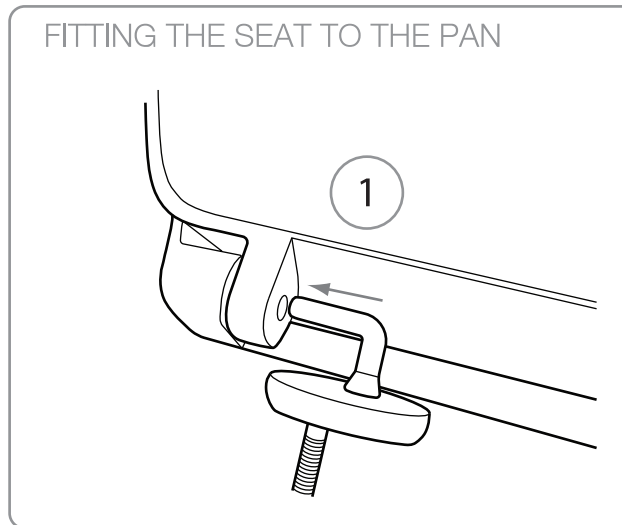

Insert the swivel hinge into the seat fixing hole at the rear of the ring/lid as shown in diagram above (Stage 1). Bolt the seat to the pan using the fixings in the configuration shown in diagram above (stage 2). To adjust the seat position to align with the pan see adjustment below. Once seat is in desired position fully tighten the nut using the fixing key supplied.

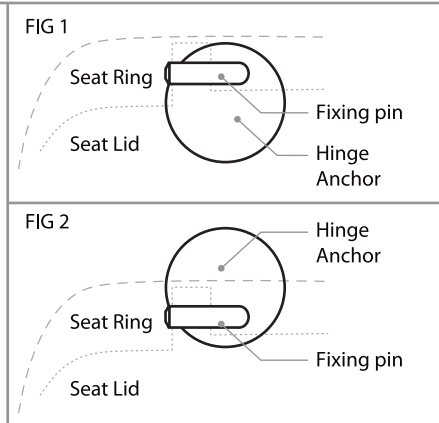
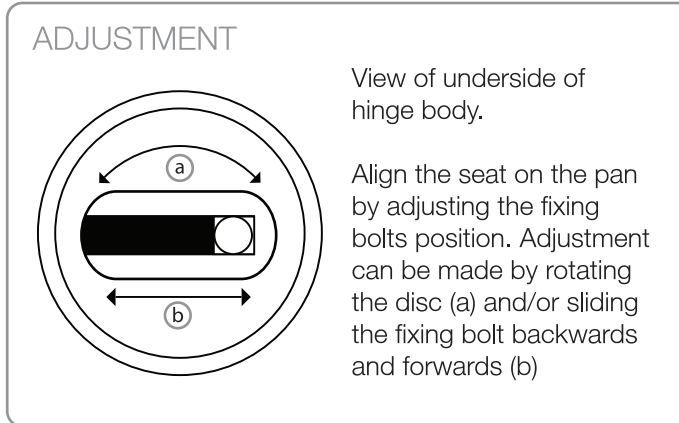
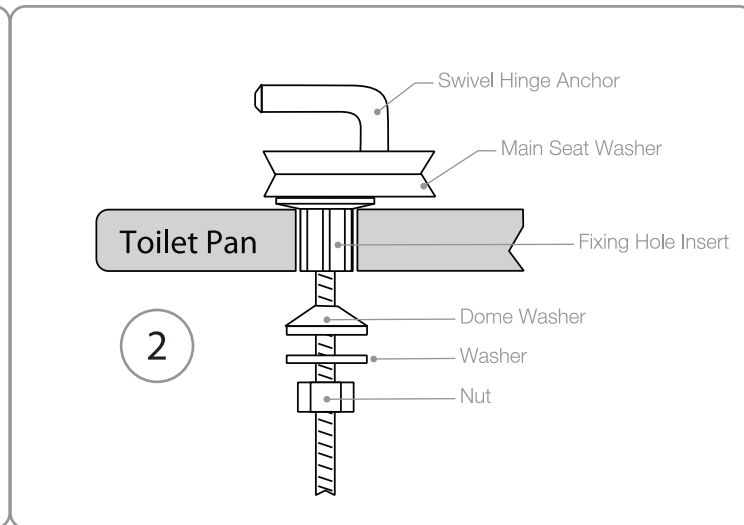

For minimum seat projection fit the hinge anchors as shown in Fig. 1.

For maximum seat projection fit the hinge anchors as shown in Fig. 2.

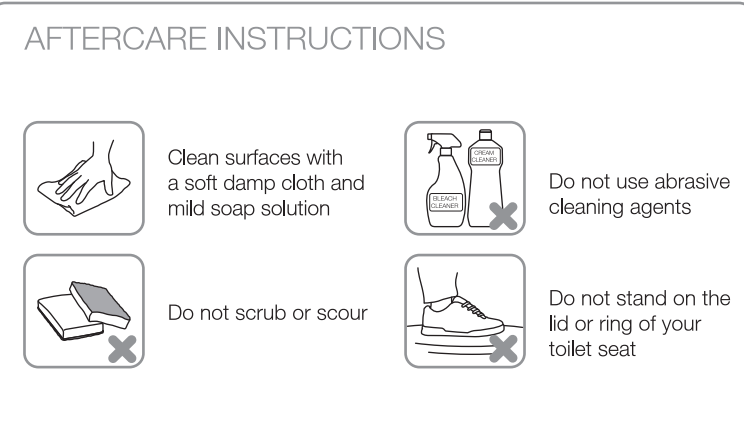

CUSTOMER SERVICES

Brassmill Lane Trading Estate, Bath BA1 3JF | tel: 01225 303900

REF: RR.WL.06.12