

GASUIT5 3663602842071

V40522 BX220IM/B3

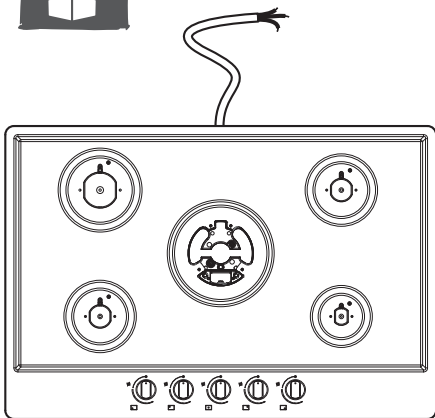

IMPORTANT - Please read carefully the separate safety guide before use.

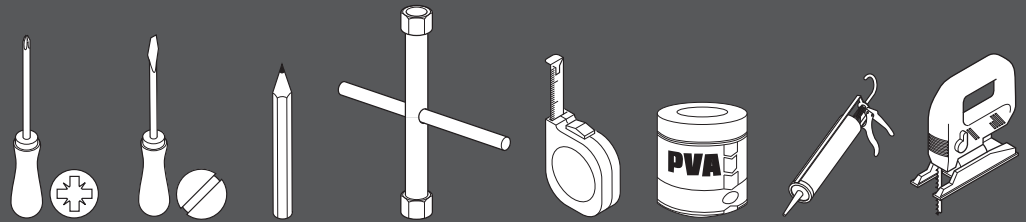
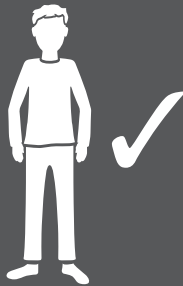

[01] x1

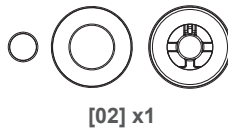

[02] x1

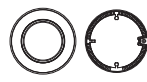

[03] x1



[04] x2



[05] x1

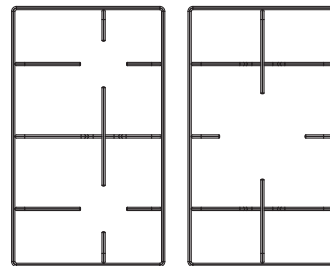

[06] x2

[07] x1

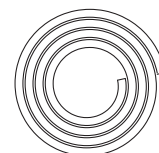

[08] x1



[09] x4

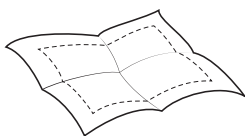

[10] x1

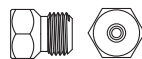

[11] x5
(G30 28-30 mbar)

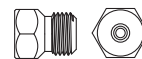

[12] x5
(G31 37 mbar)

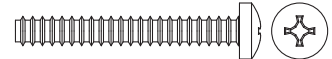

[13] x4
(4 x 40mm)



Installation

4



Use

13



Care & maintenance

15



Installation

Caution:

The connection of the hob to the gas network or gas cylinder must be made by means of a rigid copper or steel pipe with fittings complying with local regulations. These fittings are NOT supplied.

THIS OPERATION MUST BE MADE BY A QUALIFIED GAS INSTALLER

NOTE:

- The use of a gas cooking appliance produces heat and humidity in the place where it is installed.
- Therefore, you need to ensure the place is well ventilated, keeping the natural ventilation openings clear and use a cooker hood for extraction.
- Intensive or prolonged use of the appliance may require additional ventilation including opening a window.
- This appliance is only for flat bottomed pans.

This appliance is to be used for the preparation of food and drink only, and must not be used as a source of heat. Doing so may result in carbon monoxide poisoning and overheating of the hob.

Gas supply requirements

This hob is delivered pre-installed with gas jets (G20 : 20 mbar) suitable for natural gas. For use with other gases, please consult the injector table later in these instructions.

Note: any change of jets **MUST** be carried out by a qualified gas installer only.

After completing the installation, ensure there is a gas tight seal around the bottom of all injectors using foam. Press on the injector with your finger so that the gas outlet is closed and check for any bubbles on the connection areas of the injectors.

Prior to installation, ensure that the local gas distribution and pressure are compatible with this appliance.

Ventilation

This appliance must not be connected to a combustion products evacuation device. It shall be connected and installed in accordance with local installation regulations paying particular attention to the relevant requirements regarding ventilation.

What to do if you smell gas?

Do not try to light any appliance.

Do not touch any electrical switch.

Do not use phones in the building.

Immediately call your gas supplier from a different property.



WARNING: Read the instructions before using the appliance.

THIS APPLIANCE MUST BE EARTHED.

THIS HOB MUST BE INSTALLED BY A QUALIFIED GAS TECHNICIAN!

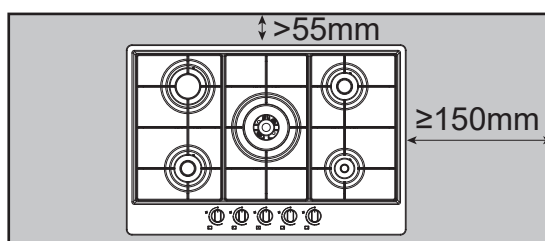
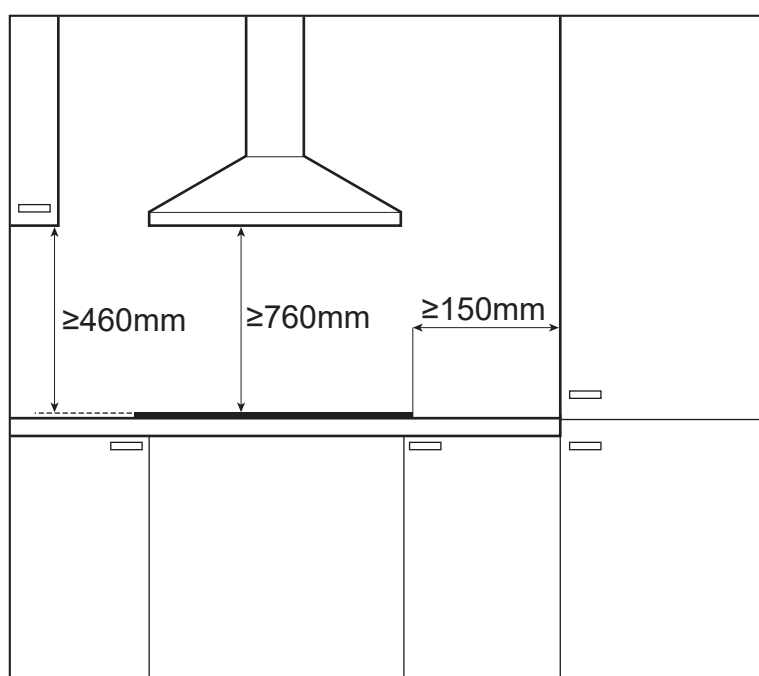

Warning: Good ventilation is required around the appliance for easier dissipation of heat and low power consumption. Sufficient clearance is required around the appliance as shown in the diagrams above. The gap between the hob and any cupboard or extractor above it must be at least 760mm.

Do not install this appliance within 300mm of a window or a sink.

02

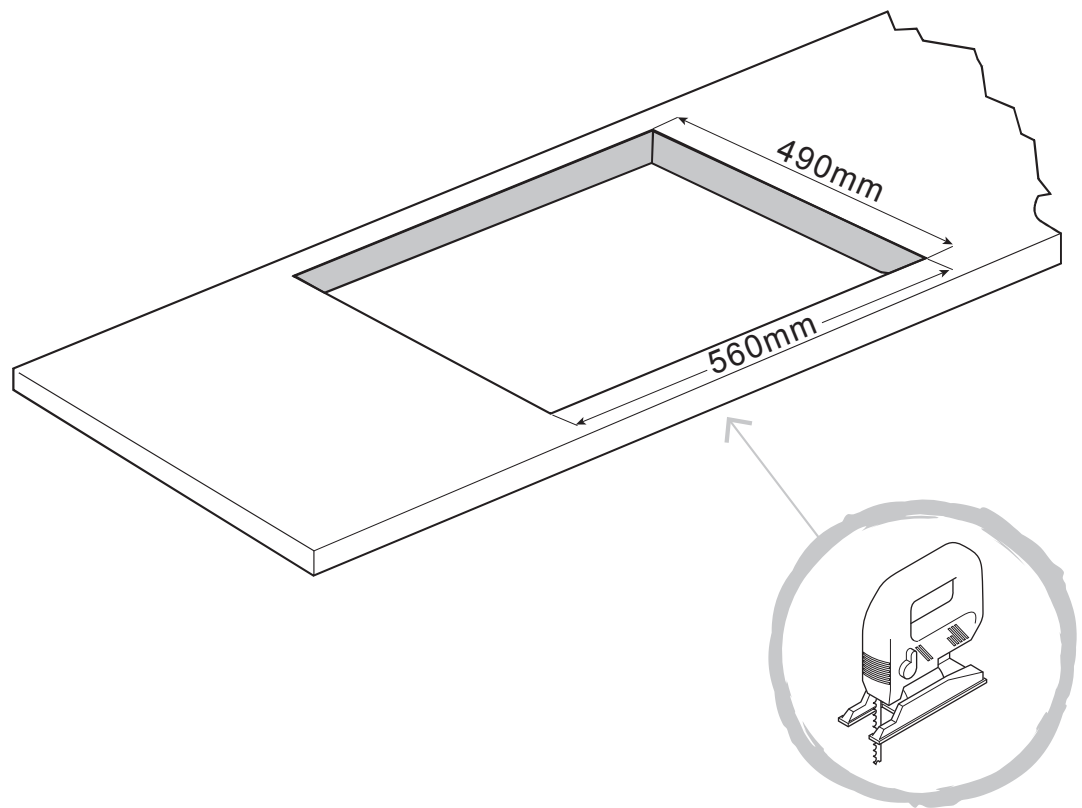
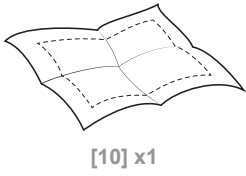

Cut an aperture in the worktop using a jigsaw as shown. The worktop should be at least 30mm thick and made of a heat resistant material.

03

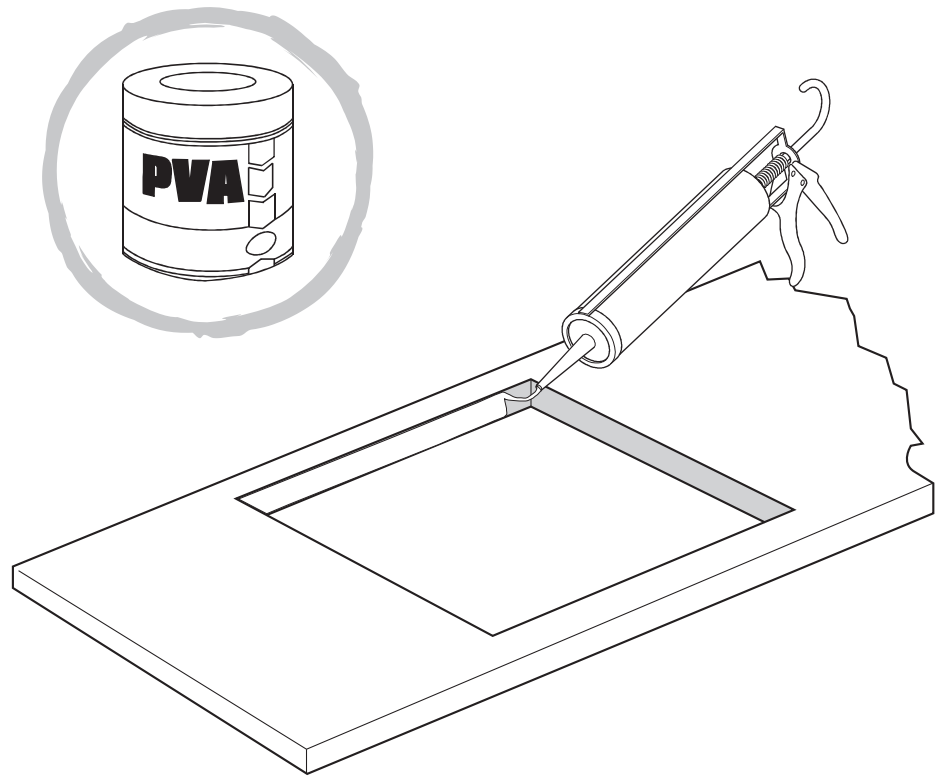

Seal the cut edge of the worktop using silicone sealant or PVA adhesive.

IMPORTANT: ensure that either product is fully cured as per the manufacturer's instructions before you commence installation of the hob. This hob **MUST NOT** be sealed or bonded into the worktop.

04

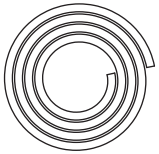

[08] x1

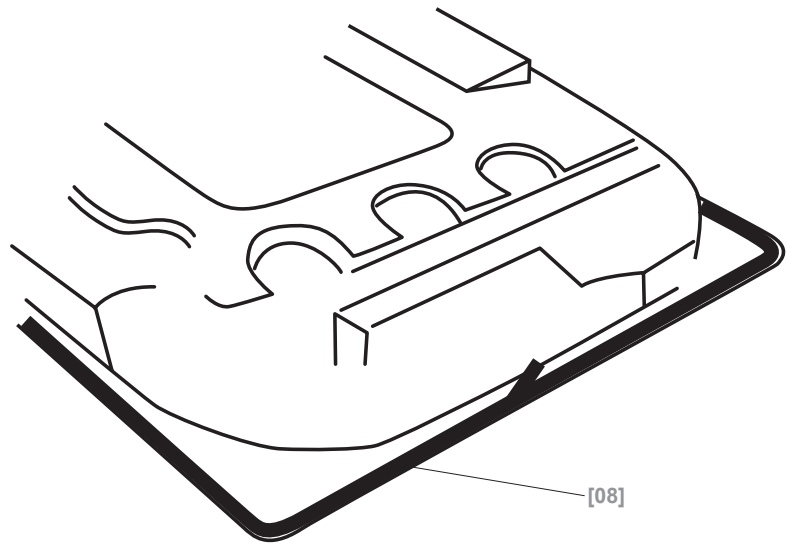

Stretch out the supplied seal along the underside edge of the hob, ensuring the ends overlap.

05

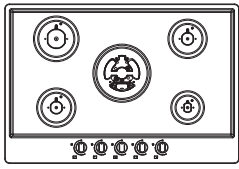

[01] x1

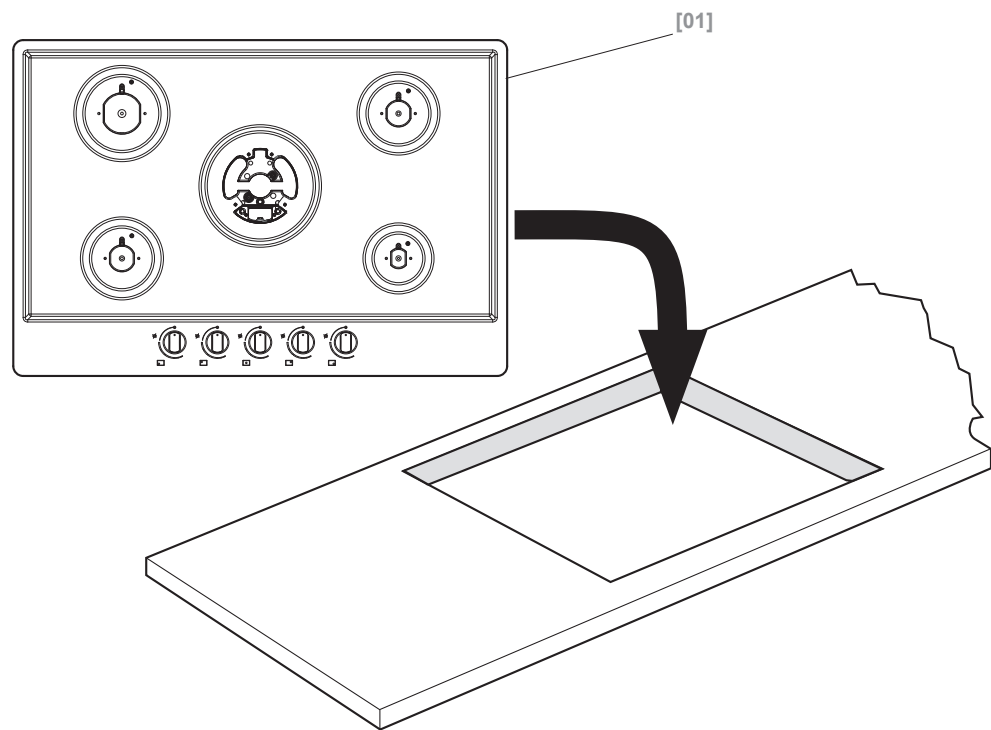

Once the worktop edge has cured, and the tape is fitted, position the hob into the cutout in the worktop.

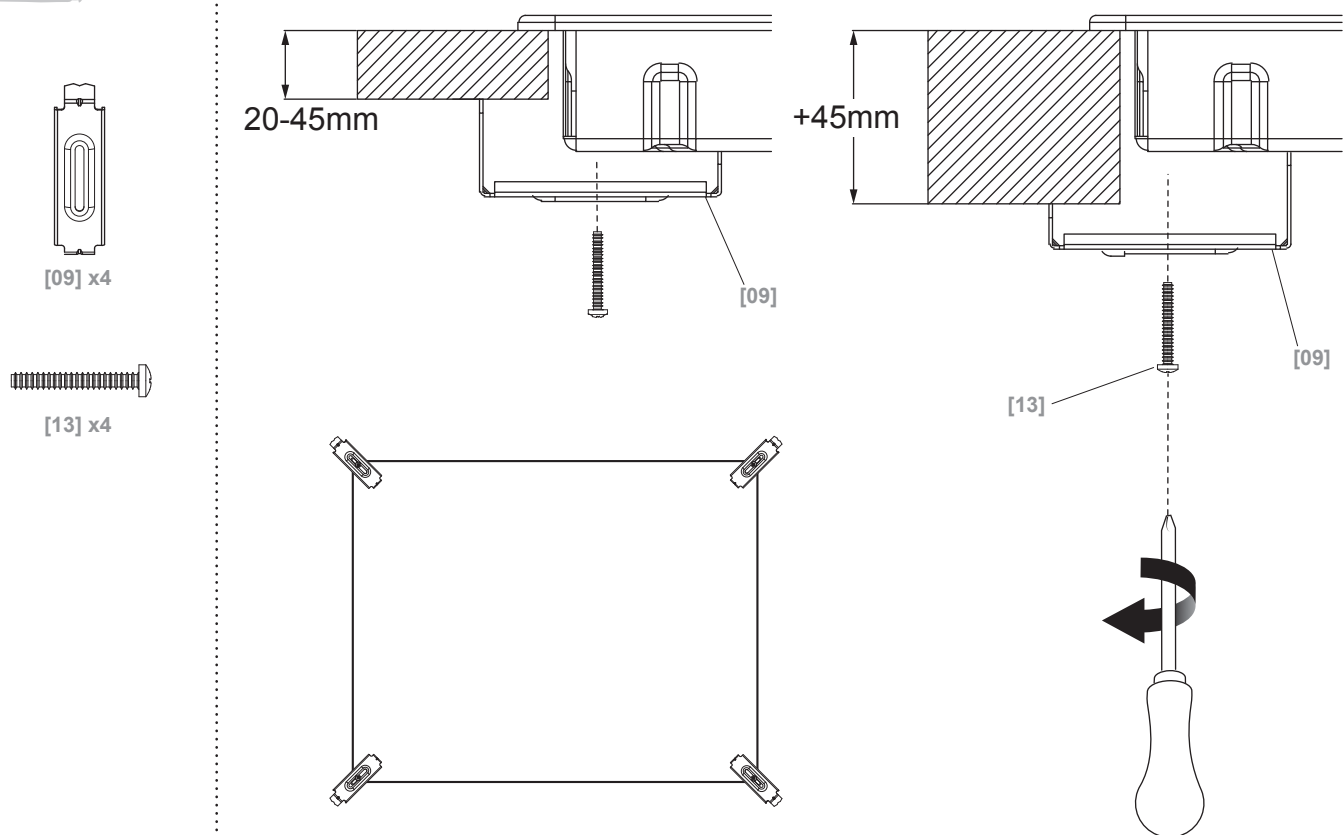

Secure the hob to the worktop by attaching the brackets as shown.

Connection to the gas supply

THE CONNECTION TO THE GAS SUPPLY MUST ONLY BE MADE BY A QUALIFIED GAS INSTALLER

- The connection of the hob to the gas pipe network or gas cylinder must be made by means of a rigid copper or steel pipe with fittings complying with local regulations.
- A connecting elbow is pre-fitted to the hob. This elbow terminates in an external 1/2" BSP connecting thread complying with ISO 228-1:2003. The connection made to the pre-fitted elbow MUST be suitable for connecting to this thread. If ANY other connection type or thread size is used a suitable adaptor MUST be fitted.
- The qualified gas installer must ensure that the operation of the burners has been correctly verified before use.

Adjustment to a different type of gas

Caution: replacement of gas jets must only be carried out by a qualified gas installer.

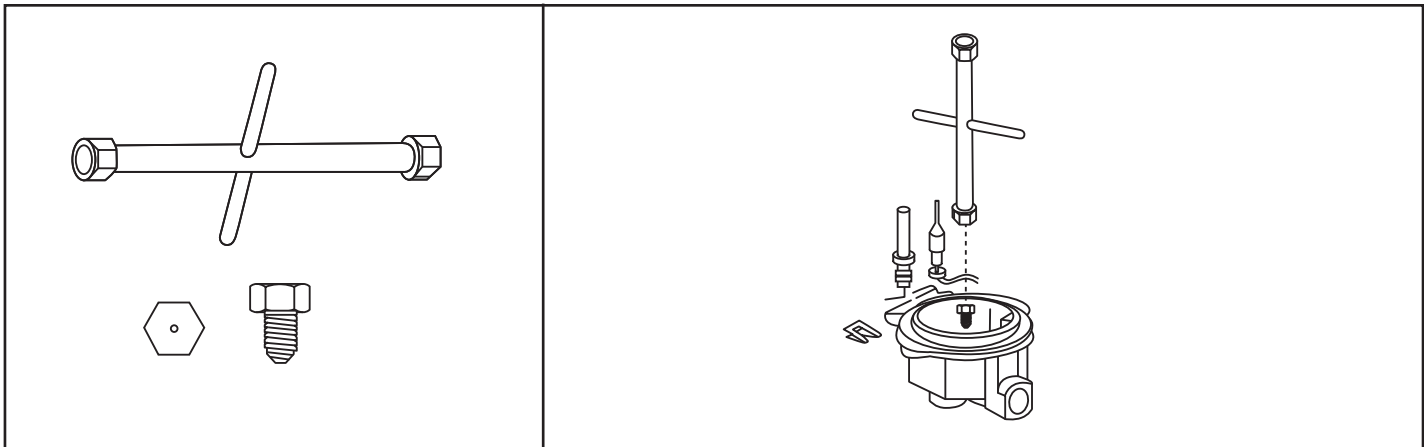

Note: Extra gas jets are supplied to enable conversion for use with different gas types including liquid petroleum gas (LPG) butane and propane. Details of the extra jets supplied and their applications can be found in the Injector Table printed later in this manual. These jets must be replaced using a dedicated specialist tool, not supplied.

Regulation of burners

Caution: The regulation described can only be carried out with burners that use methane gas and city gas (where available), and the screw must be fully tightened in a clockwise direction on burners using LPG.

Caution: The Minimum position on the burners **MUST** be adjusted by a qualified gas engineer only.

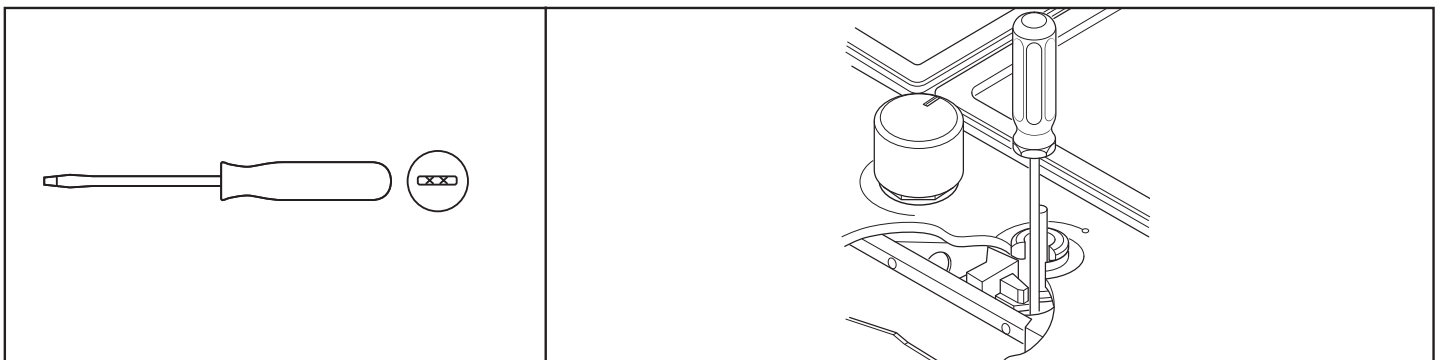

Regulation of the “MINIMUM” position on the burners.

To regulate the minimum position on the burners, follow the procedure below:

1. Turn on the burner and turn the knob to its MINIMUM position (small flame).
2. Remove the burner knob and turn the fixing screw to the right or left until the flame of the burner is regulated in the most suitable manner to MINIMUM and remains stable.
3. Make sure that the flame does not go out when changing the position quickly from MAXIMUM to MINIMUM position.

Connecting to the electrical supply

All installation must be carried out by a qualified electrician. Before connecting the mains supply ensure that the mains voltage corresponds to the voltage on the rating plate.

Direct Connection

The appliance must be connected directly to the mains using an omnipolar circuit breaker with a minimum opening of 3 mm between the contacts.

The installer must ensure that the correct electrical connection has been made and that it complies with the wiring diagram.

The cable must not be bent or compressed.

Regularly check the power cord for damage. If the supply cord becomes damaged, it must be replaced by the manufacturer, its service agent or similarly qualified persons in order to avoid a hazard.

WARNING: This is a Class I appliance and MUST be earthed.

This appliance is supplied with a 3 core mains cable coloured as follows:

Brown = L or Live

Blue = N or Neutral

Green and Yellow = E or Earth 

This appliance should be connected directly to the consumer unit with a 3 Amp Residual Current Device (RCD) protecting its circuit.

To avoid the risks that are always present when you use an electrical appliance it is important that this appliance is installed correctly and that you read the safety instructions carefully to avoid misuse and hazards. Please keep this instruction booklet for future reference and pass it on to any future owners. After unpacking the appliance please check that it is not damaged. If in doubt, do not use the appliance but contact Customer Services - see end of Care & Maintenance section for details.



Use

Before you start

Switch on the appliance at the switched fused connection unit. The appliance is ready for use.



WARNING: Read the instructions before using the appliance.

Functions and settings

- Flame safety device (FSD): Stops the gas supply to the gas hob when the flame goes out.
- Auto ignition.

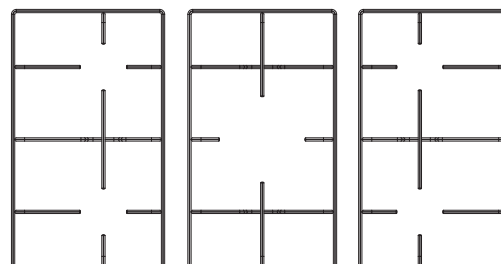
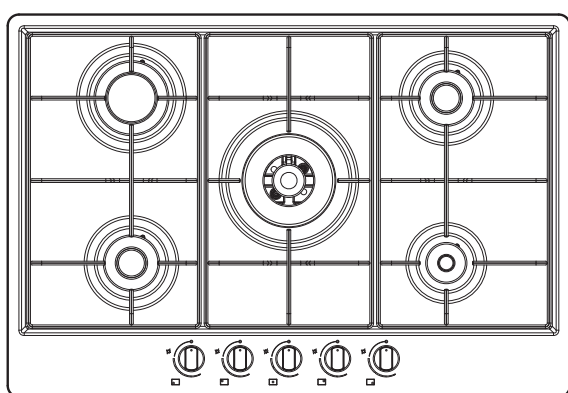

Injector Table

Gas Category UK & IR

II2H3+ (G20 20 mbar, G30 28-30 mbar, G31 37 mbar)

Type of gas used	Type of burner	Injector marking	Rated thermal flow rate kW	Rated consumption	Reduced heat capacity kW	Gas Pressure rating (mbar)
NATURAL GAS (Methane) G20	Auxiliary	0.72	0.95	91 lt/h	0.45	20
	Semi Rapid	0.97	1.75	167 lt/h	0.60	
	Rapid	1.15	2.90	276 lt/h	0.90	
	Triple Crown	1.50	3.80	362 lt/h	1.65	
LIQUEFIED PETROLEUM GAS (Butane) G30	Auxiliary	0.50	1.00	73 g/h	0.45	28-30
	Semi Rapid	0.65	1.75	127 g/h	0.60	
	Rapid	0.85	2.90	211 g/h	0.90	
	Triple Crown	1.01	4.00	291 g/h	1.65	
LIQUEFIED PETROLEUM GAS (Propane) G31	Auxiliary	0.50	1.00	71 g/h	0.45	37
	Semi Rapid	0.65	1.75	125 g/h	0.60	
	Rapid	0.85	2.90	207 g/h	0.90	
	Triple Crown	1.01	4.00	286 g/h	1.65	

Type of gas used	Model configuration 5 BURNERS	Rated thermal flowrate (kW)	Total rated consumption
G20 20 mbar	1AUX – 2SR – 1R – 1TC	11.15	1063 lt/h
G30 28-30 mbar	1AUX – 2SR – 1R – 1TC	11.40	829 g/h
G31 37 mbar	1AUX – 2SR – 1R – 1TC	11.40	814 g/h

Burner	Minimum Pan Diameter (cm)	Maximum Pan Diameter (cm)
Auxiliary	≥10	≤16
Semi Rapid	≥14	≤18
Rapid	≥16	≤22
Triple Crown	≥20	≤24

Operation

Burner operation

- Push and turn the knob around to the spark zone of the control until the gas lights.
- Reduce the gas level to suit the cooking required.
- If the gas fails to light first time, please try again.

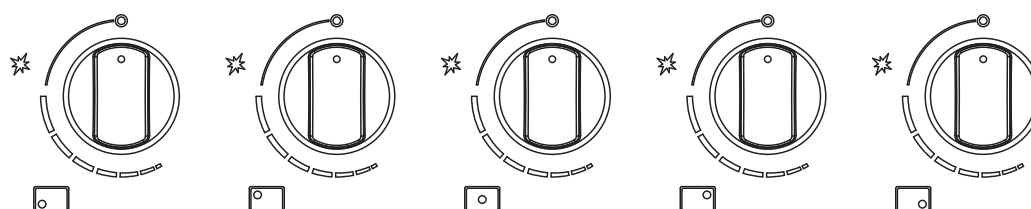

CAUTION:

- If there is no electric current you can light the burners with a piezo electric spark gas ignitor.
- The burners can only be lit with safety thermocouples when the knob is on MAXIMUM.
- Do not use cooking vessels on the hob that overlap the edges of the pan supports.



Care & maintenance



Warning: Always switch off the electricity and gas supply before performing maintenance work. In the event of a fault, contact customer services at the end of the care and maintenance section.

Caution:

- Use soapy water and a cloth for cleaning. Never use abrasive powders.
- Avoid banging pots and pans down on the hob.
- Do not leave any empty pan on the heating zone.

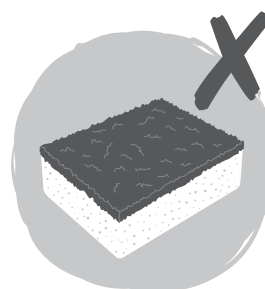
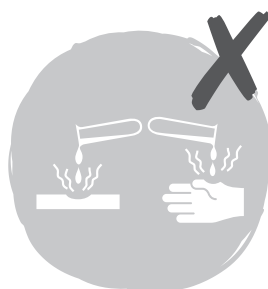
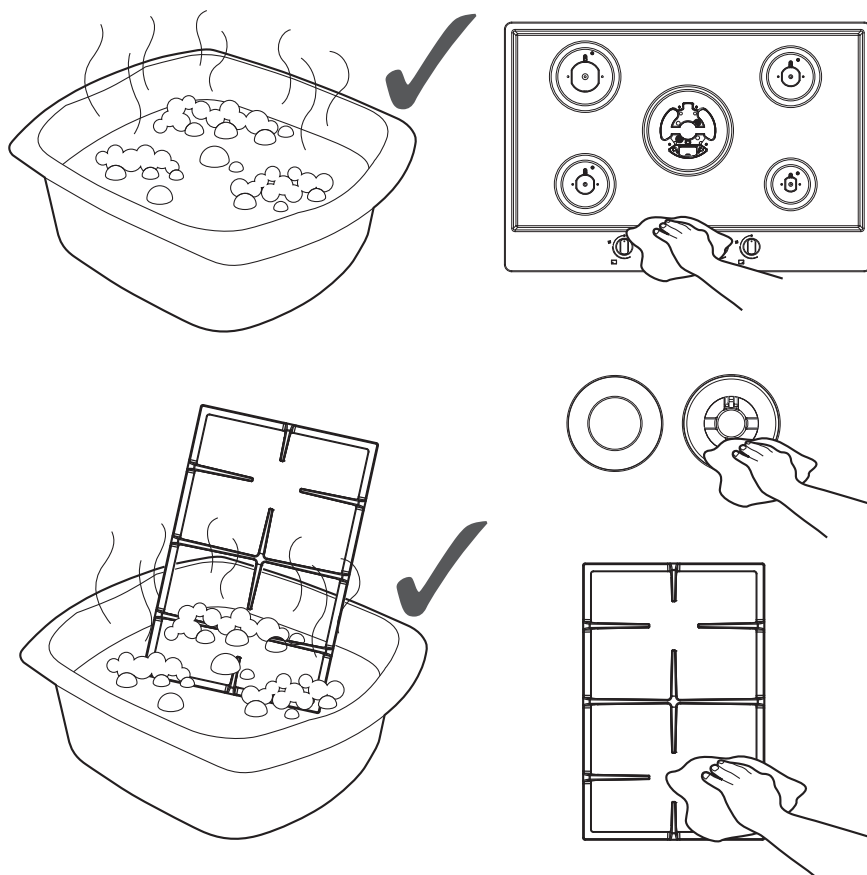
**Customer helpline (toll free):**

UK 0800 324 7818 uk@kingfisherservice.com

Eire 1-800 932 230 eire@kingfisherservice.com



Manufacturer:

UK Manufacturer:

Kingfisher International Products Limited,
3 Sheldon Square, London, W2 6PX,
United Kingdom

EU Manufacturer:

Kingfisher International Products B.V.
Rapenburgerstraat 175E
1011 VM Amsterdam
The Netherlands
www.kingfisher.com/products

www.diy.com

www.screwfix.com

www.screwfix.ie

Customer helpline (freephone):

UK 0800 324 7818 uk@kingfisherservice.com

Eire 1800 932 230 eire@kingfisherservice.com

**To view instruction manuals online,
visit www.kingfisher.com/products**