

General Care and Safety



Please do not use corrosive cleaners or solvents or any chemical agent within the water tank. Cleaners or solvents containing chlorine or calcium hypochlorite may seriously damage the product.



The surface of the sensor should be kept clean and clear of dirt or water droplets to ensure optimum performance.



The working water temperature range for this product is 2°-45°.

Contactless Sensor Flush Kit

for Close Coupled W/Cs

Fitting Instructions

Please read completely first before commencing and retain for future reference

TR9031/TR9032

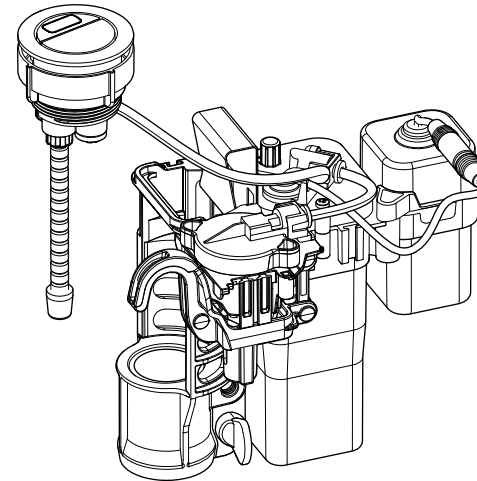

QUICK INSTALLATION GUIDE

For a quick installation guide, follow the instructional video by scanning the QR code to the right on your smart device:



Parts Included

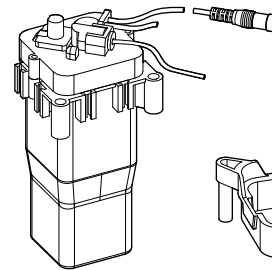

1x Control Box

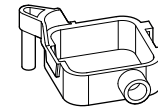

1x Battery Box Cradle



1x Battery Box

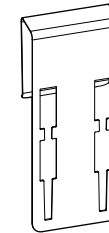

1x Stainless Steel Hanger



1x Instructional Sticker

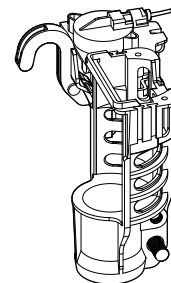

1x Clamp and Pneumatic Hook

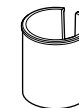

1x Clamp Collar

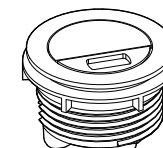

1x Button with Securing Nut

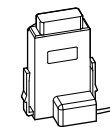

1x IR Sensor



1x Flush Button Leg

Before you start

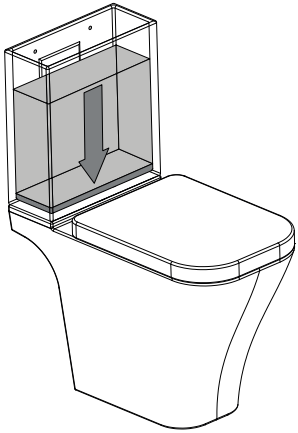

It is recommended to isolate the water supply and flush the water from the cistern before commencing installation.

Ensure that the cistern fittings are suitably arranged to allow for installation of the sensor flush kit by making the following provisions:

Make sure that the overflow tube is positioned on the opposite side of the cistern to the inlet valve

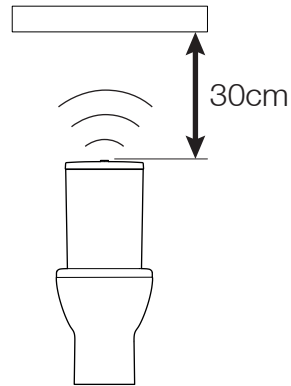
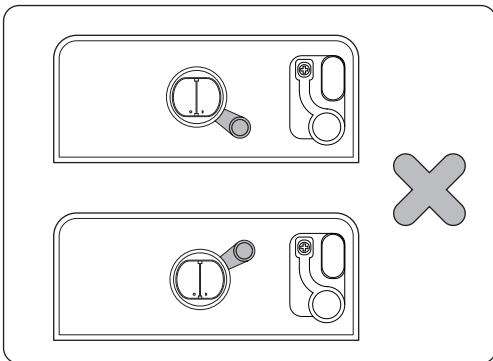
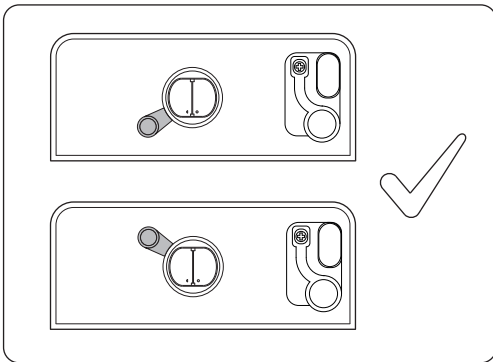

Ensure that there is a 30cm clear area above the cistern. Any obstructions such as shelves or hanging objects could trigger the sensor if positioned within this area.

Rotate the flush valve so that the REDUCED flush paddle is on the same side as the overflow tube.

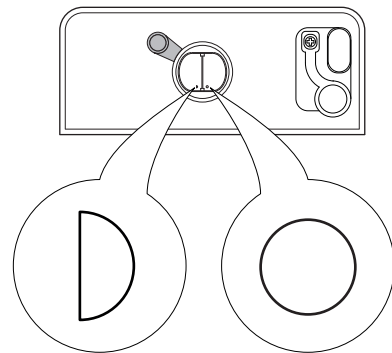

BLUE PADDLE

WHITE PADDLE

Usage Instructions

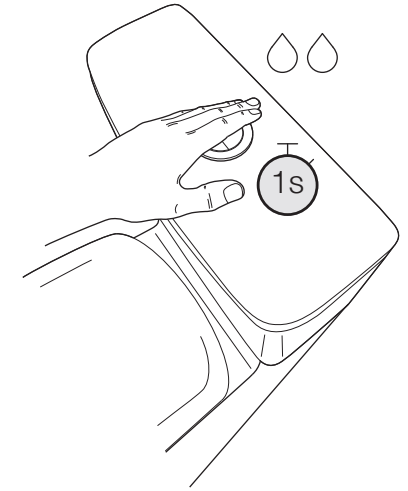
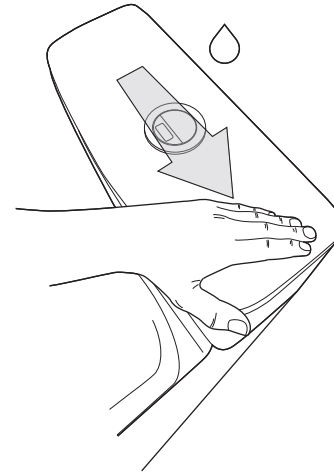

Once the installation is complete, to activate a reduced flush, wave your hand over the sensor. To activate a full flush hold your hand over the sensor for 1 second. When activated, a red light will show on the sensor.

Battery Replacement

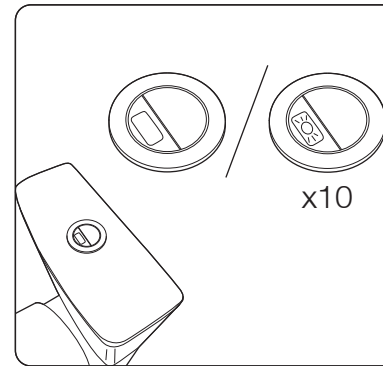

When the battery level is too low, the red indicator light on the sensor will blink for 10 seconds when activated.

The batteries must be replaced using the method shown below.

In the meantime, the full flush function can be activated using the manual flush button.

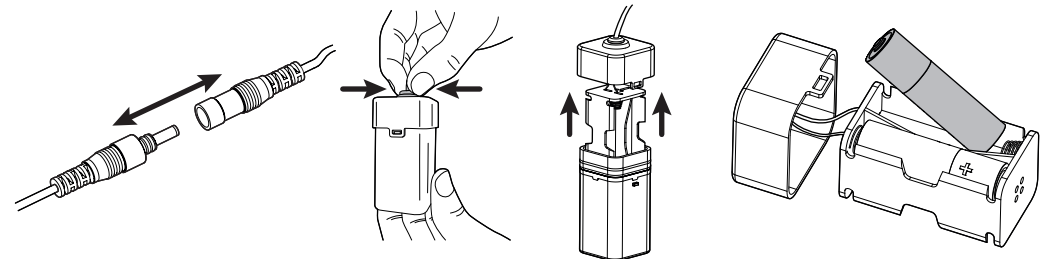
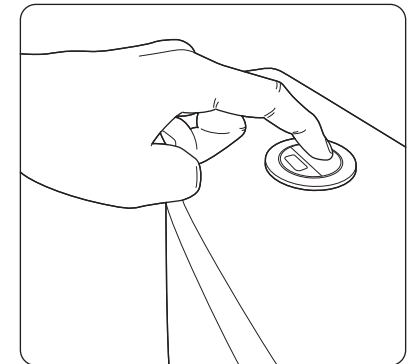

To access the battery box, first disconnect the quick connector and remove the battery box from the cistern. Next, remove the lid of the battery box making sure to squeeze the top washer to release the seal. You can now swap in new 4x1.5V AA batteries and reconnect the battery box back up to the rest of the flush unit.

5 Fitting the Flush Button

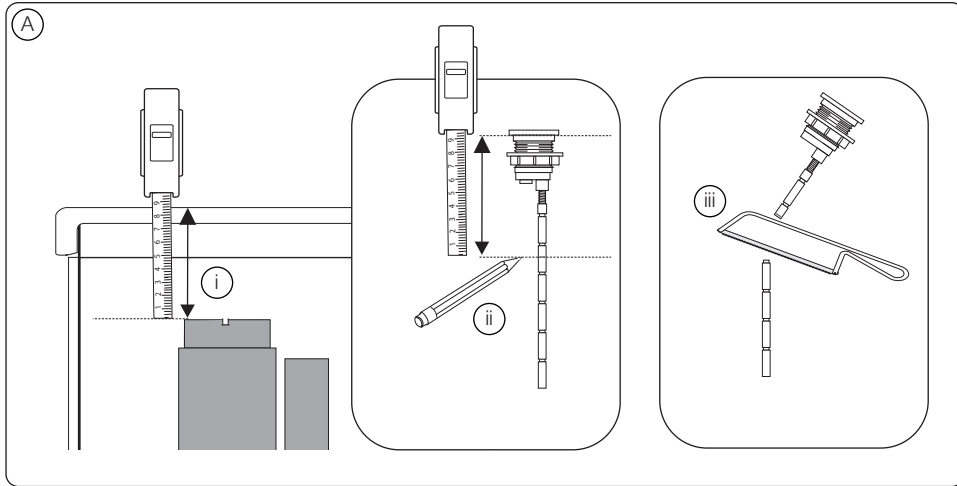

With the cistern lid on, measure the distance from the top face on the cistern to the flush valve paddles through the cistern hole. Mark this distance on the flush button leg, using the underside of button's rim as your datum point. Cut the leg down to length at the marked point.

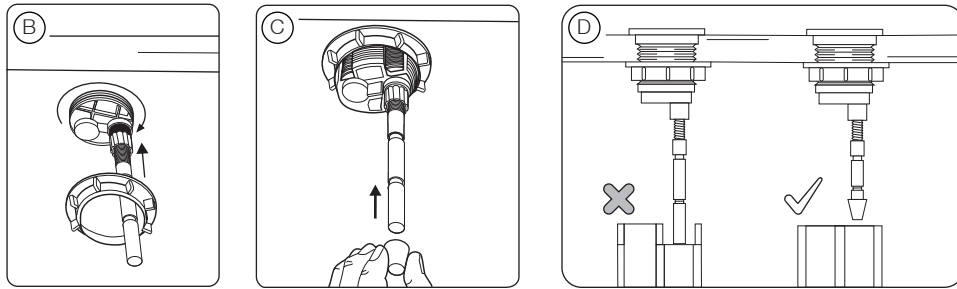

Secure the button in position by tightening the fixing nut and place the rubber bung onto the new cut end of the leg. Ensure that the leg does not press the flush paddle down whilst in its rest position. Failure to do this may cause water to constantly trickle into the WC pan.

6 Connecting up the Sensor

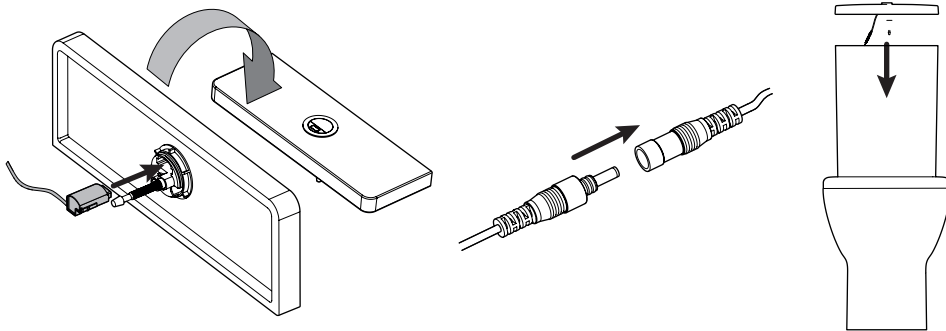

Insert the IR sensor into the slot in the bottom of the button until the locking clips engage and the sensor sits flush with the top surface of the button. To complete the installation process, connect up the battery pack's quick connector and place the cistern lid back onto the cistern.

Fitting Instructions

1 Loading the batteries

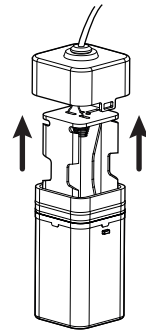

Remove the battery holder from the battery box

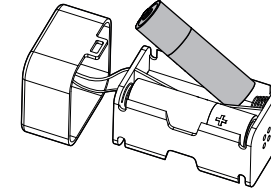

Load 4x1.5V AA alkaline batteries (supplied separately) into the battery holder

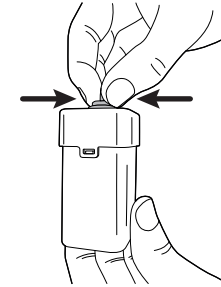

To form a seal in the battery box, squeeze the top washer until you no longer hear any air leaving the box.

WARNINGS ⚠

Non-alkaline batteries will provide a much shorter battery life.

Do not mix batteries of different brands or mix old and new batteries.

Once connected to the power, the flush system will act once to show it is working.

If you are struggling to remove the battery box lid, squeeze the top washer to release the seal.

2 Choosing flush valve orientation

The pneumatic hook and overflow clamp will be attached to the overflow tube of the flush valve so the flush valve must be oriented to have the reduced flush on the **OPPOSITE** side of the cistern to the inlet valve.

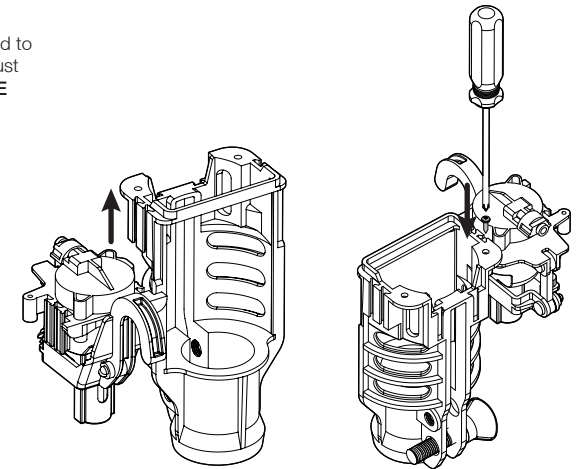
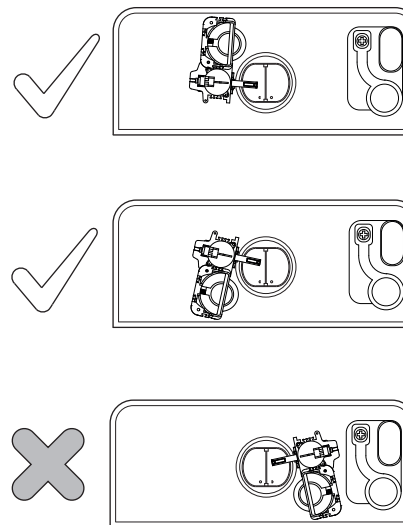

Once the flush valve is secured in position within the cistern, ensure to check which side the hook needs to be attached to the clamp so that it will sit above the reduced flush paddle. If the hook orientation needs changing from the default, detach the hook from the clamp body by unscrewing the fixing screw and sliding the clamp body upwards. Switch the connection side by using the grooves on the opposite side of the clamp body and reconnect the two parts as shown above.

3 Installing the Clamp and Pneumatic Hook

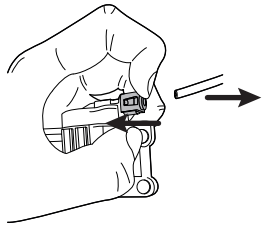

To detach the clear hose from the hook, simply press in the black connector and pull the hose out, this may make installation easier. To reattach the hose simply slide it into the connector and check it has gripped in place.

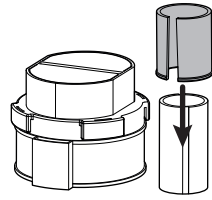

If you are using a flush valve with a slimline overflow tube, you will need to slide the overflow collar over the telescopic overflow.

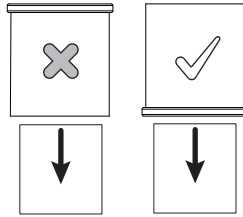

If you are using the overflow collar make sure that the lip is at the bottom when sliding on to the overflow tube, as shown above. If installed incorrectly the clamp may work loose from the overflow tube.

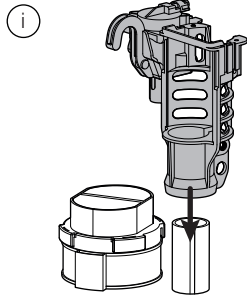

To install the clamp and hook, slide the clamp over the overflow tube.

hint
if using the collar for a slimline overflow tube ensure the collar is on the overflow tube before attaching the clamp.

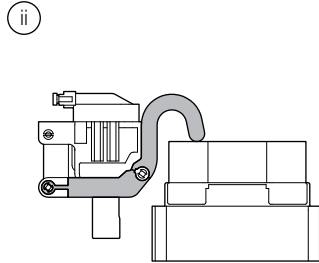

For optimum functionality, ensure that the hook is resting on top of the reduced flush paddle.

important
the hook must not press down the paddle when in its resting state or the toilet may constantly trickle.

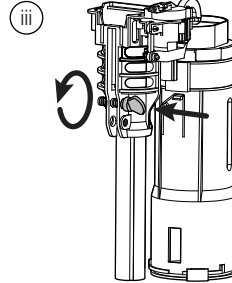

Once set in position tighten the screw to clamp the components in place

important
If using a flush valve with a telescopic overflow, check that the overflow is locked in position.

4 Installing the Control Box and Battery Box

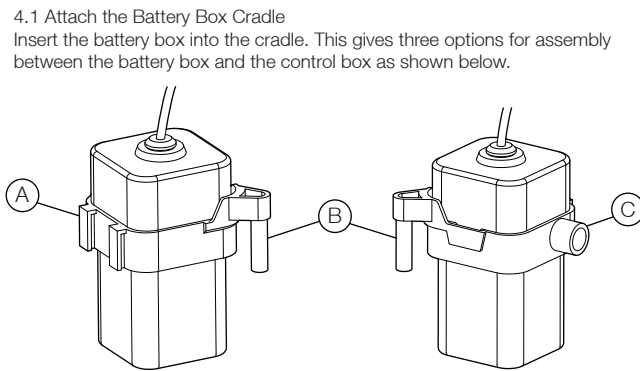
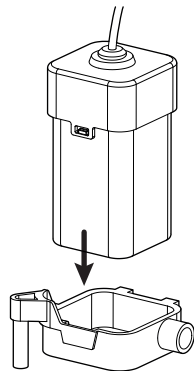

4.1 Attach the Battery Box Cradle
Insert the battery box into the cradle. This gives three options for assembly between the battery box and the control box as shown below.

4.2 Connecting the Battery Box to the Control Box

Connect the battery box to the control box using one of the three options shown below, connecting fixings A, B or C of the two parts together. The arrangement may need to be selected depending upon the room available within the cistern.

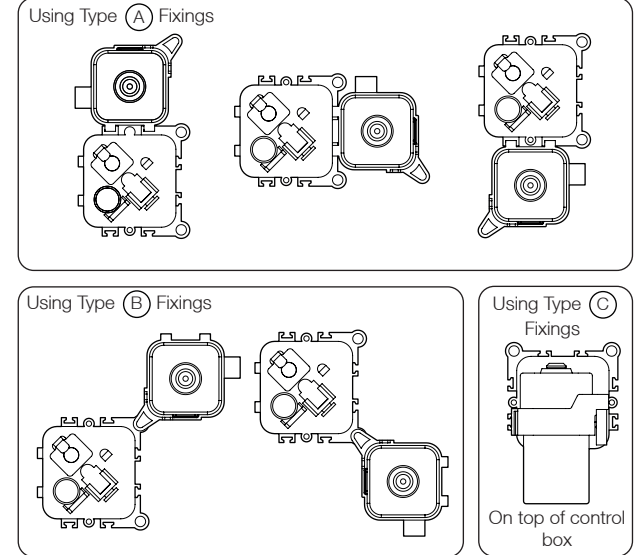
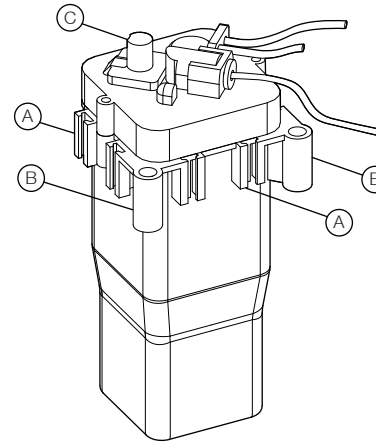

4.3 Connecting the Assembly to the Flush Valve

Using the male connecting hooks on the control box, the two components can now be connected to the flush valve assembly. Alternatively, the battery box and control box can each be attached to the back of the cistern using the stainless steel hanger. This can save room with the width or height of the overall product as the hanger allows for the boxes to be positioned lower down within the cistern.

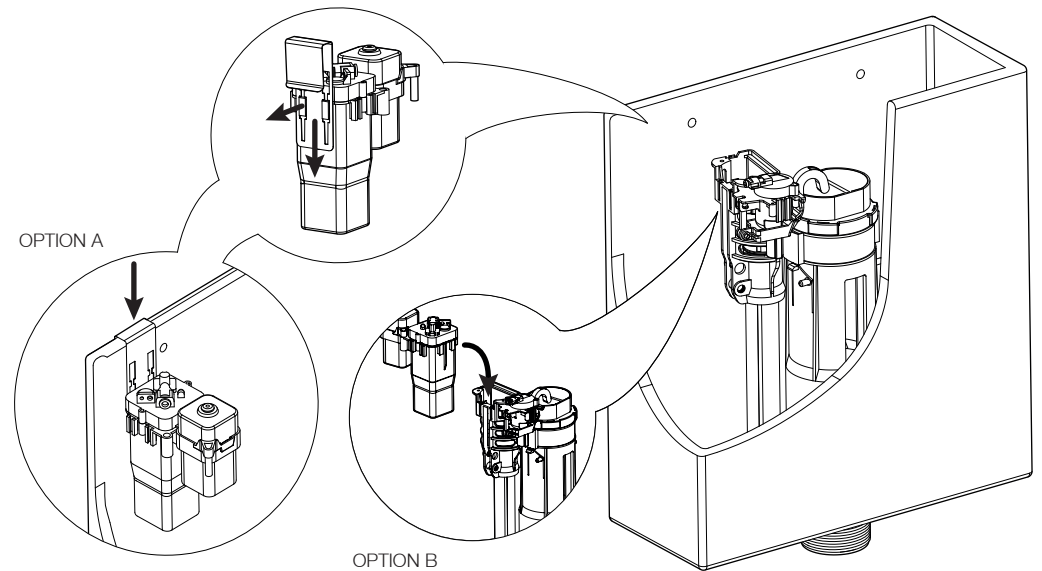



If you are struggling to find the best fit for your cistern, visit our website to view the individual step-by-step fitting guide for each of our cisterns.

Troubleshooting Guide

Contactless Cistern Sensor Flush Kit

Please retain for future reference

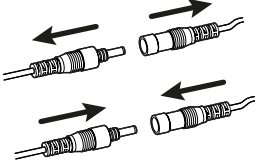
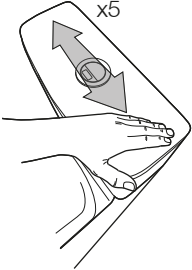
TR9031/TR9032

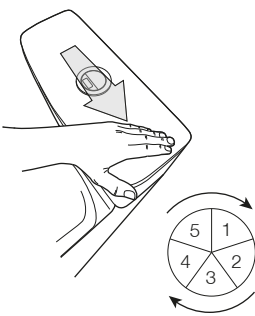
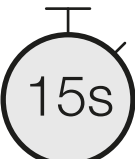
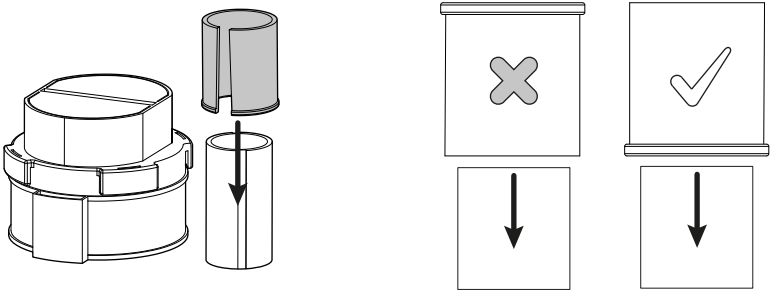
Problem	Potential cause	Suggested action
<p>The full flush is flushing too much or too little water.</p>	<p>The flush level setting needs changing.</p>	<p>Increase or decrease the flush settings level as detailed below:</p> <ol style="list-style-type: none"> <li data-bbox="662 392 1484 571"> <p>1</p>  <p>To activate the flush settings mode, first disconnect and reconnect the power via the quick release connector.</p> <li data-bbox="662 616 1452 884"> <p>2</p>  <p>Within 5 minutes of the power being reconnected, wave your hand 5 times across the sensor within 5 seconds.</p> <li data-bbox="662 929 1492 1064"> <p>3</p>  <p>The red indicator light will blink a number of times from 1 to 5. This number denotes the current flush volume setting. The default factory setting is 5.</p> <li data-bbox="662 1108 1492 1422"> <p>4</p>  <p>Each time you wave your hand over the sensor the level will increase by 1, up to a maximum of 5. After level 5, the level will return to 1. After each change, the red light will flash to denote the new level.</p> <li data-bbox="662 1444 1460 1601"> <p>5</p>  <p>Once on the desired level wait 15 seconds and the sensor will exit the adjustment mode and can be used as normal.</p>
<p>The clamp doesn't tighten fully around the overflow pipe</p>	<p>You may need to add the collar part to the clamp.</p>	 <p>Slide the collar onto the overflow tube, this should allow you to secure the clamp around the wider overflow tube, such as the one found on TR9033. Ensure to install the collar in the correct orientation (with the rim facing downwards).</p>

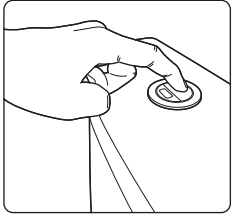
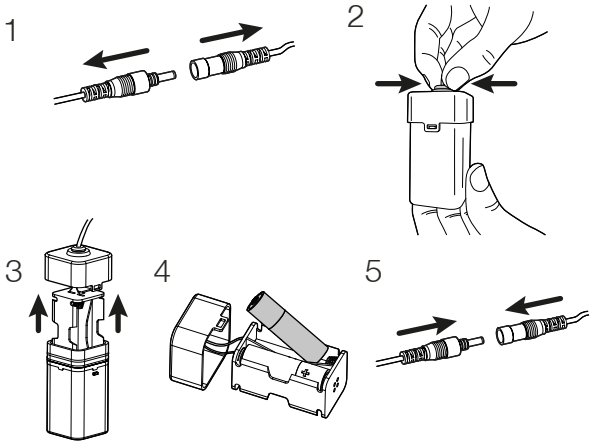
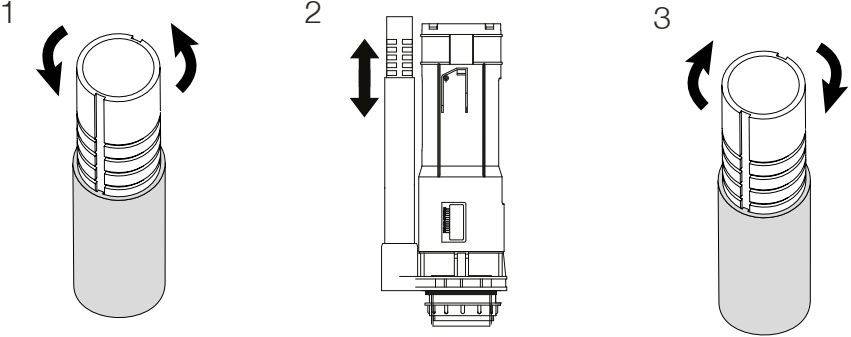
Problem	Potential cause	Suggested action
<p>When I activate my flush button it flashes and does not flush</p>	<p>The batteries have run empty. In the meantime please use the manual back up flush:</p> 	<p>Change the batteries as detailed below:</p>  <div data-bbox="1264 165 1549 595" style="border: 1px solid black; padding: 5px;"> <p>WARNINGS ⚠</p> <p>Non-alkaline batteries will provide a much shorter battery life.</p> <p>Do not mix batteries of different brands or mix old and new batteries.</p> <p>Once connected to the power, the flush system will act once to show it is working.</p> <p>If you are struggling to remove the battery box lid, squeeze the top washer to release the seal.</p> </div> <p>To access the battery box, first disconnect the quick connector and remove the battery box from the cistern. Next, remove the lid of the battery box making sure to squeeze the top washer to release the seal. You can now swap in new 4x1.5V AA batteries and reconnect the battery box back up to the rest of the flush unit.</p>
<p>The overflow pipe on my flush valve moves when I try to connect the clamp</p>	<p>The telescopic overflow pipe may be unlocked</p>	 <p>Fully unlock the overflow pipe by twisting the telescopic part anticlockwise. Adjust the height of the overflow pipe as required (please see diagram below for a guide of requirements). Once at the correct height, ensure one of the grooves in the telescopic overflow is aligned with the locking pin of the fixed section and twist clockwise to lock in position.</p> <div data-bbox="667 1395 1034 2033" style="border: 1px solid black; padding: 5px;"> <p>Flush valve and inlet valve arrangement requirements for type AG air gap.</p> <ol style="list-style-type: none"> 1) The height difference between the water level and the opening of the overflow pipe must be 25-32mm. 2) The height difference between the opening of the fill valve and the opening of the overflow pipe must be at least 20mm or 2x diameter of the fill valve opening. <p>Flush valve and inlet valve arrangement requirements for type AUK1 air gap.</p> <p>The height difference between the opening of the overflow pipe and the top surface of the WC pan must be a minimum of 300mm.</p> </div> 