

ASSEMBLY & INSTALLATION INSTRUCTIONS



Focal Point Fires Ltd
Christchurch, Dorset BH23 2BT
Tel: 01202 49933499330
Fax: 01202 499326
www.focalpointfires.co.uk
e : sales@focalpointfires.co.uk

Focal Point Fires Ltd
RBK House, Irishtown, Athlone,
Co. Westmeath, N37 XP52,
Ireland Tel: 01202 499330
Fax: 01202 499326
www.focalpointfires.co.uk
e: sales@focalpointfires.co.uk

MODELS COVERED BY THESE INSTRUCTIONS

F820680 FPFBQ553 MONTANA FIRE SURROUND WHITE

F820792 FPFBQ614 MONTANA FIRE SURROUND GREY

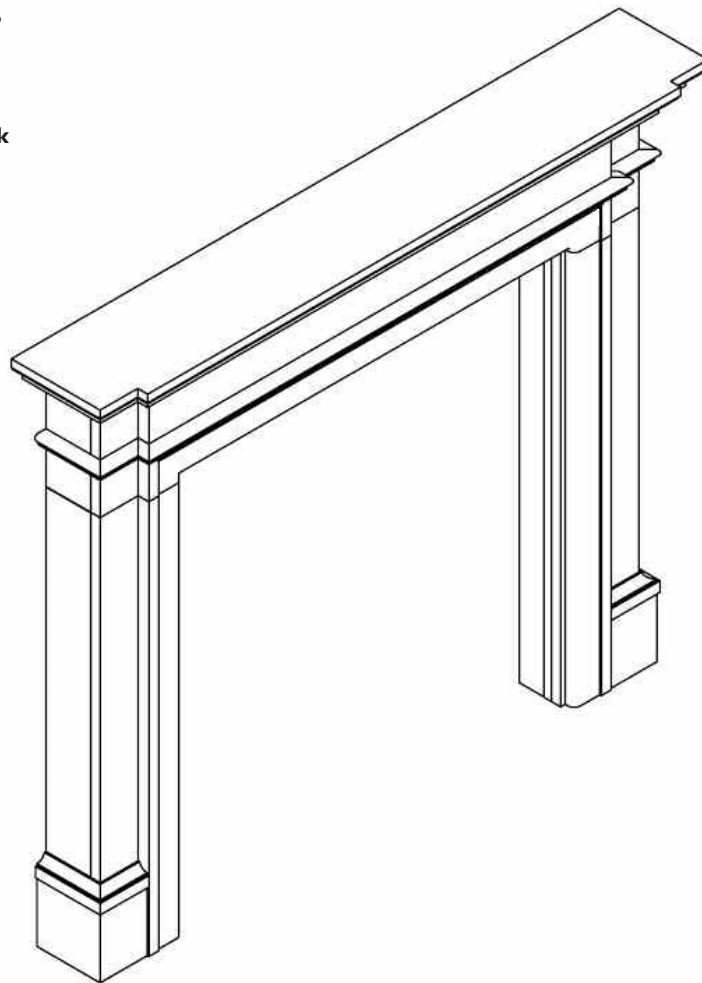

3 YEAR GUARANTEE

SUBJECT TO TERMS & CONDITIONS

For details please see: www.focalpointfires.co.uk or telephone
01202 588635 Option 4

Please note : Except where otherwise stated, all rights, including copyright in the text, images and layout of this booklet is owned by Focal Point Fires Ltd. You are not permitted to copy or adapt any of the content without the prior written permission of Focal Point Fires Ltd.

All instructions must be handed to the user for safekeeping.

Revision D - 11/21

© 2021 Focal Point Fires Ltd.

| Section | Contents | Page No. |
|---------|---|----------|
| 1.0 | Important notes | 2 |
| 2.0 | Tools required | 2 |
| 3.0 | Hardware & parts list | 2 |
| 4.0 | Assembly | 3 |
| 5.0 | Installation | 4 |
| 6.0 | Cleaning/ finishing | 5 |
| 7.0 | Guarantee - terms and conditions | 5 |

1.0 IMPORTANT NOTES

To ensure safe and stable installation:

1. The assembled Fire Surround must be fixed / secured to wall.
2. The wall must be sturdy and in good repair.
3. Some walls require alternative fixings (not included).
4. When drilling into the wall, check for hidden pipes and cables.
5. There are two options for construction of this surround.

A - with rebates - If you are installing this surround with a gas fire, or an electric fire where there is space in the wall to recess the fire, this means the laminate / marble is up against the wall.

B - with out rebates - If using this surround with an electric fire and a flat wall you will need to remove the rebates, instead use the spacer frame from the fire.

2.0 TOOLS REQUIRED









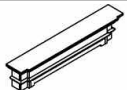

Cross head screwdriver PZ2 (3 inches in length or greater)

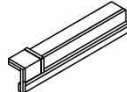
Drill, 6mm and a 2mm suitable drill bit

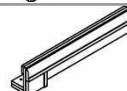
Pencil

Tape measure

3.0 HARDWARE & PARTS LIST

| CODE | NAME | FIGURE | QUANTITY | CODE | NAME | FIGURE | QUANTITY |
|------|--------------------------------|---|----------|------|---------------------------|---|----------|
| A | SCREWS (8x 25mm) |  | 16PCS | ① | TOP PANEL |  | 1PC |
| B | SCREWS (8x 40mm) |  | 9PCS | ② | LEFT LEG |  | 1PC |
| C | WOOD DOWELS (8x 30mm) |  | 16PCS | ③ | RIGHT LEG |  | 1PC |
| D | SCREWS (6x 20mm) |  | 4PCS | ④ | NARROW INSIDE PANEL |  | 3PCS |
| E | WALL SCREWS (6x 38mm) |  | 2PCS | ⑤ | CONNECT- ING BLOCK |  | 4PCS |
| F | WALL PLUGS (6x 25mm) |  | 2PCS | | | | |
| G | MIRROR PLATES (45x 43mm) |  | 2PC | | | | |

4.0 ASSEMBLY

STEP 1

| Fixings | Parts |
|-----------|-------|
| A x 8 PCS | 2 |
| | 3 |
| | 5 |

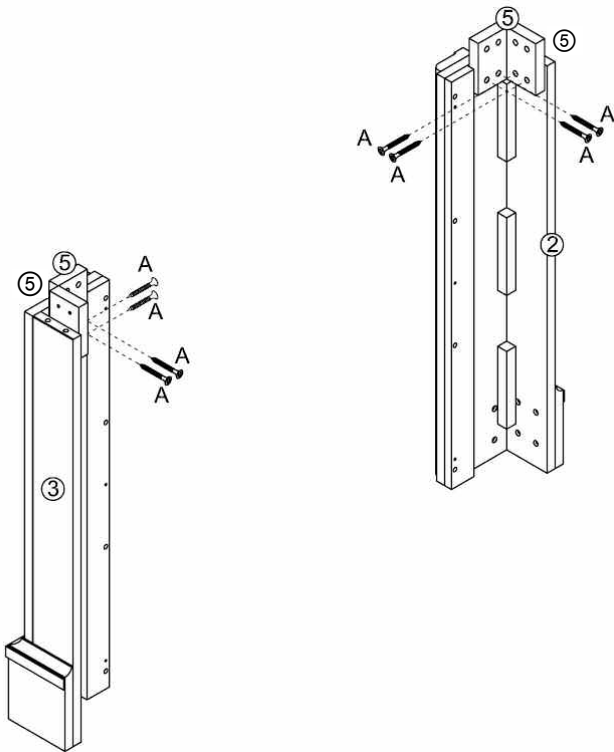

Screw the 4x connecting blocks (5) onto the rear of the left leg (2) and the right leg (3) with the 8x 25mm screws (A) provided.

STEP 2

| Fixings | Parts |
|-----------|-------|
| A x 8 PCS | 1 |
| C x 4 PCS | 2 |
| | 3 |
| | 5 |

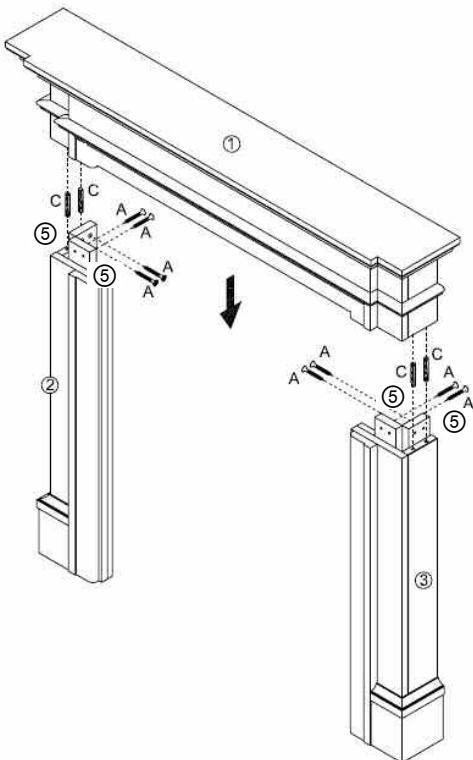

Next insert the 4x wood dowels (C) into the top of the left leg (2) and the right leg (3). Carefully place the top panel (1) on to the top of the left and right hand legs (2 and 3). Ensuring the top (1) lines up with the 4x connecting blocks (5) and the 4x wooden dowels (C). Once in place, screw the 8x 8x 25mm screws (A) through the connecting blocks (5) and into the top panel (1) securing it into position.

4.0 ASSEMBLY

GB IE

STEP 3

If using option A only. If rebates are not being used go to section 5.

| Fixings | Parts |
|------------|-------|
| B x 9 PCS | 1 |
| C x 12 PCS | 2 |
| | 3 |
| | 4 |
| | 5 |

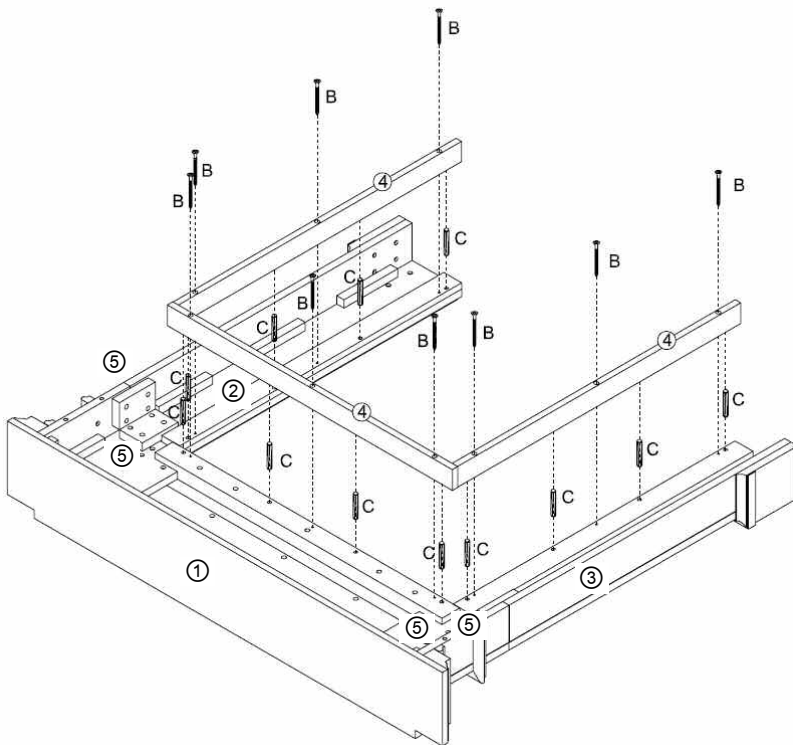

If a 75mm rebate (4) is required. CAREFULLY! lay the surround on a soft flat surface, taking extra care that you do not scratch the front of the surround. NEVER DRAG THE SURROUND! Insert the 12x wooden dowels (C) into the rear of the top panel (1), the left leg (2) and the right leg (3). With the rebates (4) in the correct orientation, place the 3x rebates (4) into position over the wooden dowels (C). Screw in the 9, 8x 40mm screws (B) through the rear of the rebates (4) connecting them to the surround.

5.0 INSTALLATION

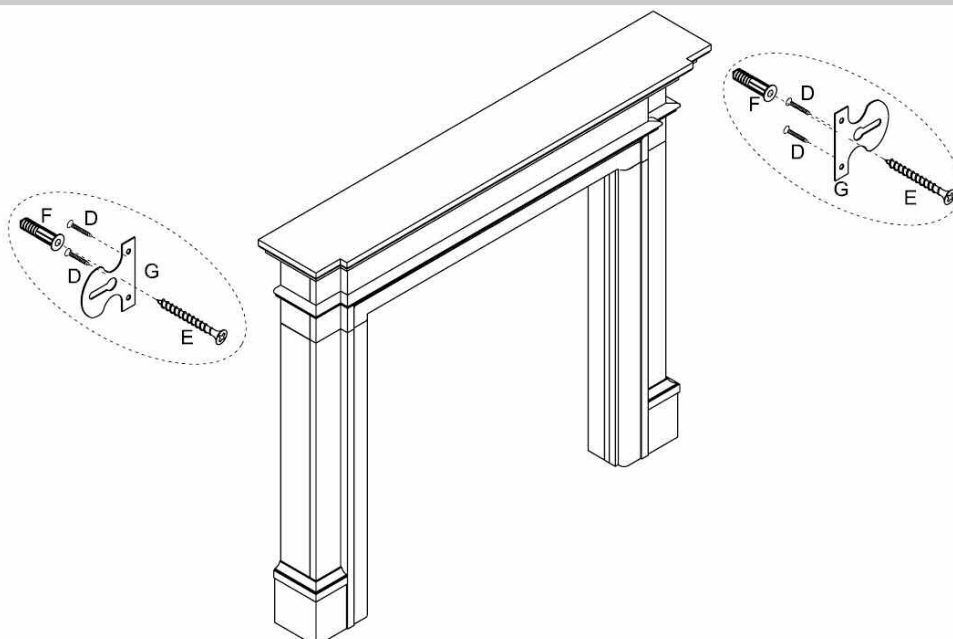

| Fixings | Parts |
|-----------|-------|
| D x 4 PCS | 1 |
| E x 2 PCS | 2 |
| F x 2 PCS | 3 |
| G x 2 PCS | 4 |

With a pencil mark out the desired height where you would like the mirror brackets (G) to be situated on the rear of the legs. To avoid splitting the leg, pre drill the bracket holes with a 2mm drill bit. Now attach the brackets to the legs using the screws (D). Once the brackets are in position, centre and level the hearth into its final fitting position. Position the surround on the hearth to correspond with the header/fireplace lintel, mark with a pencil on the wall where you wish to drill. Remove the surround and prepare the wall from the marked positions. If using the fixings supplied, drill a hole in the wall using a 6mm drill bit. If not, use a suitable drill bit for the wall plugs you are using. Insert the wall plugs (F) into position. Offering the surround back up into position against the wall, you are now able to secure the surround to the wall using the screws (E).

6.0 CLEANING/ FINISHING

GB IE

Before carrying out any of the following operations, ensure that the appliance is OFF and completely cold. Regularly clean around the appliance to ensure that dust, fluff, pet hair etc, are kept to a minimum. There are no other specific requirements for care, other than regular cleaning of the general appliance.

A wipe with a dry cloth is normally sufficient. **DO NOT** use abrasive cleaners as they can damage the finish. Test on a hidden part before cleaning. Clean only in the direction of the grain. Regularly check the surround is securely fixed in position.

7.0 GUARANTEE - TERMS AND CONDITIONS

The 3 year guarantee commences from the date of purchase, provided that the terms and conditions are adhered to:

Registration is not required.

1. For any claim to be made within the 3 years from date of purchase you will be required to provide and supply us with your proof of purchase.

Making a claim is easy.

If you wish to make a claim under our 3 year guarantee and all the terms and conditions for your product have been met then please submit the following information for the attention of the 3G Service Department to the address below. Alternatively, you can email or fax. Please note that this does not affect your statutory rights.

Focal Point Fires Ltd, 3G Service Department, Reid Street, Christchurch, Dorset, BH23 2BT.

Alternatively email: 3g@focalpointfires.co.uk or fax. 01202 499326.

Details required:

1. Name, full address including post code and contact telephone number.
2. Receipt of purchase or credit card statement.