

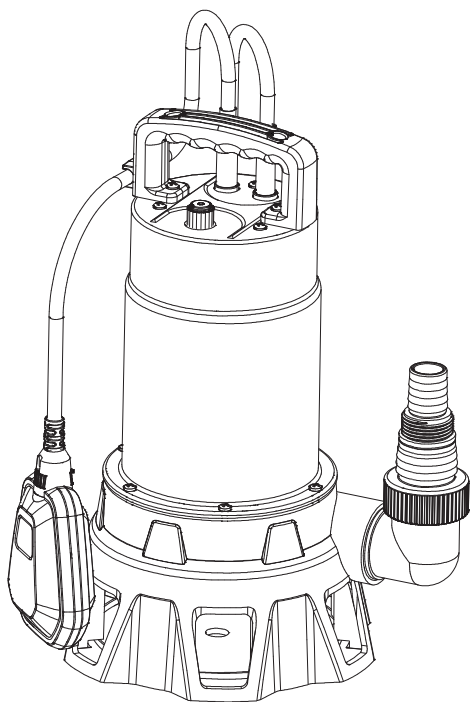

EN

TITAN

1000W 2" INOX dirty water pump



Original Instructions_MNL_TTB945PMP_GB_V2_230808

TTB945PMP

EAN: 5063022023315

CAUTION: Read the instructions before using the machine.



BX220IM

Let's get started...

These instructions are for your safety. Please read through them thoroughly before use and retain them for future reference.



Getting **started...** 02

Technical and legal information	03
Your product	07
Before you start	09



In more **detail...** 13

Product functions	14
Operation	16
Care and maintenance	17
Troubleshooting	21
Recycling and disposal	22
Guarantee	23
EC declaration of conformity	24

Safety information

General safety warnings

1. This appliance shall not be used by children. Cleaning and user maintenance shall not be carried out by children.
2. Always disconnect the appliance from the supply before assembling, disassembling or cleaning.
3. Appliances can be used by persons with reduced physical, sensory or mental capabilities or lack of experience and knowledge if they have been given supervision or instruction concerning use of the appliance in a safe way and if they understand the hazards involved.
4. Children shall not play with the appliance.
5. Pumps without indication that they are protected against the effect of freezing shall not be left outside during freezing weather conditions.
6. **Attention!** If the power cord is damaged, it must be replaced by the manufacturer, its service agent or similarly qualified persons in order to avoid a safety hazard.
7. Familiarise yourself with the operation, adjustments and functions. Follow the safety and operation instructions in order to avoid possible risks and hazards.
8. Contact a qualified person or your dealer if you have questions after reading the instruction manual.
9. Store the instruction manual so that it is accessible for all users. Also relay it when giving the product to others.
10. Do not attempt to modify the product in any way. Only use attachments and accessories recommended by the manufacturer.
11. Use the product only in accordance with this instruction manual. Misuse and incorrect handling will lead to hazards for people and property.

12. Do not use the product if damage is visible. Check the power cord, plug, attached hoses and casing before each use. Faulty products must be repaired or properly disposed of.
13. Disconnect the product from the power supply immediately if the cord or the product is damaged or if a breakdown occurs.
14. Have the product repaired only by a qualified specialist. Improper repairs can lead to electric shocks or other accidents.
15. Pull the plug rather than the power cord to disconnect the product from the power supply.
16. Do not let the power cord hang over edges, do not squeeze or bend it.
17. Use extensions cords that correspond with the technical requirements of this product if using an extension cord is unavoidable. When operating products outdoors, use an extension cord suitable for outdoor use.

Pump safety warnings

1. The appliance shall be installed in accordance with national wiring regulations.
2. The pump is to be supplied through a residual current device (RCD) having a rated residual operating current not exceeding 30 mA.
3. Prevent access of children with appropriate measures.
4. Do not use the pump when people are in the water.
5. Do not operate the pump without water.
6. Make sure that no marine animals (e.g. fish) are extracted by the pump.
7. Have in mind that pollution of the liquid could occur due to leakage of lubricants.
8. Protect the electrical connections and cords from heat, oil, sharp edges and moisture.
9. Protect the pump from frost and running dry.
10. Avoid circulation of aggressive fluids of abrasive materials.

11. Do not use the power cord to transport or secure the product. Fix a rope to the handle for submerging, lifting or securing.
12. Check and clean the outlet and the inlet of the pump when needed.
13. Do not pump liquids with sand or other abrasive substances. It causes increased wear and reduces the pumps output.
14. The product is designed for clear water with a diameter of suspended impurities not exceeded 35 mm.
15. The pump should be used for pumping water temperature below 35°C, do not use the product for other liquids (hydrocarbons, oils, corrosive liquids, flammable liquids...).
16. Never use the pump when there is the danger of frost occurring.
17. The product is not designed for continuous use. Please rest it for 10 minutes after each 1 hour of running.

Emergency

Familiarise yourself with the use of this product by means of this instruction manual. Memorise the safety directions and follow them to the letter. This will help to prevent risks and hazards.

1. **Always be alert when using this product, so that you can recognise and handle risks early.** *Fast intervention can prevent serious injury and damage to property.*
2. **Disconnect from the power supply if there are malfunctions.** *Have the product checked by a qualified professional and repaired, if necessary, before you operate it again.*

Safety information

Residual risks

Even if you are operating this product in accordance with all the safety requirements, potential risks of injury and damage remain. The following dangers can arise in connection with the structure and design of this product:

1. Health defects resulting from vibration emission if the product is being used over long periods of time or not adequately managed and properly maintained.
2. Injuries and damage to property due to broken attachments or the sudden impact of hidden objects during use.
3. Danger of injury and property damage caused by flying objects.
4. Risk of bursting.



WARNING! This product produces an electromagnetic field during operation! This field may under some circumstances interfere with active or passive medical implants! To reduce the risk of serious or fatal injury, we recommend persons with medical implants to consult their doctor and the medical implant manufacturer before operating this product!

Your product

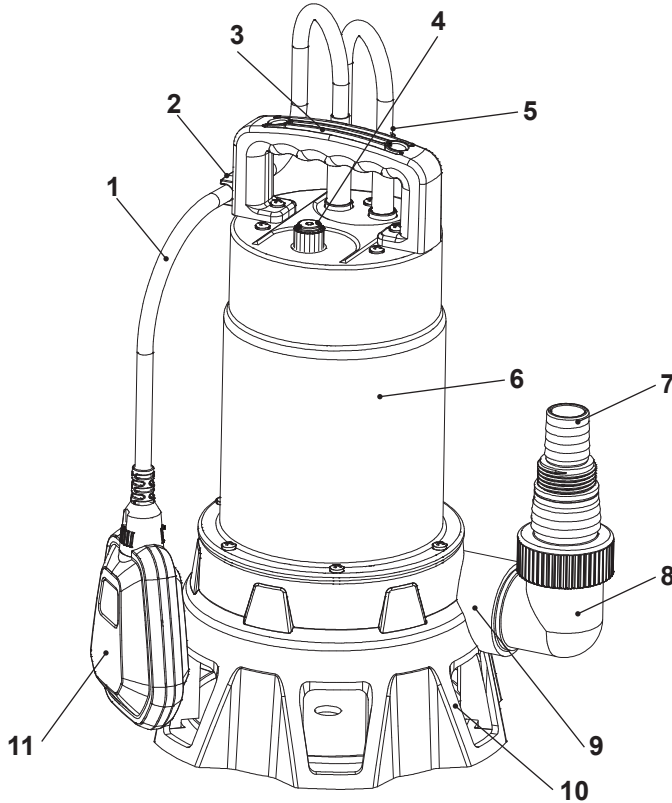



- | | |
|-------------------------|------------------|
| 1. Float switch cable | 8. Adaptor (2") |
| 2. Cable clip | 9. Outlet nozzle |
| 3. Carry handle | 10. Base |
| 4. Ventilation bore | a. Bottom plate* |
| 5. Power cord with plug | b. Screw (x3)* |
| 6. INOX Housing | c. Impeller* |
| 7. Hose connector | 11. Float switch |



NOTE: Parts marked with * are not shown in this overview. Please refer to the respective part in the instruction manual.



Getting started...

Technical specifications

> Rated voltage	:	220- 240 V~, 50 Hz
> Rated input power	:	1000 W
> Delivery rate (Q_{\max})	:	18500 l/h
> Maximum total head  (H_{\max})	:	max. 9 m
> Operating depth Σ  (m)	:	max. 7 m
> Water temperature	:	max. 35 °C
> Max. particle size	:	Ø 35 mm
> Protection class	:	
> Degree of protection	:	IPX8
> Net weight (assembled)	:	approx. 5.93 kg
> Dimensions	:	approx. 205 x 210 x 360 mm
> Outlet nozzle	:	Ø 25 mm (outer thread) for connector Ø 38 mm (outer thread) for adaptor
> Length of power cord	:	10 m

Symbols

On the product, the rating label and within these instructions you will find among others the following symbols and abbreviations. Familiarise yourself with them to reduce hazards like personal injuries and damage to property.

V ~	Volt, (alternating voltage)	Hz	Hertz
W	Watt	kg	Kilogram
ml	Millilitre	l	Litre
mm	Millimetre	m	Metre
l/h	Litre per hour	°C	Degree Celsius
	Lock / to tighten or secure.		Unlock / to loosen.



Read the instruction manual.



Note / Remark.



Caution / Warning.

xxWyy Manufacturing date code; year of manufacturing (20xx) and week of manufacturing (Wyy)

IPX8 The protection degree indicates that the product is suitable for continuous immersion in water.



Disconnect the product from the power supply before assembly, cleaning, adjustments, maintenance, storage and transportation.



Max. delivery rate



Max. particle size



Total head

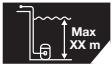

Max. operating depth



WEEE symbol. Waste electrical products should not be disposed of with household waste. Please recycle where facilities exist. Check with your Local Authority or local store for recycling advice.



The product complies with the applicable European directives and an evaluation method of conformity for these directives was done.

Rating label explanation

TTB945PMP

TT = TITAN

B = 220-240 V

945 = Random number generated

PMP = Pump

Unpacking

1. Unpack all parts and lay them on a flat, stable surface.
2. Remove all packing materials and shipping devices if applicable.
3. Make sure the delivery contents are complete and free of any damage. If you find that parts are missing or show damage do not use the product but contact your dealer. Using an incomplete or damaged product represents a hazard to people and property.
4. Ensure that you have all the accessories and tools needed for assembly and operation. This also includes suitable personal protective equipment.

Getting started...

Unpacking



WARNING! The product and the packaging are not children's toys! Children must not play with plastic bags, sheets and small parts! There is a danger of choking and suffocation!

You will need

(items not supplied)

suitable water hose or pipe including connectors /adaptors

rope

suitable gate valve

Fixing devices for installation e.g. hose clips

(items supplied)

Hose connector (7)

Adaptor (8)



NOTE: The accessories required depend on the intended application. Ask your dealer for advice.

Setup



WARNING! The product must be fully assembled before operation! Do not use a product that is only partly assembled or assembled with damaged parts!



Follow the assembly instructions step-by-step and use the pictures provided as a visual guide to easily assemble the product!

Do not connect the product to the power supply before it is completely assembled!

Accessories

1. Only use accessories that fulfil the requirements of this product. Pay special attention to the diameter of hoses / pipes, adaptors and connectors.
2. We recommend the use of quick-release fasteners on the appropriate place to quickly separate the product for cleaning and/or maintenance work (or for storage) from the hose / pipeline system.
3. Ensure that connectors and adaptors are fitted with gaskets rings and fasten them only hand tight.

Hose / pipe system

1. Install hoses / pipes in such a way that they do not exert any mechanical pressure on the product.
2. Secure hose / pipe in such a way as to prevent any oscillation, friction or weight impacting on the product.
3. Lay the hose / pipe in as short and straight as possible. Avoid an excessive number of bends.
4. Choose a reinforced delivery hose / pipe of the same or larger diameter as the outlet nozzle in order to reduce friction loss.

Installation

Follow below instructions depending on the required operation

1. Align and screw the hose connector (7) clockwise onto the adaptor (2") (8) if it is not already pre-assembled (Fig. 1).
2. Align and screw the adaptor (2") (8) clockwise to the outlet nozzle (9) (Fig. 2). Tighten it properly.

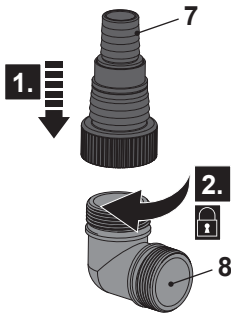

Fig. 1

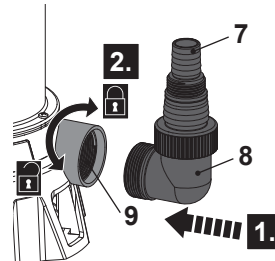

Fig. 2

3. Attach a suitable hose / pipe to the hose connector (7) and secure it with suitable fixing device, e.g. hose clip (Fig. 3).
4. Fasten a rope to the carry handle (3) and submerge the product carefully into the water reservoir (Fig. 4).



NOTE: Ensure the water reservoir has minimum dimensions of 40 x 40 x 50 cm, so that the float switch (11) can move freely.



NOTE: We recommend guiding the power cord by means of clamps (not supplied) alongside the fastening rope.

Setup

Getting started...

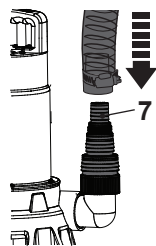

Fig. 3

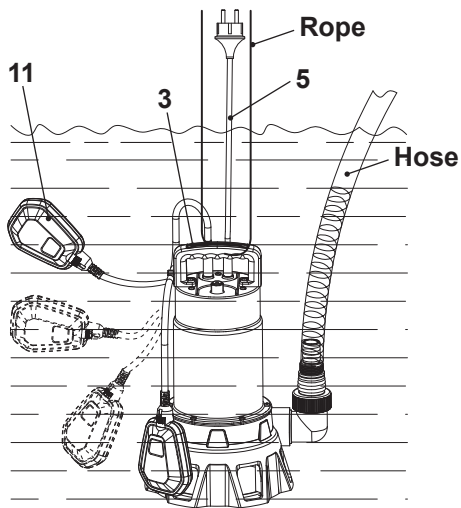

Fig. 4

Connection to power supply



NOTE: Ask a qualified electrician to ensure that the protective earth conductor and RCD correspond with the local safety regulations and work faultlessly before connecting the product to the power supply.

1. Make sure the float switch (11) is in its lower position.
2. Connect the plug (5) with a suitable socket.



WARNING! Check the voltage! The voltage must comply with the information on the rating label!

3. Your product is now ready to be used.



In more detail...

Product functions	14
Operation	16
Care and maintenance	17
Troubleshooting	21
Recycling and disposal	22
Guarantee	23
EC declaration of conformity	24

In more detail....

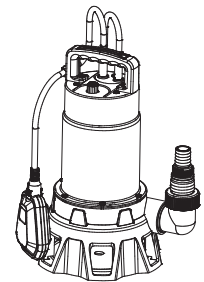

Intended use

This dirty water pump TTB945PMP is designated with a rated input power of 1000 Watts and is intended for the circulation of water with a maximum particle size of Ø 35 mm under a maximum temperature of 35 °C.

With suitable accessories the product can be used for draining rooms when flooding occurs and also for pumping over to or pumping out of water containers; to remove water from wells and shafts and for draining boats and yachts.

The product can be fully submerged (watertight encapsulation) and lowered to a water depth of 7 m.

This product works as a garden pond pump, but is not suitable for long term circulatory use (e.g. in a pond, swimming pool, aquarium). The product must be used for water with PH values between 6.5 and 8.5, and may not be used for other fluids, especially corrosive, flammable or explosive substances and other chemical products.

For safety reasons it is essential to read the entire instruction manual before first operation and to observe all the instructions therein.

This product is intended for private domestic use only, not for any commercial trade use. It must not be used for any purposes other than those described.

Float switch

This product works with automatic interval operation. The float switch (11) floats on the surface of the water or alternatively under water. The product switches on or off according to the position of the float switch (11). In this way, you can automatically control the water level e.g. in wells or containers.



NOTE: The float switch (11) contains a ball that activates a switch. The product works only if the float switch is above position A, position B corresponds to the switch off level for the pump (Fig. 5).

The product is started at a certain water level by the float switch (11) (switch on level) (Fig. 5, A). The product continues pumping until the water level is lowered to a particular height and then the float switch turns the product off (switch off level) (Fig. 5, B).

1. Adjust the height of the relative switch on and off levels within certain parameters by lengthening or shortening the free cable length of the float switch cable (1).
2. Fix the float switch cable (1) to the cable clip (2) afterwards (Fig. 6).



NOTE: Before first use you should briefly familiarize yourself with the automatic controls of the float switch (11). Move the float switch (11) up and down with your hand to simulate switching on and off. Alter the free cable length, until you have found a suitable range for your purpose. Examine how the free cable length influences the switch on and off level (and ultimately the water level).

- Always make sure that the float switch (11) is free and unblocked when in the water to prevent the pump dry running.

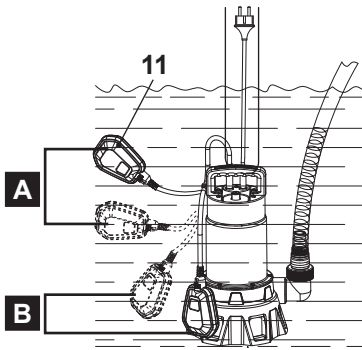

Fig. 5

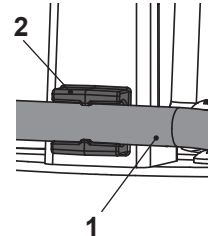

Fig. 6



NOTE: Make sure the base can freely draw water and is free of mud and debris, when lowering the pump to the bottom of the water source.

Thermal protection

The product is equipped with a thermal cut-out. In the event that the motor becomes overheated due to an over-load operation such as a clogged intake or low or no water, the thermal cut-out automatically switches the product off. After a cooling period the product automatically switches on again.

- Disconnect the product from the power supply in case the thermal protection is activated.
- Inspect the product for possible damage, wear or foreign objects e.g. that block the impeller.
- Eliminate the cause prior to re-starting the product (see “Troubleshooting”).



NOTE: Should the thermal protection continuously be activated even after following the steps under “Troubleshooting” do not continue to use the product. Have it checked and repaired by a qualified specialist.

Automatic air bleed valve

The automatic air bleed valve releases any air pockets in the pump body. During this process, air escapes through the ventilation bore (4) on the pump and air bubbles appear underwater. It may take several seconds when the pump is immersed for the first time.

In more detail...

General operation

1. Check the product, its power cord, float switch cable (1) and plug (5) as well as accessories for damage before each use. Do not use the product if it is damaged or shows wear.



NOTE: The product must be fully immersed into the water. Otherwise the product cannot prime and the maximum constant flow will not be achieved. The product could be damaged!

To have an automatic start the pump must be submerged in a water reservoir with a minimum water level of 70 cm. If the water level is any less, the pump may not suck properly and there is a risk of dry running.

2. Double check that the accessories are properly fixed.
3. Connect the plug (5) with a suitable socket to switch the product on.

Automatic operation

Connect the product to the power supply. The product is switched on automatically at a certain water level (switch on level) and switches off as soon as the water level drops down to a definite water height (switch off level).



NOTE: We recommend disconnecting the product from the power supply when you are not able to perform inspection over a longer period of time.

Manual operation



NOTE: This product can be used to suck up water with a lower height (minimum 20 to 30cm) but the float switch must be manually operated.

1. Put the pump into water.
2. Connect the product to the power supply.
3. Lift the float switch (11) to start the product.



NOTE: If the water is not pumped after 20 seconds of starting, lower the float switch and lift the pump. Wait until the pump is emptied. Immerse the whole pump in water. If the product does not pump after several attempts, the water level is too low to seal the system.

4. Lower the float switch (11) to stop the product.

After use

1. Disconnect the product from power supply and let it cool down.
2. Check, clean and store the product as described below.

The golden rules for care



WARNING! Always disconnect the product from the power supply and let it cool down before performing inspection, maintenance and cleaning work!



1. Keep the product clean. Remove debris from it after each use and before storage.
2. Regular and proper cleaning will help ensure safe use and prolong the life of the product.
3. Inspect the product before each use for worn and damaged parts. Do not operate it if you find broken and worn parts.



WARNING! Only perform repairs and maintenance work according to these instructions! All further works must be performed by a qualified specialist!

General Cleaning

1. Clean the product with a damp cloth and pH-neutral soap. Use a brush for areas that are hard to reach.
2. Remove stubborn dust with high pressure air (max. 3 bar).
3. Check for worn or damaged parts. Replace worn parts as necessary or contact an authorised service centre for repair before using the product again.

In more detail...

General Cleaning



NOTE: Do not use chemical, alkaline, abrasive or other aggressive detergents or disinfectants to clean this product as they might be harmful to its surfaces.

4. Check for worn or damaged parts. Replace worn parts as necessary or contact an authorised service centre for repair before using the product again.
5. Regularly check for obvious defects such as loose, dislodged or damaged hoses, loose fixings and worn or damaged components.

Impeller

If excessive deposits collect in the base, dismantle the base (10) of the product and clean the components (Fig. 7).

1. Loosen three screws (10b) anti-clockwise with a proper screwdriver and remove the screws (10b) together with the bottom plate (10a) from the base (10).
2. Clean the impeller (10c) with clean water.
3. Clean the base (10), the bottom plate (10a) and the outlet nozzle (9) if needed.
4. Assemble the product in a reverse order and secure the fixing.

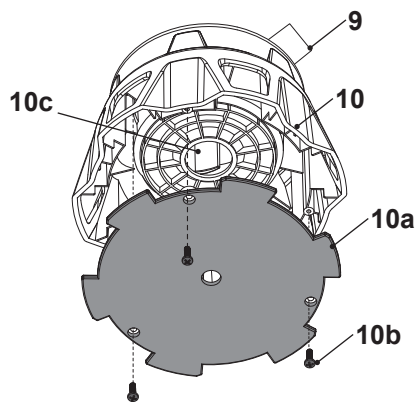

Fig. 7



NOTE: Take care of small parts that are removed during assembly or when making adjustments. Keep them secure to avoid loss.

Maintenance

Before and after each use, check the product and accessories for wear and damage. If required, exchange them for new ones as described in this instruction manual. Observe the technical requirements.

Power cord

If the supply cord is damaged, it must be replaced by the manufacturer, its service agent or similarly qualified persons in order to avoid a hazard.



WARNING!

Do not use the product with a defective or a loose power cord!

UK plug (only for UK market)

If you need to replace the fitted plug, then follow the instructions below.

IMPORTANT: The wires in the mains lead are coloured in accordance with the following code:

Blue – Neutral

Brown – Live

Green/Yellow - Earth

As the colours of the wire in the mains lead of this product may not correspond with the coloured marking identifying the terminals in your plug, proceed as follows. The wire, which is coloured blue, must be connected to the terminal, which is marked with N or coloured black. The wire, which is coloured brown, must be connected to the terminal, which is marked L or coloured red. The wire, which is colored green/yellow, must be connected to the terminal, which is mark E or .

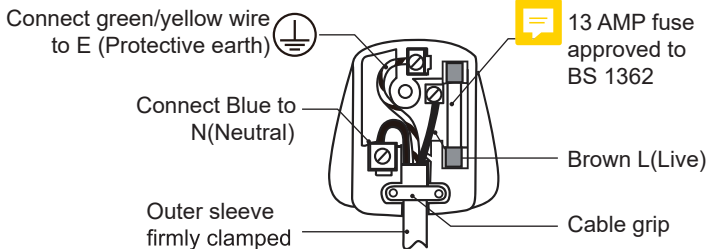

WARNING!

Never connect live or neutral wires to the earth terminal of the plug, which is marked with E.

Only fit an approved 13 Amp BS 1363 or BS 1363/A plug and the correctly rated fuse.

If in doubt, consult a qualified electrician.



NOTE: If a moulded plug is fitted and has to be removed take great care in disposing of the plug and severed cable, it must be destroyed to prevent engaging into a socket.

In more detail...

Repair

This product does not contain any parts that can be repaired by the consumer. Contact an authorised service centre or a similarly qualified person to have it checked and repaired.

Storage

1. Disconnect the product from the power supply.
2. Open all valves to release remaining water from the hose / pipe system.
3. Disconnect the product from the hose / pipe system.
4. Clean the product as described above.
5. Store the product and its accessories in a dark, dry, frost-free, well-ventilated place.
6. Always store the product in a place that is inaccessible to children. The ideal storage temperature is between 10°C and 30°C.
7. We recommend using the original package for storage or covering the product with a suitable cloth or enclosure to protect it against dust.

Transportation

1. Disconnect the product from the power supply.
2. Always carry the product by its carry handle (3).
3. Protect the product from any heavy impact or strong vibrations which may occur during transportation in vehicles.
4. Secure the product to prevent it from slipping or falling over.

Troubleshooting

Suspected malfunctions are often due to causes that the users can fix themselves. Therefore check the product using this section. In most cases the problem can be solved quickly.



WARNING! Only perform the steps described within these instructions! All further inspection, maintenance and repair work must be performed by an authorised service centre or a similarly qualified specialist if you cannot solve the problem yourself!

Problem	Possible cause	Solution
1. Product does not start	1.1. Power supply not connected 1.2. Float switch (11) does not switch on	1.1. Check power supply connection 1.2. Raise position of the float switch (11)
2. Insufficient flow / no flow	2.1. Reduced pumping capacity by dirty water 2.2. Hose / pipe is blocked 2.3. Hose / pipe system is damaged	2.1. Clean product or have worn-out parts replaced 2.2. Unblock hose / pipe 2.3. Replace it
3. Product does not switch off	3.1. Float switch (11) cannot move down	3.1. Ensure the float switch (11) can move freely
4. Product switches off after short operating period	4.1. Thermal cut-out stops product due to blockage 4.2. Thermal cut-out stops product due to high water temperature 4.3. Impeller (10c) is caught by foreign object	4.1. Remove blockage and clean the product 4.2. Make sure that the water temperature of max. 35°C is not exceeded 4.3. Remove blockage

In more detail...

Recycling and disposal



Waste electrical products should not be disposed of with household waste. Please recycle where facilities exist.

Check with your Local Authority or local store for recycling advice.

For further information visit www.recycle-more.co.uk.

The product comes in a package that protects it against damage during shipping. Keep the package until you are sure that all parts have been delivered and the product is working properly. Recycle the package afterwards.

Guarantee

We take special care to select high quality materials and use manufacturing techniques that allow us to create products incorporating design and durability. This product (**TITAN** 1000W INOX Dirty Water Pump) has a manufacturer's guarantee of 2 years against manufacturing defects, from the date of purchase (if bought in store) or date of delivery (if bought online), at no additional cost.

To make a claim under this guarantee, you must present your proof of purchase (such as a sales receipt, purchase invoice or other evidence admissible under applicable law), please keep your proof of purchase in a safe place. For this guarantee to apply, the product you purchased must be new, it will not apply to second hand or display products. Unless stated otherwise by applicable law, any replacement product issued under this guarantee will only be guaranteed until expiry of the original guarantee period.

This guarantee covers product failures and malfunctions provided the product was used for the purpose for which it is intended and subject to installation, cleaning, care and maintenance in accordance with the information contained in these terms and conditions, in the user manual and standard practice, provided that standard practice does not conflict with the user manual.

This guarantee does not cover defects and damage caused by normal wear and tear or damage that could be the result of improper use, faulty installation or assembly, neglect, accident, misuse, or modification of the product. Unless stated otherwise by applicable law, this guarantee will not cover, in any case, ancillary costs (shipping, movement, costs of uninstalling and reinstalling, labour etc), or direct and indirect damage.

This guarantee does not cover defects and damage caused by or resulting from:

- Normal wear and tear
- Overload, misuse or neglect
- Repairs attempted by anyone other than an authorised agent
- Cosmetic damage
- Damage caused by foreign objects, substances or accidents
- Accidental damage or modification
- Failure to follow manufacturer's guidelines
- Loss of use of the goods

If the product is defective, we will, within a reasonable time, repair or replace it.

Rights under this guarantee are enforceable in the country in which you purchased this product. Guarantee related queries should be addressed to the store you purchased this product from.

The guarantee is in addition to and does not affect your statutory rights.

In more detail...

EC declaration of conformity



(EN) EU DECLARATION OF CONFORMITY
 (FR) DÉCLARATION UE DE CONFORMITÉ
 (PL) DEKLARACJA ZGODNOŚCI UE
 (RO) DECLARAȚIA DE CONFORMITATE UE
 (ES) DECLARACIÓN UE DE CONFORMIDAD
 (PT) DECLARAÇÃO DE CONFORMIDADE UE

Product/ Produit/ Produkt/Produsul/Producto/Produto

- 1000W 2" INOX Dirty Water Pump/Pompe pour eau chargée inox 2" 1000 W/Po mpa 2" ze stali nierdzewnej do wody brudnej 1000 W/Pompă inox 2" pentru apă murdară 1000W/Bomba de agua sucia Inox 1000 W/Bomba de água suja em inox de 1000W/1000W 2" Inox Kirli Su Pompası
- TTB945PMP
- serial number range 000001 to 999999

Name and address of the manufacturer or his authorised representative:

Nom et adresse du fabricant ou de son mandataire:

Nazwa i adres producenta lub jego upoważnionego przedstawiciela:

Denumirea și adresa producătorului sau a reprezentantului său autorizat:

Nombre y dirección del fabricante o de su representante autorizado:

Nome e endereço do fabricante ou do respetivo mandatário:

Kingfisher International Products B.V.,
 Rapenburgerstraat 175E,
 1011 VM Amsterdam,
 The Netherlands

This declaration of conformity is issued under the sole responsibility of the manufacturer.

La présente déclaration de conformité est établie sous la seule responsabilité du fabricant.

Niniejsza deklaracja zgodności wydana zostaje na wyłączną odpowiedzialność producenta.

Prezenta declarație de conformitate este emisă pe răspunderea exclusivă a producătorului.

La presente declaración de conformidad se expide bajo la exclusiva responsabilidad del fabricante.

A presente declaração de conformidade é emitida sob a exclusiva responsabilidade do fabricante.

Object of the declaration/Objet de la déclaration/Przedmiot deklaracji/Obiectul declarației/Objeto de la declaración/Objeto da declaração

Product/Produit/Produkt/Produsul/Producto/Produto

Model/Modèle/Model/Modelul/Modelo/Modelo

EAN

1000W 2" INOX Dirty Water Pump
 Pompe pour eau chargée inox 2" 1000 W
 Pompa 2" ze stali nierdzewnej do wody
 brudnej 1000 W
 Pompă inox 2" pentru apă murdară
 1000W
 Bomba de agua sucia Inox 1000 W
 Bomba de água suja em inox de 1000W
 1000W 2" Inox Kirli Su Pompası

TTB945PMP

5063022023315

The object of the declaration described above is in conformity with the relevant Union harmonisation legislation:

L'objet de la déclaration décrit ci-dessus est conforme à la législation d'harmonisation de l'Union applicable:

Wymieniony powyżej przedmiot niniejszej deklaracji jest zgodny z odpowiednimi wymaganiami unijnego prawodawstwa harmonizacyjnego:

Obiectul declarației descris mai sus este în conformitate cu legislația relevantă de armonizare a Uniunii:

El objeto de la declaración descrita anteriormente es conforme con la legislación de armonización pertinente de la Unión:

O objeto da declaração acima descrito está em conformidade com a legislação de harmonização da União aplicável:

2006/42/EC as amended Machinery Directive

2014/30/EU as amended Directive Electromagnetic compatibility

2011/65/EU as amended Directive Restriction of the use of certain hazardous substances in electrical and electronic equipment

Directive 2006/42/CE relative aux machines

2014/30 / UE telle que modifiée Directive Compatibilité électromagnétique

Directive 2011/65/UE relative à la limitation de l'utilisation de certaines substances dangereuses dans les équipements électriques et électroniques

2006/42/WE w zmienionej dyrektywie maszynowej

2014/30 / UE ze zmianami Dyrektywa Kompatybilność elektromagnetyczna

2011/65 / UE ze zmianami Dyrektywa Ograniczenie stosowania niektórych niebezpiecznych substancji w sprzęcie elektrycznym i elektronicznym

2006/42/CE, astfel a fost modificată Directiva privind echipamentele

2014/30/UE, astfel a fost modificată Directiva privind compatibilitatea electromagnetica

2011/65/UE, astfel a fost modificată Directiva privind limitarea utilizării anumitor substanțe periculoase în echipamentele electrice și electronice

Directiva sobre maquinaria modificada 2006/42/CE

2014/30/UE modificada Directiva Compatibilidad electromagnética

2011/65/UE modificada Directiva Restricción del uso de determinadas sustancias peligrosas en equipos eléctricos y electrónicos

2006/42/CE como diretiva de máquinas alteradas

2014/30/UE como alteração da compatibilidade eletromagnética

2011/65/UE como restrição diretiva alterada da utilização de certas substâncias perigosas em equipamentos elétricos e eletrônicos

In more detail...

2011/65/UE como restrição diretiva alterada da utilização de certas substâncias perigosas em equipamentos elétricos e eletrônicos

References to the relevant harmonised standards used or references to the other technical specifications in relation to which conformity is declared:

Références des normes harmonisées pertinentes appliquées, y compris la date de celles-ci, ou des autres spécifications techniques, y compris la date de celles-ci, par rapport auxquelles la conformité est déclarée:

Odwolania do odnośnych norm zharmonizowanych, które zastosowano, wraz z datą normy, lub do innych specyfikacji technicznych, wraz z datą specyfikacji, w odniesieniu do których deklarowana jest zgodność:

Trimiteri la standardele armonizate relevante folosite, inclusiv data standardului, sau trimeri la celelalte specificații tehnice, inclusiv data specificațiilor, în legătură cu care se declară conformitatea:

Referencias a las normas armonizadas pertinentes utilizadas, incluidas las fechas de las normas, o referencias a las otras especificaciones técnicas, incluidas las fechas de las especificaciones, respecto a las cuales se declara la conformidad:

Referências às normas harmonizadas aplicáveis utilizadas, incluindo a data da norma, ou às outras especificações técnicas, incluindo a data da especificação, em relação às quais é declarada a conformidade:

EN 60335-1:2012+A11+A13+A14+A14+A2 +A15

EN IEC 60335-2-41:2021+A11

EN 62233:2008

EN ISO 12100: 2010

EN IEC 55014-1:2021

EN IEC 55014-2:2021

EN IEC 61000-3-2:2019+A1

EN 61000-3-3:2013+A1+A2



Authorised signatory and technical file holder/signataire et responsable de la documentation technique autorisé/ podmiot uprawniony do wystawienia i adres przechowywania dokumentacji technicznej/semnatar autorizat Ț i deȚ inȃtor al dosarului tehnic/firmante autorizado y titular del expediente tecnico/ signatário autorizado e detentor da ficha técnica

Kingfisher International Products B.V.,
Rapunburgerstraat 175E,
1011 VM Amsterdam,
The Netherlands

David Awe
Group Quality Director

: [30/10/2023]

In more detail...

EC declaration of conformity

**UK
CA**
(UK) DECLARATION OF CONFORMITY

Product

- 1000W 2" INOX dirty water pump
- TTB945PMP
- serial number range 000001 to 999999

Name and address of the manufacturer or his authorised representative:

Kingfisher International Products Limited
1 Paddington Square
London
W2 1GG
United Kingdom

This declaration of conformity is issued under the sole responsibility of the manufacturer.

Object of the declaration

Product	Model	EAN
1000W 2" INOX dirty water pump	TTB945PMP	5063022023315

The object of the declaration described above is in conformity with the relevant legislation:

Supply of Machinery (Safety) Regulations 2008 as amended
Electromagnetic Compatibility Regulations 2016 as amended
The Restriction of the use of Certain Hazardous Substances in Electrical and Electronic Equipment Regulations 2012 as amended

References to the relevant designated standards used or references to the other technical specifications in relation to which conformity is declared:

BS EN IEC 55014-1:2021
BS EN IEC 55014-2:2021
BS EN IEC 61000-3-2:2019+A1
BS EN 61000-3-3:2013+A2
BS EN 60335-1:2012+A15
BS EN IEC 60335-2-41:2021+A11
BS EN 62233:2008



Authorised signatory and technical file holder:

Kingfisher International Products Limited
1 Paddington Square
London
W2 1GG
United Kingdom

David Awe
Group Quality Director

On [30/10/2023]

In more detail...



Manufacturer • Fabricant • Producent • Producător • Fabricante:

UK manufacturer:

Kingfisher International Products Limited
1 Paddington Square, London, W2 1GG,
United Kingdom
www.kingfisher.com/products

EU manufacturer:

Kingfisher International Products B.V.
Rapenburgerstraat 175E
1011 VM Amsterdam
The Netherlands

www.diy.com | www.screwfix.com | www.screwfix.ie
To view instruction manuals online,
visit www.kingfisher.com/products