

---

# BRISTAN

---

## Installation Instructions and User Guide

Thermostatic Recessed  
Dual Control Shower Valve  
with Integral Diverter

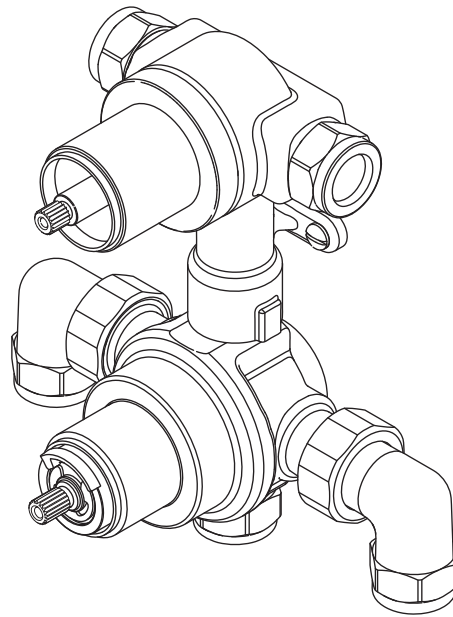

**Models covered: 241JX**

**Please keep this booklet for  
future reference.**

**Installer, when you have read  
these instructions please ensure  
you leave them with the user.**

# Contents

Thank you for choosing Bristan, the UK's leading showers and taps expert. We have designed this product with your enjoyment in mind. To ensure that it works to its full potential, it needs to be fitted correctly. These fitting instructions have been created to give you all of the information you need and, if you need any further help, please do not hesitate to give us a call on 0330 026 6273.

Important Safety Information .....	<b>3</b>
General Information .....	<b>4</b>
Product Features .....	<b>5</b>
Specifications .....	<b>6</b>
Pack Contents .....	<b>7</b>
Prior to Installation .....	<b>8</b>
Installation.....	<b>9-11</b>
Shower Valve .....	<b>9-10</b>
Wall Outlet .....	<b>11</b>
Operating the Shower .....	<b>12</b>
Maintenance.....	<b>13</b>
Adjusting the Temperature .....	<b>14</b>
Troubleshooting.....	<b>15-16</b>
Notes .....	<b>17</b>
Guarantee.....	<b>18-19</b>

# Important Safety Information

- Please read these instructions thoroughly and retain for future use.
- All products manufactured and supplied by Bristan are safe provided they are installed, used correctly and receive regular maintenance in accordance with these instructions.

**• If you are in any doubt about your ability to install this product safely you must employ the services of an experienced qualified plumber.**

- These fittings need to be installed in accordance with, and meet the requirements of the Water Supply (Water Fittings) Regulations 1999 and Scottish Byelaws 2004.
- Remove all packaging and check there are no missing or damaged parts.
- Before starting any installation please consider the following:
- Before drilling into walls, check that there are no hidden electrical wires, cables or water supply pipes. This can be checked with the aid of an electronic detector.
- If power tools are used do not forget to:
  - Wear eye protection
  - Unplug equipment after use

**•  Warning: Before installing the new shower valve it is essential that you thoroughly flush through the pipework in order to remove any remaining swarf, solder, etc. Failure to carry out this procedure could cause problems or damage to the workings of the shower valve.**

- Fitting isolation valves to the inlet feeds is required for ease of maintenance.
- Access must be made available to the shower valve/mixer body for maintenance /servicing purposes.

**•  Warning: Do not operate this product if you suspect it is frozen. Do not site the Mixing Valve where it might be subjected to freezing conditions.**

- These shower valves must not be modified in any way as this will invalidate the guarantee.

# General Information

This product has been tested to the Water Regulations Advisory Scheme (WRAS) and satisfies the requirements of the Water Supply (Water Fittings) Regulations 1999 and current bylaws.

For full Installation Requirements & Notes (IRN) please visit [www.wras.co.uk/directory](http://www.wras.co.uk/directory).

BS7600 recommends the temperature of stored water should never exceed 65°C. A stored water temperature of 60°C is considered sufficient to meet all normal requirements and will minimise the build up of lime scale in hard water areas.

If the shower valve is installed at low pressure (tank fed), then the minimum distance from the highest installed position of the shower head to the underside of the cold tank should be at least 1 metre to ensure adequate performance.

**Note:** Nominally equal (balanced) inlet supply pressures are recommended for optimum performance.

This shower valve should be installed in compliance with the Water Supply (Water Fittings) Regulations 1999 and the Scottish Bylaws 2004.

If in doubt, contact a registered plumber or your Local Water Authority or the Secretary of The Institute of Plumbing, address as follows:-

The Institute of Plumbing,  
64 Station Lane,  
Hornchurch,  
Essex,  
RM12 6NB  
Tel: 01708 472791

Recommended Usage			
Domestic	✓	Heavy Commercial	X
Light Commercial	✓	Health Care	X

# Product Features

## 1. Two outlet diverter

This outlet allows the user to divert the flow of water from one water outlet to another. E.g. Fixed rigid riser or an adjustable riser.

## 2. Temperature control

Adjustable temperature control.

Turn the handle clockwise for a cooler temperature.

Turn the handle anti-clockwise for a hotter temperature.

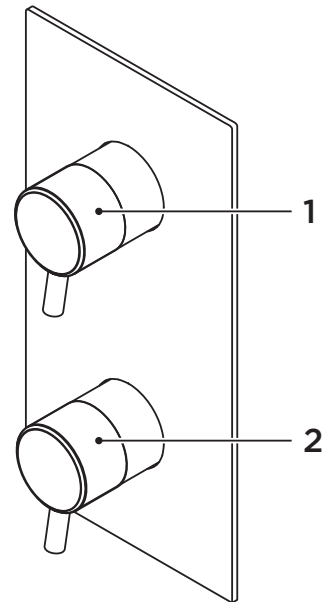

Example shown

# Specifications

**Inlet connections:** 15mm compression with 150mm between centres.

**Minimum working pressure:** 0.2 bar

**Note:** This shower has been designed to deliver a high flow of water on low pressure systems, however depending on the installation, type of system and shower accessories used, a higher pressure maybe required to optimise the showering experience.

**Maximum working pressure:** 5 bar

**Maximum static pressure:** 10.0 bar

Note: Static pressure is the build up of pressure when the valve is closed.

## Supply requirements:

Minimum cold water supply temperature: 5°C.

Maximum cold water supply temperature: 25°C.

Maximum hot water supply temperature: 80°C.

**Note:** The inlet hot water temperature must be at least 10°C above the required blend temperature (e.g. shower temperature 43°C: minimum hot water temperature 53°C).

## System requirements:

Gravity fed hot & cold (Equal pressures)

Gravity fed hot & mains cold (Differential pressure, maximum ration 5:1)

Unvented systems

Instantaneous water heater (Combination boiler)

Pumped system

**Note:** When using a pumped system we recommend that an essex flange is used.

**Important:** Minimum wall cavity depth: 35mm  
Min - Max Concealing plate thickness: 45-75mm

# Pack Contents

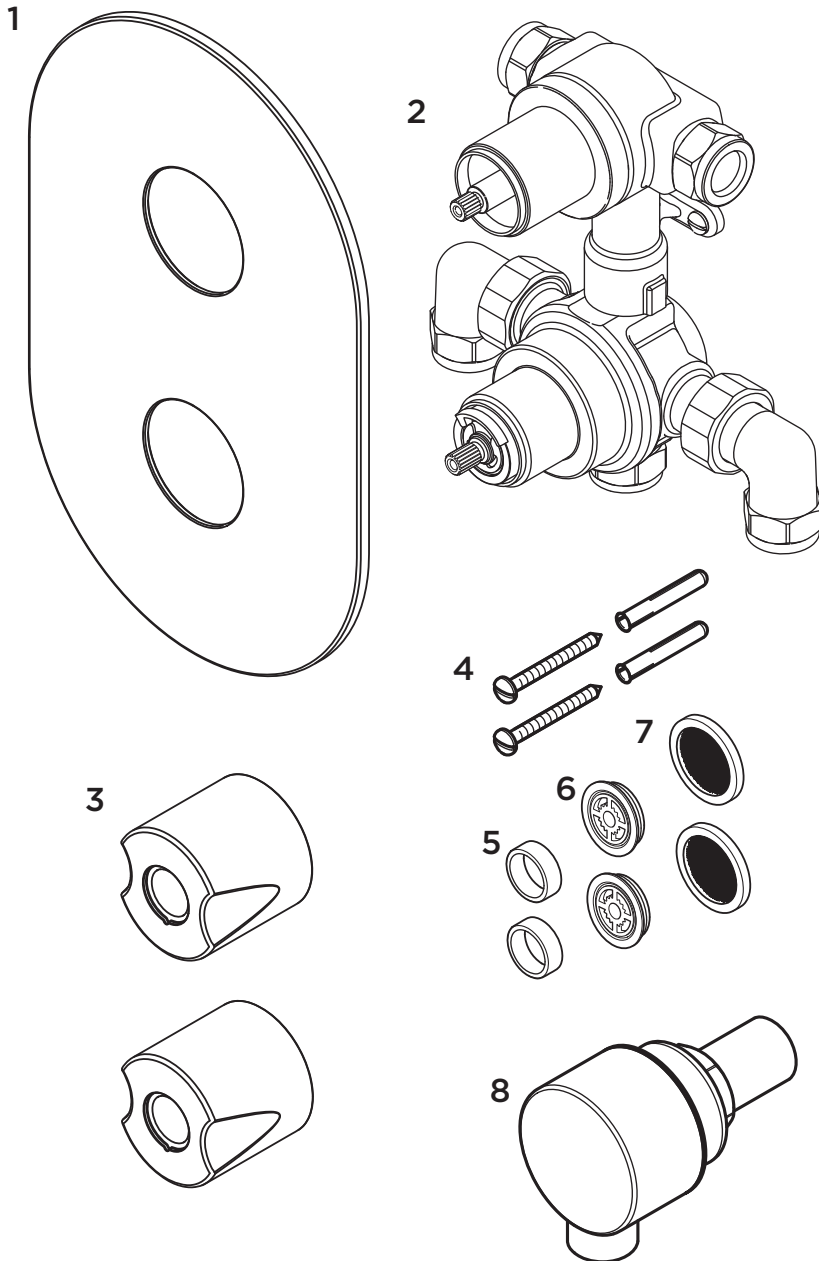

- 1. Concealing plate x1
- 2. Valve body x1
- 3. Handles x2
- 4. Valve body fixings x2/2
- 5. Inserts x2
- 6. Flow regulators x2
- 7. Filter washers x2
- 8. Wall outlet x1

# Prior to Installation

## Flow Regulators

This shower valve is supplied with a 5 and 7 litre per minute flow regulator loose in the box which must be fitted if the shower valve is installed in conjunction with an instantaneous water heater / combination boiler.

With both flow regulators fitted and by turning the water heater / combination boiler to its hottest setting, will ensure a sufficiently hot water supply to the shower valve during winter months (in the UK), when the mains cold water supply is at its coldest.

### To fit the flow regulators

Remove the inlet elbows ensuring the filter washer is also removed. carefully remove the plastic inserts from the valve inlets and push in the flow regulators. The 7 litre per minute flow regulator must be fitted to the cold inlet and the 5 litre per minute flow regulator must be fitted to the hot inlet.

Place the filter washers back into the elbow nuts and tighten the nuts fully onto the outlets.

In the event that this shower valve is not installed with an instantaneous water heater / combination boiler, the flow regulators do not need to be fitted.

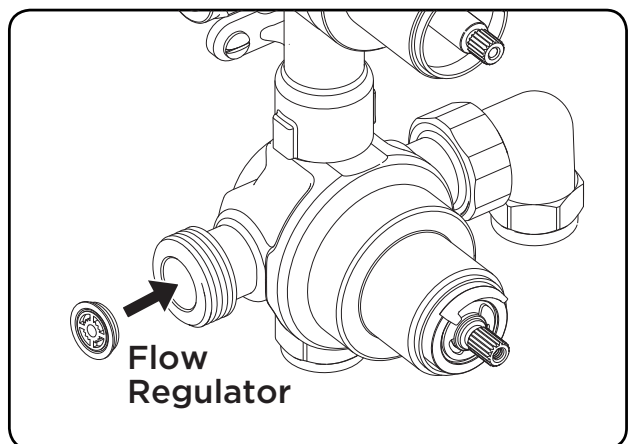
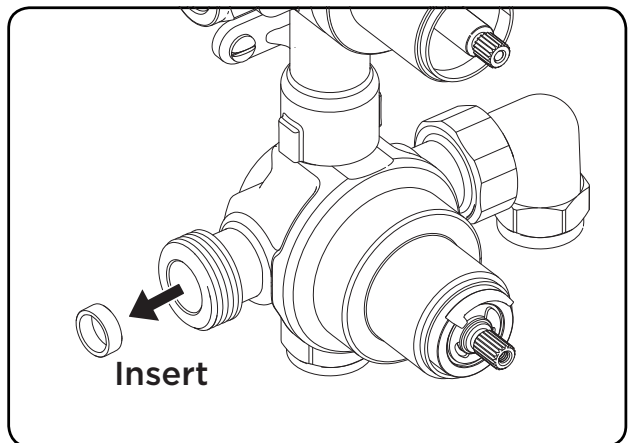
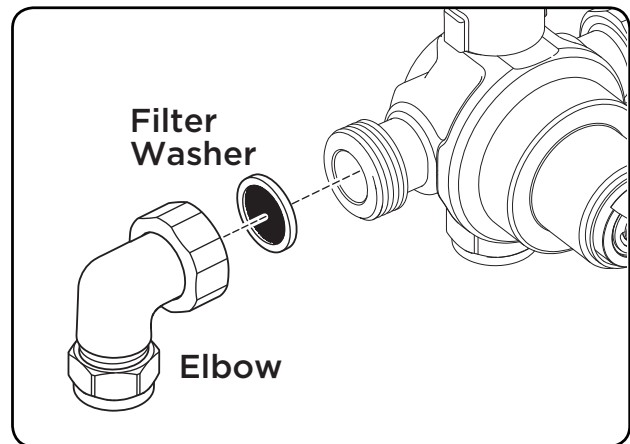



# Installation - Shower Valve

This shower valve is designed for installations where a recessed valve is already installed in the wall cavity and is to be replaced or for new installations.

## Before Installation

Flush through the pipework to ensure removal of any debris. Turn off the mains water supply and close any isolating valves.

1. Attach shower valve to wall  
Place the shower valve in the required position and mark the centres of the fixing holes onto the wall.

**Warning:** Please check for any hidden pipes and cables before drilling holes in the wall.

Drill suitable holes and insert the wall plugs. Securely attach the shower valve to the wall using the screws supplied.

2. Connect water supply pipes  
Insert 15mm hot and cold water supply pipes into the inlet connections and tighten nuts, ensuring the olives are fitted.

3. Plumb in outlets  
Insert 15mm pipework into the top and bottom outlets and plumb into the users chosen products. Ensure the olives are fitted when tightening the nuts.

**Important:** Water supplies to the mixer must be with hot on the left and cold on the right when viewed from the front.

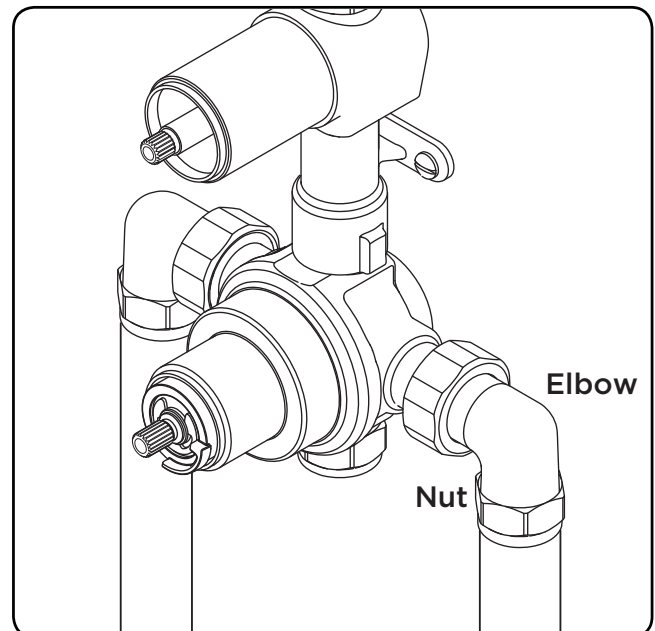
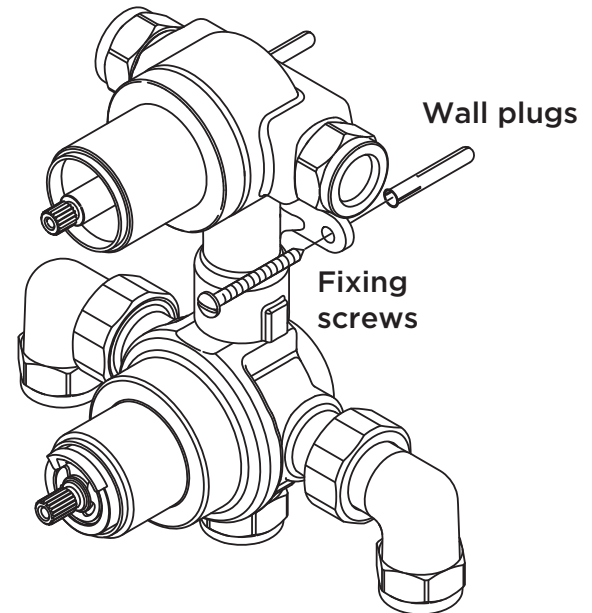

# Installation - Shower Valve

## 4. Fit concealing plate

**Note:** The concealing plate can be used as a template by drawing around the plate and measuring in by 10mm to give sufficient clearance.

Run a bead of waterproof silicon sealant around the inner edge of the concealing plate.

Slide the concealing plate onto the shower valve control handles and apply firm pressure to ensure to silicon sealant spreads.

## 5. Fit Handle

Push the spline adaptors (if required) onto the valve spindles.

Push the handles onto the spline adaptors and secure by tightening the grub screw and push-fit the cap into position.

**Important:** All maintenance and servicing of the shower valve, thermostatic cartridge and filters can be done from the front.

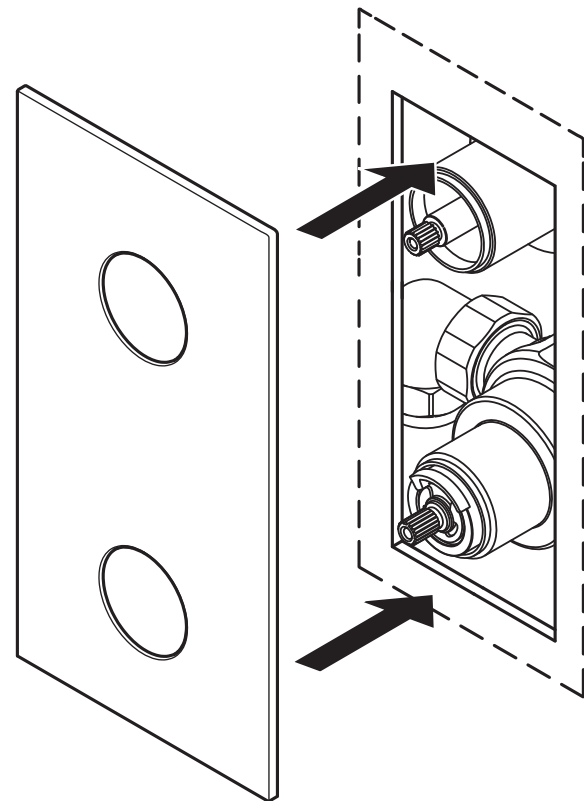

**Concealing plate**

# Installation - Wall Outlet

## Fitting the Wall Outlet

There are two methods of fixing the wall outlet depending on the type of wall:

### a: With rear access once wall finished

Fit the rubber washer to the back of the wall outlet, place the assembly through a 25-30mm hole in the wall and secure with the backnut ensuring the washer is fitted between the backnut and the wall.

Connect the wall outlet assembly to the shower valve outlet.

### b: Without rear access once wall finished

Fit a '1/2" female connection' (not supplied) within the wall cavity and plumb in from the shower valve. Screw the wall outlet into the '1/2" female connection' using a suitable thread sealant ensuring the rubber seal is fitted to the back of the wall outlet.

**Note:** The backnut and washer are not required.

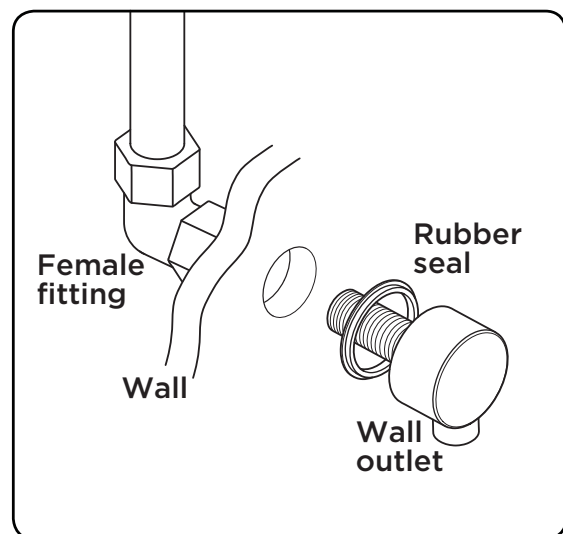
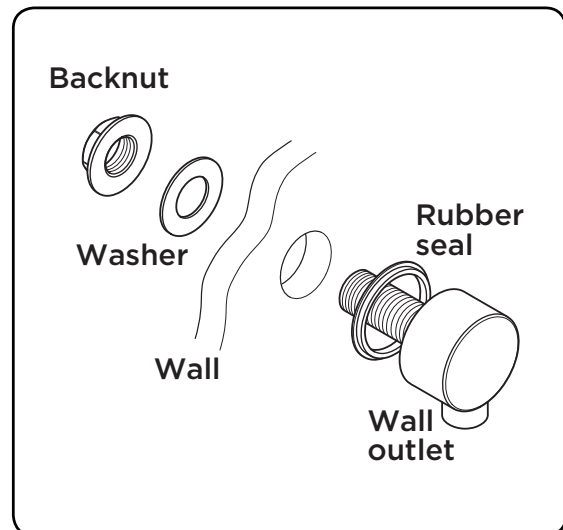

# Operating the Shower

## 1. Two outlet diverter

This outlet allows the user to divert the flow of water from one product to another.

Turn the handle one way or the other to turn the flow of water on to your chosen product.

To turn the flow of water off turn the handle back to the centre.

## 2. Temperature control

Adjustable temperature control.

Turn the handle clockwise for a cooler temperature.

Turn the handle anti-clockwise for a hotter temperature.

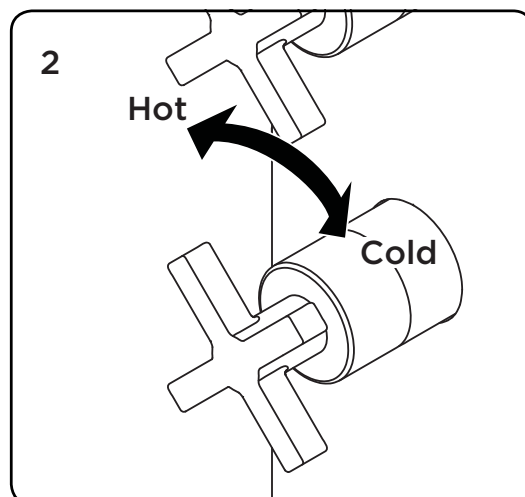
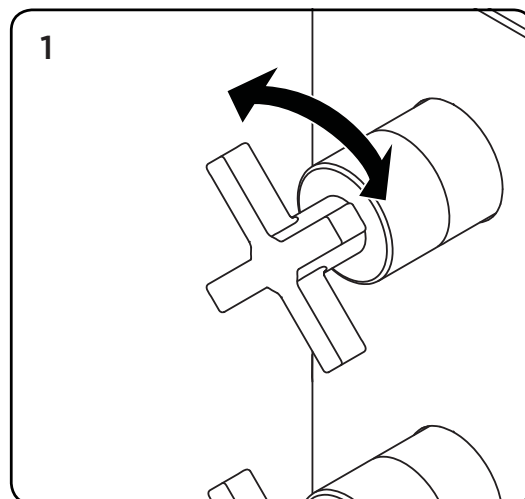

# Maintenance

## General Cleaning

Your fitting has a high quality finish and should be treated with care to preserve the visible surfaces. All surfaces will wear if not cleaned correctly, the only safe way to clean your product is to wipe with a soft damp cloth. Stains can be removed using washing up liquid. All bath cleaning powders and liquids will damage the surface of your fitting, even the non-scratch cleaners.

**Note:** Never use abrasive detergents or disinfectants or those containing alcohol, hydrochloric acid or phosphoric acid.

## Cartridge Maintenance

We advise that the shower valve is regularly serviced in hard water areas to maintain the flow of water.

Isolate both hot and cold water supplies to the shower valve by either:

- Turning the water supply off at the mains stopcock or
- Turning off the isolation valves to the shower valve.

1. Remove the temperature handle and plastic stop.

**⚠ Important:** Take note of the position of the plastic stop and handle - They must be refitted in the same position.

2. Unscrew the cartridge anti-clockwise and remove from the valve body.

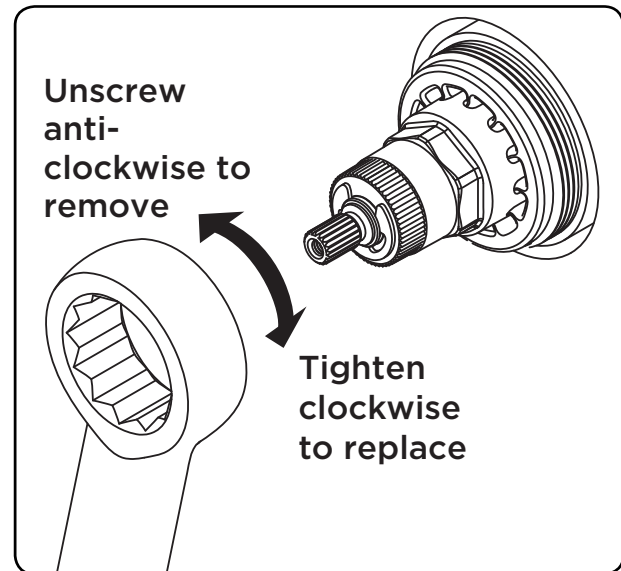

3. Remove the piston and thermostat assembly and place into a bowl. Soak in a suitable solution until fully de-scaled and rinse with clean water.

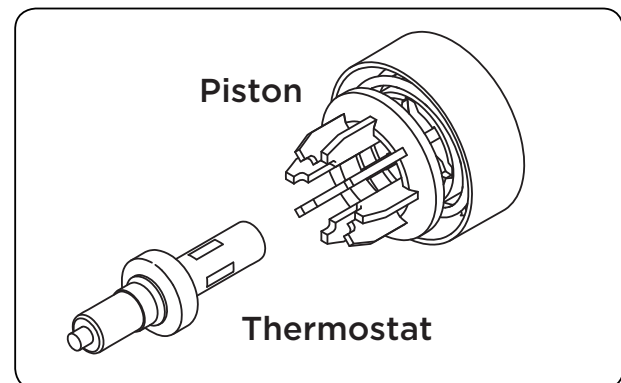

4. Grease the seals with a silicon grease supplied by Bristan and carefully refit.

5. Refit the temperature stop and handle. Reset the maximum temperature.

# Adjusting the Temperature

## Adjusting the Temperature

The shower valve has been factory set to 42°C with equal (balanced) hot and cold water supply pressures, with the hot water supply at 65°C.

If your operating conditions are different from those above, the outlet water temperature may differ from the factory setting.

If required the shower valve can be re-calibrated to suit your own temperature requirements.

Set the temperature control to the maximum setting and check the

temperature of the water with a thermometer. If the temperature is not correct, re-calibrate the shower valve:

1. Remove the temperature handle but do not remove the plastic temperature stop.
2. Turn the spline clockwise to decrease the temperature and anti-clockwise to increase the temperature. Check the temperature and adjust until you achieve the required temperature.
3. Replace the temperature handle ensuring it is fitted back into the maximum position.

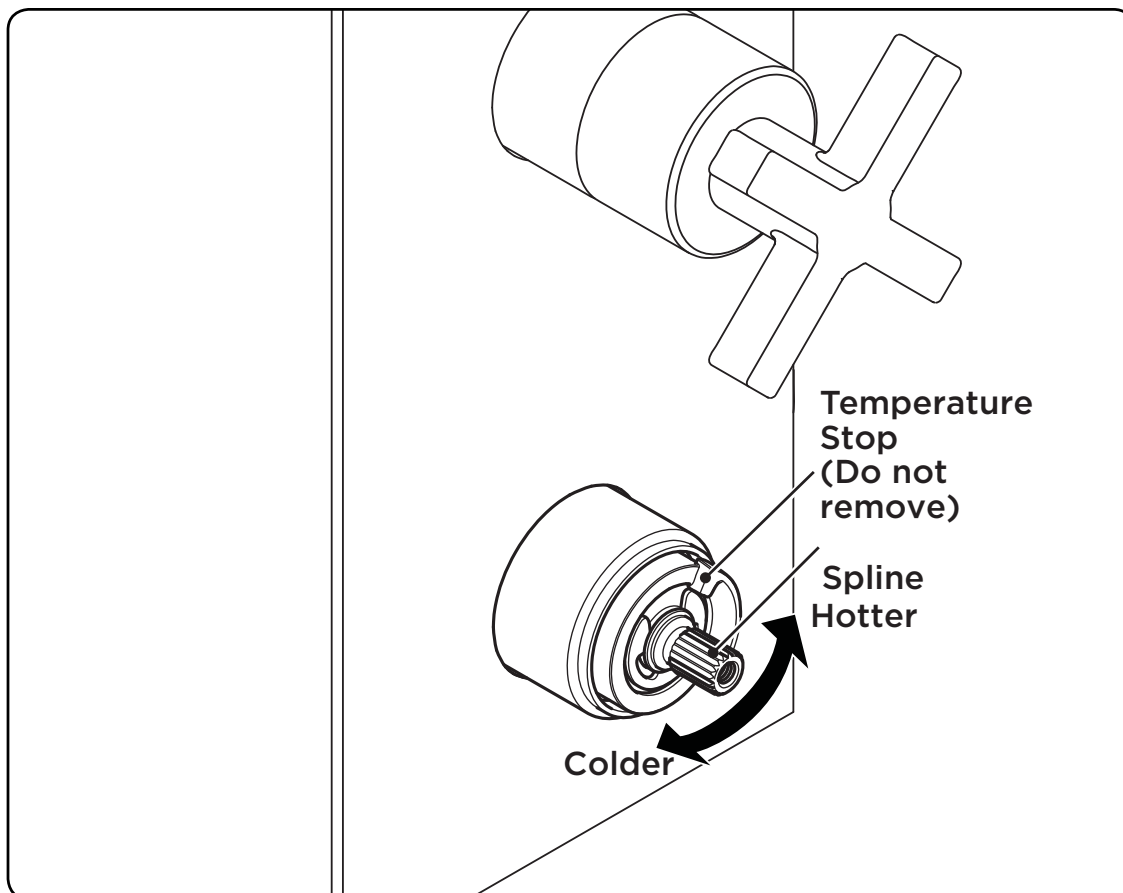

# Troubleshooting

Symptom	Cause	Remedy
No flow or low flow rate and/or varying temperatures.	Check showerhead, hose and filters for any blockage.	Clean as necessary, refer to Maintenance section (pg 13).
	Partially closed stop or service valve in water supply pipework to the shower valve.	Open stop or service valve.
	Instantaneous water heater cycles on and off as the flow rate or pressure is too low.	Increase water flow rate or pressure through system. Contact the boiler manufacturer.
	Head of water is below the minimum distance required.	Raise the cistern or fit a shower booster pump.
	Inlet filter is partially blocked.	Clean or replace, flush through pipework before refitting.
	Hot or cold water being drawn off elsewhere causing pressure changes or instantaneous boiler temperature changes.	Do not use other water outlets when using the shower.
	Make sure the maintained inlet pressures are nominally balanced and sufficient.	Refer to Specification (pg 6).
	Airlock or partial blockage of the pipework.	Flush through pipework to ensure removal of debris and any airlocks.
Only hot or cold water from the shower valve outlet.	No hot or cold water reaching the shower valve.	Check hot and cold feeds (the valve will shut down if either the hot or cold supply fails).
	Inlet water supplies are reversed (hot to cold supply).	Check the connections are the correct way round. Hot on the left and cold on the right when viewed from the front. Rework pipework as necessary.

# Troubleshooting

Symptom	Cause	Remedy
Only hot or cold water from the shower valve outlet.	Partially closed stop or service valve in water supply pipework to the shower valve.	Open stop or service valve.
	Inlet filter is partially blocked.	Clean or replace, flush through pipework before refitting.
Maximum water temperature too hot or cold.	Maximum water temperature set incorrectly.	Reset maximum water temperature. Refer to 'Maximum Temperature setting' in Maintenance section (pg 13) and 'Adjusting the Temperature' (pg 14)
Outlet water temperature too hot / cold.	Inlet filter is partially blocked.	Check inlet filters for any blockages and clean as necessary.
	Installation conditions outside operating parameters.	Refer to Specification (pg 6). Service shower valve as recommended. Refer to Maintenance section (pg 13). Refer to 'Adjusting the Temperature' section (pg 14).
Water temperature too cold - Maximum water temperature incorrectly set.	Hot water temperature is less than 10°C above the required blend temperature.	Adjust hot water temperature or wait for water to reheat if stored system is used.
	Instantaneous water heater not igniting because water flow rate is too low.	Increase water flow rate through the system. Check inlet filters and clean or replace. Refer to Maintenance section (pg 13). Contact the boiler manufacturer.



# Notes

Please use this space to add any notes you or your installer may have regarding the plumbing system / installation of this product.

# Guarantee

At Bristan, we want to make things as easy as possible for our customers. That's why we design products that are easy to fit and use, and that are quality tested to make sure they won't let you down. It's also why we offer solid guarantees on all products, effective from the date of purchase, to give you peace of mind.

Bristan's shower valves are covered by a **5 year guarantee. This also includes 1 year labour cover** \* (subject to registration) which means that, in the unlikely event that there is a problem in the first year after purchase, we'll send one of our expert engineers to fix it.

\*Labour is provided by an approved Bristan Care engineer or appointed representative. The guarantee only applies to products with a manufacturing fault. There will be a call out charge for any incidents where no fault has been found with the product, or if the issue is due to poor installation or maintenance.

## Guarantee Terms and Conditions

This guarantee is in addition to your statutory and other legal rights and is subject to the following conditions:

- The product was purchased within the United Kingdom or Republic of Ireland.
- The product is used in domestic applications only. For commercial or non-domestic applications such as leisure centres, sports clubs, hotels, premises operating as a business, the guarantee period is reduced to 1 year.
- The guarantee applies solely to the original purchaser with proof of purchase.
- The installation must allow ready access to all products for the purpose of inspection, maintenance or replacement.
- Repair under this guarantee does not extend the original expiry date. The guarantee on any replacement parts or product ends at the original expiry date.
- Any part found to be defective during the guarantee period will be replaced without charge, providing that the product has been installed in accordance with the product's fitting instructions and used as the manufacturer intended.

The guarantee does not cover damage or defects caused by:

- Incorrect installation
- Repair using non-Bristan parts
- Accidental or wilful misuse
- Corrosion caused by the use of inappropriate cleaning products
- System debris, including the build up of limescale (which can be controlled through regular servicing and maintenance)
- Compensation for loss of use of the product or consequential loss of any kind.

# Guarantee

## Need help?

If your product does not function correctly when you first use it, contact your plumber and make sure that it has been installed and commissioned in line with the Installation and User Guide supplied with the product.

If this doesn't solve the problem, then please visit [www.bristan.com/bristancare](http://www.bristan.com/bristancare) for some helpful hints and tips, or contact Bristan Customer Service on 0330 026 6273 where our expert team of advisors will be able to offer you, or your plumber, help and advice.

## Bristan Care Customer Support

Bristan customers also benefit from the support of Bristan Care, our comprehensive customer support package which offers:

## Technical support hotline

(Tel: 0330 026 6273) with access to fully trained advisers who can offer installation advice, talk you through quick maintenance checks, or recommend the best course of action to fix any problems with a product.

## Expert advice

Find easy to follow 'how to' video guides and technical FAQs online at [www.bristan.com](http://www.bristan.com). Our guides take you step-by-step through many product installations and you can find plenty of easy guides to quick product fixes and servicing.

## Spare parts

We hold thousands of spares and we keep them for discontinued products for over seven years. Spares can easily be ordered online at [www.bristan.com](http://www.bristan.com) and are dispatched the same day.

## Expert plumbing engineers

If we can't solve the problem over the phone or with a spare part, then we'll send out one of our Bristan Care engineers to take a look. Bristan Care engineers provide free support for products that are within guarantee, but are also available to service products that are out of guarantee for a small charge. For details, please call Bristan Care Customer Service on 0330 026 6273.

<b>Part Number: FI: 241JX SHCDIV</b>
--------------------------------------

<b>Issue: D1</b>
------------------

**TELEPHONE HELPLINE:** 0330 026 6273

Bristan Group Limited  
Birch Coppice Business Park  
Dordon  
Tamworth  
Staffordshire  
B78 1SG  
UK

A Masco Company

Website: [www.bristan.com](http://www.bristan.com)

Telephone: 0330 026 6273

Email: [enquire@bristan.com](mailto:enquire@bristan.com)