

Installation Instructions

CL4000



CODELOCKS

control + convenience

BOX CONTENTS

Check the contents of the box are correct according to the lock model:

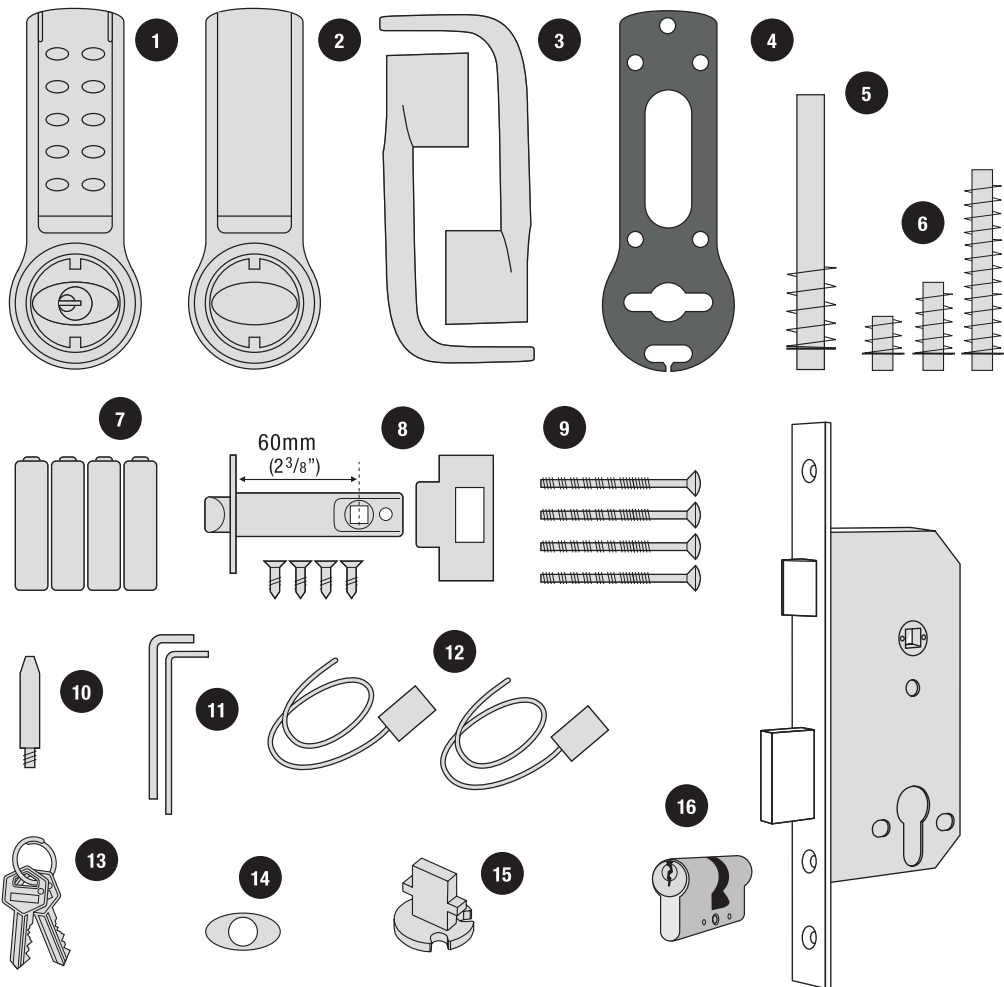

Box Contents	CL4010	CL4020
1 Front Plate	✓	✓
2 Back Plate	✓	✓
3 Lever Handles	✓	✓
4 Gaskets (x2)	✓	✓
5 Sprung Spindle	✓	-
6 Sprung Spindles (x3) - 15, 26, 60mm ($\frac{9}{16}$ ", 1", $2\frac{3}{8}$ ")	-	✓
7 1.5v AA Batteries (x4)	✓	✓
8 Mortise Latch, Strike and 4 screws	✓	-
9 Fixing Bolts (incl. spare)	x3	x3
10 Latch Support Post	✓	-
11 Allen Keys	✓	✓
12 Cable Connections for REM1 and REM2	✓	✓
13 Front Plate Cylinder Keys	✓	✓
14 Front Plate Cylinder Cover	✓	✓
15 Classroom Function Tailpiece	✓	✓
16 Mortise Lock & Cylinder for CL4020	-	✓



Tools Required

- Power Drill
- Drill bits CL4010:
10mm ($\frac{3}{8}$ ") & 25mm (1")
- Drill bits CL4020:
10mm ($\frac{3}{8}$ "), 12mm ($\frac{1}{2}$ "), 16mm ($\frac{5}{8}$ ") & 20mm ($\frac{3}{4}$ ")
- Hammer / Mallet
- Philips screwdriver
- Chisel 25mm (1")
- Stanley knife
- Adhesive tape, pencil, bradawl, tape measure
- Pliers and hacksaw for cutting bolts

DIMENSIONS

**CL4010
Mortise Latch**

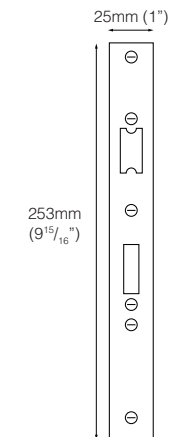
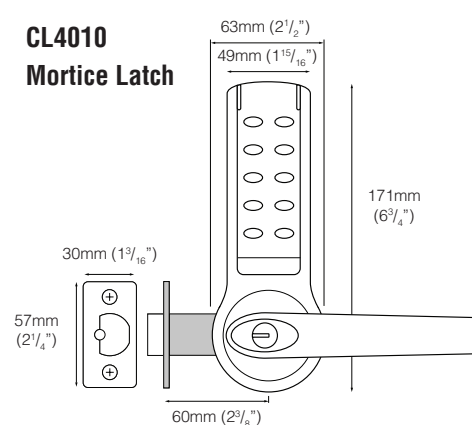

**CL4020
Mortise Lock**

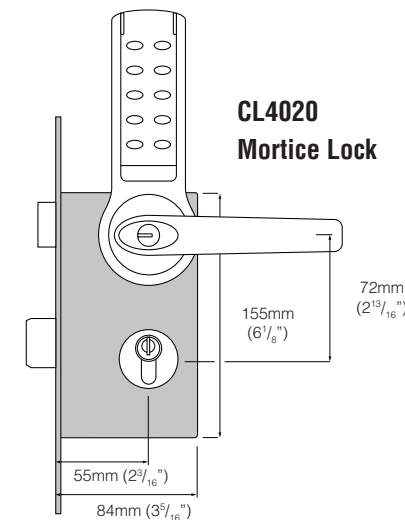

You should familiarise yourself with the operation of the lock and check that all parts work properly.

Remove the battery cover from the back plate and install the 4 x AA cells supplied.

Connect the cables from the front plate and back plate. A BEEP should be heard when you do this. If no BEEP is heard then check that the batteries are correctly installed.

Place the long spindle in the front plate socket and using finger grip only, test that the spindle is easily moved 80° in both directions. Leave socket in the centred position.

Enter the factory Master Code: Badge Bar **CODELOCKS.COM** 1234.
N.B. When the Master Code is entered 3 times consecutively without performing a programming function, a penalty time of 10 seconds is activated.

The Blue light should flash and the spindle should not turn as before. After 5 seconds the red light should flash and the spindle should turn easily again. This confirms that the clutch engaged correctly when the code was entered.

Disconnect the cables.

Before the next check, you must install the cylinder cover and lever as per step 13.

Turn the key in the front plate cylinder 90° clockwise and confirm that the spindle will not turn with the key in this position. Remove the key and confirm that the spindle again turns easily. This confirms that the key bypass function operates correctly.

For the CL4020 see page 10 to check the operation of the mortice lock.

REMOTE RELEASE OPTION

Cables are provided for the **REM 1** and **REM 2** terminals on the circuit board. (Fig 1 below).

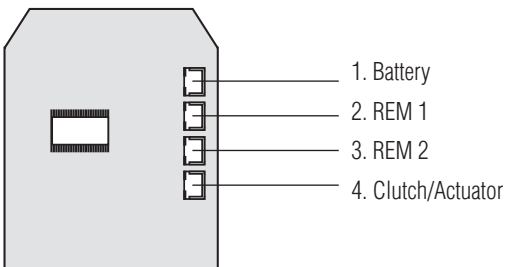

REM 1 is for connection to a reception desk push button or a door intercom system. Pressing the button will cause the blue light to flash on the lock and release the lock for the pre-set time.

REM 2 is for connection to the building alarm system to release a door in an emergency. This allows rooms, wards, offices to be easily checked to ensure that no person is trapped or overlooked during an emergency evacuation. When activated **REM 2** will maintain the unlocked condition for 30 minutes, the red LED will flash and BEEP during this time.

The lock will automatically lock again after 30 minutes. If necessary Program 11 can be used to re-lock before the end of the 30 minutes.

REM 1 and **REM 2** do not require additional power. They are normally open contacts requiring a momentary or maintained signal to close.

Take time to be precise and finish the job quicker.

Installation holes must be drilled in exactly the correct positions and precisely at right angles to the door surface. Lock components must be vertically and horizontally accurate in relation to each other and to the door.

WEDGE THE DOOR FIRMLY TO PREVENT MOVEMENT WHILST DRILLING AND CHISELLING.

- 1 Lightly mark a height line on the edge and both faces of the door, to indicate the top of the lock when fitted. Crease the template along one of the dotted lines (60mm (2³/₈" or 70mm (2³/₄" latch) and tape it to the door with the top in line with the height line. Mark the holes to be drilled. Mark the centre line of latch on to the door edge. Apply the template to the other side of the door precisely against the height line and the centre line of latch mark. Mark the holes to be drilled again. (See diagram A).
- 2 Keeping the drill level and straight, drill a 25mm (1") hole in the centre of the door edge to accept the latch.
- 3 Keeping the drill level and straight, drill the holes in the door face. Drill from both sides of the door to increase accuracy and to avoid damage to the other side when a drill goes right through.
- 4 Put the latch into the hole and, holding it square to the door edge, draw around the faceplate. Starting with the top and bottom cuts, chisel a rebate to allow the latch face to flush with the door edge. (See diagram B).
- 5 Fix the latch with the wood screws, with the bevel towards the doorframe.
- 6 Fit the latch support post on the inside of the front plate, in hole A for a right hand hung door and hole B for a left hand hung door. (See diagram C).

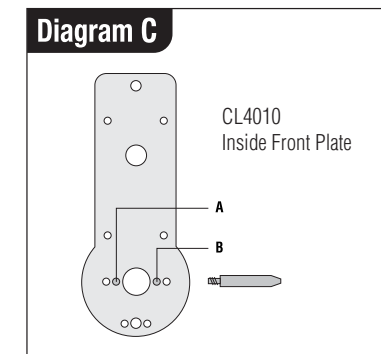
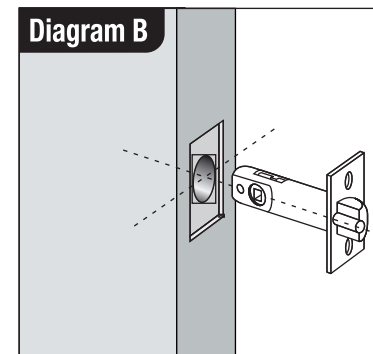
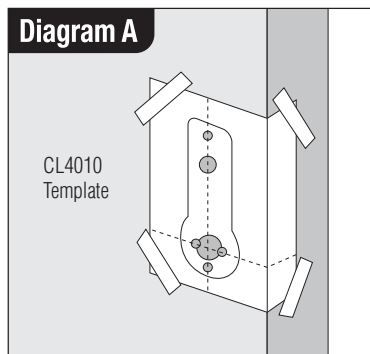

CL4010 INSTALLATION INSTRUCTIONS

7 Fit the self-adhesive gaskets to the front and back plates. The gaskets provide friction against the door so that it is not necessary to over-tighten the fixing bolts to provide stability.

8 Cut the fixing bolts to correct length. Measured from beneath the bolt head, the length should be the door thickness, plus approximately 15mm ($\frac{9}{16}$ ") to the nearest cutting point of the bolt.

N.B. Always cut the bolts at one of the cutting points so as not to damage a thread. Use the cutting edges of pliers to crimp strongly several times around the selected cutting point. The surplus end should break off quite easily.

9 Put the spindle into the latch with the spring on the front plate side of the door.

10 Remove the battery cover from the back plate, and remove the battery pack. Apply the front plate over the spindle, passing the latch support post through the latch and the cable through the door. With both parts of the back plate together place them over the spindle, pull the cable through, and screw the fixing bolts through to the front plate.

11 Using the inside handle boss check that the spindle moves freely, and that the latch retracts and projects smoothly. If it is tight, loosen the fixing bolts slightly and adjust the position of the back plate until the spindle will turn freely. Tighten the fixing bolts. Test the spindle again. Do not over-tighten the bolts as this may cause the door to distort and affect the lock function.

12 Connect the cables, storing any excess cable within the door. Then install the battery pack.

13 Fit the cylinder cover and codeside handle to the front plate.

14 Fit the inside handle to the back plate.

15 The inside handle will now retract the latchbolt. The outside handle will turn freely without retracting the latch. Enter the factory Master Code: Badge Bar CODELOCKS.COM 1234. The blue light will flash and the codeside handle will now retract the latch.

16 FITTING THE STRIKE PLATE.

Position the strike plate on the doorframe so that the aperture lines up with the flat of the latchbolt, and NOT the plunger. Mark the positions of the fixing screws and draw around the aperture of the strike plate. Chisel out the aperture to 15mm ($\frac{9}{16}$ ") deep to receive the latchbolt. Fix the strike plate to the surface of the frame using only the top fixing screw. Gently close the door and check that the latchbolt enters the aperture easily, and is held without too much 'play'. When satisfied, draw around the outline of the strike plate, remove it and cut a rebate to enable the strikeplate to lie flush with the surface. Re-fix the strike plate using both screws.

N.B. The plunger beside the latchbolt deadlocks it to protect against manipulation or 'shimming'. The strike plate must be accurately installed so that the plunger CANNOT enter the aperture when the door is closed, even when it is slammed shut.

CL4020 INSTALLATION INSTRUCTIONS

IMPORTANT The Anti-Panic Mortice Lock has features which are not found in most other locks and so it is recommended that you familiarise yourself with them.

The hand of the latchbolt is changed by removing the three screws holding the faceplate and reversing the latchbolt.

Insert the cylinder centrally in the lockcase and fix in position with the long bolt through the faceplate.

Using the key it should be possible to double-throw the deadbolt, retract the deadbolt, and retract the latchbolt.

The latchbolt follower is in 2 parts, with 2 set screws visible in each part. Determine which side of the lock will be the codeside and remove the set screws from that side. DO NOT remove the set screws from both sides. The codeside handle will now retract the latchbolt but NOT the deadbolt.

The inside handle will now simultaneously retract the latchbolt AND the deadbolt if it is thrown.

This safety feature ensures that it is not possible to accidentally lock someone in a room by throwing the deadbolt from outside.

Throwing the deadbolt will deny access to code users when appropriate.

All door locks should be installed with a degree of precision to ensure that all components are horizontally and vertically accurate in relation to each other, and in relation to the door.

Do not install the lock where it will involve cutting into a joint between the door stile and a mid-rail.

Anti-Panic Mortice Lock

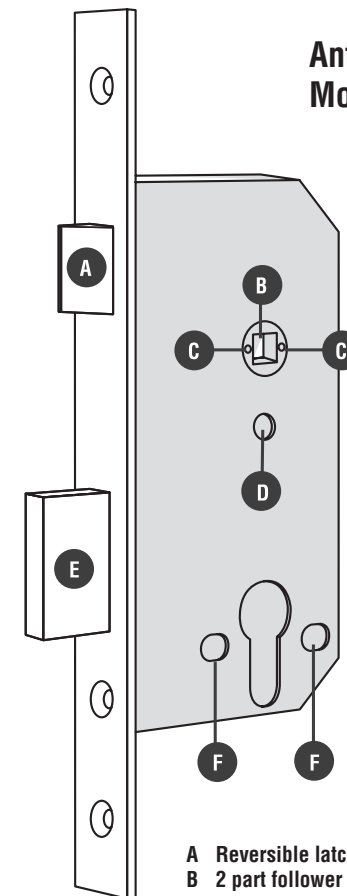

- A** Reversible latchbolt
- B** 2 part follower
- C** Set screws
- D** Hole for Codelock fixing bolt
- E** Double-throw 22mm ($\frac{7}{8}$ ") deadbolt
- F** Holes for keyhole-cover fixings

CL4020 INSTALLATION INSTRUCTIONS

- 1 Lightly mark a height line on the edge and both faces of the door, and the door jamb, to indicate the top of the lock when fitted. Mark a line down the centre of the door edge, extending above the height line and 300mm ($11\frac{13}{16}$ ") below it.
- 2 Hold the mortice lock template against the edge of the door with the top in line with the height line, and with the arrows in line with the 'Centre of Door Edge' line. Mark the positions of the fixing screws, and the holes to be drilled for the mortice.
- 3 Drill the marked holes 90mm ($3\frac{9}{16}$ ") deep and form the mortice for the lock.
- 4 Fold the template accurately along the dotted line and tape it to the door face with the top in line with the height line, and the fold on the door edge. Mark the centres of all the holes to be drilled. Remove the template and repeat on the other face of the door.
- 5 Drill the holes from both faces of the door to improve accuracy. Do not drill right through the door as this will damage the door when the drill breaks through.
- 6 Check that the 2 screws have been removed from the follower on the codeside of the door. DO NOT remove the screws from both sides of the follower.
- 7 Install the lock case in the door and fit the cylinder. Confirm that the key will double-throw the deadbolt, retract the deadbolt, and retract the latchbolt.
- 8 Fit the self-adhesive gaskets to the front and back plates. The gaskets provide friction against the door so that it is not necessary to over-tighten the bolts to provide stability.

- 9 Cut the fixing bolts to the correct length. Measured from beneath the bolt head the length should be 'door thickness plus approximately 15mm ($\frac{9}{16}$ ") to the nearest cutting point of the bolt.

N.B. Always cut the bolts at one of the reduced sections so as not to damage a thread. Use the cutting edge of pliers to crimp strongly several times around the selected cutting point. The surplus end should break off quite easily.

- 10 According to the door thickness, insert one of the short spindles into the codeside follower of the lock case with the spring facing out. Use the 22mm ($\frac{7}{8}$ ") spindle for doors between 35-50mm ($1\frac{3}{8}$ " - 2"), and the 28mm ($1\frac{1}{16}$ ") spindle for doors between 45-60mm ($1\frac{3}{4}$ " - $2\frac{3}{8}$ "). Insert the longest spindle into the inside follower with the spring facing out.
- 11 Remove the battery cover and the batteries from the back plate.
- 12 Position the front plate over the spindle, passing the cable through the door. Put both parts of the back plate in position with the spindle engaged in the follower and the cable pulled through.
- 13 Pass the top bolt through the door into the front plate, and then the bottom bolt, to stabilise the assembly.
- 14 Connect the cables. Fit the batteries and the battery cover. Fit the cylinder cover and the handles. The inside handle should retract the latchbolt, and the latchbolt should automatically project again when the handle is released. With the key turned 90° clockwise the outside handle should retract the latchbolt.
- 15 Enter the factory Master Code: Badge Bar **CODELOCKS.COM** 1234. The blue light will flash, and the handle will retract the latch.

CL4020 INSTALLATION INSTRUCTIONS

- 16 Mark a vertical line on the door jamb half the door thickness away from the door stop. This gives the centre line of the strike plate. Align the strike plate template with the height line, with the arrow heads aligned with the centre line. Mark the fixing holes, and draw around the apertures for the latchbolt and the deadbolt.
- 17 Chisel out the latch aperture to 12mm ($\frac{1}{2}$ ") deep, and the deadbolt aperture to 22mm ($\frac{7}{8}$ ") deep.
- 18 Fix the strike plate with the top screw only and gently close the door. Ensure that the latchbolt enters its aperture easily and holds the door without too much 'play'. When satisfied, draw around the final position of the strike plate, remove it, and cut a rebate to allow it to fit flush to the surface. Re-fix the strike with both screws.

CODELOCKS SUPPORT

All CL4000 documentation, as well as other ranges, can be found on our support site: www.codelockssupport.com.

Here you can view the documents online or easily download and print them off.

If you need advice regarding the installation or programming of your lock, call the Codelocks helpline on **0800 393 405**.



CODELOCKS UK HEADQUARTERS

Tel: +44 (0) 1635 239645
Fax: +44 (0) 1635 239644
sales@codelocks.co.uk
www.codelocks.co.uk

Helpline, service & spares
Freephone: 0800 393 405

CODELOCKS INC US

Tel: +1 714 979 2900
Fax: +1 714 979 2902
sales@codelocks.us
www.codelocks.us

Helpline, service & spares
Toll free: 1.877.codelock

CODELOCKS (Australia) PTY LTD

Tel: +61 2 9882 1009
Fax: +61 2 9882 6030
sales@codelocks.com.au
www.codelocks.com.au

Helpline, service & spares
Toll free: 1800 052 131



CODELOCKS

control + convenience

www.codelocks.com

