

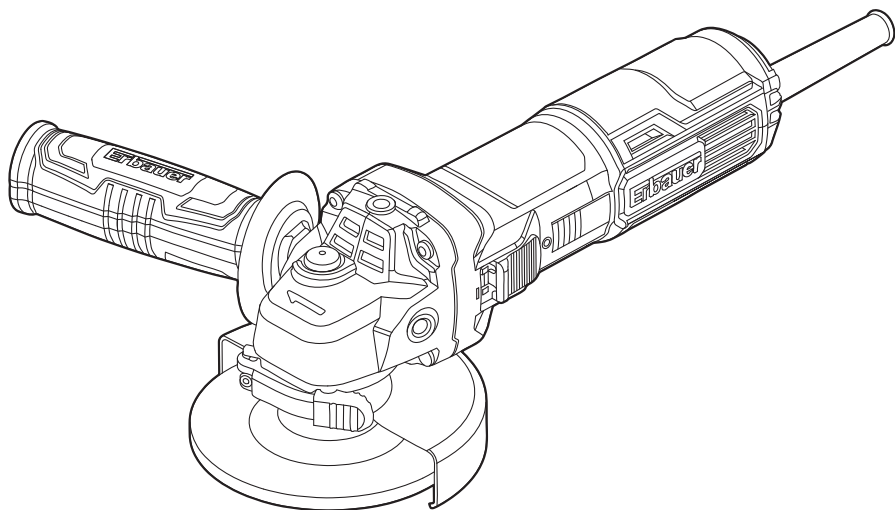

Erbauer



ERB977GRD

ORIGINAL INSTRUCTIONS

EN



Safety instructions



Product description



Assembly



Use



+



Care & maintenance



Guarantee



Declaration of Conformity



WARNING! Please read all safety warnings carefully and be sure that they are fully understood before handling the tool.

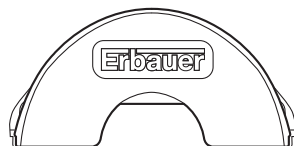
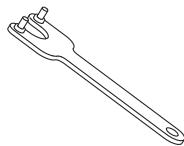
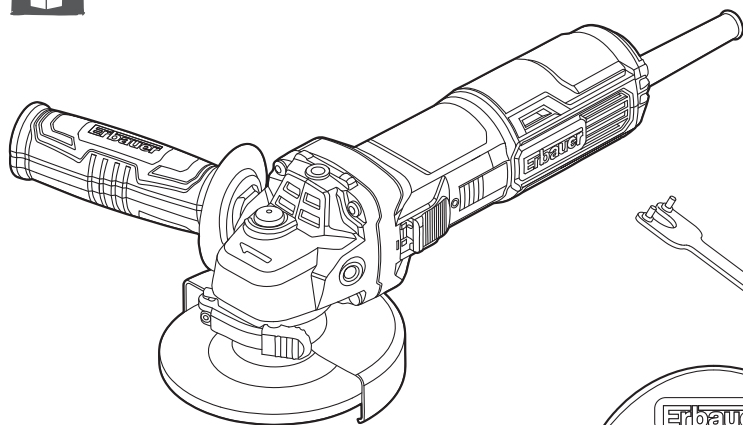



PRODUCT DESCRIPTION

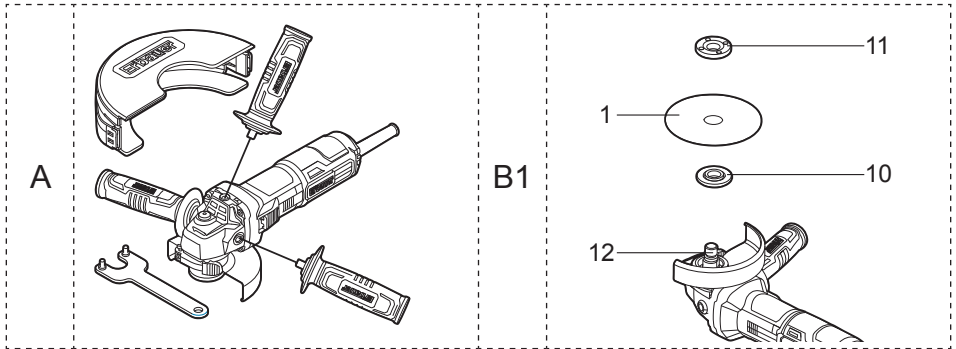
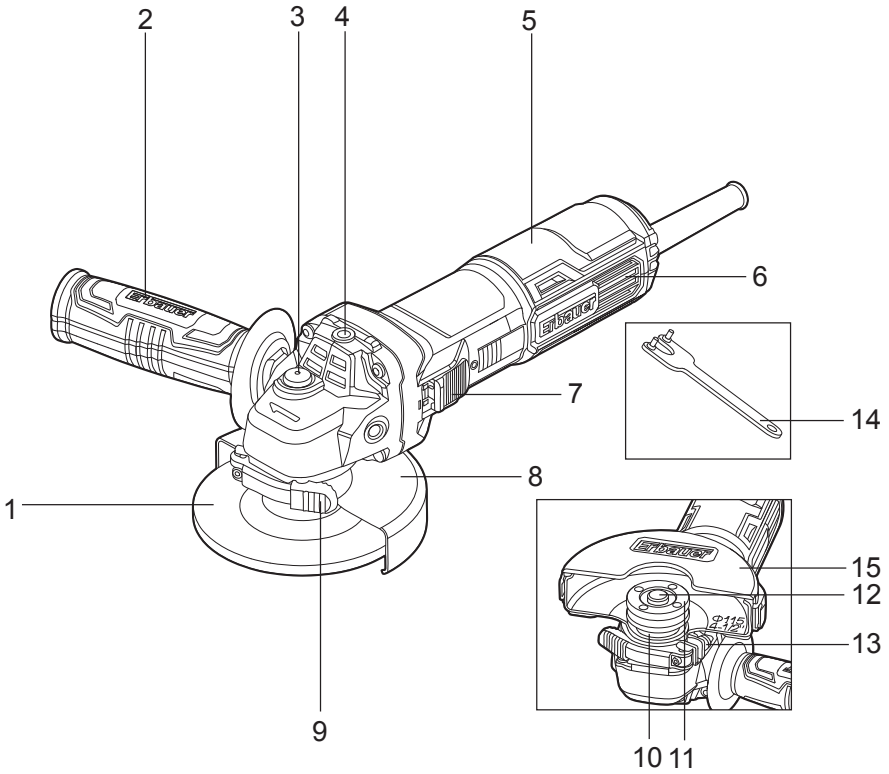

B2

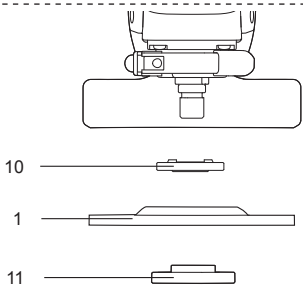

10

1

11

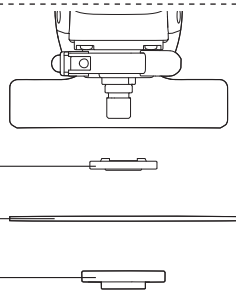

B3

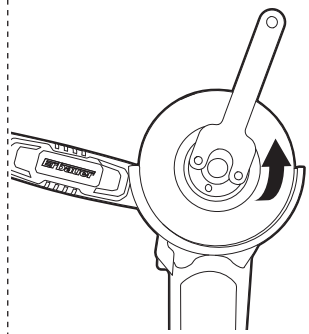

C

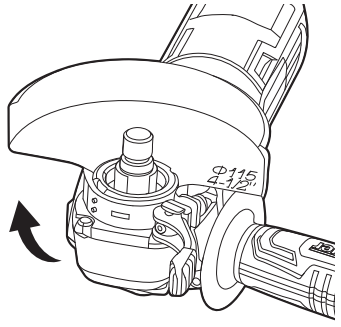

D

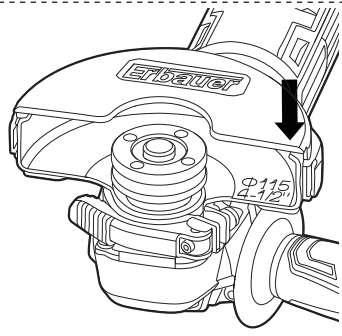

E

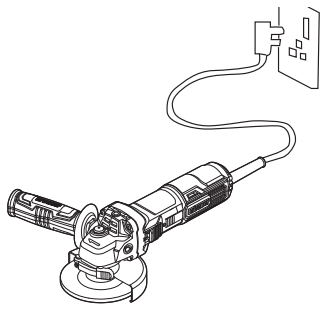

F

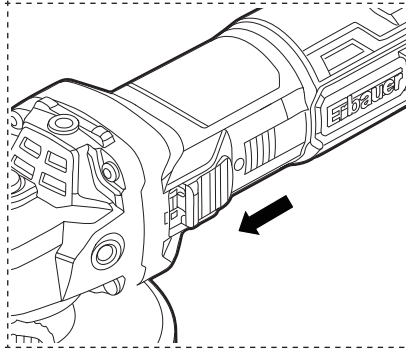

G

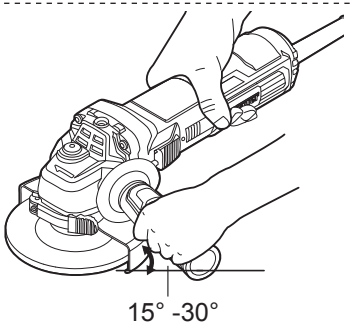

15° -30°

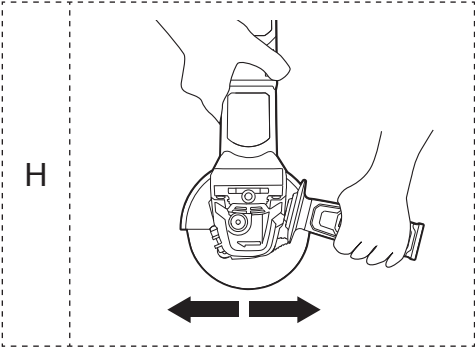



SAFETY INSTRUCTIONS

GENERAL POWER TOOL SAFETY WARNINGS



WARNING! Read all safety warnings and all instructions. *Failure to follow the warnings and instructions may result in electric shock, fire and/or serious injury.*

Save all warnings and instructions for future reference.

The term "power tool" in the warnings refers to your mains-operated (corded) power tool or battery-operated (cordless) power tool.

WORK AREA SAFETY

- a **Keep work area clean and well lit.** *Cluttered or dark areas invite accidents.*
- b **Do not operate power tools in explosive atmospheres, such as in the presence of flammable liquids, gases or dust.** *Power tools create sparks which may ignite the dust or fumes.*
- c **Keep children and bystanders away while operating a power tool.** *Distractions can cause you to lose control.*

ELECTRICAL SAFETY

- a **Power tool plugs must match the outlet. Never modify the plug in any way. Do not use any adapter plugs with earthed (grounded) power tools.** *Unmodified plugs and matching outlets will reduce risk of electric shock.*
- b **Avoid body contact with earthed or grounded surfaces, such as pipes, radiators, ranges and refrigerators.** *There is an increased risk of electric shock if your body is earthed or grounded.*

- c **Do not expose power tools to rain or wet conditions.** *Water entering a power tool will increase the risk of electric shock.*
- d **Do not abuse the cord. Never use the cord for carrying, pulling or unplugging the power tool. Keep cord away from heat, oil, sharp edges or moving parts.** *Damaged or entangled cords increase the risk of electric shock.*
- e **When operating a power tool outdoors, use an extension cord suitable for outdoor use.** *Use of a cord suitable for outdoor use reduces the risk of electric shock.*
- f **If operating a power tool in a damp location is unavoidable, use a residual current device (RCD) protected supply.** *Use of an RCD reduces the risk of electric shock.*

PERSONAL SAFETY

- a **Stay alert, watch what you are doing and use common sense when operating a power tool. Do not use a power tool while you are tired or under the influence of drugs, alcohol or medication.** *A moment of inattention while operating power tools may result in serious personal injury.*
- b **Use personal protective equipment. Always wear eye protection.** *Protective equipment such as a dust mask, non-skid safety shoes, hard hat, or hearing protection used for appropriate conditions will reduce personal injuries.*
- c **Prevent unintentional starting. Ensure the switch is in the off-position before connecting to power source and/or battery pack, picking up or carrying the tool.** *Carrying power tools with your finger on the switch or energising power tools that have the switch on invites accidents.*
- d **Remove any adjusting key or wrench before turning the power tool on.** *A wrench or a key left attached to a rotating part of the power tool may result in personal injury.*
- e **Do not overreach. Keep proper footing and balance at all times.** *This enables better control of the power tool in unexpected situations.*

- f Dress properly. Do not wear loose clothing or jewellery. Keep your hair, clothing away from moving parts.** *Loose clothes, jewellery or long hair can be caught in moving parts.*
- g If devices are provided for the connection of dust extraction and collection facilities, ensure these are connected and properly used.** *Use of dust collection can reduce dust-related hazards.*

POWER TOOL USE AND CARE

- a Do not force the power tool. Use the correct power tool for your application.** *The correct power tool will do the job better and safer at the rate for which it was designed.*
- b Do not use the power tool if the switch does not turn it on and off.** *Any power tool that cannot be controlled with the switch is dangerous and must be repaired.*
- c Disconnect the plug from the power source and/or remove the battery pack, if detachable, from the power tool before making any adjustments, changing accessories, or storing power tools.** *Such preventive safety measures reduce the risk of starting the power tool accidentally.*
- d Store idle power tools out of the reach of children and do not allow persons unfamiliar with the power tool or these instructions to operate the power tool.** *Power tools are dangerous in the hands of untrained users.*
- e Maintain power tools and accessories. Check for misalignment or binding of moving parts, breakage of parts and any other condition that may affect the power tools operation. If damaged, have the power tool repaired before use.** *Many accidents are caused by poorly maintained power tools.*
- f Keep cutting tools sharp and clean.** *Properly maintained cutting tools with sharp cutting edges are less likely to bind and are easier to control.*

- g Use the power tool, accessories and tool bits etc. in accordance with these instructions, taking into account the working conditions and the work to be performed. Use of the power tool for operations different from those intended could result in a hazardous situation.**

SERVICE

- a Have your power tool serviced by a qualified repair person using only identical replacement parts. This will ensure that the safety of the power tool is maintained.**

SAFETY INSTRUCTIONS FOR ALL OPERATIONS

SAFETY WARNINGS COMMON FOR GRINDING OR ABRASIVE CUTTING-OFF OPERATIONS:

- a This power tool is intended to function as a grinder or cut-off tool. Read all safety warnings, instructions, illustrations and specifications provided with this power tool. Failure to follow all instructions listed below may result in electric shock, fire and/or serious injury.**
- b Operations such as sanding, wire brushing, polishing are not recommended to be performed with this power tool. Operations for which the power tool was not designed may create a hazard and cause personal injury.**
- c Do not use accessories which are not specifically designed and recommended by the tool manufacturer. Just because the accessory can be attached to your power tool, it does not assure safe operation.**
- d The rated speed of the accessory must be at least equal to the maximum speed marked on the power tool. Accessories running faster than their rated speed can break and fly apart.**
- e The outside diameter and the thickness of your accessory must be within the capacity rating of your power tool. Incorrectly sized accessories cannot be adequately guarded or controlled.**

- f Threaded mounting of accessories must match the grinder spindle thread. For accessories mounted by flanges, the arbour hole of the accessory must fit the locating diameter of the flange. *Accessories that do not match the mounting hardware of the power tool will run out of balance, vibrate excessively and may cause loss of control.***
- g Do not use a damaged accessory. Before each use inspect the accessory such as abrasive wheels for chips and cracks, backing pad for cracks, tear or excess wear. If power tool or accessory is dropped, inspect for damage or install an undamaged accessory. After inspecting and installing an accessory, position yourself and bystanders away from the plane of the rotating accessory and run the power tool at maximum no-load speed for one minute. *Damaged accessories will normally break apart during this test time.***
- h Wear personal protective equipment. Depending on application, use face shield, safety goggles or safety glasses. As appropriate, wear dust mask, hearing protectors, gloves and workshop apron capable of stopping small abrasive or workpiece fragments. *The eye protection must be capable of stopping flying debris generated by various operations. The dust mask or respirator must be capable of filtering particles generated by your operation. Prolonged exposure to high intensity noise may cause hearing loss.***

- i **Keep bystanders a safe distance away from work area.** *Anyone entering the work area must wear personal protective equipment. Fragments of workpiece or of a broken accessory may fly away and cause injury beyond immediate area of operation.*
- j **Hold power tool by insulated gripping surfaces only, when performing an operation where the cutting accessory may contact hidden wiring or its own cord.** *Cutting accessory contacting a “live” wire may make exposed metal parts of the power tool “live” and could give the operator an electric shock.*
- k **Position the cord clear of the spinning accessory.** *If you lose control, the cord may be cut or snagged and your hand or arm may be pulled into the spinning accessory.*
- l **Never lay the power tool down until the accessory has come to a complete stop.** *The spinning accessory may grab the surface and pull the power tool out of your control.*
- m **Do not run the power tool while carrying it at your side.** *Accidental contact with the spinning accessory could snag your clothing, pulling the accessory into your body.*
- n **Regularly clean the power tool’s air vents.** *The motor’s fan will draw the dust inside the housing and excessive accumulation of powdered metal may cause electrical hazards.*
- o **Do not operate the power tool near flammable materials.** *Sparks could ignite these materials.*
- p **Do not use accessories that require liquid coolants.** *Using water or other liquid coolants may result in electrocution or shock.*

KICKBACK AND RELATED WARNINGS

Kickback is a sudden reaction to a pinched or snagged rotating wheel, backing pad, brush or any other accessory. Pinching or snagging causes rapid stalling of the rotating accessory which in turn causes the uncontrolled power tool to be forced in the direction opposite of the accessory's rotation at the point of the binding.

For example, if an abrasive wheel is snagged or pinched by the workpiece, the edge of the wheel that is entering into the pinch point can dig into the surface of the material causing the wheel to climb out or kick out. The wheel may either jump toward or away from the operator, depending on direction of the wheel's movement at the point of pinching. Abrasive wheels may also break under these conditions.

Kickback is the result of power tool misuse and/or incorrect operating procedures or conditions and can be avoided by taking proper precautions as given below.

- a Maintain a firm grip on the power tool and position your body and arm to allow you to resist kickback forces. Always use auxiliary handle, if provided, for maximum control over kickback or torque reaction during start-up.**
The operator can control torque reactions or kickback forces, if proper precautions are taken.
- b Never place your hand near the rotating accessory.**
Accessory may kickback over your hand.
- c Do not position your body in the area where power tool will move if kickback occurs.** *Kickback will propel the tool in direction opposite to the wheel's movement at the point of snagging.*
- d Use special care when working corners, sharp edges etc. Avoid bouncing and snagging the accessory.** *Corners, sharp edges or bouncing have a tendency to snag the rotating accessory and cause loss of control or kickback.*
- e Do not attach a saw chain woodcarving blade or toothed saw blade.** *Such blades create frequent kickback and loss of control.*

ADDITIONAL SAFETY INSTRUCTIONS FOR GRINDING AND CUTTING-OFF OPERATIONS

SAFETY WARNINGS SPECIFIC FOR GRINDING AND ABRASIVE CUTTING-OFF OPERATIONS:

- a Use only wheel types that are recommended for your power tool and the specific guard designed for the selected wheel.** *Wheels for which the power tool was not designed cannot be adequately guarded and are unsafe.*
- b The grinding surface of centre depressed wheels must be mounted below the plane of the guard lip.** *An improperly mounted wheel that projects through the plane of the guard lip cannot be adequately protected.*
- c The guard must be securely attached to the power tool and positioned for maximum safety, so the least amount of wheel is exposed towards the operator.** *The guard helps to protect operator from broken wheel fragments, accidental contact with wheel and sparks that could ignite clothing.*
- d Wheels must be used only for recommended applications. For example: do not grind with the side of cut-off wheel.** *Abrasive cut-off wheels are intended for peripheral grinding, side forces applied to these wheels may cause them to shatter.*
- e Always use undamaged wheel flanges that are of correct size and shape for your selected wheel.** *Proper wheel flanges support the wheel thus reducing the possibility of wheel breakage. Flanges for cut-off wheels may be different from grinding wheel flanges.*
- f Do not use worn down wheels from larger power tools.** *Wheel intended for larger power tool is not suitable for the higher speed of a smaller tool and may burst.*

ADDITIONAL SAFETY INSTRUCTIONS FOR CUTTING-OFF OPERATIONS

ADDITIONAL SAFETY WARNINGS SPECIFIC FOR ABRASIVE CUTTING-OFF OPERATIONS:

- a **Do not “jam” the cut-off wheel or apply excessive pressure. Do not attempt to make an excessive depth of cut.** *Overstressing the wheel increases the loading and susceptibility to twisting or binding of the wheel in the cut and the possibility of kickback or wheel breakage.*
- b **Do not position your body in line with and behind the rotating wheel.** *When the wheel, at the point of operation, is moving away from your body, the possible kickback may propel the spinning wheel and the power tool directly at you.*
- c **When wheel is binding or when interrupting a cut for any reason, switch off the power tool and hold the power tool motionless until the wheel comes to a complete stop. Never attempt to remove the cut-off wheel from the cut while the wheel is in motion otherwise kickback may occur.** *Investigate and take corrective action to eliminate the cause of wheel binding.*
- d **Do not restart the cutting operation in the workpiece. Let the wheel reach full speed and carefully re-enter the cut.** *The wheel may bind, walk up or kickback if the power tool is restarted in the workpiece.*
- e **Support panels or any oversized workpiece to minimize the risk of wheel pinching and kickback.** *Large workpieces tend to sag under their own weight. Supports must be placed under the workpiece near the line of cut and near the edge of the workpiece on both sides of the wheel.*
- f **Use extra caution when making a “pocket cut” into existing walls or other blind areas.** *The protruding wheel may cut gas or water pipes, electrical wiring or objects that can cause kickback.*

The following information applies to professional users only but is good practice for all users:

ADDITIONAL SAFETY WARNING FOR CONSTRUCTION DUST

The updated Control of Substances Hazardous to Health Regulations 1st October 2012 now also targets to reduce the risks associated with silica, wood and gypsum dusts.

Construction workers are one of the at-risk groups within this because of the dust that they breathe: silica dust is not just a nuisance; it is a real risk to your lungs!

Silica is a natural mineral present in large amounts in things like sand, sandstone and granite. It is also commonly found in many construction materials such as concrete and mortar. The silica is broken into very fine dust (also known as Respirable Crystalline Silica or RCS) during many common tasks such as cutting, drilling and grinding Breathing in very fine particles of crystalline silica can lead to the development of: Lung cancer Silicosis Chronic Obstructive Pulmonary Disorder Chronic obstructive pulmonary disease (COPD) And breathing in fine particles of wood dust can lead to the development of Asthma The risk of lung disease is linked to people who regularly breathe construction dust over a period of time, not on the odd occasion.

To protect the lung, the COSHH Regulations sets a limit on the amount of these dusts that you can breathe (called a Workplace Exposure Limit or WEL) when averaged over a normal working day. These limits are not a large amount of dust: when compared to a penny it is tiny – like a small pinch of salt:

This limit is the legal maximum; the most you can breathe after the right controls have been used.

HOW TO REDUCE THE AMOUNT OF DUST?

1. Reduce the amount of cutting by using the best sizes of building products.
2. Use a less powerful tool e.g. a block cutter instead of angle grinder.
3. Using a different method of work altogether – e.g. using a nail gun to direct fasten cable trays instead of drilling holes first.

Please always work with approved safety equipment, such as those dust masks that specially designed to filter out microscopic particles and use the dust extraction facility at all time.

For more information please see the HSE website: <http://www.hse.gov.uk/construction> or <http://www.hse.gov.uk/pubns/cis69.pdf>



WARNING! Some dust particles created by power sanding, sawing, grinding, drill and other construction jobs contain chemicals known to cause cancer, birth defects or other reproductive harm. Some examples of these chemicals are:

- Lead from lead-based paints.
- Crystalline silica from bricks and cement and other masonry products.
- Arsenic and chromium from chemically treated timber.
- Your risk from these exposures varies, depending upon how often you do this type of work. To reduce your exposure to these chemicals:
 - Work in a well-ventilated area.
 - Work with approved safety equipment, such as those dust masks that are specially designed to filter microscopic particles.

VIBRATION

The European Physical Agents (Vibration) Directive has been brought in to help reduce hand arm vibration syndrome injuries to power tool users. The directive requires power tool manufacturers and suppliers to provide indicative vibration test results to enable users to make informed decisions as to the period of time a power tool can be used safely on a daily basis and the choice of tool.

SEE TECHNICAL SPECIFICATIONS IN THE INSTRUCTION MANUAL FOR THE VIBRATION LEVELS OF YOUR TOOL.

The declared vibration emission value should be used as a minimum level and should be used with the current guidance on vibration.

Calculating the actual period of use can be difficult and the HSE website has further information.

The declared vibration emission has been measured in accordance with EN 60745-1 & EN 60745-2-3 and may be used to compare one tool with another tool.

The declared vibration emission value may also be used in preliminary assessment of exposure.



WARNING! The vibration emission value during actual use of the power tool can differ from the declared value depending on the ways in which the tool is used dependant on the following examples and other variations on how the tool is used:

- How the tool is used and the materials being cut or drilled.
- The tool being in good condition and well maintained.
- Use the correct accessories for the tool and ensure they are sharp and in good condition.
- The tightness of the grip on the handles.
- The tool is being used as intended by its design and these instructions.



WARNING! Identify safety measures to protect the operator that are based on an estimation of exposure in the actual conditions of use (taking account of all parts of the operating cycle such as the times when the tool is switched off and when it is running idle in addition to the trigger time).

While working with this power tool, hand/arm vibrations occur. Adopt the correct working practices in order to reduce the exposure to vibration. This tool may cause hand-arm vibration syndrome if its use is not adequately managed.

Helping to minimise your vibration exposure risk. ALWAYS use sharp chisels, drills and blades.

Maintain this tool in accordance with these instructions and keep well lubricated (where appropriate).

Avoid using tools in temperatures of 10°C or less. Plan your work schedule to spread any high vibration tool use across a number of days.



NOTE: The use of other tools will reduce the users' total working period on this tool.

HEALTH SURVEILLANCE

All employees should be part of an employer's health surveillance scheme to help identify any vibration related diseases at an early stage, prevent disease progression and help employees stay in work.



PRODUCT DESCRIPTION

- | | |
|--|----------------------------|
| 1. Grinding/Cutting wheel (not included) | 9. Guard clamping lever |
| 2. Auxiliary handle | 10. Inner flange |
| 3. Spindle lock button | 11. Outer flange |
| 4. Mounting threads (×3) | 12. Spindle |
| 5. Gripping surface | 13. Clamp adjustment screw |
| 6. Air vents | 14. Spanner |
| 7. ON /OFF switch | 15. Cutting safety guard |
| 8. Grinding safety guard | |

01 TECHNICAL SPECIFICATIONS

Rated voltage, frequency:	220 – 240 V~ ,50 Hz
Rated power input:	750 W
Rated speed n:	12200/min
Protection class:	II / 
Spindle thread	M14
Maximum wheel diameter	Ø 115 mm
Maximum thickness of grinding wheel	6mm
Wheel bore	Ø 22.23 mm
Machine weight	2.12kg

NOISE DATA

A weighted sound pressure:	L_{pA} : 92.0 dB (A)
A weighted sound power:	L_{WA} : 103.0 dB (A)
Uncertainty:	K_{PA} & K_{WA} =3.0 dB(A)

The noise for the operator may exceed 80 dB(A) and ear protection measures are necessary

VIBRATION DATA

Surface grinding	$a_{h,AG} = 7.0 \text{ m/s}^2$ (Main handle);
	$a_{h,AG} = 9.4 \text{ m/s}^2$ (Aux. handle)
Uncertainty	$K = 1.5 \text{ m/s}^2$

RATING LABEL EXPLANATION**ERB977GRD=MODEL NUMBER****ERB**=Erbauer**977**=Serial number**GRD**=ANGLE GRINDER



ASSEMBLY

01 SYMBOLS



Read the instruction manual



Wear eye protection



Wear protective gloves.



Wear hearing protection.



Wear a dust mask.



Wear protective, slip resistant footwear. Switch the product off and disconnect it from the power supply before assembly, cleaning, adjustments, maintenance, storage and transportation.



Class II tool



3 metre Power Cord Length

yyWxx

Manufacturing date code: Year of manufacturing (20yy) and week of manufacturing (Wxx)



The product complies with the applicable European directives and an evaluation method of conformity for these directives was done.



UK Conformity Assessed.



WEEE symbol. Waste electrical products should not be disposed of with household waste. Please recycle where facilities exist. Check with your Local Authority or local store for recycling advice.

02 UNPACKING

Unpack all parts and lay them on a flat, stable surface.

- Remove all packing materials and shipping devices, if applicable.
- Make sure the delivery contents are complete and free of any damage. If you find that parts are missing or show damage do not use the product but contact your dealer. Using an incomplete or damaged product represents a hazard to people and property.
- Ensure that you have all the accessories and tools needed for assembly and operation. This also includes suitable personal protective equipment



WARNING! The product and the packaging are not children's toys!

Children must not play with plastic bags, sheets and small parts! There is a danger of choking and suffocation!

03 ASSEMBLING THE MACHINE

AUXILIARY HANDLE (A)

For all work with the machine, the auxiliary handle (2) must be mounted. Screw the auxiliary handle (2) in one of the mounting threads (4) of the machine head depending on the working method.



WARNING! Do not make any alterations to the auxiliary handle. Do not continue to use an auxiliary handle if it is damaged.

MOUNTING THE GRINDING/CUTTING WHEELS

Before any work on the machine itself, remove the mains plug from socket outlet.

Grinding and cutting wheels become very hot while working, do not touch until they have cooled.

1. Spindle lock button

Clean the grinder spindle and all parts to be mounted. For clamping and loosening the wheels, lock the grinder spindle (12) with the spindle lock button (3).



WARNING! Actuate the spindle lock button (3) only when the grinder spindle is at a standstill!

2. Adjustable outer flange clamping (B1, B2)

The outer flange (11) should be adjusted to suit different wheel thickness. For thinner cutting or diamond wheels the raised part of the outer flange is fitted facing away from

the wheel. For thicker grinding wheels the raised part of the outer flange is fitted facing towards the wheel to provide improved support for the wheel hole. Always ensure your wheel is securely clamped.

3. Grinding/Cutting Wheel (B3)

Pay attention to the dimensions of the grinding wheel. The mounting hole diameter must fit the inner flange (10) without play. Do not use reducers or adapters.

When using a diamond cutting wheel, take care that the direction-of-rotation arrow on the diamond cutting wheel and the direction of rotation of the machine (direction-of-rotation arrow on the machine head) agree.

Screw on the outer flange (11) and tighten with the two-pin spanner (14).

ADJUSTING THE SAFETY GUARD (C)

For work with grinding or cutting wheels, the safety guard must be mounted.

Open the clamping lever (9). Place the safety guard (8) with coded projection into the coded groove on the spindle of the machine head and rotate to the required position (working position).

To fasten the safety guard (8), close the clamping lever and loosen the clamp adjustment screw (13), if necessary. The closed side of the safety guard (8) must always point to the operator.



NOTE: With the clamping lever (9) open, the clamp adjustment screw (13) can be adjusted to ensure the guard is securely clamped after the clamping lever (9) is finally closed.

WHEEL GUARD FOR CUTTING (D)



WARNING! For cutting metal, always work with the wheel guard for cutting. For grinding, always work with the wheel guard for grinding.

For cutting-off application, position the front cover with the closed side on the cutting guard and push it on until it engages.

CONNECT TO POWER SUPPLY

1. Make sure the on/off switch(7)is not pressed.
2. Connect the plug with a suitable power socket.



WARNING! Check the voltage! The voltage must comply with the information on the rating label!

3. Your product is now ready to be used.



USE

01 INTENDED USE

The machine is intended for cutting and grinding metal and stone materials without using water. For cutting, a special safety guard for cutting (accessory) must be used.



WARNING! Always switch the product off and disconnect it from power supply before making any adjustments!

02 OPERATION

OPERATING INSTRUCTIONS

- Clamp the workpiece if it does not remain stationary due to its own weight.
- Do not strain the machine so heavily that it comes to a standstill.
- Grinding and cutting wheels become very hot while working, do not touch until they have cooled.
- Pull the plug from the socket-outlet when not using the machine. With the plug inserted and mains voltage applied, the power tool still has low power consumption even when it is switched off. (E)

STARTING OPERATION (F)

To start the power tool, push the on/off switch (7) forward.

To lock the on/off switch (7), press the on/off switch (7) down at the front until it engages.

To switch off the power tool, release the on/off switch (7) or, if it is locked, briefly push down the back of the on/off switch (7) and then release it.

1. Hand grip areas

Always hold your angle grinder firmly with both hands when operating (G).

2. Grinding (G)

The best grinding results are achieved when setting the machine at an angle of 15° to 30°. Move the machine back and forth with moderate pressure. In this manner, the workpiece will not become too hot, does not discolour and no grooves are formed.



WARNING! Never use a cutting wheel for grinding.

3. Cutting (H)

When cutting, do not press, tilt or oscillate the machine. Work with moderate feed, adapted to the material being cut.

Do not reduce the speed of running down cutting wheels by applying sideward pressure. The direction in which the cutting is performed is important. The machine must always work in an up-grinding motion. Therefore, never move the machine in the other direction! Otherwise, the danger exists of it being pushed uncontrolled out of the cut.



WARNING! For cutting, always work with the wheel guard for cutting.

WORKING HINTS FOR YOUR ANGLE GRINDER

If your power tool becomes too hot, run no load for 2-3 minutes to cool the motor. Never start your angle grinder with the wheel/ accessory in contact with the workpiece. Always start at no load to achieve maximum speed then start working.

Do not force the wheel to work faster, reducing the wheel's moving speed means longer working time.

When grinding, always work with a 30° to 40° angle between wheel and workpiece. Larger angles will cut ridges into the workpiece and affect the surface finish. Move the angle grinder across and back and forth over the workpiece.

When using a cutting wheel, never change the cutting angle otherwise you will stall the wheel and angle grinder motor or break the wheel.

When cutting, only cut in the opposite direction to the wheel rotation. If you cut in the same direction as the wheel rotation the wheel may push itself out of the cut slot.

When cutting very hard material best results can be achieved with a diamond wheel. When using a diamond wheel it will become very hot. If this happens you will see a full ring of sparks around the rotating wheel. Stop cutting and allow cooling at no load speed for 2-3 minutes.

Always ensure the workpiece is firmly held or clamped to prevent movement.



CARE & MAINTENANCE

THE GOLDEN RULES FOR CLEANING



WARNING! Always switch the product off, disconnect the product from the power supply and let the product cool down before performing inspection, maintenance and cleaning work!

- Keep the product clean. Remove debris and dust from it after each use and before storage.
- Regular and proper cleaning will help ensure safe use and prolong the life of the product.



WARNING! Only perform repairs and maintenance work according to these instructions! All further works must be performed by a qualified specialist!

- Inspect the product before each use for worn and damaged parts. Do not operate it if you find broken and worn parts.

GENERAL CLEANING

- Clean the product with a dry cloth. Use a brush for areas that are hard to reach.
- In particular clean the air vents after every use with a cloth and brush.
- Remove stubborn dirt with high pressure air (max. 3 bar).



WARNING! Do not use chemical, alkaline, abrasive or other aggressive detergents or disinfectants to clean this product as they might be harmful to its surfaces.

- Check for worn or damaged parts. Replace worn parts as necessary or contact an authorised service centre for repair before using the product again.

MAINTENANCE

Before and after each use, check the product and accessories (or attachments) for wear and damage. If required, exchange them for new ones as described in this instruction manual. Observe the technical requirements.

POWER CORD

If the replacement of the **supply cord** is necessary, this has to be done by the manufacturer or his agent in order to avoid a safety hazard.

PLUG REPLACEMENT

If you need to replace the fitted plug, then follow the instructions below.

IMPORTANT: The wires in the mains lead are coloured in accordance with the following code:

Blue – Neutral Brown – Live

As the colours of the wire in the mains lead of this product may not correspond with the coloured marking identifying the terminals in your plug, proceed as follows. The wire, which is coloured blue, must be connected to the terminal, which is marked with N or coloured black. The wire, which is coloured brown, must be connected to the terminal, which is marked L or coloured red.

13AMP fuse approved to BS 1362

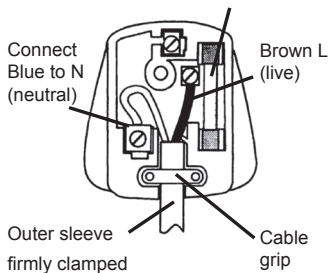

WARNING! Never connect live or neutral wires to the earth terminal of the plug, which is marked with E.

Only fit an approved 13 Amp BS1363 or BS1363/A plug and the correctly rated fuse. If in doubt, consult a qualified electrician.



NOTE: If a moulded plug is fitted and must be removed take great care in disposing of the plug and severed cable, it must be destroyed to prevent engaging into a socket.

RECYCLING AND DISPOSAL



Waste electrical products should not be disposed of with household waste.

Please recycle where facilities exist. Check with your Local Authority or retailer for recycling advice. For further information visit

www.recycle-more.co.uk

REPAIR

This product does not contain any parts that can be repaired by the consumer. Contact a qualified specialist to have it checked and repaired.

STORAGE

- Clean the product as described above.
- Store the product and its accessories in a dry, frost-free place.
- Always store the product in a place that is inaccessible to children. The ideal storage temperature is between 10 and 30°C.
- We recommend using the original package for storage or covering the product with a suitable cloth to protect it against dust.

TRANSPORTATION

- Switch the product off and disconnect it from power supply before transporting it any where.
- Attach transportation guards, if applicable.
- Secure the product to prevent it from slipping or falling over.
- Protect the product from any heavy impact or strong vibrations which may occur during transportation in vehicles.



GUARANTEE

We take special care to select high quality materials and use manufacturing techniques that allow us to create products incorporating design and durability. This product (**Erbauer** Angle grinder) has a manufacturer's guarantee of 3 years against manufacturing defects, from the date of purchase (if bought in store) or date of delivery (if bought online), at no additional cost.

To make a claim under this guarantee, you must present your proof of purchase (such as a sales receipt, purchase invoice or other evidence admissible under applicable law), please keep your proof of purchase in a safe place. For this guarantee to apply, the product you purchased must be new, it will not apply to second hand or display products. Unless stated otherwise by applicable law, any replacement product issued under this guarantee will only be guaranteed until expiry of the original period guarantee period.

This guarantee covers product failures and malfunctions provided the product was used for the purpose for which it is intended and subject to installation, cleaning, care and maintenance in accordance with the information contained in these terms and conditions, in the user manual and standard practice, provided that standard practice does not conflict with the user manual.

This guarantee does not cover defects and damage caused by normal wear and tear or damage that could be the result of improper use, faulty installation or assembly, neglect, accident, misuse, or modification of the product. Unless stated otherwise by applicable law, this guarantee will not cover, in any case, ancillary costs (shipping, movement, costs of uninstalling and reinstalling, labour etc), or direct and indirect damage.

This guarantee does not cover defects and damage caused by or resulting from:

Normal wear and tear

Overload, misuse or neglect

Repairs attempted by anyone other than an authorised agent

Cosmetic damage

Damage caused by foreign objects, substances or accidents

Accidental damage or modification

Failure to follow manufacturer's guidelines

Loss of use of the goods

If the product is defective, we will, within a reasonable time, repair or replace it.

Rights under this guarantee are enforceable in the country in which you purchased this product. Guarantee related queries should be addressed to the store you purchased this product from.

The guarantee is in addition to and does not affect your statutory rights.



DECLARATION OF CONFORMITY

UK CA

(UK) DECLARATION OF CONFORMITY

Product

- Angle grinderr
- ERB977GRD
- Serial number 00001-99999

Name and address of the manufacturer or his authorised representative:

Kingfisher International Products Limited
3 Sheldon Square
London W2 6PX
United Kingdom

This declaration of conformity is issued under the sole responsibility of the manufacturer.

Object of the declaration

Product	Model	EAN
Angle grinder	ERB977GRD	5063022091635

The object of the declaration described above is in conformity with the relevant legislation:

Supply of Machinery (Safety) Regulations 2008 as amended
Electromagnetic Compatibility Regulations 2016 as amended
The Restriction of the use of Certain Hazardous Substances in Electrical and Electronic Equipment Regulations 2012 as amended

References to the relevant designated standards used or references to the other technical specifications in relation to which conformity is declared:

EN 60745-1:2009+A11:2010	BS EN 60745-1:2009+A11:2010
EN 60745-2-3: 2011+A2:2013	BS EN 60745-2-3:2011+A13:2015
+A11:2014+A12:2014+A13:2015	BS EN IEC 55014-1:2021
EN IEC 55014-1:2021	BS EN IEC 55014-2:2021
EN IEC 55014-2:2021	BS EN IEC 61000-3-2:2019+A1:2021
EN IEC 61000-3-2:2019+A1:2021	BS EN 61000-3-3:2013+A1:2019+A2:2021
EN 61000-3-3:2013+A1:2019+A2:2021	

Authorized Signatory and technical file holder
Kingfisher International Products Limited
3 Sheldon Square
London W2 6PX
United Kingdom

David Awe
Group Quality Director

28/03/2023



**(EN) EU DECLARATION OF CONFORMITY
(FR) DÉCLARATION UE DE CONFORMITÉ
(PL) DEKLARACJA ZGODNOŚCI UE
(RO) DECLARAȚIA DE CONFORMITATE UE
(ES) DECLARACIÓN UE DE CONFORMIDAD
(PT) DECLARAÇÃO DE CONFORMIDADE UE**

Product/ Produit/ Produkt/Produsul/Producto/Produto

- Angle grinder/Meuleuse/Szlifierka kątowa/Polizor unghiular/Amoladora angular/
Máquina de afiar angular
- ERB977GRD
- Serial number 00001-99999

Name and address of the manufacturer or his authorised representative:

Nom et adresse du fabricant ou de son mandataire:

Nazwa i adres producenta lub jego upoważnionego przedstawiciela:

Denumirea și adresa producătorului sau a reprezentantului său autorizat:

Nombre y dirección del fabricante o de su representante autorizado:

Nome e endereço do fabricante ou do respetivo mandatário:

Kingfisher International Products B.V.,
Rapenburgerstraat 175E,
1011 VM Amsterdam,
The Netherlands

This declaration of conformity is issued under the sole responsibility of the manufacturer.

La présente déclaration de conformité est établie sous la seule responsabilité du fabricant.

Niniejsza deklaracja zgodności wydana zostaje na wyłączną odpowiedzialność producenta.

Prezenta declarație de conformitate este emisă pe răspunderea exclusivă a producătorului.

La presente declaración de conformidad se expide bajo la exclusiva responsabilidad del fabricante.

A presente declaração de conformidade é emitida sob a exclusiva responsabilidade do fabricante.

Object of the declaration/ Objet de la déclaration/ Przedmiot deklaracji/ Obiectul declarației/ Objeto de la declaración/ Objeto da declaração

Product/ Produit/ Produkt/Produsul/
Producto/ Produto

Model/ Modèle/ Model/
Modelul/ Modelo/ Modelo

EAN

Angle grinder/Meuleuse/Szlifierka k towa/
Polizor unghiular/Amoladora angular/
Máquina de afiar angular

ERB977GRD

5063022091635

The object of the declaration described above is in conformity with the relevant Union harmonisation legislation:

L'objet de la déclaration décrit ci-dessus est conforme à la législation d'harmonisation de l'Union applicable:

Wymieniony powyżej przedmiot niniejszej deklaracji jest zgodny z odnośnymi wymaganiami unijnego prawodawstwa harmonizacyjnego:

Obiectul declarației descris mai sus este în conformitate cu legislația relevantă de armonizare a Uniunii:
El objeto de la declaración descrita anteriormente es conforme con la legislación de armonización pertinente de la Unión:

O objeto da declaração acima descrito está em conformidade com a legislação de harmonização da União aplicável:

2006/42/EC as amended	Machinery Directive
2014/30/EU as amended	Directive Electromagnetic compatibility
2011/65/EU as amended	Directive Restriction of the use of certain hazardous substances in electrical and electronic equipment
Directive 2006/42/CE relative aux machines	
2014/30 / UE telle que modifiée Directive Compatibilit�� electromagn��tique	
Directive 2011/65/UE relative �� la limitation de l'utilisation de certaines substances dangereuses dans les ��quipements ��lectriques et ��lectroniques	
2006/42/WE w zmienionej dyrektywie maszynowej	
2014/30 / UE ze zmianami Dyrektywa Kompatybilno�� elektromagnetyczna	
2011/65 / UE ze zmianami Dyrektywa Ograniczenie stosowania niekt��rych niebezpiecznych substancji w sprz��cie elektrycznym i elektronicznym	
2006/42/CE, astfel a fost modificat�� Directiva privind echipamentele	
2014/30/UE, astfel a fost modificat�� Directiva privind compatibilitatea electromagnetic��	
2011/65/UE, astfel a fost modificat�� Directiva privind limitarea utiliz��rii anumitor substan��e periculoase ��n echipamentele electrice ��i electronice	
Directiva sobre maquinaria modificada 2006/42/CE	
2014/30/UE modificada Directiva Compatibilitad electromagn��tica	
2011/65/UE modificada Directiva Restricci��n del uso de determinadas sustancias peligrosas en equipos el��ctricos y electr��nicos	
2006/42/CE como diretiva de m��quinas alteradas	
2014/30/UE como altera��o da compatibilidade eletromagn��tica	
2011/65/UE como restri��o diretiva alterada da utiliza��o de certas subst��ncias perigosas em equipamentos el��tricos e eletr��nicos	
References to the relevant harmonised standards used or references to the other technical specifications in relation to which conformity is declared:	
R��f��rences des normes harmonis��es pertinentes appliqu��es, y compris la date de celles-ci, ou des autres caract��ristiques techniques, y compris la date de celles-ci, par rapport auxquelles la conformit�� est d��clar��e:	
Odwołania do odno��nych norm zharmonizowanych, kt��re zastosowano, wraz z dat�� normy, lub do innych specyfikacji technicznych, wraz z dat�� specyfikacji, w odniesieniu do kt��rych deklarowana jest zgodno��c:	
Trimiteri la standardele armonizate relevante folosite, inclusiv data standardului, sau trimiteri la celelalte specifica��ii tehnice, inclusiv data specifica��iilor, ��n leg��tur�� cu care se declar�� conformitatea:	
Referencias a las normas armonizadas pertinentes utilizadas, incluidas las fechas de las normas, o referencias a las otras especificaciones t��cnicas, incluidas las fechas de las especificaciones, respecto a las cuales se declara la conformidad:	
Refer��ncias ��s normas harmonizadas aplic��veis utilizadas, incluindo a data da norma, ou ��s outras especifica��o��es t��cnicas, incluindo a data da especifica��o, em rela��o ��s quais �� declarada a conformidade:	
EN 60745-1:2009+A11:2010	
EN 60745-2-3: 2011+A2:2013 +A11:2014+A12:2014+A13:2015	
EN IEC 55014-1:2021	
EN IEC 55014-2:2021	
EN IEC 61000-3-2:2019+A1:2021	
EN 61000-3-3:2013+A1:2019+A2:2021	

Authorized Signatory and technical file holder/ Signataire et responsable de la documentation technique autorisé/ Podmiot uprawniony do wystawienia i adres przechowywania dokumentacji technicznej/ Semnatar autorizat și deținătorul dosarului ethnic/ Firmante autorizado y titular del expediente técnico/Signatário autorizado e detentor da ficha técnica:

Kingfisher International Products B.V.,
Rapenburgerstraat 175E,
1011 VM Amsterdam,
The Netherlands

A handwritten signature in black ink, appearing to read 'David Awe', with a long horizontal stroke extending to the right.

David Awe
Group Quality Director

28/03/2023

Manufacturer • Fabricant • Producent • Producător • Fabricante:

UK manufacturer:

Kingfisher International Products Limited
3 Sheldon Square London W2 6PX
United Kingdom
www.kingfisher.com/products

EU manufacturer:

Kingfisher International Products B.V.
Rapenburgerstraat 175E
1011 VM Amsterdam
The Netherlands

www.diy.com | www.screwfix.com | www.screwfix.ie

To view instruction manuals online,
visit www.kingfisher.com/products

Customer Helpline:

UK 03301248111 erbauer@powertoolservicing.co.uk

Eire 0035312479977 erbauer@powertoolservicing.co.uk