

AQUALISA®

MATT BLACK ROUND BAR VALVE

INSTALLATION AND USER GUIDE

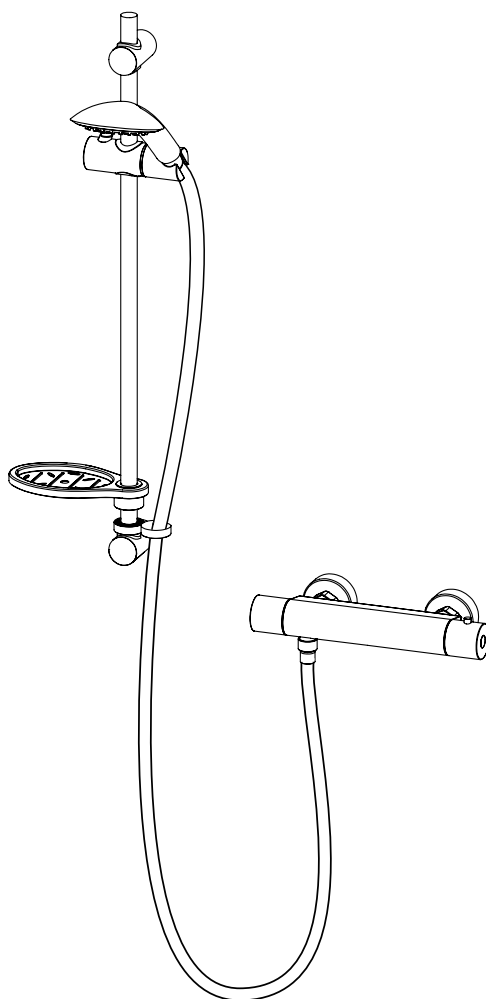

CONTENTS

General Information	2
Tools Required (Tools not supplied)	2
Components	3
Warranty	4
Before You Start	4
Installation	5
Cartridge Temperature Adjustment	9
General Maintenance	10
General Cleaning	12
User Instructions	13
Trouble Shooting	14

GENERAL INFORMATION

This product complies with EN1111.

This product must be fitted in compliance with the UK Water Supply (Fittings) Regulations. If in doubt please contact your local water authority.

TOOLS REQUIRED (TOOLS NOT SUPPLIED)



We have taken great care to ensure that this product reaches you in perfect condition. However should any parts be damaged or missing please contact your point of purchase. This does not affect your statutory rights. In addition if you require replacement parts please contact the Aqualisa customer helpline on 01959 560010 for assistance.

COMPONENTS

	NO.	DESCRIPTION	QTY
	1	Wall Plug	2
	2	Upper Rail Bracket	1
	3	Wall Screw - Short	1
	4	Rail End Cap	2
	5	Handset Holder	1
	6	Soap Dish	1
	7	Hose Restraint	1
	8	Riser Rail	1
	9	Lower Rail Bracket	1
	10	Wall Screw - Long	1
	11	Wall Plug	4
	12	Fixing Bracket	2
	13	Wall Screw	4
	14	Copper Olive	2
	15	Threaded Connector	2
	16	Wall Plate	2
	17	Sealing Washer	2
	18	Bar Valve	1
	19	Shower Hose - 1.5m	1
	20	Handset	1

WARRANTY

Aqualisa products are supplied complete with a 1 year guarantee that can be upgraded by registering this product with Aqualisa.

For details see: www.aqualisa.co.uk/warranty

BEFORE YOU START

This shower should be installed by a competent person in compliance with current Water Supply Regulations. For further details contact your Local Water Authority.

- a. Identify all components and check pack contents.
- b. Turn off water supplies.
- c. Suitable full bore isolation valves must be fitted to both supplies in accordance with current Water Supply Regulations and our terms of warranty. Valves must be accessible for warranty and servicing.



Before making any pipe connections all supplies **MUST** be thoroughly flushed to remove any debris.

WATER SUPPLY REQUIREMENTS

Hot Water Maximum: 65°C

Cold Water Minimum: 5°C

Recommended 60-65°C

Recommended 10-15°C

Always maintain a 10°C difference between hot system temperature and maximum hot setting of valve.

Operating Pressure Range: Min. 0.15 bar, Max. 5.0 bar

When water pressure is higher than 5 bar a pressure reducing valve (not supplied) must be fitted before the mixer. A setting of 3 bar is recommended.

This valve is suitable for gravity stored, gravity boosted, balanced high pressure and combination boiler systems.

For gravity and gravity pumped systems use 22mm supply pipes and reduce to 15mm to protrude through the finished wall.

Pump Installation: PUMPS MUST NOT BE FITTED DIRECTLY TO A WATER MAIN. REFER TO PUMP MANUFACTURERS INSTALLATION GUIDELINES. Ensure there is adequate flow through the pump to activate the flow switches.

Combination boiler: MUST have a minimum rating of 24kW (80,000 Btu) and be of the type fitted with a fully modulating gas valve.

Boiler performance may affect outlet temperature.

Operating pressures: Hot and cold supplies should be kept as even as possible in order to ensure the maximum efficiency of the mixer.

INSTALLATION

Fitting the Bar Valve

1

Ensuring adequate provision to allow the water to discharge safely to waste, turn on the supplies to flush the system through. Attach pressure test equipment and pressure test the system in accordance with Water Supply Regulations.

2

Turn off the water supply following system flushing.

3

Construct suitable 15mm inlet supplies at level 150mm centres. Ensure the pipework protrudes a minimum of 100mm, measured from the intended finished wall surface.

Inlet water supplies

As viewed from front on:

Left = HOT Right = COLD

Pipe centres: 150 ± 1 mm

Pipe tails: 26 - 28mm
From finished surface

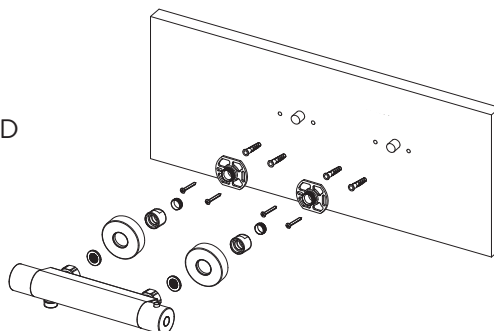

4

Once the wall surface has been finished, flush through the pipe work prior to trimming the length of the pipes to 26-28mm, measured from the finished wall surface.

N.B. We recommend using a rotary type cutter but if a hacksaw is used, ensure the cut is straight and the pipe ends must be carefully deburred and chamfered.

N.B. If plastic pipe is used, tube inserts must be fitted and must not increase the diameter or extend the cut off length by more than 2mm. It may be easier to fit the pipe inserts AFTER fitting the copper olives.

5

Place the fixing bracket over the projecting pipe tails, mark and drill the fixing points taking care to avoid pipe work buried within the wall.

Apply mastic around the pipes where they protrude through the wall.

6

Using the wall plugs and screws provided (if suitable), fit the bracket to the wall.

7

Place the copper olives onto the protruding pipework.

IMPORTANT: The pipework must not protrude past the copper olives by more than 7mm.

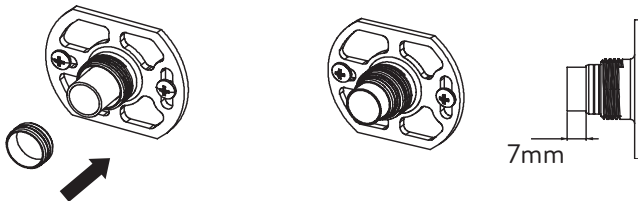

8

Holding the flat edges of the fixing bracket with a large adjustable spanner, screw the threaded connector onto the fixing bracket using a 22mm spanner. Repeat this step on both sides.

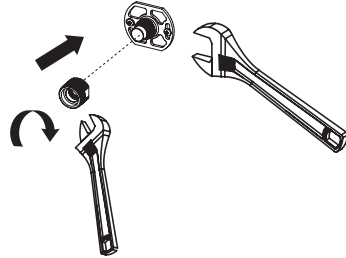

9

Screw the wall plates over the wall bracket/threaded connectors, so they are flush against the finished wall surface.

10

Ensuring the sealing washers are positioned within the valve inlets, offer the bar valve into position. Tighten the fixing nuts using a suitable tool taking care not to overtighten.

11

Turn on water supplies and check for leaks.

Fitting the Shower Kit

1

The top bracket is a floating bracket and can be positioned to suit existing screw holes (if required).

Prepare two fixing points, using the fixings provided (if suitable).

N.B. The maximum distance between fixing points is **615mm**.



2

Fit the hose restraint and soap dish to the rail followed by the handset holder.

N.B. The handset holder button must be depressed whilst fitting. The button must be to the left of the rail, and the holder to the right.

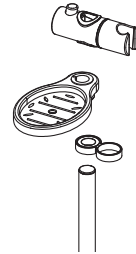

3

Secure the upper rail bracket into position on the finished wall surface using the short wall screw.

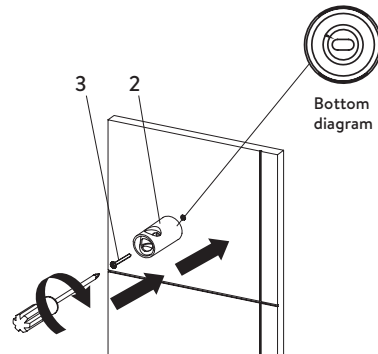

4

Attach the lower rail bracket onto the bottom of the rail.

5

Slide the rail assembly up through the upper rail bracket.

6

Align the small hole in the rail with the lower rail bracket. Secure the lower rail bracket to the wall, using the long wall screw.

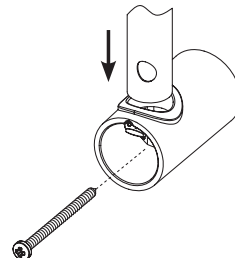

7

Place the rail end caps into the brackets and push firmly into position.

8

Ensuring the hose washer is in position; attach the non-conical end of the hose to the bar valve. Run the shower for a few seconds to clear any debris that may be present.

9

Pass the conical end of the shower hose through the hose restraint.

10

Ensuring the hose washer is in position; attach the conical end of the hose to the shower head, then place the hose in the handset holder.

CARTRIDGE TEMPERATURE ADJUSTMENT

This product has been factory set under balanced pressures, and a hot water supply of 65°C.

N.B. This product can reach temperatures in excess of 50°C.

If site conditions vary significantly from the factory conditions, it may be necessary to reset the temperature of the cartridge to enable the product to deliver 38°C when the temperature knob is set to the 38°C position.

In this case, you can adjust the cartridge to change the outlet water temperature to suit your requirements. This can be adjusted whilst using a digital thermometer and following the below instructions.

1. Turn the temperature knob to the 38°C position.
2. Carefully remove the cap, loosen and remove the screw, then remove the temperature knob.
3. Run the shower at required flow.

4. Whilst measuring the temperature of the water, and without removing the temperature override stop, turn the brass spindle until the temperature reaches 38°C.
5. Once 38°C is achieved, turn the shower off.
6. Refit the temperature knob by depressing the temperature override safety button and carefully pushing the knob into place with the button at the 12 o'clock position. Tighten the screw and fit the cap.

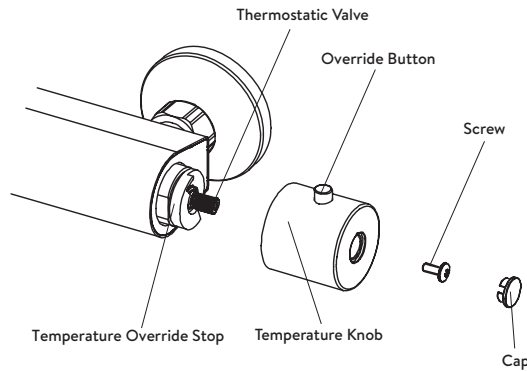

GENERAL MAINTENANCE

Cleaning the thermostatic cartridge

1. Before carrying out any maintenance, ensure the water supplies are isolated. Once isolated, turn the shower on to release internal pressure. If unsure contact a qualified tradesman.
2. Carefully remove the cap (1), loosen and remove the screw (2), then remove the temperature knob (3).
3. Note the position of the temperature override stop and thermostatic cartridge before removal as they must be refitted in the same position. Once noted, remove the temperature override stop (4) from the cartridge. Remove the retaining nut (5) using a suitable spanner, remove and clean the thermostatic cartridge rinsing thoroughly under cold water to remove any build up of limescale or debris.

4. If necessary, replace the cartridge. A replacement cartridge can be obtained by contacting customer service on 01959 560010.
5. Refit the cartridge (6) into the bar valve body, tighten the retaining nut (5) using a suitable spanner and refit the temperature override stop (4).
6. Refit the temperature knob (3) by depressing the temperature override safety button and carefully pushing the knob into place with the button at the 12 o'clock position. Tighten the screw (2) and fit the cap (1).
7. Reinststate the water supply and ensure there are no leaks.

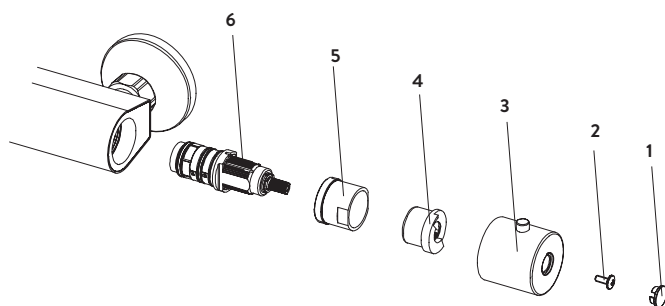

Cleaning the on/off flow headworks (image overleaf)

1. Before carrying out any maintenance, ensure the water supply is isolated. Once isolated, turn the shower on to release internal pressure. If unsure contact a qualified tradesman.
2. Carefully remove the cap (1), loosen and remove the screw (2), then remove the flow control knob (7).
3. Remove the On/Off flow control headworks (8) using a suitable spanner. Clean the On/Off flow control headworks (8) by rinsing thoroughly under cold water to remove any build up of limescale or debris.
4. If necessary, replace the On/Off flow control headworks. A replacement can be obtained by contacting customer service on 01959 560010.
5. Refit the On/Off flow control headworks (8) into the bar valve body and tighten using a suitable spanner.
6. Refit the On/Off flow control knob (7). Tighten the screw (2) and fit the cap (1).
7. Reinststate the water supply and ensure there are no leaks.

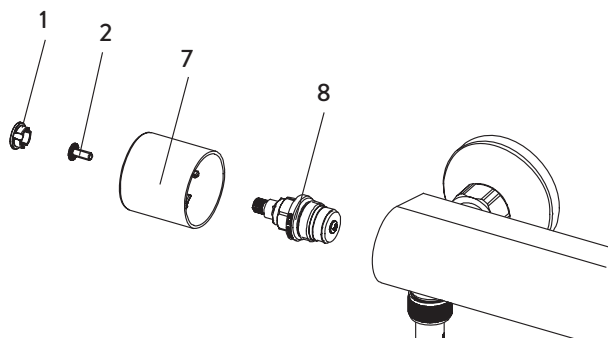

Inlet filters

The product is protected by inlet filter washers. It is suggested that filters are checked by a competent person at least every 12 months.

GENERAL CLEANING

Whilst modern plating techniques are used in the manufacture of these fittings, the plating will wear if not cleaned properly. The safest way to clean your product is to wipe with a soft damp cloth. Stains can be removed using washing up liquid.

DO NOT USE ABRASIVE CLEANERS.

Limescale

Rub the nozzles of the shower head to break down scale build up. Should chemical descaling of the head become necessary, remove the shower head fully and immerse in a mild proprietary descaler.

IT IS IMPERATIVE THAT DESCALING IS CARRIED OUT STRICTLY IN ACCORDANCE WITH THE MANUFACTURERS INSTRUCTIONS. SUBSTANCES THAT ARE NOT SUITABLE FOR PLASTICS AND ELECTROPLATED SURFACES MUST NOT BE USED.

USER INSTRUCTIONS

Shower valve - The bar valve and fixing bracket assembly MUST NOT be used as a grab rail or means of support.

Controls - As viewed from the front: On/Off Flow - Left. Temperature - Right.

Turn the shower on by rotating the left hand side control knob towards the wall until desired flow rate is achieved.

Turn the shower off by rotating in opposite direction until a stop is reached.

The shower is at mid blend position when the button on the right hand knob is centrally at the top.

N.B. The mid blend temperature is dictated by the temperature of the incoming supplies.

To select a comfortable showering temperature, depress the override button and rotate the dial using the temperature markings as a guide.

For cooler temperature - rotate towards the wall.

For warmer temperature - rotate away from the wall.

N.B. With all shower valves fitted to combination boiler systems, it may be necessary to adjust the flow control knob and reduce the flow to achieve a comfortable showering temperature.

Shower head

1. To select the preferred height for the shower head, depress the handset holder button to enable the slider to be moved up or down the rail.
2. Angular adjustment is made by carefully but firmly pulling the shower head forwards, or pushing the shower head back towards the wall.

N.B. The tension of the handset holder can be adjusted with a screwdriver.

3. To select the desired spray pattern rotate the shower spray plate clockwise or anti-clockwise.

NEVER ATTEMPT TO MAKE ANY ADJUSTMENT TO THE SHOWER HEAD BY PULLING ON THE SHOWER HOSE.

TROUBLE SHOOTING

Symptom	Possible Cause	Remedy
No flow or low flow rate and/or varying temperatures.	Check shower head, hose and filters for any blockage.	Clean as necessary. Refer to General Maintenance section (page 10).
	Partially closed stop or service valve in water supply pipework to the shower valve.	Open stop or service valve.
	Instantaneous water heater cycles on and off as the flow rate or pressure is too low.	Increase water flow rate or pressure through system. Contact the boiler manufacturer.
	Head of water is below the minimum distance required.	Raise the cistern or fit a shower booster pump.
	Inlet filter is partially blocked.	Clean or replace, flush through pipework before refitting.
	Hot or cold water being drawn off elsewhere causing pressure changes or instantaneous boiler temperature changes.	Do not use other water outlets when using the shower.
	Make sure the maintained inlet pressures are nominally balanced and sufficient.	Refer to Water Supply Requirements (page 4).
	Airlock or partial blockage of the pipework (gravity supply only).	Flush through pipework to ensure removal of debris and any airlocks.
Only hot or cold water from the shower valve outlet.	No hot or cold water reaching the shower valve.	Check hot and cold feeds (the valve will shut down if either the hot or cold supply fails).
	Partially closed stop or service valve in water supply pipework to the shower valve.	Open stop or service valve.
	Inlet filter is partially blocked.	Clean or replace, flush through pipework before refitting.
Water leaking from shower head.	Inlet water supplies are reversed (hot to cold supply).	Check the connections are the correct way round. Hot on the left and cold on the right when viewed from the front. Rework pipework as necessary.
	This is normal for a short time after turning off.	Adjust angle of shower head in holder as necessary to vary draining time. Clean shower head.
Maximum water temperature too hot or cold.	Shower flow valve failing to close fully, possibly due to water borne debris.	Remove flow valve and check. Refer to Cleaning the On/Off Flow Headworks section (page 11) before dismantling shower valve.
	Maximum water temperature set incorrectly.	Reset maximum water temperature. Refer to Cartridge Temperature Adjustment (page 9).

Symptom	Possible Cause	Remedy
Outlet water temperature too hot/cold.	Inlet filter is partially blocked.	Check inlet filters for any blockages and clean as necessary.
	Installation conditions outside operating parameters.	Refer to Water Supply Requirements (page 4). Refer to Cleaning the Thermostatic Cartridge section (page 10). Refer to Cartridge Temperature Adjustment (page 9).
	Hot water temperature is less than 10°C above the required blend temperature.	Adjust hot water temperature or wait for water to reheat if stored system is used.
	Instantaneous water heater not igniting because water flow rate is too low.	Increase water flow rate through the system. Check inlet filters and clean or replace. Refer to Cleaning the Thermostatic Cartridge section (page 10). Contact the boiler manufacturer.
Handset holder tight/loose.	Requires adjustment.	Use cross head screwdriver in handset holder to adjust.
Control dials stiff to operate.	Debris/Scale build up.	See General Maintenance (pages 10-12).

AQUALISA

Aqualisa Products Limited
The Flyers Way
Westerham Kent TN16 1DE

Customer Helpline: 01959 560010 | Brochure Hotline: 0800 652 3669
Website: www.aqualisa.co.uk | Email: enquiries@aqualisa.co.uk
Warranty: www.aqualisa.co.uk/warranty

Republic of Ireland
Sales enquiries: 01-864-3363
Service enquiries: 01-844-3212



Please note that calls may be recorded for training and quality purposes.

The company reserves the right to alter, change or modify the product specifications without prior warning.

™ Trademark of Aqualisa Products Limited.



Drawing No: 707572 Issue 01 May 23