

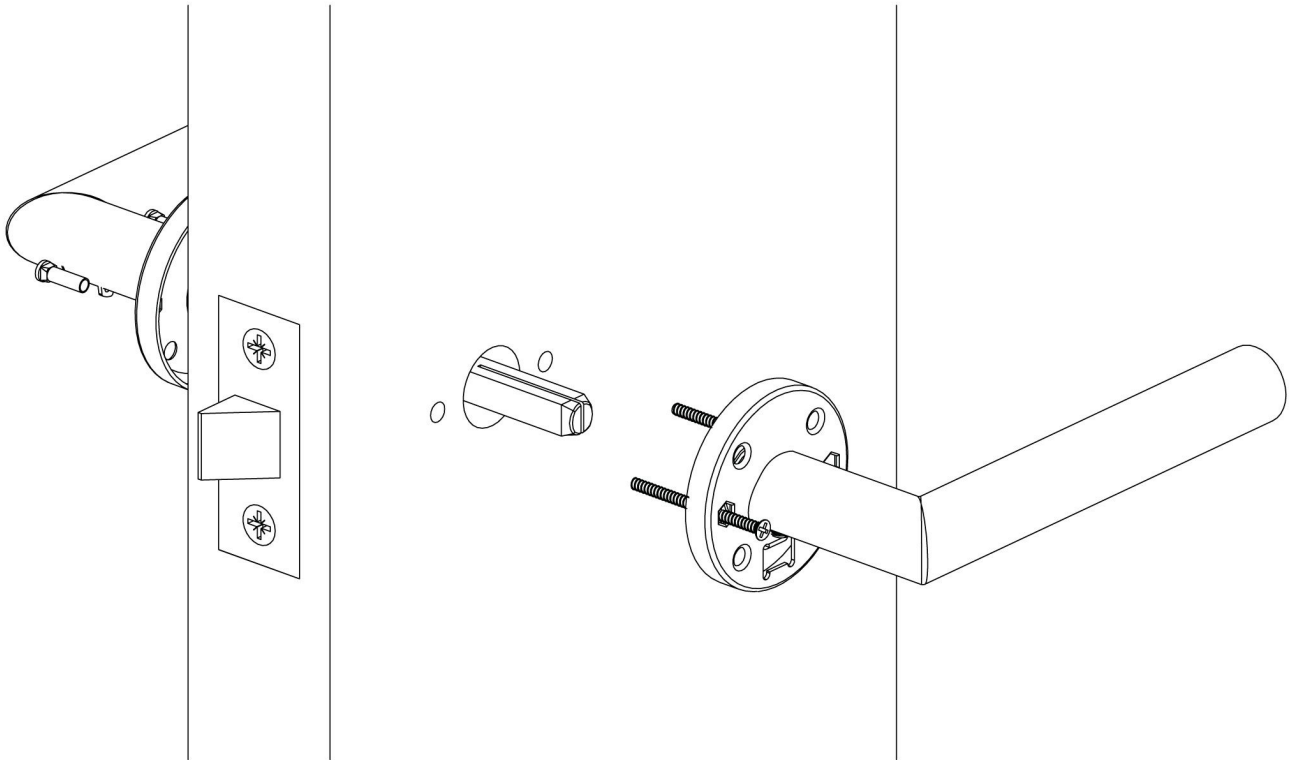

Note: Misalignment of any single component can lead to the breakdown of complete door set operation. Never drill any holes whilst the latch is inserted in the door. It is recommended to pilot drill all fixings prior to final fitting to prevent excess strain on the fixings.

Lever Installation:



1. Insert the Spindle into the Lever with Male Bolts in situ and securely fix the Grub Screw, ensuring enough Spindle is free to pass through the Door and to be secured in the opposing Lever.
2. Place the Lever onto the Door so the Spindle passes through the Latch Follower and line up the holes on the rose with those pre-drilled in the Door.
3. Place the second Lever onto the opposite side of the Door, use both Bolts and evenly hand tighten so each lever is secured firmly against the surface of the door.
4. Tighten up the grub screw on the opposite lever and check all fixings are secure. If the levers do not operate freely, check alignment of all components.
5. Secure Inner Rose with provided Wood Screws.
6. Place and screw on both outer rose covers.



Note: Misalignment of any single component can lead to the breakdown of complete door set operation. Never drill any holes whilst the latch is inserted in the door. It is recommended to pilot drill all fixings prior to final fitting to prevent excess strain on the fixings.

Latch Installation:

- Using a pencil, mark the door edge for the height and width of the Mortice, and also for the forend.
- Mortice the hole width and depth according to the size of the latch body, ensuring any shavings or swarf are removed and the Mortice is smooth.
- Insert Latch body into Mortice and draw around the Faceplate. Chisel out to the required depth (Including both Forend and Faceplate). Remove the Latch from the Mortice
- Mark out Centre Hole A, then fixing holes B1 and B2 at 38mm centres using the Latch body as a guide. Ensure Faceplate is flush with Door edge when measuring the Backset.
- Using a 20mm diameter drillbit, drill hole A at the marked location for the spindle. Use a 5mm diameter drillbit and drill holes for the bolt-through fixings B1 and B2 at 38mm centres as shown.
- Insert the Latch (noting direction of operation) and Loose Faceplate into the Mortice. Fix in place with included screws.
- Check operation of Latch prior to preparing the frame for the Strike Plate by inserting the Spindle and turning.
- With the Latch fitted close the Door to the Frame and mark the top and bottom edge of the Latch on the outer of the Door Frame.
- Transfer these two marks across to the inside of the Door Frame rebate. Mark an additional horizontal line approximately 2mm above the top line. This line represents the top inside edge of the aperture within the Strike Plate and will provide operating clearance.
- Identify where the resting position of the Latch will be, and draw around the Strike Plate accordingly.
- Chisel out the frame to accommodate the Strike Plate and Dustbox accordingly. Ensuring that when fitted, the Strike Plate and Dust Box are flush with the Frame.
- Close Door to check proper operation. Adjust anti-rattle tabs as necessary.

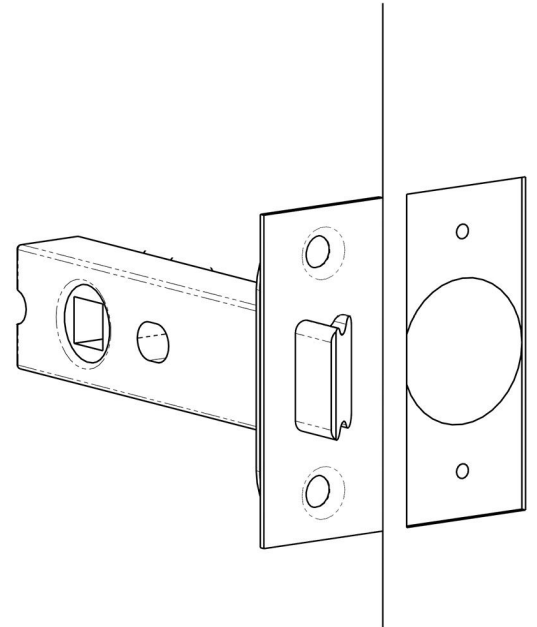

Bolt-Through Drilling

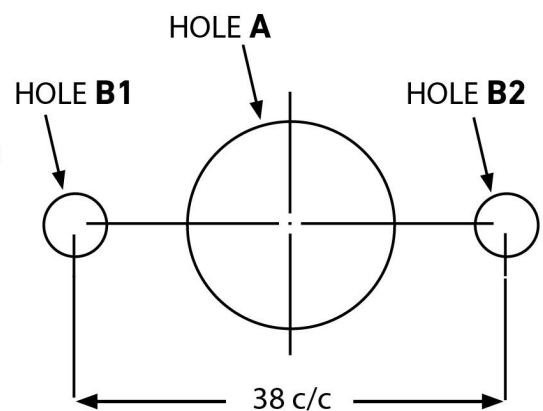



Note: Read through the instructions carefully, and ensure you have the appropriate tools and assistance. If you are unsure please contact a professional. Drawings not to scale unless otherwise specified. Incorrectly installing this product will negatively impact function and lifespan.

Selecting Correct Hinge Spacing:

Figure 1 - The standard practice, equally spacing hinges prevents “warping”.

Figure 2 - Used where overhead door closers are fitted, offsets additional lateral forces on the top hinges.

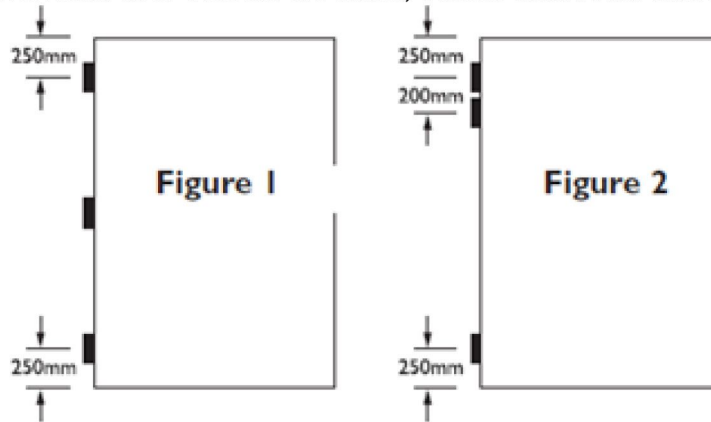

1. At the determined spacing, Position the Door side of the Hinge (The Hinge Leaf with the inner knuckle sections) to the Door so that the edges are Flush, and mark around Leaf. Repeat at each Hinge Position.
2. Mortice out Door to equal the thickness of the Hinge Leaf. The mortice should be smooth and any shavings or swarf must be removed.
3. Position Leaf into Mortice, mark the fixing holes, and pilot drill holes for the fixing screws.
4. Secure the Hinge Leaf to the Door using the screws provided, and repeat for other Hinges on the Door.
5. Offer the Door up to the Frame. Pack under the Door Leaf to required clearance. Once in required position, open the top Hinge Leaf flat against the Frame so that the knuckle crank line is slightly proud of the edge and mark around the Frame side of the Hinge Leaf.
6. Repeat at each Hinge Position.
7. Mortice out the markings on the Door Frame to equal the thickness of the Hinge Leaf as (Step 2).
8. Position Leaf into Mortice, Pilot drill fixing holes, secure Hinge with screws provided, and repeat for remaining Hinges.

