

Instructions for use  
—Type 1 Flush Fix



## Type 1 flush button-fix

The Button-fix concept is simple: durable Fixes are attached to the back of one panel and the mating Buttons are attached to the other. Bring the panels together and slide until the Button-fixes 'click'.

The Type 1 Flush Button-fix is moulded in glass-reinforced nylon. It is designed for applications where panel-panel contact is required and fits a simple oval rebate. It can be rebated into the edge of a panel of at least 28mm thick or the face of a panel of at least 18mm thick, and orientated for vertical or sideways assembly.

Visit the website for more information on the complete Button-fix range, including videos of Button-fix in use. You can also obtain a new copy

of these instructions from the website in the event of loss or in the event that Buttonfix modifies the instructions.

Buttonfix Limited retains the right to modify the instructions as it deems appropriate and the consumer is responsible for checking the website for the latest information.

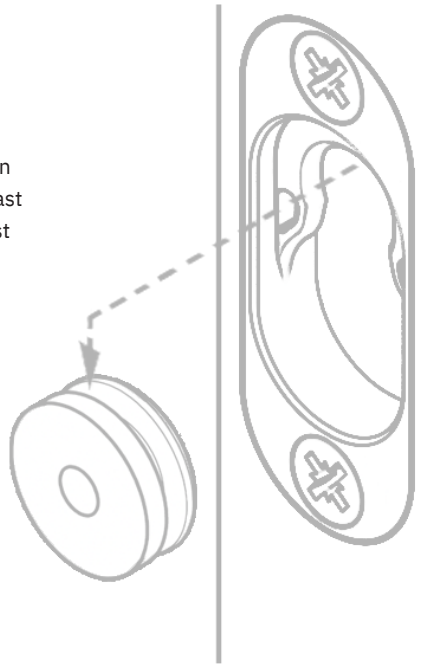

## Warnings

—Button-fix is intended for furniture construction and interior fittings and is not intended, nor should it be used, for any other purpose.

—**WARNING:** Serious damage to property and severe bodily injury can result from (1) improper use, application or installation of the Button-fix or (2) use as part of improperly designed or constructed assemblies or materials.

—Provided that the screws and substrate are properly matched, and all other instructions complied with, tests showed that a vertical panel fixed with four Type1 Flush Fixes can support loads weighing up to a maximum of 100kg (220lbs). For critical applications it is essential to perform your own tests.

—Avoid any contact with aggressive solvents and cleaning products.

—It is not possible for Buttonfix to warn the consumer about every possible danger related to use of the Button-fix and the consumer must use his or her own good judgment when installing and using the Button-fix.

## The button

There are two Buttons to suit different screw types. These are colour-coded lime green for Ø5mm countersunk wood screws, or orange for Ø6.2mm Varianta Euro screws (to fit Ø5mm pilot holes).

Check with your panel supplier which screw type is best for your application.

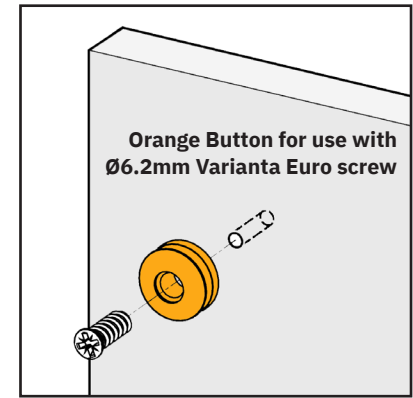
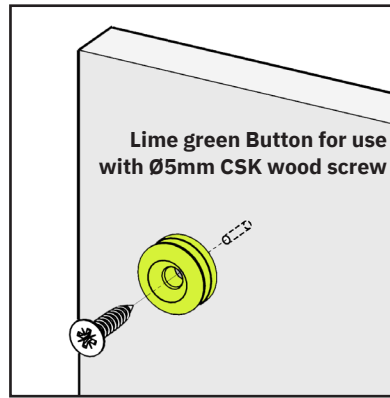

## Button marker accessory

The Button marker accessory helps to mark out where to install the Buttons.

Once you have attached the Fix mouldings (see following pages), insert a marker into each one. Then position the second panel and press firmly. The markers will leave indents in the panel surface, which can be used as guides for drilling pilot holes for the Buttons.

Remove the markers, which can be re-used to mark out the next panel.

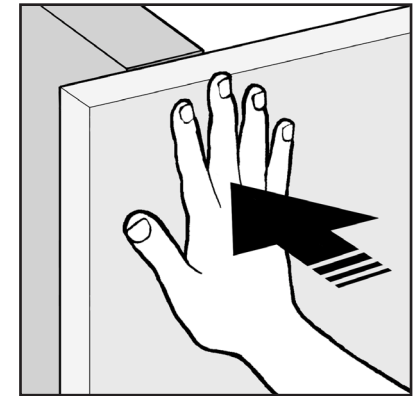
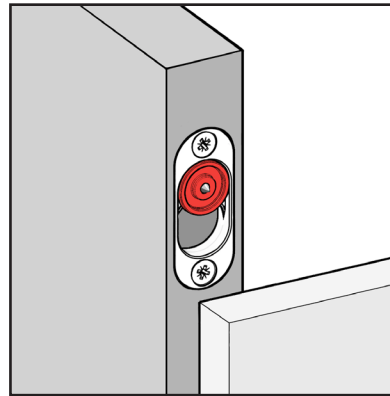

## Rebated fix

### 1. Edge-rebated fix

The Type 1 Flush Fix may be rebated into the edge of a panel of at least 28mm thickness. An oval rebate measuring 22 x 56 x 8.1mm is required.

**Ensure the 8.1mm depth of the cutter is accurately set on the router.**

2 x Ø4.5mm countersunk wood screws at least 25mm long are required.

The Fix may be installed either way up depending on the application.

### 2. Face-rebated fix

The Fix may be rebated into the face of a panel of at least 18mm thickness.

An oval rebate measuring 22 x 56 x 8.1mm is required. As above, the accuracy of the 8.1mm depth of the rebate is highly important.

The Fix may be installed either way up, or orientated horizontally or vertically, depending on the application.

## Surface-mounted fix

In some circumstances you may chose not to rebate the Fix. This creates an 8mm gap between the panels.

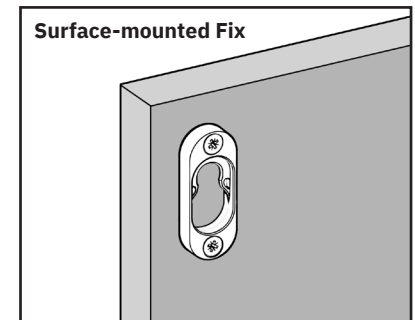
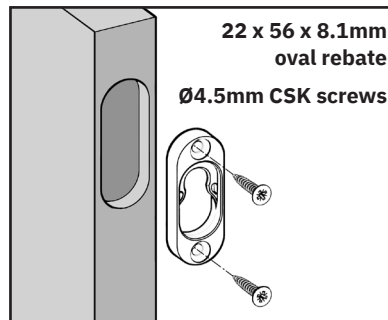
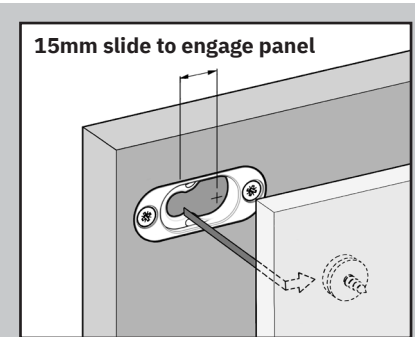
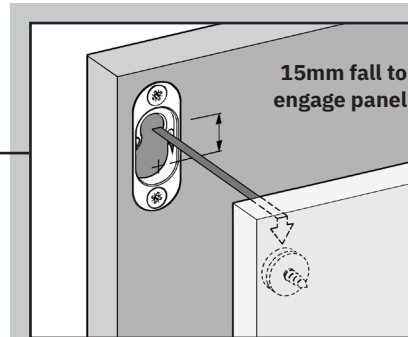
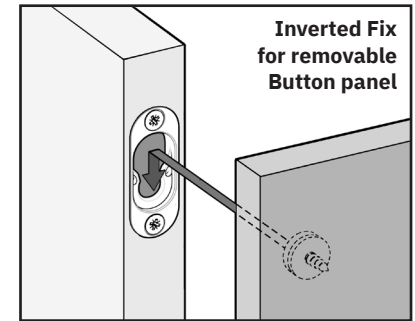
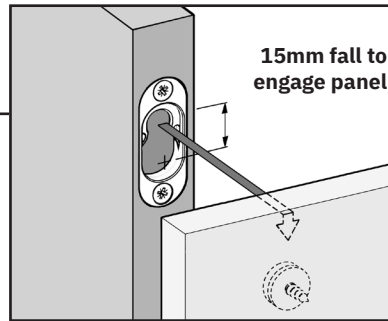

## A useful tip

When several Button-fixes are used on a panel, or if you require the panel to be easily removable, first try spraying the fixes with a PTFE or Silicone based lubricant spray.

The strength of the click-fit can be further reduced by adapting some (but not all) the Fix mouldings by snapping off the ears with needle-nosed pliers, as shown in the diagram on the right.

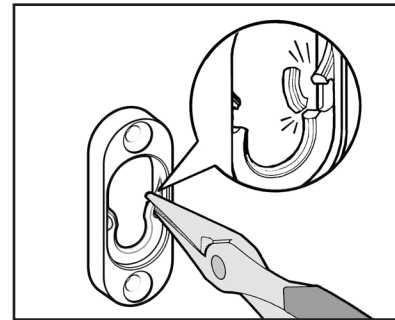

## Suggested layout

As an approximate guide, we suggest that Button-fix centres are no greater than 600mm apart and no closer than 14mm to the edge of the panel.

A Fix may also be rebated into the edge of a panel with a minimum thickness of 28mm.

Always remember to allow at least 15mm clearance for the removable panel to disengage.

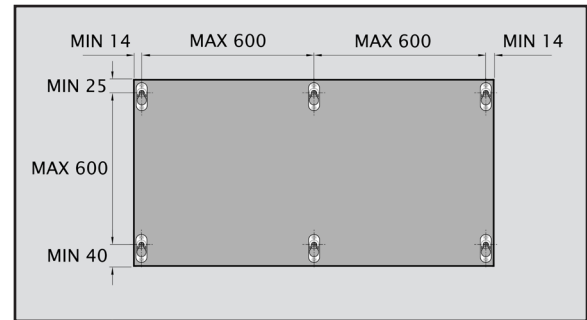

## Router jig accessory

A router jig can be ordered separately for accurately machining the rebates for the Fixes, described on the previous page.

The jig is designed for use with a metric 12mm cutter and 16mm guide bush. Read the separate instructions supplied with the accessory before use.

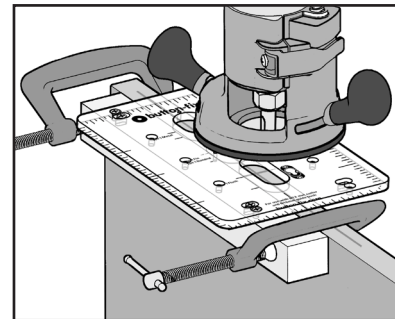

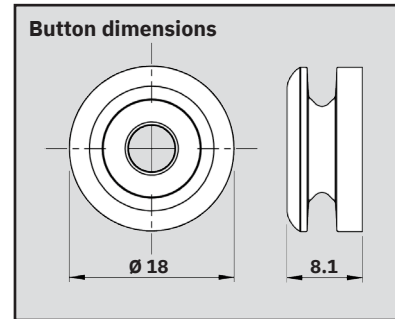
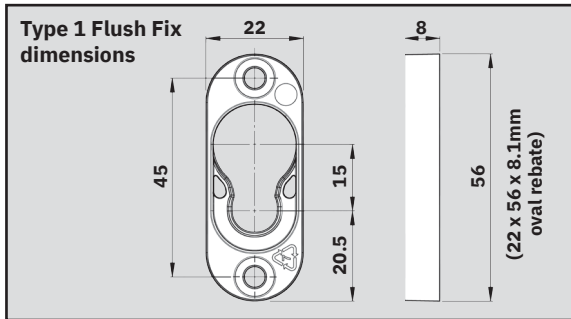

**Manufactured in the UK**

**Buttonfix Limited  
Unit A, 1 Britton Street  
London, EC1M 5NW**

**T: +44 (0)20 8150 7190**

**E: [info@button-fix.com](mailto:info@button-fix.com)**

**[button-fix.com](http://button-fix.com)**

