

# TITAN

## Lawnmower 18V 34cm

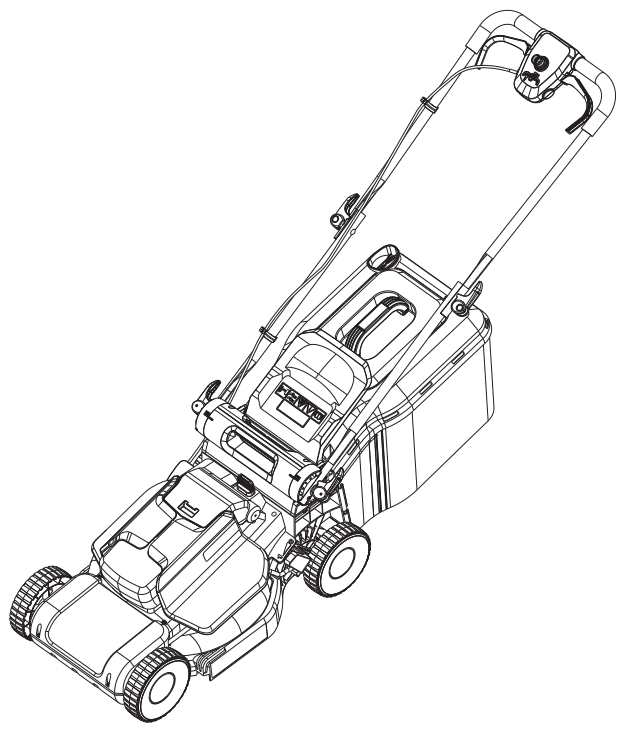

# TTI836LWM



WARNING: Read the instructions before using the product!

# Let's get started...

These instructions are for your safety. Please read through them thoroughly before use and retain them for future reference.



## Getting **started...** 02

<b>Safety</b> information	03
<b>Your</b> product	14
<b>Before</b> you start	15



## **In more detail...** 22

<b>Product</b> functions	23
<b>Operation</b>	27
<b>Care</b> and <b>maintenance</b>	29
<b>Troubleshooting</b>	33
<b>Recycling</b> and <b>disposal</b>	34
<b>Guarantee</b>	35
<b>Technical</b> specifications	37
<b>Declaration</b> of <b>conformity</b>	39

## Safety warnings

1. This product is not intended for use by persons (including children) with reduced physical, sensory or mental capabilities, or lack of experience and knowledge, unless they have been given supervision or instruction concerning use of the product by a person responsible for their safety.
2. Local regulations may restrict the age of the operator.
3. Children should be supervised to ensure that they do not play with the product.
4. Cleaning and user maintenance shall not be made by children without supervision.

### Electrically powered lawn mower safety warnings



**IMPORTANT:** Read carefully before use.  
Keep for future reference.



**WARNING!** When using the product the safety rules must be followed. For your own safety and that of bystanders please read these instructions before operating the product. Please keep the instructions safe for later use.

### Training

1. Read the instructions carefully. Be familiar with the controls and the proper use of the product.
2. Never allow children, persons with reduced physical, sensory or mental capabilities or lack of experience and knowledge or people unfamiliar with these instructions to use the product. Local regulations may restrict the age of the operator.

## Safety warnings

---

3. Never mow while people, especially children, or pets are nearby.
4. Keep in mind that the operator or user is responsible for accidents or hazards occurring to other people or their property.

### Preparation

1. While mowing, always wear substantial footwear and long trousers. Do not operate the product when barefoot or wearing open sandals. Avoid wearing clothing that is loose fitting or that has hanging cords or ties.
2. Thoroughly inspect the area where the product is to be used and remove all objects which can be thrown by the product.
3. Before using, always visually inspect to see that the cutting blade, cutting blade bolts and cutting blade assembly are not worn or damaged. Replace worn or damaged cutting blades and bolts in sets to preserve balance. Replace damaged or unreadable labels.
4. CAUTION! Do not touch a rotating cutting blade.

### Operation

1. Operate the product only in daylight or in good artificial light.
2. Avoid operating the product in wet grass, where feasible.
3. Always be sure of your footing on slopes.
4. Walk, never run.
5. Mow across the face of slopes, never up and down.
6. Exercise extreme caution when changing direction on slopes.
7. Do not mow excessively steep slopes.
8. Use extreme caution when reversing or pulling the product towards you.

9. Stop the cutting blade(s) if the product has to be tilted for transportation when crossing surfaces other than grass, and when transporting the product to and from the area to be mowed.
10. Never operate the product with defective guards or shields, or without safety devices, for example deflectors and/or grass catchers, in place.
11. Start the product or switch on the product carefully according to instructions and with feet well away from the cutting blade(s).
12. Do not tilt the product when switching on the motor, except if the product has to be tilted for starting. In this case, do not tilt it more than absolutely necessary and lift only the part, which is away from the operator.
13. Do not start the product when standing in front of the discharge chute.
14. Do not put hands or feet near or under rotating parts. Keep clear of the discharge opening at all times.
15. Do not transport the product while the power source is running.
16. Never pick up or carry the product while the safety key (10) is inserted.
17. Stop the machine, and remove the disabling device. Make sure that all moving parts have come to a complete stop
  - whenever you leave the product,
  - before clearing blockages or unclogging chute,
  - before checking, cleaning or working on the product,
  - after striking a foreign object. Inspect the product for damage and make repairs before restarting and operating the product;

## Safety warnings

---

18. If the product starts to vibrate abnormally (check immediately)
- inspect for damage,
  - replace or repair any damaged parts,
  - check for and tighten any loose parts.

### **Maintenance and storage**

1. Disconnect the product from the power supply (i.e. remove the battery pack and / or safety key) before checking, cleaning or working on the product and when it is not in use.
2. Disconnect the product from the power supply (i.e. remove the battery pack and / or safety key) before carrying out maintenance or cleaning work.
3. Improper maintenance will lead to malfunction/failure of the product.
4. Inspect and maintain the product regularly. Keep all nuts, bolts and screws tight to be sure the product is in safe working condition.
5. Check the grass catcher frequently for wear or deterioration.
6. Be careful during adjustment of the product to prevent entrapment of the fingers between moving blades and fixed parts of the product.
7. Always allow the product to cool before storing.
8. When servicing the blades be aware that, even though the power source is switched off, the blades can still be moved.
9. Replace worn or damaged parts for safety. Use only genuine replacement parts and accessories.
10. Wear strong work gloves when removing and reassembling the cutting blade.

11. Have the product repaired only by an authorised service centre or similar qualified specialist.
12. When not in use, store the product out of the reach of children.

### **Safety warnings for battery pack**

1. **Recharge the battery pack only with the charger specified by the manufacturer.** *A charger that is suitable for one type of battery pack may create a risk of fire when used with another battery pack.*
2. **Use the product only with specifically designated battery pack.** *Use of any other battery packs may create a risk of injury and fire.*
3. **When battery pack is not in use, keep it away from other metal objects, like paper clips, coins, keys, nails, screws or other small metal objects that can make a connection from one terminal to another.** *Shorting the battery terminals together may cause burns or a fire.*
4. **Under abusive conditions, liquid may be ejected from the battery pack; avoid contact. If contact accidentally occurs, flush with water. If liquid contacts eyes, additionally see medical help.** *Liquid ejected from the battery may cause irritation or burns.*
5. **Do not use battery pack that is damaged or modified.** *Damaged or modified batteries may exhibit unpredictable behaviour resulting in fire, explosion or risk of injury.*
6. **Do not expose a battery pack or tool to fire or excessive temperature.** *Continuous intense sunlight, fire or other heat sources may cause an increased danger of explosion.*
7. **Batteries can explode in the presence of a source of ignition, such as a pilot light.** *To reduce the risk of*

## Safety warnings

---

*serious personal injury, never use any cordless product in the presence of an open flame. An exploded battery can propel debris and chemicals. If exposed, flush with water immediately.*

8. **Follow all charging instructions and do not charge the battery pack outside the temperature range specified in the instructions.** *Charging improperly or at temperatures outside the specified range may damage the battery and increase the risk of fire.*
9. **Do not charge battery in a damp or wet location.** *Following this rule will reduce the risk of electric shock.*
10. **Longer life and better performance can be obtained if the battery is charged when the air temperature is between 18°C and 24°C.** *Do not charge the battery in air temperature below 5°C or above 40°C. This is important as it can prevent serious damage to the battery.*
11. **Remove the battery pack from the product when not in use.**
12. **Don't maintain the battery pack on the charger when not in use.**
13. **After extended periods of storage, it may be necessary to charge and discharge the battery pack several times to obtain the maximum performance.**
14. **Do not disassemble the battery and avoid mechanical damage to the battery.** *Risk of short circuit and fumes may be emitted. Ensure fresh air and seek medical assistance in the event of discomfort.*
15. **Never service damaged battery packs.** *Service of battery packs should only be performed by the manufacturer or authorized service providers.*



16. **When disposing of battery pack, keep the battery pack of different electrochemical systems separate from each other.**

### **Vibration and noise reduction**

**To reduce the impact of noise and vibration emission, limit the time of operation, use low-vibration and low-noise operating modes as well as wear personal protective equipment.**

Take the following points into account to minimise the vibration and noise exposure risks:

1. Only use the product as intended by its design and these instructions.
2. Ensure that the product is in good condition and well maintained.
3. Use correct cutting attachments for the product and ensure they are in good condition.
4. Keep tight grip on the handles/grip surface.
5. Maintain this product in accordance with these instructions and keep it well lubricated (where appropriate).
6. Plan your work schedule to spread any high vibration tool use across a longer period of time.

### **Emergency**

**Familiarise yourself with the use of this product by means of this instruction manual. Memorise the safety directions and follow them to the letter. This will help to prevent risks and hazards.**

1. **Always be alert when using this product, so that you can recognise and handle risks early. *Fast intervention can prevent serious injury and damage to property.***

## Safety warnings

2. **Switch the product off and remove the battery pack if there are malfunctions.** *Have the product checked by a qualified professional and repaired, if necessary, before you operate it again.*

### Residual risks

**Even if you are operating this product in accordance with all the safety requirements, potential risks of injury and damage remain. The following dangers can arise in connection with the structure and design of this product:**



1. Health defects resulting from vibration emission if the product is being used over long periods of time or not adequately managed and properly maintained.
2. Injuries and damage to property due to broken attachments or the sudden impact of hidden objects during use.
3. Danger of injury and property damage caused by flying objects.



**WARNING!** This product produces an electromagnetic field during operation! This field may under some circumstances interfere with active or passive medical implants! To reduce the risk of serious or fatal injury, we recommend persons with medical implants to consult their doctor and the medical implant manufacturer before operating this product!

## Symbols

On the product, the rating label and within these instructions you will find among others the following symbols and abbreviations. Familiarise yourself with them to reduce hazards like personal injuries and damage to property.

V	Volt, (direct current voltage)	mA	Milliampere per hour
/min or min <sup>-1</sup>	Per minute	°C	Degree Celsius
g	Gram	kg	Kilogram
mm	Millimetre	m	Metre
cm	Centimeter	l	Litre
dB(A)	Decibel (A-rated)	m/s <sup>2</sup>	Metres per second squared
	Lock / to tighten or secure.		Unlock / to loosen.



Read the instruction manual.



Note / Remark.



Caution / Warning.

IPX4 Protection against solid foreign bodies as well as against splashed water from all directions.

xxWyy Manufacturing date code; year of manufacturing (20xx) and week of manufacturing (Wyy)



Wear hearing protection.



Wear eye protection.



Wear a dust mask.



Wear protective gloves.



Wear protective, slip-resistant footwear.



Wear tight-fitted protective clothes.



Switch the product off and remove battery pack before assembly, cleaning, adjustments, maintenance, storage and transportation.



This product is of protection class III.



Mow across the face of slopes, never up and down.

## Symbols



Inspect the area where the product is to be used and remove all objects which can be thrown by the product. If objects are hidden while operating stop the motor and remove the object.



Objects thrown by the product could hit the user or other bystanders. Always ensure that other people and pets remain at a safe distance from the product when it is in operation. In general, children must not come near the area where the product is.



Cutting blade continues to rotate after the product is switched off. Wait until all machine components have completely stopped before touching the product.



Pay special attention when working on the cutting blade!



Beware of sharp blades. Blades continue to rotate after the motor is switched off - Remove disabling device before maintenance. Keep hands and feet away from sharp rotating parts – danger of injury! When cleaning, repairing, or inspecting, make certain the cutting blade and all mowing parts have stopped.



Grass catcher is ready for grass collection.



Grass catcher is full, empty it.



Guaranteed sound power level value in 88 dB.



WEEE symbol. Waste electrical products should not be disposed of with household waste. Please recycle where facilities exist. Check with your Local Authority or local store for recycling advice.



Crossed out dust bin. Batteries and battery packs should not be disposed of with household waste. Please recycle where facilities exist. Check with your Local Authority or local store for recycling advice.



Do not dispose of battery packs in rivers or immerse in water.



Do not dispose of battery packs in fire. They will explode and cause injury.



Do not expose battery packs to heat in excess of 40 °C.  
Do not charge or store the battery pack in temperatures below 5 °C (41 °F) and above 40 °C (104°F).



The product complies with the applicable European directives and an evaluation method of conformity for these directives was done.

UK Conformity Assessed.

## Your product

Getting started...

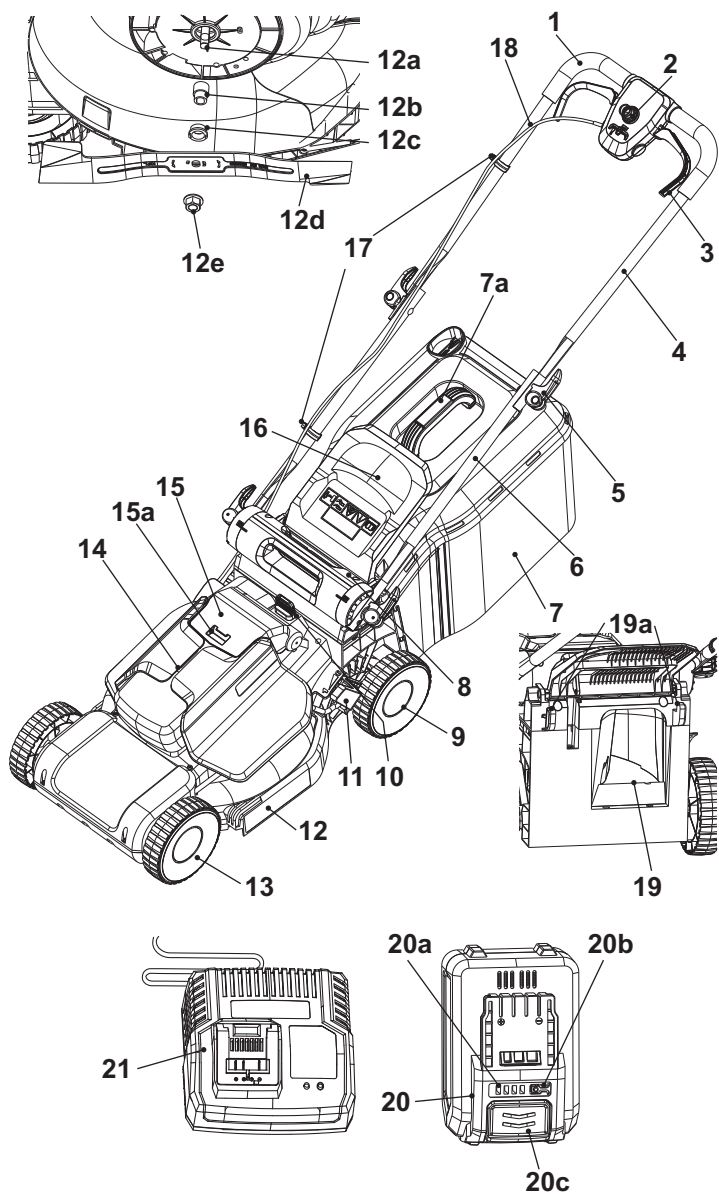

- |                          |   |                                |
|--------------------------|---|--------------------------------|
| 1. Grip handle           | 8. Transport handle                     | c. Slot*                       |
| 2. Safety switch button  | a. indicator*                           | 16. Deflector guard            |
| 3. Start lever (x2)      | 9. Rear wheel (x2)                      | 17. Wire clip (x2)             |
| 4. Upper handle bar      | 10. Safety key                          | 18. Inter-connection cord      |
| 5. Clamp lever (x4)      | 11. Lever for cutting height adjustment | 19. Rear discharge chute       |
| a. Washer*               | 12. Cutting blade compartment           | a. Hook (x2)                   |
| b. Mounting bolt*        | a. Spindle                              | 20. Battery pack               |
| 6. Lower handle bar      | b. Bushing                              | a. Battery capacity indicators |
| a. Indication line (x3)* | c. Flange                               | b. Battery capacity button     |
| 7. Grass catcher         | d. Cutting blade                        | c. Release button              |
| a. Carry handle          | e. Hex nut                              | 21. Charger                    |
| b. Top cover*            | 13. Front wheel (x2)                    |                                |
| c. Rubber clip (x3)*     | 14. Motor housing                       |                                |
| d. Supporting rod*       | 15. Battery cover                       |                                |
| e. Hatch*                | a. Groove                               |                                |
| f. Screw*                | b. Electrical contacts*                 |                                |
| g. Flat washer*          |   |                                |



**NOTE:** Parts marked with \* are not shown in this overview. Please refer to the respective part in the instruction manual.

## Unpacking

1. Unpack all parts and lay them on a flat, stable surface.
2. Remove all packing materials and shipping devices if applicable.
3. Make sure the delivery contents are complete and free of any damage. If you find that parts are missing or show damage do not use the product but contact your dealer. Using an incomplete or damaged product represents a hazard to people and property.
4. Ensure that you have all the accessories and tools needed for assembly and operation. This also includes suitable personal protective equipment.



**WARNING!** The product and the packaging are not children's toys! Children must not play with plastic bags, sheets and small parts! There is a danger of choking and suffocation!

## You will need

(items not supplied)

Suitable personal protective equipment  
Suitable wrench

(items supplied)

Grass catcher (7)  
Cutting blade (12d)  
Battery pack (20)  
Charger (21) and its manual



**NOTE:** The accessories required depend on the intended application. Ask your dealer for advice.

## Assembly



**WARNING!** The product must be fully assembled before operation! Do not use a product that is only partly assembled or assembled with damaged parts!



Follow the assembly instructions step-by-step and use the pictures provided as a visual guide to easily assemble the product! Do not connect the product to battery pack (20) before it is completely assembled!



**NOTE:** Take care of small parts that are removed during assembly or when making adjustments. Keep them secure to avoid loss.

### Handle assembly

The lower handle bars (6) are pre-installed on the transport handle (8).



1. Unfold and loosen the clamp levers (5) anti-clockwise on the lower handle bars (6), but do not remove them (Fig.1, step 1).
2. Grasp the lower handle bars (6) and unfold them from storage position to work position (Fig. 1, step 2).
3. Secure the lower handle bars (6) by folding up the clamp levers (5) towards the lower handle bars (6). If the clamp lever (5) cannot be folded, loosen it and fold again. If it is too loose, tighten it by turning the clamp lever (5) clockwise (Fig. 2).

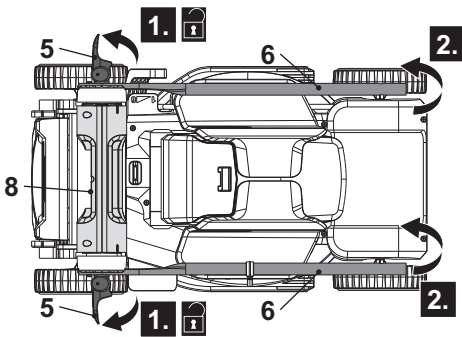

Fig. 1

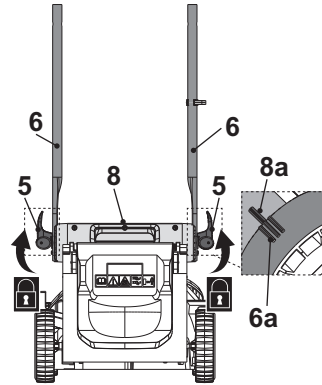

Fig. 2



**NOTE:** For first assembly, secure the lower handle bars (6) with the clamp levers (5) in the middle position of the tilt adjustment mechanism by aligning the indication line (6a) with the indicator (8a) of the transport handle (8). Ensure the lower handle bars (6) are assembled on the same height level on both side.

4. Hold the upper handle bar (4) with the safety switch button (2) facing upwards. Align the mounting holes of the upper handle bar (4) and the lower handle bars (6) (Fig. 3, step 1).
5. Pass the mounting bolt (5b) through the mounting holes to the end (Fig. 3, step 2).
6. Attach the washer (5a) and screw in the clamp lever (5) clockwise through the thread of the mounting bolt (5b), lock it by folding up the clamp lever (5) towards the handle. If clamp lever (5) cannot be folded, loosen it and fold again. If it is too loose, tighten it by swinging the clamp lever (5) (Fig.2, step 3).
7. Do it again on the other side. Make sure that the interconnection cord (18) run on the upper side of the handle bars (4, 6).



**NOTE:** There are two handle height positions in the upper handle bar (4). Ensure the upper handle bar (4) is assembled on the same height level on both lower handle bars (5).

## Assembly

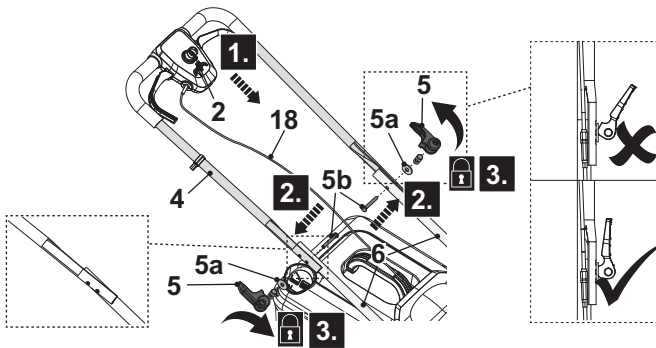

Fig. 3

- Secure the inter-connection cord (18) with two wire clips (17) (Fig. 3). Pull the inter-connection cord (18) to avoid contact with the rear wheel (9) if necessary.

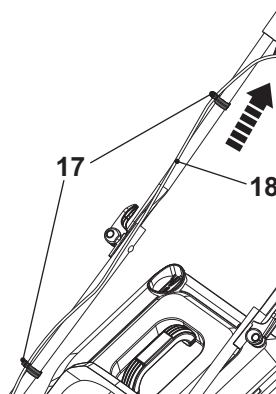

Fig. 4



**WARNING!** Make sure the clamp levers (5) are properly tightened before using the product.

### Grass catcher

- Clip the three rubber clips (7c) to the supporting rod (7d) of the grass catcher (7) (Fig. 5).
- The carry handle (7a) is already preassembled on the top cover (7b) and its position is rotatable to fit the intended use (Fig. 6).
- The grass catcher (7) is ready for use.



**WARNING!** Do not attempt to use the product without the grass catcher attached – danger of flying objects! The motor must be switched off and the blade must have stopped rotating before you remove the grass catcher. The grass catcher must be fully assembled with the top part, bottom part and collection tongue all in position before first use.

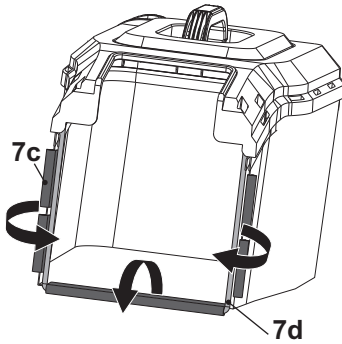

Fig. 5

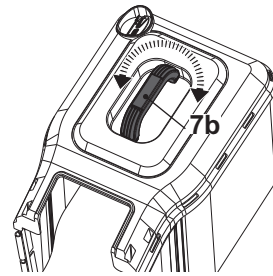

Fig. 6

4. Open the deflector guard (16) and hold it in position (Fig. 7, step 1).
5. Carry the grass catcher (7) by its carry handle (7a).
6. Align the support with the hooks (19a) and hang the grass catcher onto it (Fig. 7, step 2).
7. Carefully release the deflector guard (16) afterwards.

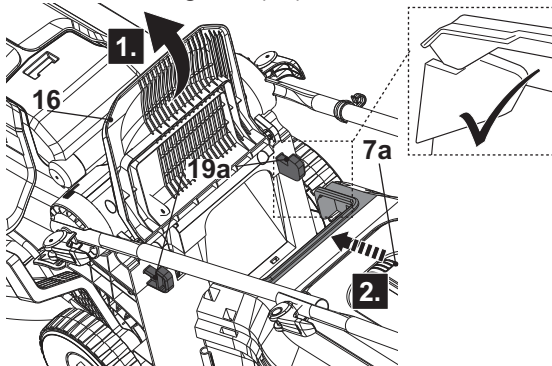

Fig. 7

**NOTE:**

Always carry the grass catcher (7) by its handle (7a).

## Battery pack

### Attaching the battery pack

1. Remove the safety key (10) and keep it avoid loss (Fig. 8, step 1).
2. Hold the groove (15a) and open the battery cover (15) (Fig. 8, step 2).
3. Slide the battery pack (20) into the slot (15c) (Fig. 9, step 1).
4. Make sure that the electrical contacts (15b) are fully inserted into the battery pack and that it snaps in place with a click.
5. The battery pack (20) can only be installed in one direction.
6. Close the battery cover (15).
7. Reinstall safety key (10) to its slot (Fig. 9, step 2).

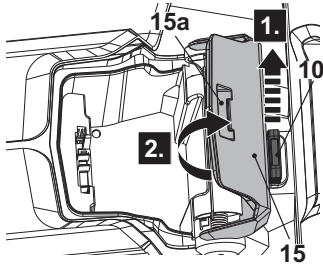

Fig. 8

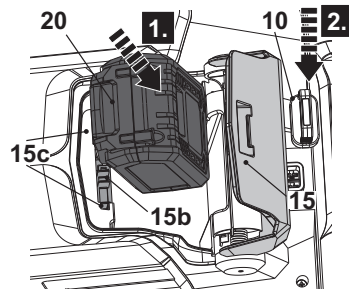

Fig. 9

### Releasing the battery pack

The battery pack (20) can't be charged whilst in the mower. Remove the battery pack (20) from its battery compartment for charging.

1. Hold the groove (15a) and open the battery cover (15) (Fig. 10, step 1).
2. Press down the release button (20c) to unlock the latch of battery pack (20) (Fig. 10, step 2).
3. Slide out the battery pack (20) from the battery compartment (Fig. 10, step 3).
4. Close the battery cover (15).

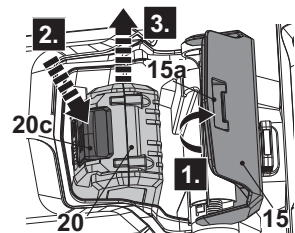

Fig. 10

## Battery pack

### Charging the battery pack

The battery pack (20) for this product has been shipped in a low charge condition. Charge it fully before first use.

Refer to the charger instruction manual (TTB805CHR-A) for the details.

### Battery capacity indicators

The battery pack (20) is equipped with the battery capacity indicators (20a) which are used to give an indication of the battery pack's remaining capacity. Press the battery capacity button (20b) to check battery capacity (Fig. 11). The LEDs will stay lit for approximately 5 seconds.

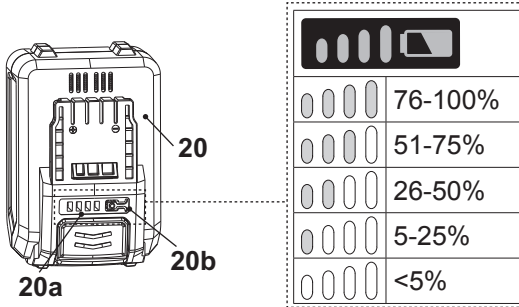

Fig. 11

## Connect battery pack

1. Make sure the start lever (3) is released and safety switch button (2) is not pressed.
2. Attach the battery pack (20) to the product. Ensure it snaps in place.
3. Insert the safety key (10) into the slot fully.
4. Your product is now ready to be used.

# In more detail...



<b>Product functions</b>	23
<b>Operation</b>	27
<b>Care and maintenance</b>	29
<b>Troubleshooting</b>	33
<b>Recycling and disposal</b>	34
<b>Guarantee</b>	35
<b>Technical specifications</b>	37
<b>Declaration of conformity</b>	39

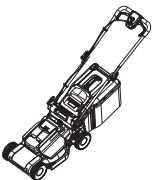

## Intended use

This cordless lawn mower TTI836LWM is designated with rated voltage of 18 V . It is designed only to be used with the battery pack which is listed in the chapter of “Technical specifications”.

The product is intended for mowing grass in domestic gardens only. It must not be used to mow unusually high, dry or wet grass, e.g. pasture grass, or to shred leaves.

For safety reasons it is essential to read the entire instruction manual before first operation and to observe all the instructions therein.

This product is intended for private domestic use only, not for any commercial trade use. It must not be used for any purposes other than those described.

## Handle height adjustment



**WARNING!** Switch the product off and wait that the cutting blade has come to a complete stop before adjusting the handle height !



Remove the safety key (10) before adjusting the handle height!

To ensure safe operation the height adjustment of the handle bar is limited to the indicated positions! Do not attempt to adjust any other height!

### Lower handle bar

Adjust the lower handle bars (6) to a suitable height according to your needs. There are three handle heights to choose.

1. Unfold and loosen the clamp levers (5) anti-clockwise on both sides of the lower handle bars (6), but do not remove them (Fig.12, step 1).
2. Hold and swing the handle assembly gently to the desired position by aligning the indication line (6a) with the indicator (8a) of transport handle (8) (Fig. 12, step 2). Ensure the handle assembly is assembled on the same height level on both side.

## Handle height adjustment

- Secure the handle assembly by folding up the clamp lever (5) towards the transport handle (8). If clamp lever (5) cannot be folded, loosen it and fold again. If it is too loose, tighten it by turning the clamp lever (5) clockwise (Fig. 12, step 3).

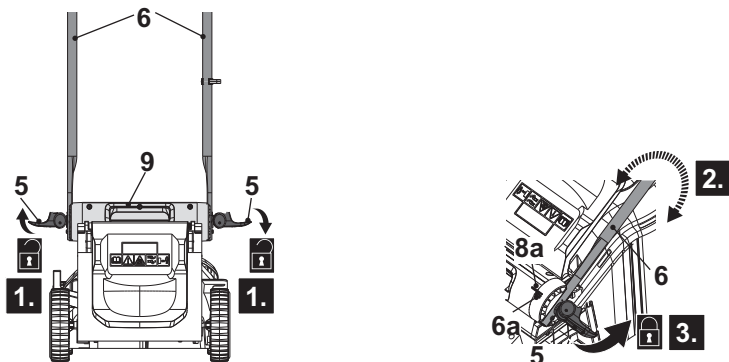

Fig. 12

### Upper handle bar

Adjust the upper handle bar (4) to a suitable height according to your needs. There are two handle heights to choose.

- Hold the upper handle bar (4) with one hand.
- Release the clamp levers (5) anti-clockwise (Fig. 13, step 1) on both side of the upper handle bar (4), then take off the clamp lever (5), the washer (5a) and the mounting bolt (5b) afterwards (Fig. 13, step 2).
- Choose and align the other mounting hole on the upper handle bar (4) with the mounting hole of the lower handle bars (6) (Fig. 13, step 3).
- Pass the mounting bolt (5b) through the mounting holes to the end.



**NOTE:** Ensure the upper handle bar (4) is assembled on the same height level on both lower handle bars (6).

- Attach the washer (5a) and screw in the clamp lever (5) clockwise, lock it by folding up the clamp lever (5) towards the handle bar. If clamp lever (5) cannot be folded, loosen it and fold again. If it is too loose, tighten it by swinging the clamp lever (5).
- Do it again on the other side. Make sure that the inter-connection cord (18) run on the upper side of the handle bars (4, 6).



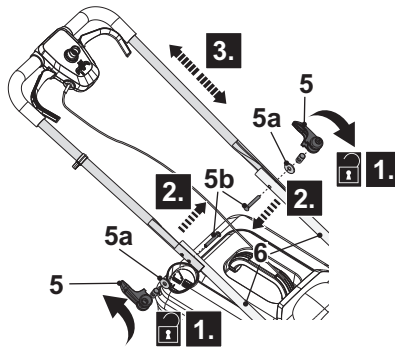

Fig 13



**WARNING!** Make sure the clamp levers (5) are properly tightened before using the product.

## Cutting height adjustment



**WARNING!** Switch the product off and wait that the cutting blade had come to a complete stop before adjusting the cutting height!  
Remove the safety key (10) before adjusting the cutting height!



Adjust the cutting height according to the needs of your lawn. The cutting height depends on the kind of lawn and its actual height. When mowing high grass, start with the maximum cutting height and make a second cut with a lower cutting height.

1. Pull the lever (11) towards the rear wheel (9) (Fig. 14, step 1).
2. Move forward or backward to adjust the cutting height (Fig. 14, step 2).
3. Release the lever (11) and ensure it engaged in the slot properly (Fig. 14, step 3).

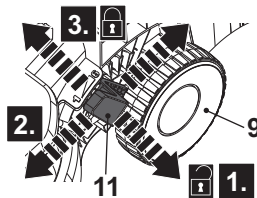

Fig. 14



**WARNING!** Ensure that the lever (11) engages in the slot after each adjustment.

## Grass catcher



**WARNING!** Do not attempt to use the product without the grass catcher attached when collecting grass – danger of flying objects! Switch the motor off and wait that the blade had come to a complete stop before removing the grass catcher!

Attach the grass catcher (7). Always carry the grass catcher (7) by its carry handle (7a).

### Indicator

The grass catcher (7) is equipped with a hatch (7e) that indicates the filling during operation.

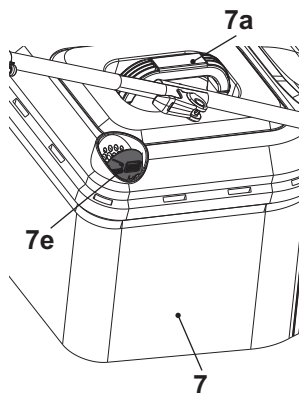

Fig. 15

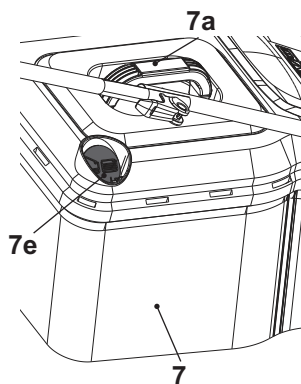

Fig. 16

1. When the hatch (7e) is opened the grass catcher has sufficient volume left to collect grass (Fig. 15).
2. When the hatch (7e) is closed, the grass catcher is full and must be emptied (Fig. 16).

### Emptying

Empty the grass catcher (7) frequently during use. Do not wait until it is completely full. We recommend emptying it when it is half full.



**NOTE:** A full grass catcher will reduce the performance of this product.

1. Switch the product off and make sure that the motor has stopped and the blade has stopped rotating.

2. Lift the deflector guard (16) and lift the grass catcher (7) off the hooks.
3. Remove the grass clippings from the rear discharge chute (19) into the grass catcher (7). Use a proper tool such as a brush.
4. Remove the grass catcher by its carry handle (7a).
5. Empty the grass clippings onto a compost heap.
6. Re-fit the grass catcher (7) to the product.



**WARNING!** Never use your hands or feet to remove grass clippings from the rear discharge chute (19) !



## General operation

1. Check the product, its battery pack and charger as well as accessories for damage before each use. Do not use the product if it is damaged or shows wear. Take care of any problem you find or have the product checked by qualified specialist.
2. Double check that accessories or attachments are properly fixed.
3. Always push the product using the grip handle (1). Keep the handles dry to ensure safe support. Use the self-propelling function if required.
4. Ensure that the air vents are always unobstructed and clear. Clean them if necessary with a soft brush. Blocked air vents may lead to overheating and damage the product.
5. Switch the product off immediately if you are disturbed while working by other people entering the working area. Always let the product come to complete stop before putting it down.
6. Do not overwork yourself. Take regular breaks to ensure you can concentrate on the work and have full control over the product.

## Starting/Stopping



**WARNING!** Before starting, put the product on a flat surface free of high grass! Clean the underside of the deck!  
Start the motor carefully according to instructions. Keep your feet well away from the cutting blade (12d)!  
Do not tilt the product when starting the motor.

## Grass catcher

### Starting / stopping



**NOTE:** The product can only be started by pressing the safety switch button (2) followed by squeezing the start levers (3). Reverse operation cannot start the product.

1. Install the battery pack (20) into the battery compartment.
2. Insert the safety key (10) into the slot fully (Fig. 17).
3. Stand behind the grip handle (1).
4. While holding the safety switch button (2) pressed (Fig. 18, step 1), pull the start levers (3) towards the grip handle (1) (Fig. 18, step 2).
5. After the mower starts, release the safety switch button (2).
6. The product starts moving forward and begins mowing.
7. Release the start levers (3) to stop the mower.

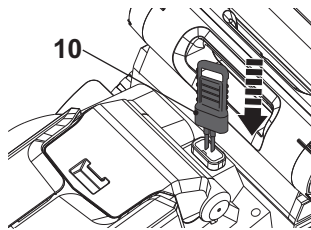

Fig. 17.

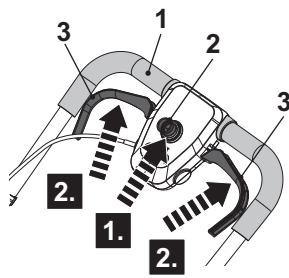

Fig. 18

## Mowing

1. Make sure that the lawn is clear of stones, sticks, wire or other objects that could damage the product or its product.
2. Do not cut wet grass because it tends to stick to the underbody of the product, preventing the proper discharge of grass clippings, and it could also cause you to slip and fall.
3. Never cut off more than one-third of the total length of the grass for a healthy lawn. In the autumn, lawns should only be cut as long as there is growth.
4. Slowly push the product forward. You may want to use the self-propelling function for assistance.

5. Mow in slight overlapping rows. The most effective pattern for mowing lawns is straight lines along one of the sides. This will keep the rows even and ensures that all the lawn is cut without missing any spots (Fig. 19).
6. Circle around flower beds. When reaching a flower bed in the middle of the lawn, cut a row or two around the circumference of the bed.
7. Pay special attention when changing direction.
8. Empty the grass catcher (7) regularly.

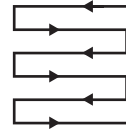

Fig. 19



**WARNING!** If the product strikes a foreign object stop immediately!

Let the product cool down and thoroughly inspect the product for damage!



Have any damage repaired before restarting!



Extensive vibration of the product during operation is an indication of damage! The product should be promptly inspected and repaired!

## After use

1. Switch the product off, disconnect the safety key (10), remove the battery pack (20) and let it cool down.
2. Check, clean and store the product as described below.

## The golden rules for care



**WARNING!** Always switch the product off, remove the battery pack (20) and safety key (10). Let the product cool down before performing inspection, maintenance and cleaning work!



1. Keep the product clean. Remove debris from it after each use and before storage.
2. Regular and proper cleaning will help ensure safe use and prolong the life of the product.
3. Inspect the product before each use for worn and damaged parts. Do not operate it if you find broken and worn parts.



**WARNING!** Only perform repairs and maintenance work according to these instructions! All further works must be performed by a qualified specialist!

## General Cleaning

1. Clean the product with a dry cloth. Use a brush for areas that are hard to reach.
2. Remove stubborn dust with high pressure air (max. 3 bar).



**NOTE:** Do not use chemical, alkaline, abrasive or other aggressive detergents or disinfectants to clean this product as they might be harmful to its surfaces.

3. Check for any damage and wear. Repair damages in accordance with this instruction manual or take it to an authorised service centre before using the product again.

## Spare parts / Replacement parts

The following parts of this product may be replaced by the consumer. Spare parts are available at an authorized dealer or through our customer service.

## Underbody and cutting blade



**WARNING!** Wear safety gloves when working on the blade and close to it! Use proper tools to remove debris, e. g. a wooden stick! Never use your bare hands!



Always use original spare parts for replacement. The cutting blade must be replaced by an identification no. ref. A056017900. Do not attach any other type of cutting blade!

The replacement of the cutting blade should be done by a qualified specialist! Rework or sharpening blades is not recommended unless it is done by a repair service or a similarly qualified specialist!

1. Keep the underbody and cutting blade (12d) clean and free of debris. Remove clippings from the rear discharge chute (19).
2. Check all fasteners, such as nuts and bolts, periodically for tightness before operation. After prolonged use, especially in sandy soil conditions, the cutting blade will become worn and lose some of the original shape. The cutting efficiency will be reduced and the cutting blade should be replaced.
3. Keep the cutting blade (12d) sharp to ensure a good cutting performance. Replace a worn or damaged cutting blade with a new one of the same type or have it sharpened by a qualified specialist.
4. Loosen the hex nut (12e) anti-clockwise using a suitable wrench (Size 17 mm) and remove it together with the cutting blade (12d) (Fig. 20).

5. Replace the cutting blade (12d) with a new one of the same type. Check the status of flange (12c), the bushing (12b) onto the spindle (12a) firstly, then attach the cutting blade (12d) and hex nut (12e) properly. Tighten the hex nut (12e) clockwise with 20 Nm min, 25 Nm max. to ensure safe operation of your product.
6. Replace this cutting blade after 50 hours mowing or 2 years whichever is sooner regardless of condition. If the cutting blade is cracked or damaged, you must immediately replace it with a new one.
7. Lubricate the cutting blade (12d) after each use to prolong the life span of cutting blade and product. Apply light machine oil along the edge of the cutting blade.

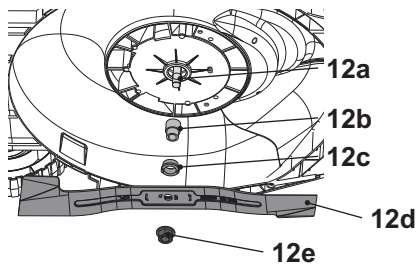

Fig. 20

## Grass catcher

1. Inspect the grass catcher (7) before each use. Do not use it if you find any damage.
2. Clean the grass catcher (7) after operation using water and mild soap.
3. Let the grass catcher (7) dry thoroughly before storing to avoid mildew.

## Inter-connection cord

Check the inter-connection cord (18) before each use.



**WARNING!** Do not use the product with a defective or a loose inter-connection cord (18)!

## Repair

This product does not contain any parts that can be repaired by the consumer. Contact an authorised service centre or a similarly qualified person to have it checked and repaired.

## Storage

---

1. Switch the product off, disconnect the safety key (10) and remove the battery pack (20) before storage.
2. Clean the product as described above.
3. Fold the handle assembly to the storage position.
4. Store the product and its accessories in a dark, dry, frost-free, well-ventilated place.
5. Always store the product in a place that is inaccessible to children. The ideal storage temperature is between 10 °C and 30 °C.
6. We recommend using the original package for storage or covering the product with a suitable cloth or enclosure to protect it against dust.

## Transportation

---

1. Switch the product off, disconnect the safety key (10) and remove the battery pack (20) before transporting it anywhere.
2. Attach transportation guards, if applicable.
3. Always transport the product by its transport handle (8).
4. Protect the product from any heavy impact or strong vibrations which may occur during transportation in vehicles.
5. Secure the product to prevent it from slipping or falling over, damage and injury.

## Troubleshooting

---

Suspected malfunctions are often due to causes that the users can fix themselves. Therefore check the product using this section. In most cases the problem can be solved quickly.



**WARNING!** Only perform the steps described within these instructions! All further inspection, maintenance and repair work must be performed by an authorised service centre or a similarly qualified specialist if you cannot solve the problem yourself!



<b>Problem</b>	<b>Possible cause</b>	<b>Solution</b>
1. Product does not start	1.1. Battery pack is not properly attached 1.2. Battery pack is discharged 1.3. Battery pack is damaged 1.4. Other electrical defect to the product 1.5. Safety key (10) not properly inserted	1.1. Attach properly 1.2. Remove and charge battery pack 1.3. Check by a specialist electrician 1.4. Check by a specialist electrician 1.5. Insert properly
2. Product does not reach full power	2.1. Battery pack capacity too low 2.2. Air vents are blocked	2.1. Charge battery pack 2.2. Clean the air vents
3. Cutting result is unsatisfactory	3.1. Cutting blade is dull / damaged 3.2. Cutting material exceeds capacity 3.3. Cutting height is incorrect	3.1. Replace with a new one 3.2. Only cut materials according to the product capacity. 3.3. Adjust the cutting height
4. Product suddenly stops	4.1. Battery pack is discharged 4.2. Battery pack is too hot 4.3. Cutting device is blocked	4.1. Remove and charge battery pack 4.2. Remove battery pack and let it cool down 4.3. Remove blockage
5. Excessive vibration or noise	5.1. Cutting device is dull/ damaged 5.2. Cutting material exceeds capacity 5.3. Cutting height is incorrect 5.4. Bolts/nuts are loosen	5.1. Replace with a new one 5.2. Only cut materials according to the product capacity 5.3. Adjust the cutting height 5.4. Tighten bolts/nuts

## Recycling and disposal

---



Waste electrical products should not be disposed of with household waste. Please recycle where facilities exist.

Check with your Local Authority or local store for recycling advice.

### **For further information visit [www.recycle-more.co.uk](http://www.recycle-more.co.uk).**

The product comes in a package that protects it against damage during shipping.

Keep the package until you are sure that all parts have been delivered and the product is working properly. Recycle the package afterwards.

### **Disposal of an exhausted battery pack**



The battery is Li-Ion type. To preserve natural resources, please recycle or dispose of the battery pack properly. Consult your local waste authority for information regarding available recycling and / or disposal options.

Discharge your battery pack by operating your tool, then remove the battery pack from the tool and cover the battery pack connections with heavy duty adhesive tape to prevent short circuit and energy discharge.

Do not attempt to open or remove any of the components.

## Guarantee

---

We take special care to select high quality materials and use manufacturing techniques that allow us to create products incorporating design and durability. This product has a manufacturer's guarantee of 2 years against manufacturing defects, from the date of purchase (if bought in store) or date of delivery (if bought online), at no additional cost for normal (non-professional or commercial) household use.

To make a claim under this guarantee, you must present your proof of purchase (such as a sales receipt, purchase invoice or other evidence admissible under applicable law), please keep your proof of purchase in a safe place. For this guarantee to apply, the product you purchased must be new, it will not apply to second hand or display products. Unless stated otherwise by applicable law, any replacement product issued under this guarantee will only be guaranteed until expiry of the original period guarantee period.

This guarantee covers product failures and malfunctions provided the product was used for the purpose for which it is intended and subject to installation, cleaning, care and maintenance in accordance with the information contained in these terms and conditions, in the user manual and standard practice, provided that standard practice does not conflict with the user manual.

This guarantee does not cover defects and damage caused by normal wear and tear or damage that could be the result of improper use, faulty installation or assembly, neglect, accident, misuse, or modification of the product. Unless stated otherwise by applicable law, this guarantee will not cover, in any case, ancillary costs (shipping, movement, costs of uninstalling and reinstalling, labour etc), or direct and indirect damage.

Rights under this guarantee are enforceable in the country in which you purchased this product. Guarantee related queries should be addressed to the store you purchased this product from.

The guarantee is in addition to and does not affect your statutory rights.

**Manufacturer:**

Kingfisher International Products Limited  
3 Sheldon Square, W26PX London United Kingdom  
[www.kingfisher.com/products](http://www.kingfisher.com/products)

## Guarantee

---

**Distributor:**

B&Q plc

Chandlers Ford, Hants, SO53 3LE, United Kingdom

[www.diy.com](http://www.diy.com)

Screwfix Direct Limited

Trade House, Mead Avenue, Yeovil, BA22 8RT, United Kingdom

[www.screwfix.com](http://www.screwfix.com)

## Technical specifications

### General

> Rated voltage	: 18 V 
> Rated no load speed $n_0$	: 3000 min <sup>-1</sup>
> Max. cutting width	: 34 cm
> Cutting height range	: 20-70 mm, 6 levels
> Grass catcher volume	: 35 l
> Degree of protection	: IPX4
> Wheel size	: 150 mm
> Weight	: approx. 10.9 kg
> Dimensions (fully assembled)	: approx. 1475*370*840 mm

### Battery pack

> Model no.	: TTI803BAT-A
> Type	: Li-Ion, 10 x 3.7 V 
> Capacity	: 5000 mAh
> Voltage	: 18 V 
> Weight	: approx. 693 g



### Charger for battery pack

> Model no.	: TTB805CHR-A
> Rated output	: 21.4V  , 4 A

### Usable battery pack (sold separately)

> Model no.	: TTI802BAT TTI803BAT TTB812BAT
> Capacity	: 4000 mAh 5000 mAh 8000 mAh

### Usable charger (sold separately)

> Model no.	: TTB804CHR/TTB804CHR-A	TTB805CHR	TTB815CHR
> Rated output	: 21.4V  ,	21.4V  ,	21 V  ,
	2.4 A	4 A	8 A

### Sound values

> Sound pressure level $L_{pA}$	: 74 dB(A)
> Uncertainty $K_{pA}$	: 3 dB(A)
> Measured sound power level $L_{WA}$	: 86 dB(A)
> Uncertainty $K_{WA}$	: 3 dB(A)
> Guaranteed sound power level $L_{WA}$	: 88 dB(A)

### Vibration values

> Hand arm vibration $a_{h,W}$	: 0.6 m/s <sup>2</sup>
> Uncertainty K	: 1.5 m/s <sup>2</sup>

## Technical specifications

---

The sound values have been determined according to noise test code given in EN 60335-2-77, using the basic standards EN ISO 11094: 1991 and EN ISO 3744: 2010.

The sound intensity level for the operator may exceed 80 dB(A) and ear protection measures are necessary.

The declared vibration value has been measured in accordance with a standard test method (according to EN 60335-2-77) and may be used for comparing one product with another. The declared vibration value may also be used in a preliminary assessment of exposure.



**WARNING!** The vibration and noise emissions during actual use of the power tool can differ from the declared values depending on the ways in which the tool is used especially what kind of workpiece is processed; and need to identify safety measures to protect the operator that are based on an estimation of exposure in the actual conditions of use (taking account of all parts of the operating cycle such as the times when the tool is switched off and when it is running idle in addition to the trigger time).

## Rating label explanation

---

Lawn mower: TTI836LWM

TTI=TITAN brand

836=Series number

LWM=lawn mower

Battery pack: TTI803BAT-A

TTI=TITAN brand

803=Series number

BAT-A=battery pack

Charger: TTB805CHR-A

TTB=TITAN brand

805=Series number

CHR-A=Charger

# Declaration of conformity

---

In more detail...





## Customer Care and Technical Helpline

### A better way to repair your tools

Kingfisher takes special care in creating high-quality garden power tools that are designed to last. But if a fault develops with your garden power tool and you need to claim under the guarantee, the Customer Care and Technical Helpline can support with technical assistance or if required, arrange a free courier collection from your home, assess your garden power tool for fault, repair it, and return it.

Deciding to repair your product rather than buying a replacement and adding to the mountain of waste is a more sustainable choice and you will be doing your bit for the environment.

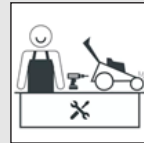
#### How does it work?

				
<b>Step 1</b> Find your proof of purchase and get in touch with the Customer Care and Technical Helpline.	<b>Step 2</b> Chat to them about the problem with your tool.	<b>Step 3</b> They will provide technical and user advice or alternatively arrange a courier collection from your home*.	<b>Step 4</b> The team will assess and test and if necessary, repair your product back to full working order.	<b>Step 5</b> Your repaired tool will be returned to you via courier within 5 - 7 working days*.



\*please note that before collection, all fuel must be removed from petrol powered machines.

### Get in touch

If you need help or more information, please contact the Customer Care and Technical Helpline:

UK: 0800 0789647

Eire: 1800 932226

Opening hours are Monday – Friday, 8am-5pm



## Availability of Spare Parts

---

Contact the customer service helpline for assistance or visit  
[www.kingfisherspares.com](http://www.kingfisherspares.com)

For assistance contact the customer services helpline:  
UK 0800 0789647 [uk@Kingfisherservice.com](mailto:uk@Kingfisherservice.com)  
EIRE 1800 932226 [eire@kingfisherservice.com](mailto:eire@kingfisherservice.com)

Further information about this product can also be found at:  
[www.kingfisher.com/products](http://www.kingfisher.com/products)

# TITAN

Manufacturer, Fabricant, Producent, Producător, Fabricante:

## UK Manufacturer:

Kingfisher International Products Limited  
3 Sheldon Square, London, W2 6PX  
United Kingdom  
[www.kingfisher.com/products](http://www.kingfisher.com/products)

## EU Manufacturer:

Kingfisher International Products B.V.  
Rapenburgerstraat 175E  
1011 VM Amsterdam  
The Netherlands  
[www.kingfisher.com/products](http://www.kingfisher.com/products)

- |    |  |   |
|----|--|---|
| EN | <a href="http://www.diy.com">www.diy.com</a><br><a href="http://www.screwfix.com">www.screwfix.com</a><br><a href="http://www.screwfix.ie">www.screwfix.ie</a> | To view instruction manuals online, visit<br><a href="http://www.kingfisher.com/products">www.kingfisher.com/products</a>                                   |
| FR | <a href="http://www.castorama.fr">www.castorama.fr</a><br><a href="http://www.bricodepot.fr">www.bricodepot.fr</a>   | Pour consulter les manuels d'instructions en ligne,<br>rendez-vous sur le site <a href="http://www.kingfisher.com/products">www.kingfisher.com/products</a> |
| PL | <a href="http://www.castorama.pl">www.castorama.pl</a>   | Aby zapoznać się z instrukcją obsługi online, odwiedź<br>stronę <a href="http://www.kingfisher.com/products">www.kingfisher.com/products</a>                |
| ES | <a href="http://www.bricodepot.es">www.bricodepot.es</a>   | Para consultar los manuales de instrucciones en línea,<br>visite <a href="http://www.kingfisher.com/products">www.kingfisher.com/products</a>               |
| PT | <a href="http://www.bricodepot.pt">www.bricodepot.pt</a>   | Para consultar manuais de instruções online, visite<br><a href="http://www.kingfisher.com/products">www.kingfisher.com/products</a>                         |
| RO | <a href="http://www.bricodepot.ro">www.bricodepot.ro</a>   | Pentru a consulta manualele de instrucțiuni online, vizitați<br><a href="http://www.kingfisher.com/products">www.kingfisher.com/products</a>                |
| TR | <a href="http://www.koctas.com.tr">www.koctas.com.tr</a>   | Kullanım kılavuzuna internet üzerinden ulaşmak için<br><a href="http://www.kingfisher.com/products">www.kingfisher.com/products</a> adresini ziyaret edin   |