

Thank you for purchasing this light fitting. Please read the instructions carefully before use to ensure safe and satisfactory operation of this product.

Please keep these instructions for future reference.

Warnings!

This is a Class 1 product and must be earthed.

Please read these instructions carefully before commencing any work. It is recommended that this fitting is installed by a qualified electrician.

Install in accordance with the IEE Wiring regulations and the Building Regulations.

To prevent electrocution switch off at mains supply before installing or maintaining this fitting. Ensure other persons cannot restore the electrical supply without your knowledge. If you are in any doubt, please consult a qualified electrician.

This light fitting should be connected to a 5 amp fused circuit.

If replacing an existing fitting, make a note of the connections.

Always use the correct type and wattage bulb. Never exceed the wattage stated.

When changing a bulb, always switch off at the mains and allow the old bulb to cool down before handling.

Dispose of used bulbs carefully.

This product is suitable for indoor use only, on normal flammable surfaces.

Using a dimmer switch

This product is suitable for use with a dimmer switch.

Please note, some energy saving bulbs are not suitable for use with a dimmer switch.

Fixing Instructions

Make sure you have the following items which are required to install this light fitting:

Small electrical screwdriver, cross head screwdriver & insulation tape.

Step 1

Referring to the diagram in step 4 overleaf, remove the fixing bracket from the wall back and attach to the wall using the screws provided. Take care to avoid damaging any concealed wiring and pipes.

Step 2

Having identified the household wiring from your existing light fitting, connect to the connection block inside the product in the following way:

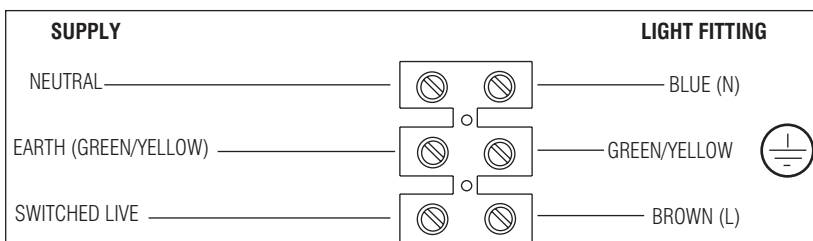

Check that.....

You have correctly identified the house wires.
The connections are tight.

No loose strands have been left out of the connection block.

Step 3

When completed, ensure that there are no bare or loose strands of wire exposed, and cover all exposed areas of the connection block with 2 layers of insulation tape.

Step 4

Ensuring the lampholder is correctly positioned, re-attach the product to the fixing bracket, by refitting the screws into the holes in the wall back and tightening the screws to secure. Product to be used in downward position only.

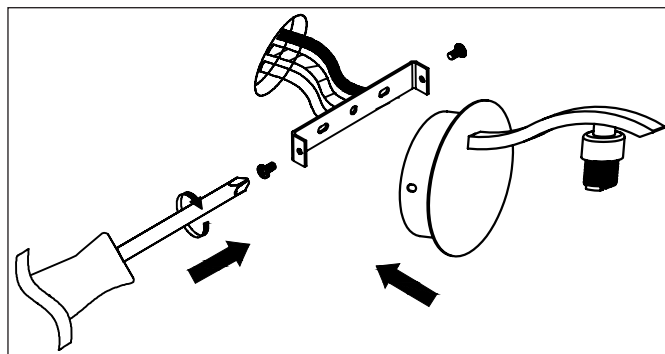

Attaching the shade

See diagram on the right. Simply screw the shade directly onto the lampholder. Do not overtighten.

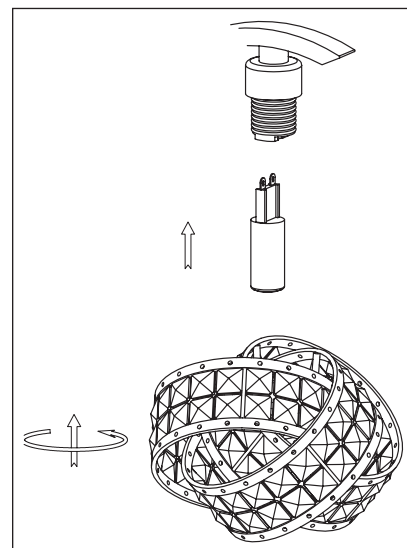

Fitting/Replacing the bulb - Max. 28W G9 Halogen

During use the bulbs and light fitting get very hot. Switch off the product and allow the bulb to cool before changing the bulb. Avoid directly touching the bulbs as this will shorten their life. Do not exceed the wattage stated on the fitting. If you use bulbs with a higher wattage the lamp holder could be damaged. This product is suitable for use with LED bulbs. Check bulb dimming capability before using with a dimmer switch.

Step 5

Replace fuse or circuit breaker and switch on. Your light is now ready for use.

Care and cleaning

Finish - We recommend cleaning with a soft dry cloth. Do not use abrasive materials as these will damage the finish.

Glass parts - Wipe with a damp cloth. Do not use abrasive materials as these will damage the finish. Take care when handling glass parts to avoid damage or injury.

Safety Information

For your safety, always switch off the supply before replacing, adjusting or cleaning.

 Waste electrical products should not be disposed of with household waste. Please recycle where facilities exist. Check with your Local Authority or retailer for recycling advice.

We have taken great care to ensure that this product reaches you in perfect condition. However, should any parts be damaged or missing please access our website: www.poolelighting.com to request spare parts or please call our Product Helpline on (01202) 690945.

We will despatch to you, within 7 working days, your missing/damaged part. When phoning please ensure you have the following information available: Name and Address, Daytime Telephone Number, Date of Purchase, Product Reference number or barcode number (on product label or on box label), Description of Missing/Damaged Part. This does not affect your statutory rights.

Manufactured by: Poole Lighting Ltd.

UK: BH17 7BY

EU: Brilliant AG, Brilliantstrasse 1, D-27442 Gnarrenburg