

# Technical Specification



Thermostatic valves are typically used for regulating the fluid to the radiators of central heating systems. They are provided with a regulating element with automatically controls the opening of the valve to keep the ambient temperature of the room where they are installed constant at the set valve. the number in the valve corresponds to a specific air temperature. Once you have selected a number, the thermostatic valve will maintain the temperature. This prevents unwanted temperature rises and achieves considerable energy saving.

The thermostatic valve can be fitted either side of the radiator but must be consistent throughout other radiators. The lock shield valve can used to balance the heating system and is used in conjunction with the thermostatic head. It is advisable to flush the system before use. The quality meets the requirement EN 215/BS7556

- Thermostatic head and reversible bi-directional body
- Built in sensor with liquid element
- Graduated scale from 0 to 5 corresponding to temperature setting ranges from 7°C to 28° with frost protection setting (as per figure)
- Fully tested to 10 bar
- Max pressure difference:0.8bar
- Nominal flow rate 173kgs/h
- Max flow temperature 120°C
- Can be mounted horizontally or vertically

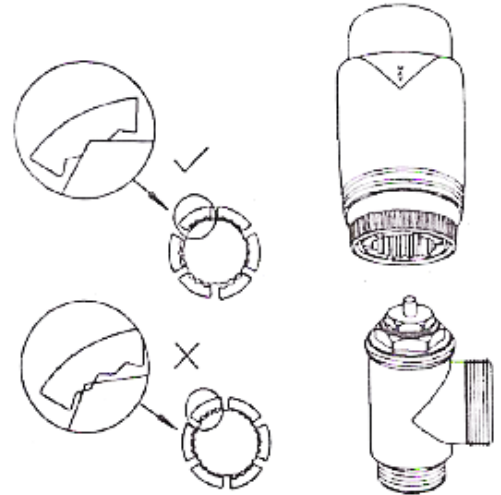

°	1	2	3	4	5
7°C	11-13°C	15-17°C	19-21°C	23-25°C	29-29°C

