

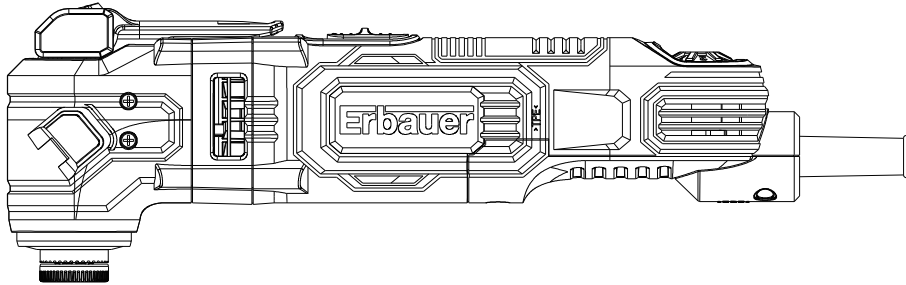

Erbauer









EAN: 3663602795100

EMT300-QC

ORIGINAL INSTRUCTIONS



	Safety instructions	8
	Product description	19
	Assembly	21
	Use	26
	Care & maintenance	30
	Guarantee	33
	Declaration of conformity	34



WARNING! Please read all safety warnings carefully and be sure that they are fully understood before handling the tool.

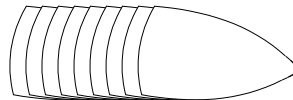
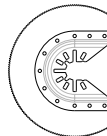
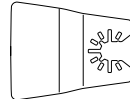
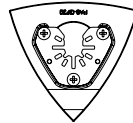
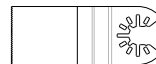
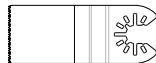
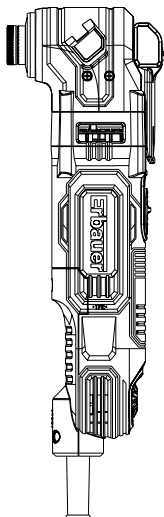



Product description

1

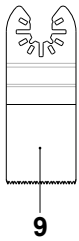
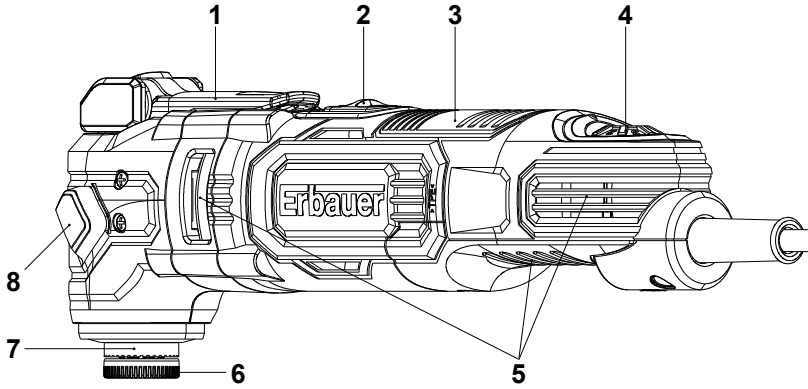

9

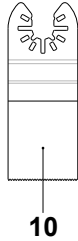

10

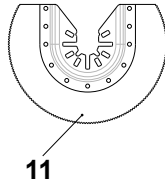

11

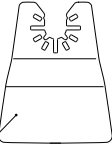

12

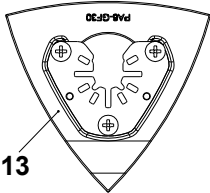

13

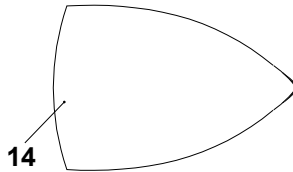

14



15

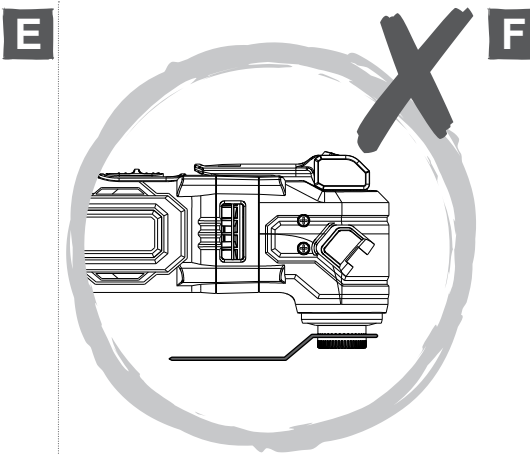
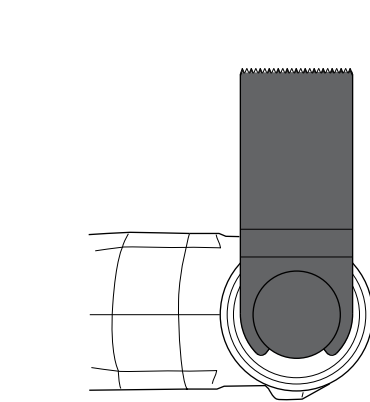
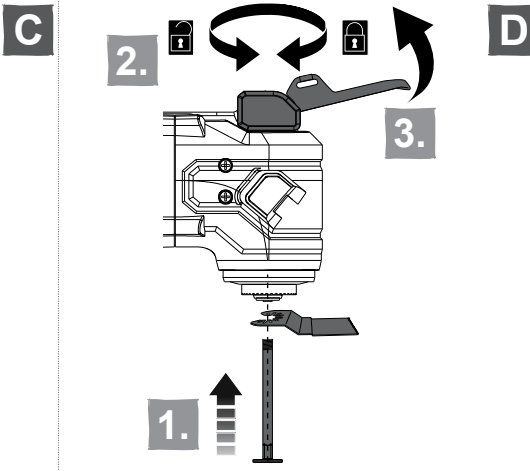
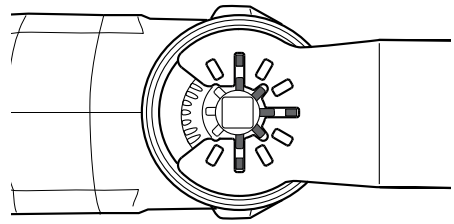
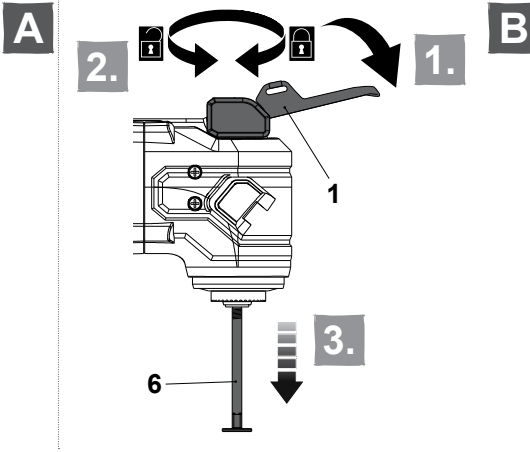



G

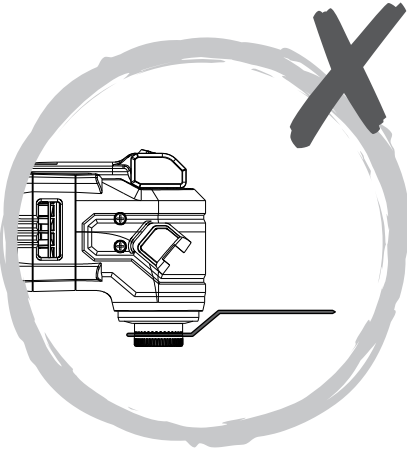

H

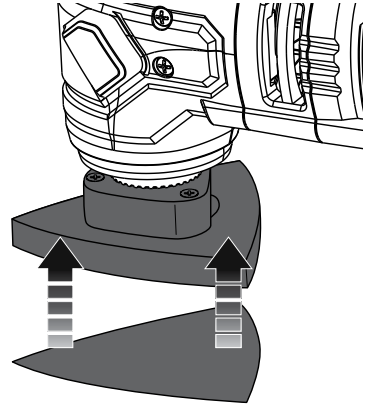

I

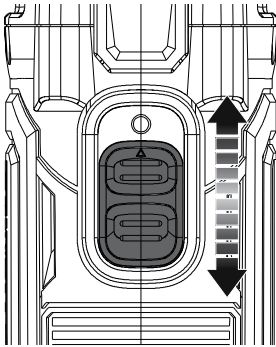

J

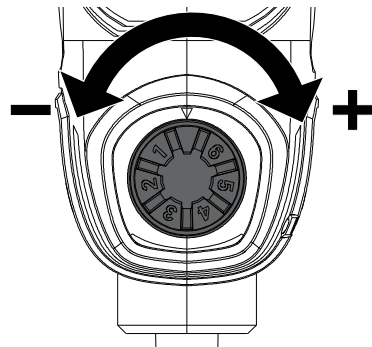

K

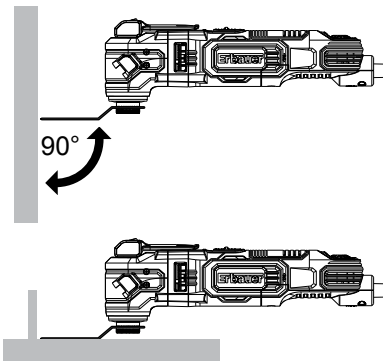

L

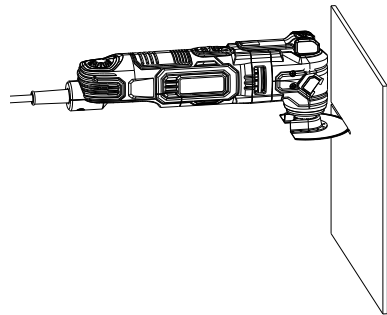



M

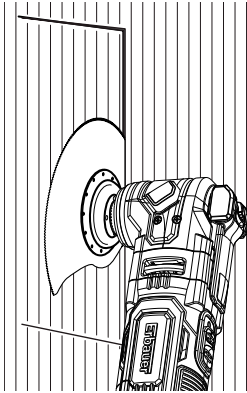

N

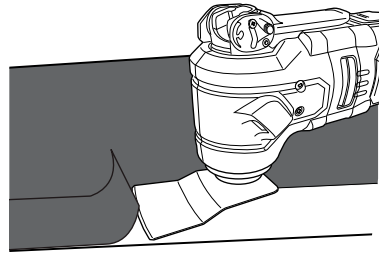



Safety instructions

GENERAL POWER TOOL SAFETY WARNING



WARNING! Read all safety warnings, instructions, illustrations and specifications provided with this power tool. *Failure to follow all instructions listed below may result in electric shock, fire and/or serious injury.*

Save all warnings and instructions for future reference.

The term “power tool” in the warnings refers to your mains-operated (corded) power tool or battery-operated (cordless) power tool.

1) WORK AREA SAFETY

- a) **Keep work area clean and well lit.** *Cluttered or dark areas invite accidents.*
- b) **Do not operate power tools in explosive atmospheres, such as in the presence of flammable liquids, gases or dust.** *Power tools create sparks which may ignite the dust or fumes.*
- c) **Keep children and bystanders away while operating a power tool.** *Distractions can cause you to lose control.*

2) ELECTRICAL SAFETY

- a) **Power tool plugs must match the outlet. Never modify the plug in any way. Do not use any adapter plugs with earthed (grounded) power tools.** *Unmodified plugs and matching outlets will reduce risk of electric shock.*

- b) **Avoid body contact with earthed or grounded surfaces, such as pipes, radiators, ranges and refrigerators.** *There is an increased risk of electric shock if your body is earthed or grounded.*
- c) **Do not expose power tools to rain or wet conditions.** *Water entering a power tool will increase the risk of electric shock.*
- d) **Do not abuse the cord. Never use the cord for carrying, pulling or unplugging the power tool. Keep cord away from heat, oil, sharp edges or moving parts.** *Damaged or entangled cords increase the risk of electric shock.*
- e) **When operating a power tool outdoors, use an extension cord suitable for outdoor use.** *Use of a cord suitable for outdoor use reduces the risk of electric shock.*
- f) **If operating a power tool in a damp location is unavoidable, use a residual current device (RCD) protected supply.** *Use of an RCD reduces the risk of electric shock.*

3) PERSONAL SAFETY

- a) **Stay alert, watch what you are doing and use common sense when operating a power tool. Do not use a power tool while you are tired or under the influence of drugs, alcohol or medication.** *A moment of inattention while operating power tools may result in serious personal injury.*
- b) **Use personal protective equipment. Always wear eye protection.** *Protective equipment such as a dust mask, non-skid safety shoes, hard hat, or hearing protection used for appropriate conditions will reduce personal injuries.*

- c) **Prevent unintentional starting. Ensure the switch is in the off-position before connecting to power source and/or battery pack, picking up or carrying the tool.** *Carrying power tools with your finger on the switch or energising power tools that have the switch on invites accidents.*
- d) **Remove any adjusting key or wrench before turning the power tool on.** *A wrench or a key left attached to a rotating part of the power tool may result in personal injury.*
- e) **Do not overreach. Keep proper footing and balance at all times.** *This enables better control of the power tool in unexpected situations.*
- f) **Dress properly. Do not wear loose clothing or jewellery. Keep your hair and clothing away from moving parts.** *Loose clothes, jewellery or long hair can be caught in moving parts.*
- g) **If devices are provided for the connection of dust extraction and collection facilities, ensure these are connected and properly used.** *Use of dust collection can reduce dust-related hazards.*
- h) **Do not let familiarity gained from frequent use of tools allow you to become complacent and ignore tool safety principles.** *A careless action can cause severe injury within a fraction of a second.*

4) POWER TOOL USE AND CARE

- a) **Do not force the power tool. Use the correct power tool for your application.** *The correct power tool will do the job better and safer at the rate for which it was designed.*
- b) **Do not use the power tool if the switch does not turn it on and off.** *Any power tool that cannot be controlled with the switch is dangerous and must be repaired.*

- c) **Disconnect the plug from the power source and/or the battery pack from the power tool before making any adjustments, changing accessories, or storing power tools.** *Such preventive safety measures reduce the risk of starting the power tool accidentally.*
- d) **Store idle power tools out of the reach of children and do not allow persons unfamiliar with the power tool or these instructions to operate the power tool.** *Power tools are dangerous in the hands of untrained users.*
- e) **Maintain power tools. Check for misalignment or binding of moving parts, breakage of parts and any other condition that may affect the power tool's operation. If damaged, have the power tool repaired before use.** *Many accidents are caused by poorly maintained power tools.*
- f) **Keep cutting tools sharp and clean.** *Properly maintained cutting tools with sharp cutting edges are less likely to bind and are easier to control.*
- g) **Use the power tool, accessories and tool bits etc. in accordance with these instructions, taking into account the working conditions and the work to be performed.** *Use of the power tool for operations different from those intended could result in a hazardous situation.*
- h) **Keep handles and grasping surfaces dry, clean and free from oil and grease.** *Slippery handles and grasping surfaces do not allow for safe handling and control of the tool in unexpected situations.*

5) SERVICE

- a) **Have your power tool serviced by a qualified repair person using only identical replacement parts.** *This will ensure that the safety of the power tool is maintained.*

SAFETY WARNINGS FOR SANDER

- a) **Hold power tool by insulated gripping surfaces only, when performing an operation where the cutting accessory may contact hidden wiring or its own cord. Cutting accessory contacting a “live” wire may make exposed metal parts of the power tool “live” and could give the operator an electric shock.**
- b) *Take special care to protect yourself and people around against dusts, including the following:*
 - *All persons entering the work area must wear an appropriate dust mask specially designed for protection against harmful / toxic dusts, in addition to using the dust extraction facility and keeping work area well ventilated.*
 - *Children and pregnant women must not enter the work area.*
 - *Do not eat, drink or smoke in the work area.*
- c) *Some wood and wood type products especially MDF (Medium Density Fibreboard) can produce dust that can be hazardous to your health. We recommend the use of a dust mask with replaceable filters when using this product in addition to using the dust extraction facility.*
- d) *The power tool shall not be wet or applied in wet environment.*
- e) *The voltage of the power source must agree with the voltage specified on the rating label of the machine.*
- f) *Check the product, its power cord and plug as well as accessories for damage before each use. Do not use the product if it is damaged or shows wear.*
- g) *Double check that the accessories and attachments are properly fixed. One minute testing running in no-load condition will be helpful to identify any problems.*
- h) *Secure the workpiece. A workpiece clamped with clamping devices or in a vice is held more secure than by hand.*
- i) *Keep the handles dry to ensure safe control. Grip the product securely with two hands so you have full control at all times.*

- j) *Ensure that the air vents are always unobstructed and clear. Clean them if necessary with a soft brush. Blocked air vents may lead to overheating and damage the product.*
- k) *Switch the product off immediately if you are disturbed while working by other people entering the working area. Always let the product come to complete stop before putting it down.*
- l) *Do not overwork yourself. Take regular breaks to ensure you can concentrate on the work and have full control over the product.*
- m) *Always keep the power cord behind the power tool.*

The following information applies to professional users only but is good practice for all users:

ADDITIONAL SAFETY WARNINGS FOR CONSTRUCTION DUST

The updated Control of Substances Hazardous to Health Regulations 1st October 2012 now also targets to reduce the risks associated with silica, wood and gypsum dusts.

Construction workers are one of the at-risk groups within this because of the dust that they breathe: silica dust is not just a nuisance; it is a real risk to your lungs!

Silica is a natural mineral present in large amounts in things like sand, sandstone and granite. It is also commonly found in many construction materials such as concrete and mortar. The silica is broken into very fine dust (also known as Respirable

Crystalline Silica or RCS) during many common tasks such as cutting, drilling and grinding. Breathing in very fine particles of crystalline silica can lead to the development of:

- lung cancer
- Silicosis
- Chronic obstructive pulmonary disease (COPD).

And breathing in fine particles of wood dust can lead to the development of Asthma. The risk of lung disease is linked to people who regularly breathe construction dust over a period of time, not on the odd occasion.

To protect the lung, the COSHH Regulations sets a limit on the amount of these dusts that you can breathe (called a Workplace Exposure Limit or WEL) when averaged over a normal working day. These limits are not a large amount of dust: when compared to a penny it is tiny – like a small pinch of salt:

This limit is the legal maximum; the most you can breathe after the right controls have been used.

How to reduce the amount of dust?

1. Reduce the amount of cutting by using the best sizes of building products.
2. Use a less powerful tool e.g. a block cutter instead of angle grinder.
3. Using a different method of work altogether – e.g. using a nail gun to direct fasten cable trays instead of drilling holes first.

Please always work with approved safety equipment, such as those dust masks that specially designed to filter out microscopic particles and use the dust extraction facility at all time.

For more information please see the HSE website:

<http://www.hse.gov.uk/construction> or <http://www.hse.gov.uk/pubns/cis69.pdf>



WARNING! Some dust particles created by power sanding, sawing, grinding, drill and other construction jobs contain chemicals known to cause cancer, birth defects or other reproductive harm. Some examples of these chemicals are:

- Lead from lead-based paints.
- Crystalline silica from bricks and cement and other masonry products.
- Arsenic and chromium from chemically treated timber.

Your risk from these exposures varies, depending upon how often you do this type of work. To reduce your exposure to these dusts:

- Work in a well-ventilated.
- Work with approved protective equipment, such as those dust masks that are specially designed to filter microscopic particles.



WARNING! Certain dusts, such as oak or beech dust, are considered as carcinogenic, especially in connection with woodtreatment additives (chromate, wood preservative).

Materials containing asbestos may only be worked by specialists. Use a dust extraction system suitable for the material as far as possible.

VIBRATION

The European Physical Agents (Vibration) Directive has been brought in to help reduce hand arm vibration syndrome injuries to power tool users. The directive requires power tool manufacturers and suppliers to provide indicative vibration test results to enable users to make informed decisions as to the period of time a power tool can be used safely on a daily basis and the choice of tool.

SEE TECHNICAL SPECIFICATIONS IN THE INSTRUCTION MANUAL FOR THE VIBRATION LEVELS OF YOUR TOOL.

The declared vibration emission value should be used as a minimum level and should be used with the current guidance on vibration.

Calculating the actual period of use can be difficult and the HSE website has further information.

The declared vibration total value has been measured in accordance with EN 62841- 1 and EN 62841-2-4 and may be used for compare one tool with another.

The declared vibration total value may also be used in a preliminary assessment of exposure.



WARNING! The vibration emission during actual use of the power tool can differ from the declared total value depending on the ways in which the tool is used:

- How the materials are grinded, cut or drilled.
- If the tool is in good condition and well maintained.
- Use correct accessory for the tool and ensure it is sharp and in good condition.
- The tightness of the grip on the handles.
- The tool is being used as intended by its design and these instructions.

While working with this power tool, hand/arm vibrations occur. Adopt the correct working practices in order to reduce the exposure to vibration. This tool may cause hand-arm vibration syndrome if its use is not adequately managed.



WARNING! Identify safety measures to protect the operator that are based on an estimation of exposure in the actual conditions of use (taking account of all parts of the operating cycle such as the times when the tool is switched off and when it is running idle in addition to the trigger time).

Note:

- The use of other tools will reduce the users' total working period on this tool.
- Helping to minimise your vibration exposure risk. ALWAYS use sharp chisels, drills and blades.
- Maintain this tool in accordance with these instructions and keep well lubricated (where appropriate).
- Avoid using tools in temperatures of 10 °C or less. Plan your work schedule to spread any high vibration tool use across a number of days.

Health surveillance

All employees should be part of an employer's health surveillance scheme to help identify any vibration related diseases at an early stage, prevent disease progression and help employees stay in work.

VIBRATION AND NOISE REDUCTION

To reduce the impact of noise and vibration emission, limit the time of operation, use low-vibration and low-noise operating modes as well as wear personal protective equipment.

Take the following points into account to minimise the vibration and noise exposure risks:

1. Only use the product as intended by its design and these instructions.
2. Ensure that the product is in good condition and well maintained.

3. Use correct attachments for the product and ensure they are in good condition.
4. Keep tight grip on the handles/grip surface.
5. Maintain this product in accordance with these instructions and keep it well lubricated (where appropriate).
6. Plan your work schedule to spread any high vibration tool use across a longer period of time.
7. Prolonged use of the product exposes the user to vibrations that can cause a range of conditions collectively known as hand-arm vibration syndrome (HAVS) e.g. fingers going white; as well as specific diseases such as carpal tunnel syndrome. To reduce this risk when using the product, always wear protective gloves and keep your hands warm.

RESIDUAL RISKS

Even if you are operating this product in accordance with all the safety requirements, potential risks of injury and damage remain. The following dangers can arise in connection with the structure and design of this product:

1. Health defects resulting from vibration emission if the product is being used over long periods of time or not adequately managed and properly maintained.
2. Injuries and damage to property due to broken attachments or the sudden impact of hidden objects during use.
3. Danger of injury and property damage caused by flying objects or poor power tool accessories.



WARNING! This product produces an electromagnetic field during operation! This field may under some circumstances interfere with active or passive medical implants! To reduce the risk of serious or fatal injury, we recommend persons with medical implants to consult their doctor and the medical implant manufacturer before operating this product!



Product description

Part index

The index below refers to Fig. 1 on page 4.

- | | |
|-------------------------|----------------------------------|
| 1. Flange release lever | 9. Plunge saw blade (for wood) |
| 2. On/Off switch | 10. Plunge saw blade (for metal) |
| 3. Hand grip | 11. HSS segment saw blade |
| 4. Speed dial | 12. Scraper |
| 5. Air vents | 13. Sanding base plate |
| 6. Flange bolt | 14. Sanding paper (9 pieces) |
| 7. Tool holder | 15. Flange bolt with small head |
| 8. LED work light | |

Symbols

On the product, the rating label and within these instructions you will find among others the following symbols and abbreviations. Familiarize yourself with them to reduce hazards like personal injuries and damage to property.



Always wear eye protection.



Always wear ear protection.



Wear a dust mask.



Wear protective gloves.



Lock / to tighten or secure.



Unlock / to loosen.



Note / Remark.



Caution / Warning.



Correct.



Wrong.



To reduce the risk of injury, user must read instruction manual.



Switch the product off and disconnect it from the power supply before assembly, cleaning, adjustments, maintenance, storage and transportation.



This product is of protection class II. That means it is equipped with enhanced or double insulation.



The product complies with the applicable European directives and an evaluation method of conformity for these directives was done.



WEEE symbol. Waste electrical products should not be disposed of with household waste. Please recycle where facilities exist. Check with your Local Authority or local store for recycling advice.



UK Conformity Assessed.

yyWxx Manufacturing date code; year of manufacturing (20yy) and week of manufacturing (Wxx)



4 metre Power Cord Length



Quick Change Accessory Technology

Technical data

Rated voltage, frequency	: 220-240 V~, 50 Hz
Rated power input	: 300 W
No-load speed	: 11000-20000 /min
Sanding base plate size	: Delta 80 mm
Oscillation angle	: 3.2°
Protection class	: II 
Weight	: Approx. 1.5 kg
Sound pressure level L_{pA}	: 74 dB(A)
Sound power level L_{WA}	: 85 dB(A)
Uncertainty K_{pA}, K_{WA}	: 3 dB(A)
Vibration value a_h	: 9 m/s ²
Uncertainty K	: 1.5 m/s ²

The sound emission values have been obtained according to the noise test code given in EN 62841-1 and EN 62841-2-4. The noise for the operator may exceed 80 dB(A) and ear protection measures are necessary.

Rating label explanation

EMT300-QC = Model number

E = Erbauer

MT = Multi tool

300 = Power (Watts)

QC = Quick Change



Assembly

01

Unpacking

1. Unpack all parts and lay them on a flat, stable surface.
2. Remove all packing materials and shipping devices, if applicable.
3. Make sure the delivery contents are complete and free of any damage. If you find that parts are missing or show damage do not use the product but contact your dealer. Using an incomplete or damaged product represents a hazard to people and property.
4. Ensure that you have all the accessories and tools needed for assembly and operation. This also includes suitable personal protective equipment.



WARNING! The product must be fully assembled before operation! Do not use a product that is only partly assembled or assembled with damaged parts!



Wear protective gloves for this assembly work and always lay the product on a flat and stable surface while assembling.

Follow the assembly instructions step-by-step and use the pictures provided as a visual guide to easily assemble the product!



Do not connect the product to power supply before it is completely assembled!



WARNING! The product and the packaging are not children's toys! Children must not play with plastic bags, sheets and small parts! There is a danger of choking and suffocation!

02



Multi tool accessories



WARNING! Always use accessory according to the intended use!
Observe the technical requirements of this product when purchasing and using tool accessories!

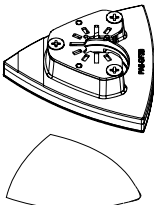

Tool attachments are available in various shapes and sizes. Below is only overview of the supplied tool attachments. Ask in store for more choices.

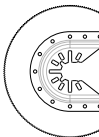
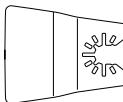
Tool attachment		Material	Application
Sanding base plate & Sanding paper		Bare or painted wood, plaster, and other surface, depending on grain size (grit) of sanding paper	Flat sanding and reaching into corners and along edges
Plunge saw blade		Wood, plastic, drywall, soft metals	Separating or flush/plunge saw cutting, also for sawing close to edges, in corners and hard to reach areas
HSS segment saw blade		Wood, plastic, drywall, nonferrous metals	
Scraper		Paint & varnish, bonded carpet, soft adhesives, vinyl flooring, wood and other floor coverings	Scraping on hard surfaces, e. g. scraping of carpet or wallpaper



This product can also be used with accessories of other brands. Carefully read the safety warnings and observe the technical specification of the respective accessories before use and purchase.

The provided flange bolt with small head (15) enables the product to work with compatible sanding base plates which cannot be attached directly to the tool holder of this product.

Ask in store for suitable options.

03

Assembly of accessories

Attaching (Fig. A, B and C)

1. Open the flange release lever (1) fully from locking mechanism (Fig. A, step 1).
2. Turn the flange release lever (1) anti-clockwise (Fig. A, step 2) until the flange bolt (6) can be removed from the tool holder (7) (Fig. A, step 3).
3. Align the grooves on the suitable accessory with the ribs on the tool holder (7) at desired working position/angle (Fig. B).
4. Insert the flange bolt (6) into the tool holder (7) to keep the accessory in position (Fig. C, step 1) and then turn the flange release lever (1) clockwise to clamp the accessory firmly (Fig. C, step 2).
5. Close the flange release lever (1) to lock mechanism until you hear a “click” sound (Fig. C, step 3).
6. Check that the accessory is reliably clamped at desired angle and make adjustment if necessary.



WARNING! Check that the accessories are correctly attached. Incorrect or insecurely fastened accessories can come loose during operation and cause a hazard.



Depending on application needs, the plunge saw blade can also be assembled at $\pm 90^\circ$ (Fig. D). Never adjust the saw blade pointing backwards towards the handle (Fig. E).



WARNING! For safety reason, please ensure that the accessory is assembled with the correct orientation (Fig. F and G).

Detaching



WARNING! For all work, and when changing accessories, always wear protective gloves. Some tool attachments are sharp and hot after use! Handle them with care! Wear safety gloves when handling to avoid injuries like burns and cuts!



1. Open the flange release lever (1) fully from initial locking position (Fig. A, step 1).
2. Turn the flange release lever (1) anti-clockwise (Fig. A, step 2) until the flange bolt (6) can be removed from the tool holder (7) (Fig. A, step 3).
3. Remove the accessory from the tool holder (7).
4. Insert the flange bolt (6) into the tool holder (7) and then turn the flange release lever (1) clockwise to fix the flange bolt (6).
5. Close the flange release lever (1) to lock mechanism until hearing a “click” sound.

04

Sanding paper

Choosing the right sanding paper

Sanding paper is available with different grain sizes (grit) and for different material. The grain size is indicated with a number on the reverse of the sanding paper, the higher the number the finer is the grain size.

Grain size	Class	Application
< 80	Coarse	Removal of paint and varnish, preparation of rough surfaces.
80-120	Medium	For face sanding and removing small irregularities.
>180	Fine	Finishing, cleaning plaster and water stain from wood.



- Only use suitable sanding papers in terms of application and size. Do not use the papers that are bigger than the base plate of the product.
- Replace worn or damaged sanding papers immediately.
- Start with a coarse sanding paper and finish with a fine-grained one to achieve a satisfactory result.
- Do not use the same sanding paper on different materials, e. g. do not use the sanding paper that has been used for sanding metal to sand wood. Small metal particles remaining in the sanding paper will lead to scratches.

Attaching/Removing:

- With the hook-and-loop system, sanding paper (14) can be simply pressed on the sanding base plate (13). Align and attach the required sanding paper to the base plate and slightly press the sanding paper to fix it.
- Sanding paper can be simply removed by pulling off.



Always remove dust and chips from the sanding base plate (13) before attaching sanding paper (14) to reduce the wear of sanding base plate and sanding paper.

If one corner and/or edge of the sanding paper (14) is worn, it can be reattached and rotated by 120° to use the next corner and/or edge.



Use

Intended use

This product is intended for dry sanding and cutting on wood, plastic as well as plasterboard, especially for sanding small surfaces (e.g. corners or edges) and plunge/flush cutting.

This product can also be used with attachments of other popular brands when they are suitable for the tool holder (incl. pins) and locking flange. Carefully read the safety warnings and observe the technical specification of the respective attachment before purchase and use.

Before you start

01 Protection



Controls

01 On/Off switch (Fig. 1)

Mode	Action	Application
On	Shift the On/Off switch (2) forward to "1"	The power tool will run continuously.
Off	Shift the On/Off switch (2) backward to "0"	Switch the power tool off.

02 Automatic LED work light

LED work light (8) will automatically illuminate the working zone when you press the On/Off switch (2).



WARNING! Do not look directly into LED light!

03 Speed dial (Fig. J)

Limit the maximum speed using the speed dial (4) depending on material and application.

1. Turn the speed dial (4) clockwise to increase the speed.
2. Turn the speed dial (4) anti-clockwise to decrease the speed.

Operation

01 Sanding

- Ensure the workpiece is free of obstacles like nails or screws before operation. Remove them if required. Where possible, secure smaller workpieces to prevent them from moving under the product.
- Hold the product with one hand on the head of housing or front section of hand grip and with the other hand on the hand grip.
- Switch the product on and wait until it runs at full speed before placing it on the workpiece.
- Move the product slowly and steadily over the workpiece surface in parallel and overlapping strokes.
- Only apply the least possible pressure to keep the product flat on the workpiece. Higher pressure will not increase but lower the performance of the product, increase wear of the sanding paper and leads to uneven results.
- Work with dust extraction system particularly when sanding coats of varnish as the varnish could melt and smear the surface of the workpiece and the sanding paper.
- Keep the product moving at all times, do not stop in one position to avoid grooves.
- Lift the product from the workpiece before switching it off.

02 Cutting (Fig. K, L and M)



WARNING! Only perform plunge cutting into soft materials such as plasterboard or soft wood! Never attempt to conduct any plunge cutting into hard materials such as metal! Use only the appropriate saw blade for cutting! If you are unsure when cutting, consult with an experienced person – risk of injury!

Switch the product off, let it come to a complete stop and disconnect it from the power supply if the attachment gets stuck in the workpiece. Only then free the jammed attachment.

The provided saw blades can be used for plunge or flush cutting as shown in Fig. K, L and M.

- Mark the cutting line and ensure that the workpiece will not move during operation.
- Ensure that the cutting depth of the saw blade is higher than the workpiece thickness.
- Switch the product on, align the saw blade with the marked cutting line and place the saw blade on the workpiece.
- Apply light pressure and carefully lead the saw blade into the workpiece until the desired depth is reached.
- Lift the product from the workpiece before switching it off.

03 Scraping (Fig. N)



WARNING! Switch the product off, let it come to a complete stop and disconnect it from the power supply if the attachment gets stuck in the workpiece. Only then free the jammed attachment.

- Switch the product on before placing the scraper on the workpiece.
- Adjust the product to a proper scraping angle according to the material of workpiece.
- Keep the product at a flatter angle to the workpiece when processing soft materials, such as wood. Otherwise the scraper can cut into the workpiece.
- Move the product forward at an even speed.
- Only apply as much pressure as necessary. Higher pressure will not increase but lower the performance of the product and leads to uneven results.
- Lift the product from the workpiece before switching it off.



After use

- Switch the product off, wait for complete stop, disconnect it from the power supply and let it cool down.
- Detach the tool attachments from the product.
- Check, clean and store the product as described below.



Care & maintenance



WARNING! Always switch the product off, disconnect the product from the power supply and let the product cool down before performing inspection, maintenance and cleaning work!



Only perform care and maintenance work according to these instructions! All further works must be performed by a qualified specialist!

Clean

1. Detach the tool attachments from the product.
2. Clean the product with a dry cloth. Use a brush for areas that are hard to reach.
3. In particular clean the sanding base plate, tool holder, speed dial, switches and air vents after every use with a cloth and brush.
4. Remove stubborn dirt with high pressure air (max. 3 bar).
5. Check for worn or damaged parts. Replace worn parts as necessary or contact an authorised service centre for repair before using the product again.



Do not use chemical, alkaline, abrasive or other aggressive detergents or disinfectants to clean this product as they might be harmful to its surfaces.

Maintenance

Your power tool requires no additional lubrication or maintenance.

There are no user serviceable parts in your power tool.

Before and after each use, check the product and accessories (or attachments) for wear and damage. If required, exchange them for new ones as described in this instruction manual.

01 Power cord

If the replacement of the supply cord is necessary, this has to be done by the manufacturer or his agent in order to avoid a safety hazard.

02 UK plug (only for UK market)

Replacement of the plug shall always be carried out by the manufacturer of the tool or his service organization and follow the instructions below.

IMPORTANT: The wires in the mains lead are coloured in accordance with the following code:

Blue – Neutral Brown – Live

As the colours of the wire in the mains lead of this product may not correspond with the coloured marking identifying the terminals in your plug, proceed as follows. The wire, which is coloured blue, must be connected to the terminal, which is marked with N or coloured black. The wire, which is coloured brown, must be connected to the terminal, which is marked L or coloured red.

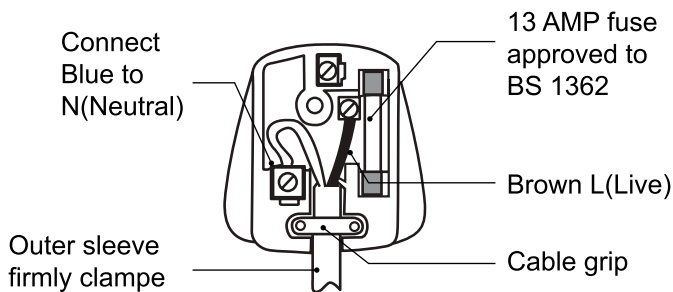

WARNING! Never connect live or neutral wires to the earth terminal of the plug, which is marked with E.

Only fit an approved 13 Amp BS 1363 or BS 1363/A plug and the correctly rated fuse. If in doubt, consult a qualified electrician.

If a moulded plug is fitted and has to be removed take great care in disposing of the plug and severed cable, it must be destroyed to prevent engaging into a socket.

Transportation



WARNING! Always carry the product by its hand grip.
Never use the cord for carrying the product.

1. Switch the product off and disconnect it from the power supply.
2. Always carry the product by its hand grip.
3. Protect the product from any heavy impact or strong vibrations which may occur during transportation in vehicles.
4. Secure the product to prevent it from slipping or falling over.

Storage

1. Switch the product off and disconnect it from the power supply.
2. Clean the product as described above.
3. Store the product and its accessories in a dark, dry, frost-free, well-ventilated place.
4. Always store the product in a place that is inaccessible to children. The ideal storage temperature is between 10 °C and 30 °C.
5. We recommend using the original package for storage or covering the product with a suitable cloth or enclosure to protect it against dust.

Recycling and disposal



Waste electrical products should not be disposed of with household waste. Please recycle where facilities exist. Check with your local authority or local store for recycling advice.



Guarantee

We take special care to select high quality materials and use manufacturing techniques that allow us to create products incorporating design and durability. This product (**Erbauer** Multi Tool) has a manufacturer's guarantee of 3 years against manufacturing defects, from the date of purchase (if bought in store) or date of delivery (if bought online), at no additional cost.

To make a claim under this guarantee, you must present your proof of purchase (such as a sales receipt, purchase invoice or other evidence admissible under applicable law), please keep your proof of purchase in a safe place. For this guarantee to apply, the product you purchased must be new, it will not apply to second hand or display products. Unless stated otherwise by applicable law, any replacement product issued under this guarantee will only be guaranteed until expiry of the original guarantee period.

This guarantee covers product failures and malfunctions provided the product was used for the purpose for which it is intended and subject to installation, cleaning, care and maintenance in accordance with the information contained in these terms and conditions, in the user manual and standard practice, provided that standard practice does not conflict with the user manual.

This guarantee does not cover defects and damage caused by normal wear and tear or damage that could be the result of improper use, faulty installation or assembly, neglect, accident, misuse, or modification of the product. Unless stated otherwise by applicable law, this guarantee will not cover, in any case, ancillary costs (shipping, movement, costs of uninstalling and reinstalling, labour etc), or direct and indirect damage.

This guarantee does not cover defects and damage caused by or resulting from:

- Normal wear and tear
- Overload, misuse or neglect
- Repairs attempted by anyone other than an authorised agent
- Cosmetic damage
- Damage caused by foreign objects, substances or accidents
- Accidental damage or modification
- Failure to follow manufacturer's guidelines
- Loss of use of the goods

If the product is defective, we will, within a reasonable time, repair or replace it.

Rights under this guarantee are enforceable in the country in which you purchased this product. Guarantee related queries should be addressed to the store you purchased this product from.

The guarantee is in addition to and does not affect your statutory rights.



Declaration of conformity



(EN) EU DECLARATION OF CONFORMITY
(FR) DÉCLARATION UE DE CONFORMITÉ
(PL) DEKLARACJA ZGODNOŚCI UE
(RO) DECLARAȚIA DE CONFORMITATE UE
(ES) DECLARACIÓN UE DE CONFORMIDAD
(PT) DECLARAÇÃO DE CONFORMIDADE UE

Product/ Produit/ Produkt/Produsul/Producto/Producto

- MULTI TOOL / OUTIL MULTIFONCTION / URZĄDZENIE WIELOFUNKCYJNE / UNEALTĂ MULTIFUNCȚIONALĂ / MULTIHERRAMIENTA / FERRAMENTA MULTIFUNÇÕES
- EMT300-QC
- SN: 000001-999999

Name and address of the manufacturer or his authorised representative:

Nom et adresse du fabricant ou de son mandataire:

Nazwa i adres producenta lub jego upoważnionego przedstawiciela:

Denumirea și adresa producătorului sau a reprezentantului său autorizat:

Nombre y dirección del fabricante o de su representante autorizado:

Nome e endereço do fabricante ou do respetivo mandatário:

Kingfisher International Products B.V.,
Rapenburgerstraat 175E,
1011 VM Amsterdam,
The Netherlands

This declaration of conformity is issued under the sole responsibility of the manufacturer.

La présente déclaration de conformité est établie sous la seule responsabilité du fabricant.

Niniejsza deklaracja zgodności wydana zostaje na wyłączną odpowiedzialność producenta.

Prezenta declarație de conformitate este emisă pe răspunderea exclusivă a producătorului.

La presente declaración de conformidad se expide bajo la exclusiva responsabilidad del fabricante.

A presente declaração de conformidade é emitida sob a exclusiva responsabilidade do fabricante.

Object of the declaration/Objet de la declaration/Przedmiot deklaracji/Obiectul declarației/Objeto de la declaración/Objeto da declaração

Product/Produit/Produkt/Produsul/Producto/Producto

Model/Modèle/Model/
Modelul/Modelo/Modelo

EAN

MULTI TOOL
OUTIL MULTIFONCTION
URZĄDZENIE WIELOFUNKCYJNE
UNEALTĂ MULTIFUNCȚIONALĂ
MULTIHERRAMIENTA
FERRAMENTA MULTIFUNÇÕES

EMT300-QC

3663602795100 (UK)
3663602795117 (EU)

The object of the declaration described above is in conformity with the relevant Union harmonisation legislation:

L'objet de la déclaration décrit ci-dessus est conforme à la législation d'harmonisation de l'Union applicable:

Wymieniony powyżej przedmiot niniejszej deklaracji jest zgodny z odpowiednimi wymaganiami unijnego prawodawstwa harmonizacyjnego:

Obiectul declarației descris mai sus este în conformitate cu legislația relevantă de armonizare a Uniunii:

El objeto de la declaración descrita anteriormente es conforme con la legislación de armonización pertinente de la Unión:

O objeto da declaração acima descrito está em conformidade com a legislação de harmonização da União aplicável:

2006/42/EC as amended

Machinery Directive

2014/30/EU as amended

Directive Electromagnetic compatibility

2011/65/EU as amended

Directive Restriction of the use of certain hazardous substances in electrical and electronic equipment

2006/42/CE en tant que directive modifiée sur les machines

2014/30 / UE telle que modifiée Directive Compatibilité électromagnétique

Directive 2011/65 / UE telle que modifiée Limitation de l'utilisation de certaines substances dangereuses dans les équipements électriques et électroniques

2006/42/WE w zmienionej dyrektywie maszynowej

2014/30 / UE ze zmianami Dyrektywa Kompatybilność elektromagnetyczna

2011/65 / UE ze zmianami Dyrektywa Ograniczenie stosowania niektórych niebezpiecznych substancji w sprzęcie elektrycznym i elektronicznym

2006/42/CE, astfel a fost modificată Directiva privind echipamentele

2014/30/UE, astfel a fost modificată Directiva privind compatibilitatea electromagnetică

2011/65/UE, astfel a fost modificată Directiva privind limitarea utilizării anumitor substanțe periculoase în echipamentele electrice și electronice

Directiva sobre maquinaria modificada 2006/42/CE

2014/30/UE modificada Directiva Compatibilidad electromagnética

2011/65/UE modificada Directiva Restricción del uso de determinadas sustancias peligrosas en equipos eléctricos y electrónicos

2006/42/CE como diretiva de máquinas alteradas

2014/30/UE como alteração da compatibilidade eletromagnética

2011/65/UE como restrição diretiva alterada da utilização de certas substâncias perigosas em equipamentos elétricos e eletrônicos

References to the relevant harmonised standards used or references to the other technical specifications in relation to which conformity is declared:

Références des normes harmonisées pertinentes appliquées, y compris la date de celles-ci, ou des autres spécifications techniques, y compris la date de celles-ci, par rapport auxquelles la conformité est déclarée:

Odwolania do odnośnych norm zharmonizowanych, które zastosowano, wraz z datą normy, lub do innych specyfikacji technicznych, wraz z datą specyfikacji, w odniesieniu do których deklarowana jest zgodność:

Trimiteri la standardele armonizate relevante folosite, inclusiv data standardului, sau trimiteri la celelalte specificații tehnice, inclusiv data specificațiilor, în legătură cu care se declară conformitatea:

Referencias a las normas armonizadas pertinentes utilizadas, incluidas las fechas de las normas, o referencias a las otras especificaciones técnicas, incluidas las fechas de las especificaciones, respecto a las cuales se declara la conformidad:

Referências às normas harmonizadas aplicáveis utilizadas, incluindo a data da norma, ou às outras especificações técnicas, incluindo a data da especificação, em relação às quais é declarada a conformidade:

EN 62841-1:2015

EN 62841-2-4:2014

EN 55014-1:2017+A11:2020

EN IEC 55014-1:2021

EN 55014-2:2015

EN IEC 55014-2:2021

EN IEC 61000-3-2:2019

EN IEC 61000-3-2:2019+A1:2021

EN 61000-3-3:2013+A1:2019

Authorized Signatory and technical file holder/ Signataire et responsable de la documentation technique autorisé/ Podmiot uprawniony do wystawienia i adres przechowywania dokumentacji technicznej/ Semnatar autorizat și deținătorul dosarului tehnic/ Firmante autorizado y titular del expediente técnico/Signatário autorizado e detentor da ficha técnica:

Kingfisher International Products B.V.,
Rapenburgerstraat 175E,
1011 VM Amsterdam,
The Netherlands



David Awe
Group Quality Director

On: 19/07/2021

**UK
CA**
(UK) DECLARATION OF CONFORMITY

Product

- MULTI TOOL
- EMT300-QC
- Serial number:000001-999999

Name and address of the manufacturer or his authorised representative:

Kingfisher International Products Limited
3 Sheldon Square
London W2 6PX
United Kingdom

This declaration of conformity is issued under the sole responsibility of the manufacturer.

Object of the declaration

Product	Model	EAN
MULTI TOOL	EMT300-QC	3663602795100

The object of the declaration described above is in conformity with the relevant legislation:

Supply of Machinery (Safety) Regulations 2008 as amended
Electromagnetic Compatibility Regulations 2016 as amended
The Restriction of the use of Certain Hazardous Substances in Electrical and Electronic Equipment Regulations 2012 as amended

References to the relevant designated standards used or references to the other technical specifications in relation to which conformity is declared:

EN 62841-1:2015
EN 62841-2-4:2014
BS EN 62841-1:2015
BS EN 62841-2-4:2014
EN 55014-1:2017+A11:2020
EN IEC 55014-1:2021
EN 55014-2:2015
EN IEC 55014-2:2021
EN IEC 61000-3-2:2019
EN IEC 61000-3-2:2019+A1:2021
EN 61000-3-3:2013+A1:2019
BS EN 55014-1:2017+A11:2020
BS EN IEC 55014-1:2021
BS EN 55014-2:2015
BS EN IEC 55014-2:2021
BS EN IEC 61000-3-2:2019
BS EN IEC 61000-3-2:2019+A1:2021
BS EN 61000-3-3:2013+A1:2019

Authorized Signatory and technical file holder:

Kingfisher International Products Limited
3 Sheldon Square
London W2 6PX
United Kingdom



David Awe
Group Quality Director

On [19/07/2021]



Manufacturer • Fabricant • Producent • Producător • Fabricante:

UK manufacturer:

Kingfisher International Products Limited
3 Sheldon Square London W2 6PX
United Kingdom
www.kingfisher.com/products

EU manufacturer:

Kingfisher International Products B.V.
Rapenburgerstraat 175E
1011 VM Amsterdam
The Netherlands

www.diy.com | www.screwfix.com | www.screwfix.ie

To view instruction manuals online,
visit www.kingfisher.com/products

Customer Helpline:

UK 03301248111 erbauer@powertoolservicing.co.uk

Eire 0035312479977 erbauer@powertoolservicing.co.uk