



40cm (16") Petrol Chainsaw

WEPCS16

1938316001

en - Original Instructions

ASSEMBLY REQUIRED

Save these instructions

Sales & Support: 01793 333212

Before use please read & understand this manual; paying particular attention to the safety instructions before use.

Incorrect use of the product could put the operator or machine in danger.

Whilst every effort has been made to ensure the accuracy of information contained in this manual, our policy of continuous improvement determines the right to make modifications without prior warning.

Images are used for illustration purposes only.



INSTRUCTION MANUAL



25 Oct 2021

Copyright Notice

Copyright © Handy Distribution

Permission is granted to reproduce this publication for personal & educational use only.

Commercial copying, redistribution, hiring or lending is prohibited.

No part of this publication may be stored in a retrieval system or transmitted in any other form or means without written permission from Handy Distribution.

In all cases this copyright notice must remain intact.

CONTENTS

INTENDED USE
SAFETY INSTRUCTIONS
SPECIFICATIONS
KNOW YOUR MACHINE
ASSEMBLY
OPERATION
MAINTENANCE, CLEANING & STORAGE
TROUBLE SHOOTING
PARTS DIAGRAM & LIST
DECLARATION OF CONFORMITY
WARRANTY

ASSEMBLY IS REQUIRED

This product requires assembly before use. See the “Assembly” section for instructions. Please check that all parts required for the assembly of this product are included. If for any reason you believe a part for the assembly is missing or damaged, please contact us.

INTENDED USE

This chainsaw is only designed for cutting of branches, trunks or timber beams up to a diameter according the guide bar length. It is only allowed to cut wood. Every other use of the machine is a not intended use. Furthermore, a professional use for tree services is strictly forbidden.

During use of the chainsaw the user has to arrange for personal protective equipment (PPE) according to the manual and also to the named pictograms on the chainsaw. Parts of the intended use are also the details in the manual regarding safety warnings and references for use/maintenance. People/Users who work with the chainsaw or undertake maintenances on it, must be familiar with the manual. Only assemble onto the chainsaw, the manufacturers original or approved spare parts as well as the allowed combinations of guide bar/saw chain as named in the manual.

The user and not the manufacturer are liable for any accident which results from a combination of incorrect intended use or an incorrect construction on the machine.

The chainsaw is only intended for use outdoors.

Please read this entire manual prior to operating the equipment. It instructs you how to safely and easily set up, operate and maintain your machine. Please be sure that you, and any other persons who will operate the machine, carefully follow the recommended safety practices, at all times. Failure to do so could result in personal injury or property damage.

TO THE OWNER

All information in this manual is relative to the most recent product information available at the time of printing. Review this manual frequently to familiarise yourself with the machine, its features and operation. Please be aware that this Instruction Manual may cover a range of product specifications for various models. Characteristics and features discussed and/or illustrated in this manual may not be applicable or exact to all models.

We reserve the right to change product specifications, design and equipment without notice and without incurring obligation. If you have any problems or questions concerning the machine, phone your local authorised service dealer or ourselves. Throughout this manual, all references to *right* and *left* side of the machine are observed from the operating position.



INSTRUCTION MANUAL

RISIDUAL RISKS

Even with the intended use of the appliance there is always a residual risk, which cannot be prevented. According to the type and construction of the appliance the following potential hazards might apply:

- Contact with exposed saw teeth of the saw chain (cutting hazards).
- Access to the rotating saw chain (cutting hazards).
- Unforeseen, abrupt movement of the guide bar (cutting hazards).
- Flung out of parts from the saw chain (Cutting / injection hazards).
- Flung out of parts of the work piece.
- Inhalation of wood particles.
- Skin contact with chain oil.
- Loss of hearing, if required ear protection not used during work.

INSPECT YOUR LOG

Make sure there are no nails or foreign objects in logs to be cut.

















WARNING

The equipment is to be used only for its prescribed purpose. Any other use is deemed to be a case of misuse. The user/operator and not the manufacturer will be liable for any damage or injuries of any kind caused as a result of this.





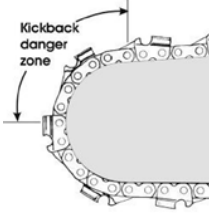

Please note that our equipment has **NOT** been designed for use in commercial, trade or industrial applications. Our warranty will be 90 days from the original date of sale for commercial, trade or industrial businesses or for equivalent purposes.

SAFETY INSTRUCTIONS

Read and understand the owner's manual and labels affixed to the machine. Learn its application and limitations as well as the specific potential hazards. Retain these instructions for future reference. The operator is responsible for following the warnings & instructions in this manual and on the product.

	<p>Read & understand operator's manual before using the machine. Failure to follow instructions could result in death or serious injury. Please keep in a safe place for future reference.</p>		<p>Whenever the machine is in use, safety glasses/goggles must be worn to safeguard against flying objects. Hearing protection must also be used to protect the operators hearing. If the operator is working in an area where there is a risk of falling objects, a safety helmet must also be worn.</p>
	<p>DANGER Keep all bystanders & animals at least 15 metres away from the machine during operation. If approached, stop the machine immediately. DANGER — THROWN DEBRIS Remove objects that can be thrown by the machine in any direction. Wear safety glasses.</p>	 	<p>Always wear gloves to protect your hands. Wear foot protection or sensible shoes when using the machine SHARP ROTATING CHAIN</p>
	<p>Risk of Carbon Monoxide Poisoning. Ensure working area is correctly ventilated.</p>		<p>When repairing, servicing or undertaking general maintenance and cleaning, please remove the spark plug cap from the spark plug.</p>
	<p>Fire Risk Fire and its vapors are extremely flammable & explosive. Fire or explosion can cause severe burns or death.</p>		<p>Do not expose to rain or damp conditions.</p>
	<p>No smoking</p>		<p>Do not use near a flame, or sparks</p>
	<p>Hot Surface. Running engines produce heat. Engine parts, especially the exhaust, become extremely hot. Severe thermal burns can occur on contact</p>		<p>Correct direction of cutting teeth</p>
	<p>The chainsaw is supplied with a KICKBACK chain, however sometimes kick back can occur, so always hold the unit firmly in two hands. The Kickback danger zone on your chainsaw is the upper part of the nose of the guide bar. Never saw with the danger zone, which poses a significant risk for kickback.</p>	 	<p>Do not use chainsaw one-handed. Always use chainsaw two-handed</p>

INSTRUCTION MANUAL

	Keep guards in place and in working order. Replace damaged, missing or failed parts before using it.		Safety alert symbol. Used to alert you to potential personal injury hazards. Obey all safety messages that follow this symbol to avoid possible injury.
 DANGER	Indicates an imminently hazardous situation which, if not avoided, will result in serious injury	 WARNING	Indicates a potentially hazardous situation which, if not avoided, could result in serious injury
 CAUTION	Indicates a potentially hazardous situation which, if not avoided, may result in minor or moderate injury.	CAUTION	Used without the safety alert symbol indicates a potentially hazardous situation which, if not avoided, may result in property damage.
	CE Marking - the product meets demand and regulations set by the EU		Noise Level - See label on machine

GENERAL SAFETY RULES



WARNING

Before you put the machine into operation, you must read this instruction manual.

When using this machine, observe the following safety instructions to exclude the risk of personal injury or material damage. Please also observe the special safety instructions in the respective chapters. Where applicable, follow the legal directives or regulations for the prevention of accidents in relation to the use of this machine.

When using petrol tools, basic safety precautions, including the following, should always be followed to reduce the risk of serious personal injury and/or damage to the unit.

TRAINING



The operator must receive proper training in the use, adjustment and operation of the machine, including prohibited operations.

1. Read the instructions carefully. Be familiar with the controls & proper use of the equipment. Spend time to familiarise yourself with your machine before each use.
2. Never allow children or people unfamiliar with these instructions to use the machine. Local regulations can restrict the operator age.
3. This machine is not intended for use by persons (including children) with reduced physical, sensory or mental capabilities, or lack of experience and knowledge, unless they have been given supervision or instruction concerning use of the machine by a person responsible for their safety.
4. Never work while people, especially children, or pets are nearby.
5. The operator or user is responsible for accidents or hazards occurring to other people or their property.

GENERAL OPERATION

1. Thoroughly inspect the area where the equipment is to be used. Remove all stones, sticks, wire, bones, toys and other foreign objects, which could be tripped over or picked up and thrown by the chainsaw. Thrown objects can cause serious personal injury.
2. Plan your cutting pattern to avoid discharge of material toward roads, pathways, bystanders and the like. Also, avoid discharging material against a wall or obstruction, which may cause discharged material to ricochet back toward the operator.
3. To help avoid chain contact or a thrown object injury, stay in operator zone behind handles and keep children, bystanders, helpers and pets at least 15 metres from chainsaw while it is in operation. Stop machine if anyone enters area.

4. Always wear safety glasses or safety goggles during operation and while performing an adjustment or repair to protect your eyes. Thrown objects which ricochet can cause serious injury to the eyes.
5. Wear sturdy, protective rough-soled work shoes and close-fitting trousers and shirts. Shirts and trousers that cover the arms and legs and steel-toed shoes are recommended. Never operate this machine in bare feet, sandals, slippery or light-weight (e.g. canvas) shoes.
6. Do not put hands or feet near or under rotating parts. When maintaining the machine, ensure the engine is off and spark plug cap removed from the spark plug. Always wear safety gloves when touching the saw chain.
7. Never operate the chainsaw without proper shields, guards, chain brake or other safety devices in place and working.
8. Never operate the chainsaw with damaged safety devices. Failure to do so, can result in personal injury.
9. Many injuries occur as a result of a fall caused by slipping or tripping. Do not hold on to the chainsaw if you are falling; release the handle immediately.
10. Do not operate the chainsaw while under the influence of alcohol or drugs.
11. The trigger and chain brake are safety devices. Never attempt to bypass its operation. Doing so makes the safety device inoperative and may result in personal injury through contact with the chain.
12. Never operate the chainsaw in wet conditions. Always be sure of your footing. A slip or fall can cause serious personal injury. If you feel you are losing your footing, release the trigger and set the chain brake immediately and the chain will stop rotating almost immediately.
13. Operate only in daylight or good artificial light. Walk, never run with the chainsaw in your hand.
14. If the machine starts to vibrate abnormally, stop and turn off the engine. Check immediately for the cause. Vibration is generally a warning of trouble.
15. Never operate with damaged safety devices. Failure to do so can result in personal injury.
16. Only use parts and accessories made for this machine by the manufacturer. Failure to do so can result in personal injury.
17. If situations occur which are not covered in this manual, use care and good judgement. Contact your nearest Approved Service Dealer for assistance

SLOPE OPERATION

Slopes are a major factor related to slip and fall accidents, which can result in severe injury. Operation on slopes requires extra caution. If you feel uneasy on a slope, do not cut on it.

Do:

1. Exercise extreme caution when changing direction on slopes.
2. Watch for holes, ruts, rocks, hidden objects, or bumps which can cause you to slip or trip. Tall grass can hide obstacles.
3. Always be sure of your footing. A slip or fall can cause serious personal injury. If you feel you are losing your balance, release the trigger immediately and set the chain brake.

Do Not:

1. Do not cut near drop-offs, ditches or embankments, you could lose your footing or balance.
2. Do not cut on wet ground. Unstable footing could cause slipping.

CHILDREN

Tragic accidents can occur if the operator is not alert to the presence of children. Children are often attracted to the chainsaw and the cutting activity. They do not understand the dangers. Never assume that children will remain where you last saw them.

1. Keep children out of the cutting area and under care of a responsible adult other than the operator.
2. Be alert and turn the chainsaw off if a child enters the area.
3. Before and while moving backwards, look behind and down for small children.
4. Keep children away from hot or running machines.
5. Never allow children under 16 years of age to operate this machine. Children 16 and over should read and understand the instructions and safe operation practices in this manual and on the machine and be trained and supervised by an adult.



INSTRUCTION MANUAL

SERVICE

General Service:

1. Never run the engine in a poorly ventilated area.
2. Before cleaning, repairing, or inspecting, make sure all moving parts have stopped. Disconnect the spark plug cap from the spark plug to prevent unintended starting.
3. Check the bar, chain and sprockets at frequent intervals for proper tightness. Also, visually inspect spindle for damage. Replace with the original equipment manufacturer's (O.E.M.) parts only, listed in this manual. "Use of parts which do not meet the original equipment specifications may lead to improper performance and compromise safety!"
4. Keep all nuts, bolts, and screws tight to be sure the equipment is in safe working condition.
5. Never tamper with safety devices. Check the correct operation regularly.
6. After striking a foreign object, stop the motor, disconnect the spark plug cap from the spark plug. Thoroughly inspect the chainsaw for any damage. Repair the damage before starting and operating the chainsaw.
7. Chainsaw components, guards and shields are subject to wear and damage which could expose moving parts or allow objects to be thrown. For safety protection, frequently check components and replace immediately with original equipment manufacturers (O.E.M.) parts only, listed in this manual. "Use of parts which do not meet the original equipment specifications may lead to improper performance and compromise safety!"
8. Maintain or replace safety and instruction labels, as necessary.
9. Observe proper disposal laws and regulations. Improper disposal of fluids and materials can harm the environment.

DO NOT MODIFY THE ENGINE

To avoid serious injury or death, do not modify the engine in any way. The engine has been tested to meet stringent legislation tests.

PERSONAL SAFETY

1. This machine is not intended for use by persons (including children) with reduced physical, sensory or mental capabilities, or lack of experience and knowledge, unless they have been given supervision or instruction concerning use of the machine by a person responsible for their safety.
2. Children should be supervised to ensure that they do not use or play with the machine.
3. Stay alert, watch what you are doing and use common sense when operating this machine.
4. Do not use this machine while you are tired, ill or under the influence of drugs, alcohol, or medication. A moment of inattention while operating this machine can cause you to lose control & may result in serious personal injury.
5. Use safety equipment. Always wear eye protection. Safety equipment such as a dust mask, non-skid safety shoes, hard hat, sturdy gardening gloves, or hearing protection used for appropriate conditions will reduce personal injuries.
6. Dress properly. Do not wear loose clothing or jewellery. Keep your hair, clothing & gloves away from moving parts. Loose clothes, jewellery or long hair can be caught in moving parts.
7. Prolonged use of the machine may lead to disorders of blood circulation in hands caused by vibration. These effects can be worsened by low ambient temperatures and/or by gripping the handgrips excessively tightly. Period of use you can extend with appropriate gloves or regular breaks. Take frequent work breaks. Limit the amount of exposure per day.

ADDITIONAL SAFETY POINTS

1. Keep all parts of the body away from the saw chain when the chainsaw is operating. Before you start the chainsaw, make sure the saw chain is not contacting anything. A moment of inattention while operating chainsaws may cause entanglement of your clothing or body with the saw chain.
2. Always hold the chainsaw with your right hand on the rear handle and your left hand on the front handle. Holding the chainsaw with a reversed hand configuration increases the risk of personal injury and should never be done.
3. Wear safety glasses and hearing protection. Further protective equipment for head, hands, legs and feet is recommended. Adequate protective clothing will reduce personal injury by flying debris or accidental contact with the saw chain.
4. Do not operate a chainsaw in a tree. Operation of a chainsaw while up in a tree may result in personal

- injury.
5. Always keep proper footing and operate the chainsaw only when standing on fixed, secure and level surface. Slippery or unstable surfaces such as ladders may cause a loss of balance or control of the chainsaw.
 6. When cutting a tree limb that is under tension be alert for spring back. When the tension in the wood fibre is released, the spring-loaded limb may strike the operator and/or throw the chainsaw out of control.
 7. Use extreme caution when cutting brush and saplings. The slender material may catch the saw chain and be whipped toward you or pull you off balance.
 8. Carry the chainsaw by the front handle with the chain brake on, chainsaw switched off and the saw chain away from your body. When transporting or storing the chainsaw always fit the guide bar cover. Proper handling of the chainsaw will reduce the likelihood of accidental contact with the moving saw chain.
 9. Follow instructions for lubricating, chain tensioning and changing accessories. Improperly tensioned or lubricated chain may either break or increase the chance for kickback.
 10. Keep handles dry, clean, and free from oil and grease. Greasy, oily handles are slippery causing loss of control.
 11. Cut wood only. Do not use the chainsaw for purposes not intended. For example: do not use the chainsaw for cutting plastic, masonry, or non-wood building materials. Use of the chainsaw for operations different than intended could result in a hazardous situation.

CAUSES AND OPERATOR PREVENTION OF KICKBACK:

Kickback may occur when the nose or tip of the guide bar touches an object, or when the wood closes in and pinches the saw chain in the cut.

Tip contact in some cases may cause a sudden reverse reaction, kicking the guide bar up and back towards the operator. Pinching the saw chain along the top of the guide bar may push the guide bar rapidly back towards the operator.

Either of these reactions may cause you to lose control of the chainsaw which could result in serious personal injury. Do not rely exclusively upon the safety devices built into your chainsaw. As a chainsaw user, you should take several steps to keep your cutting jobs free from accident or injury.

Kickback is the result of tool misuse and/or incorrect operating procedures or conditions and can be avoided by taking proper precautions as given below:

- Keep a good grip on the saw with both hands, the right hand on the rear handle and trigger, and the left hand on the front handle, when the engine is running. Use a firm grip with thumbs and fingers encircling the chainsaw handles. A firm grip will help you reduce kickback and maintain control of the saw. Do not let go.



- Make certain that the area in which you're cutting is free from obstructions. Do not let the nose of the guide bar contact a log, branch, or any other obstruction which could be hit while you are operating the chainsaw.

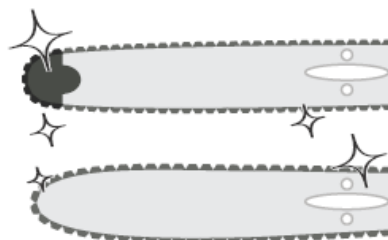

- Cut at high engine speeds.
- Do not overreach and do not cut above shoulder height. This helps prevent unintended tip contact and enables better control of the chainsaw in unexpected situations.



INSTRUCTION MANUAL



- Only use replacement bars and chains specified by the manufacturer. Incorrect replacement bars and chains may cause chain breakage and/or kickback.
- Follow the manufacturer's sharpening and maintenance instructions for the saw chain. Decreasing the depth gauge height can lead to increased kickback.

PETROL TOOL USE AND CARE



WARNING!

Petrol is highly flammable and explosive.

1. Store petrol in containers specifically designed for this purpose.
2. Refuel outdoors only and do not smoke while refueling.
3. Add fuel before starting the engine. Never remove the cap of the tank or add petrol while the engine is running or when the engine is hot.
4. If petrol is spilled, do not attempt to start the engine but move the machine away from the area of spillage and avoid creating any source of ignition until petrol vapors have dissipated.
5. Replace fuel tank & container caps securely.
6. Do not operate the engine in a confined space where dangerous carbon monoxide can collect.
7. Do not force the machine. Use the correct machine for your application. The correct machine will do the job better and safer at the rate for which it was designed.
8. Do not use the machine if the on/off switch does not work to turn the machine off. Any machine that cannot be controlled with the on/off switch is dangerous and must be repaired.
9. Turn machine off completely before making any adjustments, changing accessories, or storing. Such preventive safety measures reduce the risks of starting the petrol tool accidentally.
10. Store idle machines out of the reach of children and do not allow persons unfamiliar with the machine or these instructions to operate. Petrol machines are dangerous in the hands of untrained users.
11. Maintain your machine. Check for misalignment or binding of moving parts, breakage of parts & any other condition that may affect the operation. If damaged, have the machine inspected by an Approved Webb Service Dealer immediately. Many accidents are caused by poorly maintained machines.
12. Use the machine, accessories and tool bits etc., in accordance with these instructions and in the manner intended for the particular type of petrol machine, taking into account the working conditions and the work to be performed. Use of the machine for operations different from intended could result in a hazardous situation.

PERSON PROTECTION

1. In case of any injury always proceed in accordance with the principles of first aid.
2. If someone is cut, cover the wound with a clean cloth & press hard to stop the flow of blood.
3. Do not let petrol or oil come in contact with your skin. Keep petrol and oil away from the eyes. If petrol or oil come into contact with the eyes, wash them immediately with clean water. If irritation is still present, see a doctor immediately.
4. Individuals with poor circulation who are exposed to excessive vibration may experience injury to blood vessels or the nervous system. Vibration may cause the following symptoms to occur in the fingers, hands or wrists: numbness, tingling, pain, stabbing sensation, alteration of skin colour or of the skin. If any of

these symptoms occur, see a doctor.

Put safety first in the case of fire:

5. If fire comes from the engine or smoke appears from anywhere other than the exhaust vent, at first distance yourself from the product to ensure your physical safety.
6. Use a dry powder fire extinguisher on the fire to prevent it from spreading.
7. A panicked reaction could result in the fire and other damage becoming more extensive.

SPECIFICATIONS

Model	WEPCS16
Product Number	1938316001
Engine Displacement	45.2 cm ³
Maximum Engine Power	1.7 kW
Fuel Ratio (Unleaded Petrol:2 Stroke Synthetic or Semi-Synthetic Oil)	40:1
Fuel Tank Capacity	0.6 L
Oil Tank Capacity	0.26 L
Carburettor	Diaphragm
Idling Speed Range	3000±400 min ⁻¹
Maximum Speed	12000 min ⁻¹
Spark Plug	TORCH L7RTC / CHAMPION RCJ7Y / BOSCH L8RTF / DENSO W22MPR / NGK BPMR7A
Cutting Bar Length	16" (40 cm)
Chain Pitch	0.325"
Chain Links	66
Guide Bar Groove	0.058"/1.5 mm
Sound Pressure Level L _{PA}	97.5 dB(A) - K _{PA} = 3.0 dB(A)
Sound Power Level L _{WA}	111 dB(A) - K _{WA} = 3.0 dB(A)
Declared Sound Power Level L _{WAd}	114 dB(A)
Vibration a _{hv} :	Front Handle 7.65 m/s ² Rear Handle 8.49 m/s ² K= 1.5 m/s ²

The manufacturer reserves the right to change the product specification and livery according to continued product improvements.





INSTRUCTION MANUAL





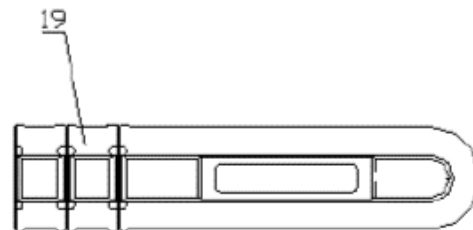
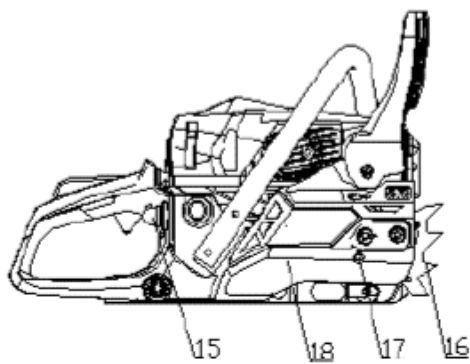
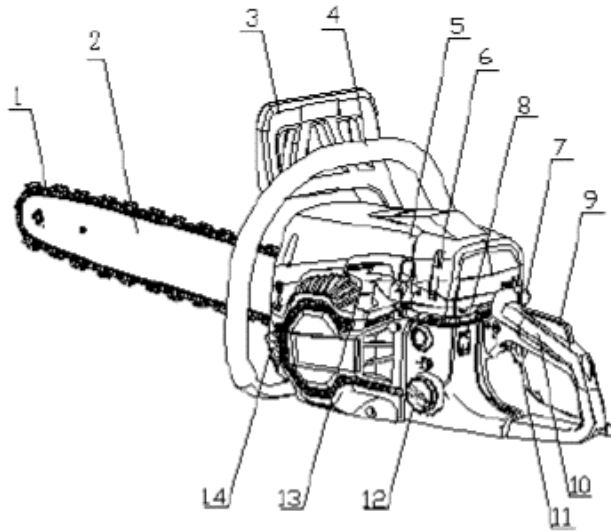



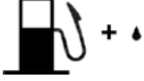

KNOW YOUR MACHINE

1. Saw Chain	2. Guide Bar
3. Chain Brake	4. Front Handle
5. Cylinder Shield	6. Lock Lever
7. Choke Knob	8. On/Off Switch
9. Throttle Trigger Lock-Out	10. Rear Handle
11. Throttle Trigger	12. Fuel Tank Cap
13. Recoil Handle	14. Oil Tank Cap
15. Primer Bulb	16. Spiked Bumper
17. Chain Tensioner	18. Clutch Cover
19. Guide Bar Cover	



MACHINE SYMBOLS

For safe operation and maintenance, symbols are moulded into various components of the machine.

	<p>The port to refuel the engine with 40:1 fuel mixture. Position: Near the fuel cap</p>
	<p>The port to fill with chainsaw oil, to lubricate cutting chain. Position: near the oil cap</p>
	<p>Engine on/off switch. Pressing the switch to the (O) position, immediately the engine stops. Pressing the switch to the (I) position, engines the engine for the starting procedure. (O) and (I) are shown on switch button. Position: left side of the rear handle</p>
	<p>Operate the choke knob. Pull out the choke knob to close the choke for a cold start. Push in the choke knob to open the choke for a warm start. Position: right side of the rear handle.</p>
	<p>Adjust the oil pump. Turn screw head anti-clockwise to increase oil flow. Turn clockwise to decrease oil flow. Position: Bottom of the rear handle</p>
	<p>Fuel mixture screw (H) = High-speed (L) = Low-speed (T) = Idle speed Position: Upper left of the rear handle</p>
	<p>Indicates the chain brake is released (white arrow) and activated (black arrow). Position: Front handle guard</p>
	<p>Indicates the direction of the saw chain installation. Position: Front of the chain cover</p>
	<p>Guaranteed sound power level for this equipment.</p>
	<p>Engine manual start.</p>



INSTRUCTION MANUAL

ASSEMBLY

Remove the machine and contents from the carton. Be sure the carton is empty before discarding.

If you require assistance with regards to the contents or operation of the machine, please contact us:

Tel: 01793 333212

Email: customerservice@webbgardenpower.co.uk

**Opening hours weekdays: February to October 8:00am - 5:00pm / November to January 8:30am - 5:00pm
(Closed Bank Holidays)**

IMPORTANT INFORMATION

NOTE: This product is a 2-stroke engine powered machine.

The engine MUST be filled with recommended 2-stroke semi-synthetic or synthetic oil and unleaded petrol BEFORE starting. Fresh unleaded petrol must be used in this unit. The fuel and oil must be mixed at a ratio of 40:1.



WARNING

Stop the engine and unplug the spark plug before any repairs or maintenance operations.

DO NOT attempt to start this machine without it first being FULLY assembled.

DO NOT attempt to start this machine without the recommended 2-stroke semi-synthetic or synthetic oil and unleaded petrol BEFORE starting. Fresh unleaded petrol must be used in this unit. The fuel and oil must be mixed at a ratio of 40:1.

INSTALLING GUIDE BAR & SAW CHAIN

The saw chain has very sharp edges. **Use protective gloves for safety.** Make sure the engine has stopped before making guide bar and saw chain adjustments.

A standard saw unit package contains the following items:

1. Power Unit
2. Saw Chain
3. Guide Bar
4. Guide Bar Cover
5. Plug Wrench
6. File

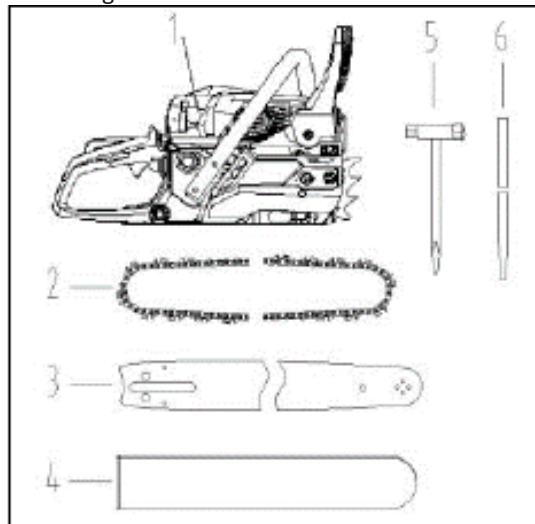

1. Pull the chain brake back towards the front handle to release the chain brake.
2. Loosen the two securing nuts holding the clutch cover to the power unit. Remove the clutch cover.
3. Fit the saw chain around the guide bar, ensuring the chain direction is correct.
4. Mount the guide bar to the power unit, looping the chain over the power unit sprocket and inserting the chain tensioner (7) into the lower hole (8) of the guide bar. Adjust the chain tension, using adjuster (9)

5. Install the clutch cover to the power unit and fasten the two securing nuts, to finger tightness.

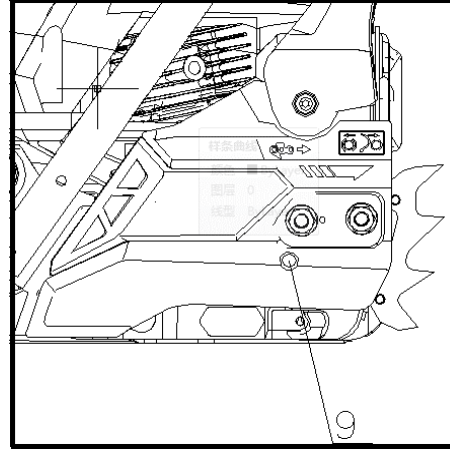
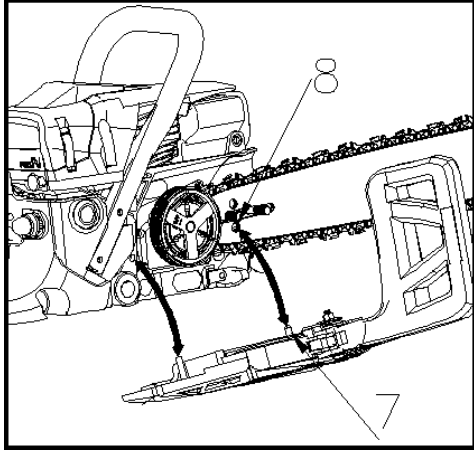

NOTE

Pay attention to the correct direction of the saw chain.

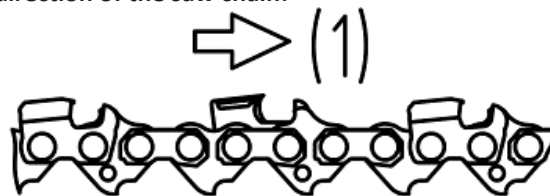

6. While holding up the tip of the bar, adjust the chain tension by turning the tensioner screw until the tie straps just touch the bottom side of the bar rail.
7. Tighten the clutch cover securing nuts securely with the bar tip held up (12 ~ 15 Nm). Then check the chain for smooth rotation and proper tension while moving it by hand (ENSURE PROTECTIVE GLOVES ARE WORN). If necessary, readjust with the chain cover loose.
8. Adjust the chain tensioner screw.
 - a. Turn anti-clockwise: Loosen the chain.
 - b. Turn clockwise: Tighten the chain.

CHAIN TENSION

Always check the chain tension before use, after the first cuts and regularly during use, approx. every 10 minutes. Upon initial operation, new chains can lengthen considerably.

The correct chain tension is reached when the chain can be raised 3-6mm from the centre of the chain bar.

This should be done, by using one hand to raise the chain against the weight of the machine. (Wear protective gloves)

Adjust the chain tensioner screw.

- a. Turn anti-clockwise: Loosen the chain.
- b. Turn clockwise: Tighten the chain.



WARNING

Cutting edges on the saw chain are extremely sharp. Always use protective gloves when handling. Always maintain proper chain tension. A loose chain will increase the risk of kickback. A loose chain may jump out of the guide bar groove, which may injure the operator and damage the chain, chain bar and drive sprocket, beyond repair.

The life of a saw chain will rely on sufficient lubrication and correct tensioning. Avoid tensioning the chain if it is hot. This will cause the chain to be over tensioned when it cools down.



INSTRUCTION MANUAL

FUEL & OIL



WARNING

YOUR MACHINE IS SUPPLIED WITHOUT ENGINE OIL OR PETROL

Operating the engine with insufficient oil, can have catastrophic consequences. Any failure caused by insufficient oil, will not be covered by the manufacturer's warranty.

READ INSTRUCTIONS CAREFULLY.



Fuel & its vapors are very flammable. Do not use or fuel the machine near a flame, sparks or while smoking. Allow the engine to cool for more than 3 minutes, before re-fueling. Never fuel the machine with engine running. Fuel the engine at least 15 metres away from your work area. Always fuel your machine outdoors.

IMPORTANT:

Fuel which is older than 30 days old can become stale and cause acid & gum deposits in the fuel system or essential carburettor components. This could result in starting issues which would not be covered by your manufacturer's warranty. Ensure that any stored petrol is clearly marked in a separate appropriate canister for a maximum of 30 days, if not mixed with a fuel additive. If the machine is not going to be used for a long period, drain the fuel tank, start the engine and drain the carburettor of any remaining fuel.

FUEL MIXTURE



THE MACHINE SHOULD USE A 40:1 UNLEADED PETROL TO TWO STROKE SYNTHETIC OR SEMI SYNTHETIC OIL MIXTURE RATIO. USE GOOD QUALITY UNLEADED FUEL ONLY WITH AN OCTANE OF 89 OR ABOVE.

Operating the engine with insufficient oil within your fuel mixture, can have catastrophic consequences. Any failure caused by insufficient oil, will not be covered by the manufacturer's warranty.

40:1 FUEL MIXTURE RATIO

Unleaded Petrol (litre)	Two Stroke Synthetic or Semi-Synthetic Oil (ml)
1	25
2	50
3	75
4	100
5	125

The mixture should be shaken prior to entering the machine fuel tank. It is recommended that you use a Fuel Mixing Bottle, to ensure the correct fuel mixture is used with your machine. We recommend **HANDY PARTS – FUEL MIXING BOTTLE (HP-120)**.

To keep fuel fresh, we recommend you use SURE-START FUEL ADDITIVE (HP-199) from Handy Parts. A fuel additive added to your fuel at the time of mixture, will help make your machine easier to start, extend the shelf life of your fuel mixture for up to two years, keeps the carburettor & engine clean, plus reduces emissions and increases fuel economy. A 250ml bottle of SURE-START FUEL ADDITIVE will treat 25 litres of fuel mix. Only use 2-stroke air cooled engine oil. **DO NOT USE** automotive or marine oil.

IMPORTANT

Ensure that any stored petrol/oil mixture is clearly marked in a separate appropriate canister for a maximum of 30 days if not mixed with a fuel additive. If the machine is not going to be used for a long period, drain the mixture from the fuel tank, start the engine and drain the carburettor of any remaining fuel. (See Maintenance for further instruction). Dispose of any unwanted 2-stroke mixture at an authorised recycling point.

FUELLING THE MACHINE

Place the machine onto a solid flat surface, ensuring the engine is not running.

1. Unscrew the fuel cap thoroughly, but do not remove it from machine.
2. Fill your fuel tank with a 40:1 Petrol: Two-stroke synthetic or semi synthetic oil mixture ratio to 80% of the fuel tank capacity (480ml).
3. Fasten the fuel tank cap securely being careful not to cross-thread and wipe up any fuel spillage around the unit. If the machine has continued leaks, the product should not be started.

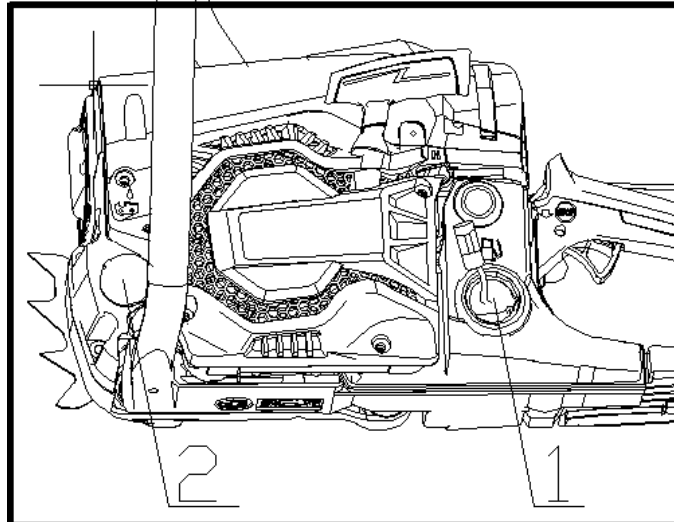

2. Oil Tank Opening

1. Fuel Tank Opening



WARNING

Fuel and its vapors are extremely flammable and explosive. Fire or explosion can cause severe burns or death.

OILING THE MACHINE (CHAINSAW OIL)

The saw chain requires constant lubrication to ensure it remains fully effective and does not overheat and blunt prematurely.

1. Unscrew the oil tank cap.
2. Fill with chainsaw oil. Do not overfill.
3. Fasten the oil tank cap securely being careful not to cross-thread and wipe up any fuel spillage around the unit. If the machine has continued leaks, the product should not be started.



INSTRUCTION MANUAL

OPERATION

ENGINE STARTING & STOPPING PROCEDURE



WARNING

Starting an engine without engine oil or fuel can seriously damage the machine. Prior to starting the engine, ensure you are wearing the appropriate safety Personal Protective Equipment for the task in hand. Before you start the engine, make sure the saw chain is not contacting anything. Make sure the chain brake is always activated before each start.

CHAIN BRAKE

The chain brake is a device which stops the chain instantaneously if the chainsaw recoils due to kickback.

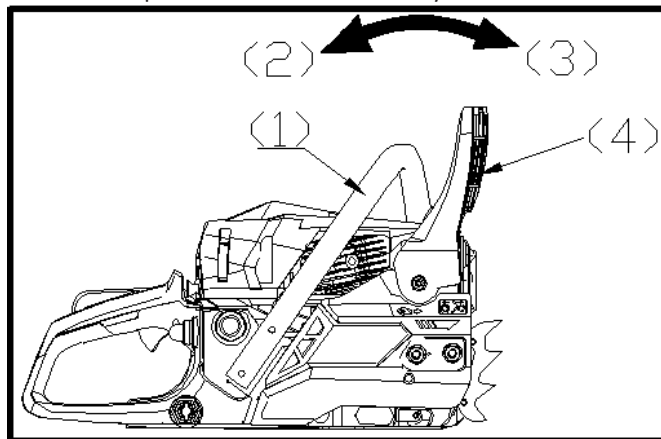

1. Front Handle - 2. Release Chain Brake - 3. Activate Chain Brake - 4. Chain Brake Lever

Normally, the chain brake is activated automatically by inertial force. It can also be activated manually by pushing the chain brake lever forwards. When the brake operates, a white cone pops up from the base of the chain brake lever. To release the chain brake, pull up the front handle guard towards the front handle till a "click" sound is heard.



WARNING

When the brake operates, release the throttle trigger to slow down the engine speed. Continuous operation with the brake engaged will generate heat from the clutch and cause a failure not covered under warranty.

Be sure to confirm the chain brake operation prior to any operation.

1. Turn off the engine.
2. Holding the chainsaw horizontally, release your hand from the front handle, hit the tip of the guide bar to a stump or a piece of wood, and confirm brake operation. Operating level varies by bar size.
3. In case the brake is not effective, contact your local approved service dealer for inspection and possible and repair.

STARTING THE ENGINE (COLD)

A "cold" start means starting it after at least 10 minutes from when it was switched off or after refuelling.

1. Switch the On/Off switch to the '1' position.
2. Push primer bulb (3) a maximum of five times or until fuel is seen in the primer bulb.
3. Pull out the choke knob (4). The choke will close and the throttle lever will set to the starting position.
4. Push the chain brake down toward the front to activate. This will stop the chain from rotating.
5. While holding the chainsaw securely on the ground, Grip the starter handle, slowly pull out the cord with your right hand until you feel some resistance (the starter pawls grip), and now quickly and powerfully pull the cord. **Never twist the starter cord around your hand.**

6. When the engine first fires (false start), turn the choke knob anti-clockwise to open the choke.
7. Repeat from Step 4 until the engine starts.
8. Pull chain brake towards the front handle to release brake. Then, allow the engine to warm up with the trigger pulled slightly.



CHOKE CLOSED
Cold Start Position



CHOKE OPEN
Warm Start or Run Position

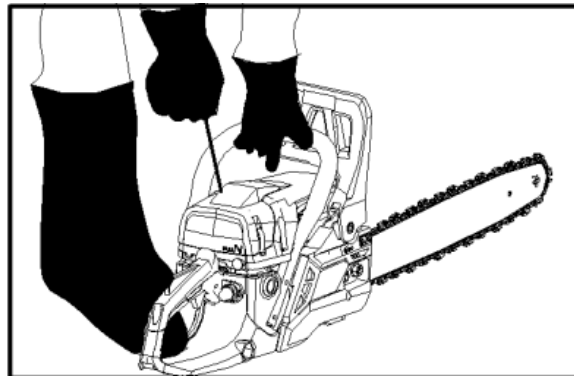
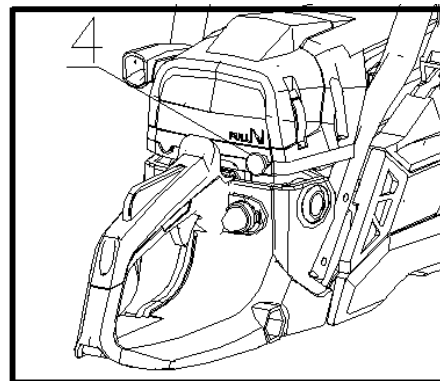
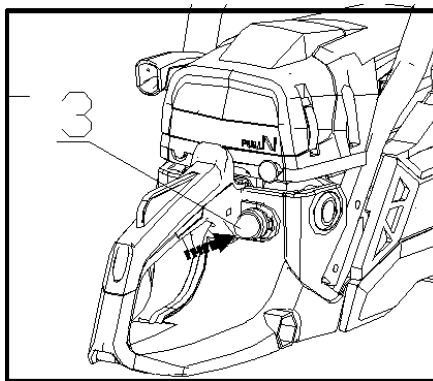

STARTING THE ENGINE (WARM/HOT)

1. Switch the On/Off switch to the 'I' position.
2. Push the chain brake down toward the front to activate. This will stop the chain from rotating.
3. While holding the chainsaw securely on the ground, Grip the starter handle, slowly pull out the cord with your right hand until you feel some resistance (the starter pawls grip), and now quickly and powerfully pull the cord. Never twist the starter cord around your hand.

ENGINE WON'T START

If the engine won't start after you have operated the starter several times when cold or hot, the engine may be flooded with excess fuel. Use the following procedure to clear and start a flooded engine.

1. Remove the spark plug, dry it, and then reinstall it.
2. Install the spark plug carefully by hand, to avoid cross-threading. After the plug is seated tighten 1/8 to 1/4 turn with socket spanner of spark plug to compress the washer.
3. Run through the engine starting procedure as described previously.

STOPPING THE ENGINE

1. Release the throttle trigger, allowing the engine to idle.
2. Switch the On/Off switch to the '0' position.



INSTRUCTION MANUAL

CHECKING CHAIN OIL SUPPLY

After starting the engine, release the chain brake and run the chain at medium speed. A correct operation of the automatic oiler can be checked by running the chainsaw and pointing the tip of the chain bar, towards a piece of cardboard or paper positioned on the ground.

CAUTION: Do not touch the ground with the chain. Ensure safety clearance of 20cm minimum. If an increasing oil pattern appears, the automatic oiler is operating correctly.

1. The chain oil flow can be changed by inserting a screwdriver in the hole on bottom of the clutch side of the base of the machine.
2. Adjust according to your work conditions.
 - Turn the shaft anti-clockwise – Increase flow.
 - Turn the shaft clockwise – Decrease flow.

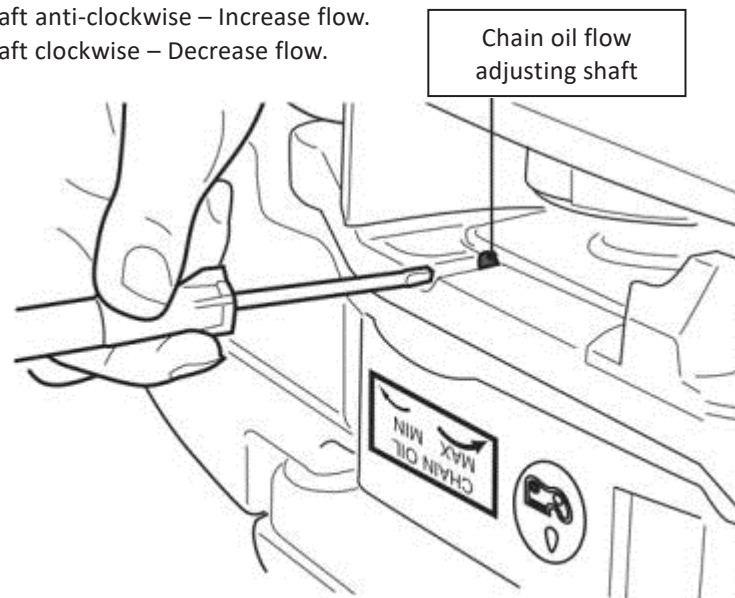

CHECKING CLUTCH FUNCTIONALITY

Before each use, check and confirm that the saw chain does not rotate when the machine is at idle speed.

IS THE CHAIN TENSION IN ORDER AND THE CHAIN SHARP?

Check a new chain's tension, every 10 minutes during initial operation. During the first uses, a new chain can lengthen considerably. The condition of the chain influences the cutting performance of the machine. Only a sharp chain protects the chainsaw from overload.

ARE YOU WEARING THE SUITABLE & NECESSARY PROTECTIVE EQUIPMENT?

Whenever the machine is in use, safety glasses/goggles must be worn to safeguard against flying objects. Hearing protection must also be used to protect the operators hearing. If the operator is working in an area where there is a risk of falling objects, a safety helmet must also be worn. Wear boots with saw protection, steel-toe cap and non-slip sole. Suitable chainsaw protection gloves are also recommended. Adequate protective clothing will reduce personal injury from flying debris or accidental contact with the saw chain.

CARBURETTOR ADJUSTMENT

The carburettor has been factory adjusted but may require fine tuning due to change in operating conditions. If the carburettor needs to be adjusted, be sure to adjust it with the bar and saw chain in position. Before adjusting the carburettor, make sure that the air & fuel filters are clean and fresh, correctly mixed fuel is being used.

H and L needles are restricted within the number of turns as shown:

H needle –1/4 L needle –1/4

Start engine and allow it to warm up in low speed for a few minutes.

Turn idle adjusting screw 'T' (1) anti-clockwise, so that the saw chain does not turn. If idle speed is too slow, turn the idle adjusting screw (1) clockwise.

Make a test cut, adjust the H needle for best cutting power, not for maximum speed.

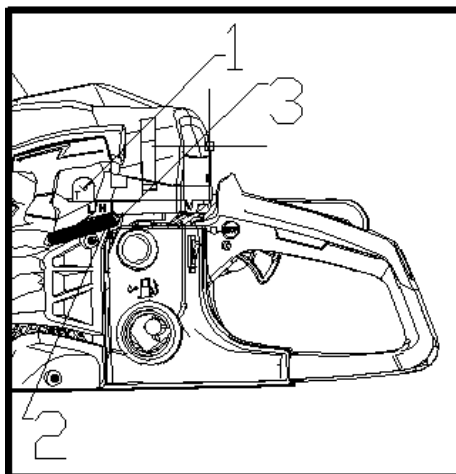

KICKBACK

Kickback is the sudden backward/upward motion of the chainsaw, occurring when the chain (at the tip of the chain bar) comes into contact with a log or wood, or when the chain becomes jammed. When Kickback occurs, the chainsaw reacts unpredictably and can cause severe injuries to the operator or bystanders. To avoid Kickback:

- Saw with the guide bar at a flat angle
- Never work with a loose, widely stretched or heavily worn out chain.
- Ensure the chain is sharpened correctly.
- Never saw above shoulder height.
- Never work with the tip of the guide bar.
- Always hold the chainsaw firmly with two hands.
- Always use a low kickback chain.
- Apply the metal spike for leverage.
- Ensure correct chain tension.

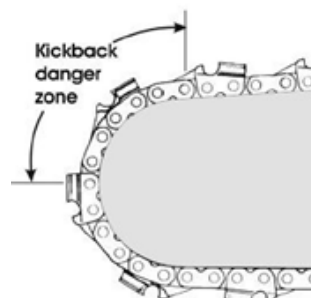

It is extremely important that the chain brake is checked for proper operation before each use and that the chain be sharp in order to maintain the kickback safety level of this saw. Removal of the safety devices, inadequate maintenance, or incorrect replacement of the bar or chain may increase the risk of serious personal injury due to kickback.

SAWING

It is recommended to first practice sawing easy logs. This also helps you get accustomed to your unit. Always follow all the safety regulations which can restrict the use of the machine.

- The chainsaw must only be used for cutting wood. It is forbidden to cut other types of material.



- Vibrations and kickback vary with different materials and the requirements of the safety regulations would not be respected.
- Do not use the chainsaw as a lever for lifting, moving or splitting objects.
- Do not lock it over fixed stands.
- It is forbidden to hitch tools or applications to the P.T.O. that are not specified by the manufacturer.
- It is not necessary to force the saw into the cut. Apply only light pressure while running the engine at



INSTRUCTION MANUAL

- full throttle.
- It is recommended that daily inspection before use and after dropping or other impacts to identify significant damage or defects.
- Racing the engine with the chain seized in a cutaway can damage the clutch system. When the saw chain is caught in the cut, do not attempt to pull it out by force, but use a wedge or a lever to open the cut.

GENERAL BEHAVIOUR

- Hold the chainsaw on the right-side of your body, during use.
- Always hold the chainsaw firmly with both hands. Hold the front handle with your left hand and the rear handle with trigger in your right hand.
- The chain must be running at full speed before it makes contact with the wood.
- Use the metal gripping spike on the front of the chainsaw, to secure onto the wood before starting to cut
- Reset the metal gripping spike at a low point when sawing thicker logs, by pulling the chainsaw, slightly backwards, until the gripping spike releases and reposition at a lower level to continue sawing. Do not remove the chainsaw completely from the wood.
- Do not force the chain whilst cutting, let the chain do the work, using the gripping spike to apply minimal leverage pressure.
- Do not operate the chainsaw with arms fully extended or attempt to saw areas which are difficult to reach, or on a ladder. Never use the chainsaw above shoulder height.
- Sawing is optimized when the chain speed remains steady during cutting. Beware when reaching the end of the cut. The weight of the saw may change unexpectedly, as it cuts free from the wood. Accidents can occur to the legs and feet. Always remove the saw from a wood cut while the saw is running

METAL GRIPPING SPIKE

The metal gripping spike must always be put on while using the chainsaw on tree trunk. Push the metal gripping spike into the tree trunk by using the rear handle. Push the front handle in the direction of cutting line. The gripping spike must remain set for further saw guiding if necessary.

Use the gripping spike when cutting trees and thick branches, it can ensure your safety and decrease the working strength and vibration level.

FOREIGN OBJECTS

If there's a foreign object between the cutting material and chainsaw, turn off the machine. Wait until it stops completely. Wear safety gloves and remove the foreign object. If the chain must be removed, a trial run must be conducted after the cleaning and new installation. If vibration or mechanical noise is discovered, please stop and contact your local approved service dealer.

LOGGING & LIMBING



WARNING

Always ensure your foothold as well as stability of the tree.

Be alert to the rolling over of a cut log.

Avoid kickback of the saw.

Before starting work, check the direction of bending force inside the log to be cut.

Always finish cutting from the opposite side of bending direction to prevent the guide bar from being caught in the cutaway.

CUTTING LOGS

Observe the following safety instructions:

Support the log being cut, to prevent face sides from closing in against each other, which would result in the chain being jammed or pinched.

Position and set short logs safely prior to sawing. Saw only wood or wooden objects.

When sawing, always take care to avoid hitting stones, nails etc, as these could be thrown up, cause damage to the chain or serious injury to the operator or bystanders.

Keep a running saw clear of wire fencing or the ground.

Use of the saw to thin out branches or bushes is not approved. Length cuts must be carried out with care, as

leverage with the gripping spike is not possible. Saw at a flat angle to avoid kickback. When working on a slope, operate above or to the side of the trunk or laying tree. Be careful not to trip over tree stumps, branches, roots, etc.

CUTTING WOOD UNDER TENSION

There is a high risk of accidents when sawing wood, branches or trees under tension. Be extremely careful. Leave saw jobs like these to professionals.

When sawing logs supported on both ends, start the cut from above (Y) about 1/3 of the diameter into the log and then finish the cut (Z) from below, in order to avoid contact of the chainsaw with the ground. When sawing logs supported on only one end, start the cut from below (Y) about 1/3 of the diameter into the log and finish the cut from above (Z) in order to avoid splitting or jamming of the chainsaw.

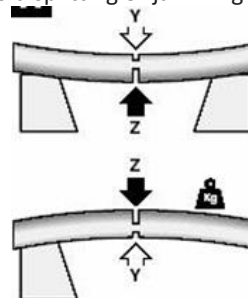

FELLING TREES

Always wear a hard hat to protect your head against falling branches.

The chainsaw can only be used to fell trees smaller in diameter than the length of the guide bar.

1. Secure work area. Ensure no persons or animals are in the vicinity of the falling tree. Never attempt to free a jammed saw with the motor running. Use wooden wedges to free the chain and guide bar. When cutting and felling operations are being performed by two or more persons, at the same time, the felling operations should be separated from the cutting operation by a distance of at least twice the height of the tree being felled. Trees should not be felled in a manner that would endanger any person, strike any utility line or cause any property damage. If the tree does make contact with any utility line, the relevant utility owner/company should be notified immediately. The chainsaw operator should keep on the uphill side of the terrain as the tree is likely to roll or slide downhill after it is felled.
2. An escape path should be planned and cleared as necessary before cuts are started. The escape path should extend back and diagonally to the rear of the expected line of fall.
3. Before felling is started, consider the natural lean of the tree, the location of larger branches and the wind direction to judge which way the tree will fall. Remove dirt, stones, loose bark, nails, staples and wire from the tree.

Notching undercut: Make the notch (X-W) 1/3 the diameter of the tree, perpendicular to the direction of falls as make the lower horizontal notching cut first. This will help to avoid pinching either the saw chain or the guide bar when the second notch is being made.

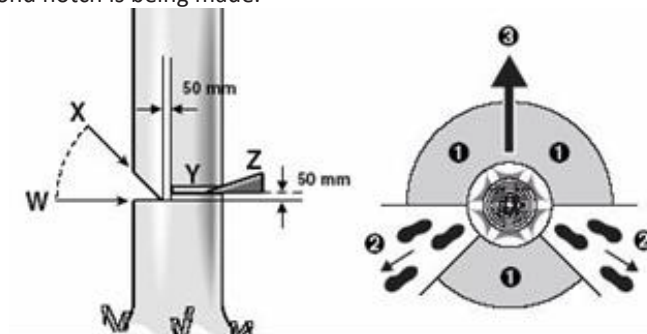

Felling back cut: Make the felling back cut (Y) at least 50 mm higher than the horizontal notching cut. Keep the felling back cut parallel to the horizontal notching cut. Make the felling back cut so enough wood is left to act as a hinge. The hinge wood keeps the tree from twisting and falling in the wrong direction. Do not cut through the hinge. As the felling gets close to the hinge the tree should begin to fall. If there is any chance that the tree may not fall in desired direction or it may rock back and bind the saw chain, stop cutting before the felling back cut is complete and use wedges of wood, plastic, or aluminum to open the cut and drop the tree along the

INSTRUCTION MANUAL

desired line of fall. When the tree begins to fall remove the chainsaw from the cutting, stop the motor, put the chainsaw down, and then use the retreat path planned. Be alert for overhead limbs falling and watch your footing. To complete the felling operation, drive a wedge (Z) into the horizontal cut. Beware of falling branches when the tree starts to move.

LIMBING A TREE

Limbing is removing the branches from a fallen tree. When limbing, use larger lower limbs to support the log off the ground. Remove the small limbs in one cut as illustrated. Branches under tension should be cut from the bottom up to avoid binding the chainsaw.

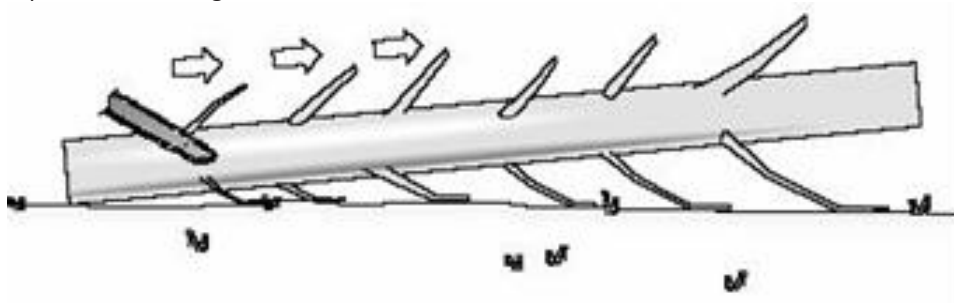

BUCKING A LOG

Bucking is cutting a log into lengths. It is important to make sure your footing is firm, and your weight is evenly distributed on both feet. When possible, the log should be raised and supported by the use of limbs, logs or chocks. Follow the simple directions for easy cutting.

When the log is supported along its entire length as illustrated, it is cut from the top (overbuck).

When the log is supported on one end, as illustrated below, cut $\frac{1}{3}$ the diameter from the underside (underbuck). Then make the finished cut by over bucking to meet the first cut.

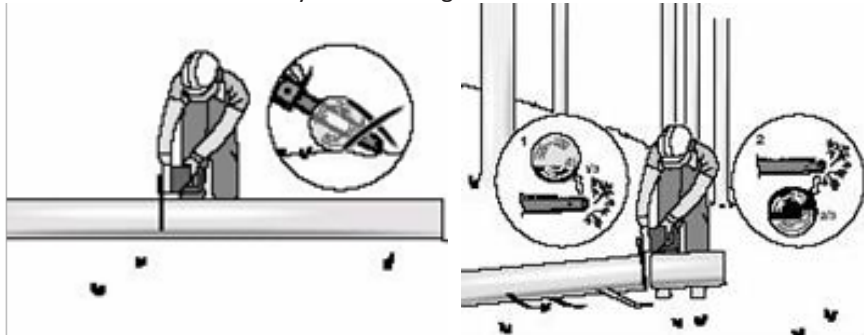

When the log is supported on both ends, as illustrated, cut $\frac{1}{3}$ the diameter from the top overbuck. Then make the finished cut by under bucking the lower $\frac{2}{3}$ to meet the first cut.

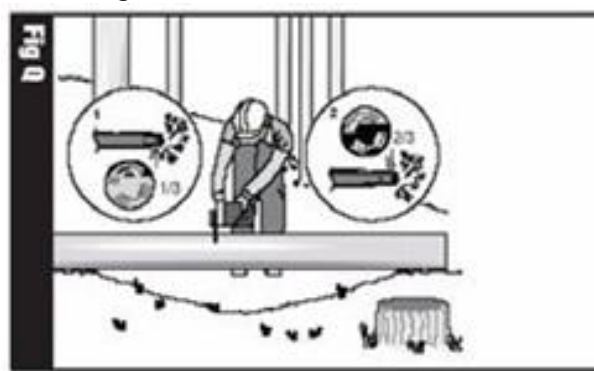

When bucking on a slope always stand on the uphill side of the log, as illustrated. When "cutting through", to maintain complete control, release the cutting pressure near the end of the cut without relaxing your grip on the chainsaw handles. Don't let the chain contact the ground. After completing the cut, wait for the saw chain to stop, before you move the chainsaw. Always stop the motor before moving from tree to tree.

PERSONAL CARE

1. Walk, never run with the chainsaw, be very careful when operating on uneven or rough ground.
2. Be careful when changing the direction on a slope.
3. Do not cut on excessively steep slopes.
4. Do not remove cutting debris from the machine or on the blade by bare hand. Instead wear safety gloves and use suitable tools such as a brush.
5. Check that all nuts, bolts and screws are well tightened.
6. Before mowing make sure that the saw chain and bar are secure. When saw chain cutting edges require re-sharpening, this must be done evenly on both sides, to prevent any imbalance. If you are unsure how to sharpen the saw chain, please visit your local Approved Service Dealer. If the saw chain or bar are damaged, they must be replaced.
7. When cutting, always wear the appropriate PPE (Personal Protective Equipment).
8. Do not run the engine in an enclosed and/or poorly ventilated area, where gas from the engine contains carbon monoxide, which are dangerous for your health.
9. Work only when there is enough light.
10. Turn off the engine if you must leave the chainsaw unattended.
11. Never lift the chainsaw above shoulder height.
12. Stop the engine and remove the spark plug cover in these cases:
 - Transporting from one work area to another
 - Before any maintenance, repairing or checking operations.
 - Before carrying, lifting or removing the mower.
 - If you leave the chainsaw unattended.
 - After hitting a foreign object, stop the engine and check thoroughly the chainsaw in order to see if it is damaged. Take the machine to a local Approved Service Dealer for inspection if necessary. Repairs of this nature are not covered under the Manufacturer's warranty.
 - If the chainsaw vibrates in an abnormal way, find the reasons why, and take your machine to a local Approved Service Dealer.



CAUTION

**Allowing anyone to operate this machine without proper instruction may result in injury.
Wear sturdy, full coverage footwear. Operating this machine with bare feet, or with open toe shoes or sandals increases your risk of injury.**

Do not use the machine at night or in poor light.

Be sure to transport the machine from one place to another with the engine off.

Be sure to wear heavy gloves when cleaning underside of the deck or handling the blade.

To prevent damage, check the machine for any signs of damage or other faults when operated.



INSTRUCTION MANUAL

MAINTENANCE, CLEANING & STORAGE



WARNING

Improper maintenance & storage of the machine may void your warranty. Keep the machine clean for better and safer performance. Ensure the machine is stored in a dry room, away from any direct sunlight. Turn off the engine before performing any maintenance. If the engine must be run, make sure the area is well ventilated. The exhaust emits dangerous carbon monoxide gases.

MACHINE MAINTENANCE

Use only original equipment replacement parts. Other parts may not perform as well, may damage the unit and may result in injury. In addition, use of other parts may invalidate your warranty.

- Before each use, check all nuts & bolts to be sure they are sufficiently tightened.
- We recommend only manufacturer original parts are used when maintaining this machine. Failure to do so could invalidate your manufacturer's warranty.
- The engine must be switched off, with the spark plug cap removed, before the machine is unassembled, cleaned, serviced or maintained.

AIR FILTER

Dust on the air filter surface can be removed by tapping a corner of the filter against a hard surface. To clean dirt in the meshes, split the filter into halves and brush in gasoline. When using compressed air, blow from the inside.

To assemble the filter halves, press the rim until it clicks.

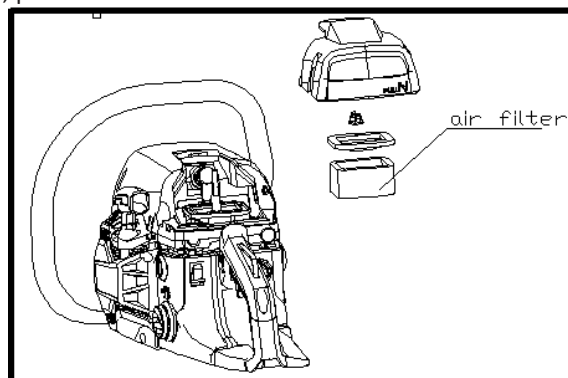

OILING PORT

Dismount the guide bar and check the oiling port (1) for clogging.

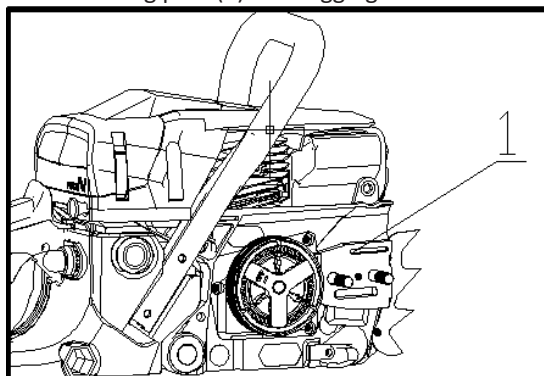

GUIDE BAR

When the guide bar is removed, clear sawdust in the bar groove and the oiling port (1). Grease the nose sprocket (3) from the grease port (2) on the tip of the bar using a grease gun.

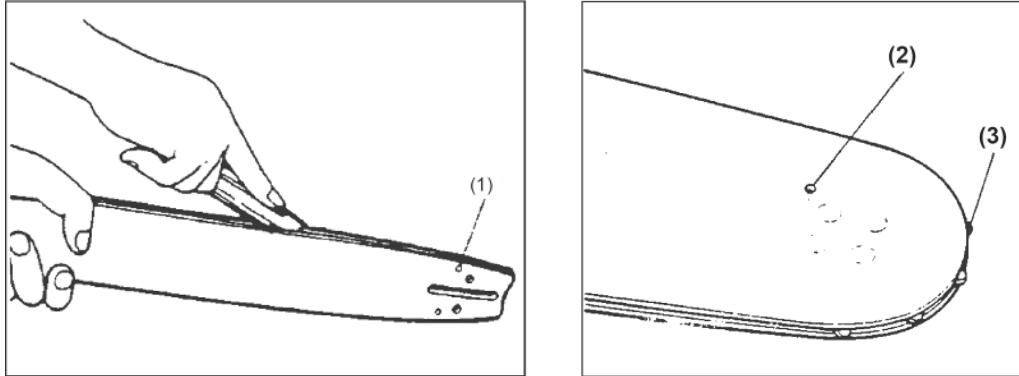

OTHERS

Check for fuel leakage and loose fastenings and damage to major parts, especially handle joints and guide bar mounting. If any defects are found, make sure to have them repaired before operating again.

SERVICE POINTS

CYLINDER FINS

Dust clogging between the cylinder fins will cause overheating of the engine. Periodically check and clean the cylinder fins after removing the air cleaner and the cylinder cover. When installing the cylinder cover, make sure that switch wires and grommets are positioned correctly in place.

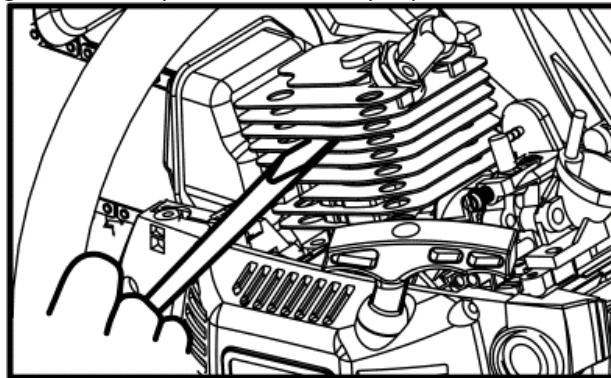

FUEL FILTER

Using a wire hook, take out the filter from the filler port. Disassemble the filter and wash with petrol or replace with a new one if needed. **IMPORTANT** - After removing the filter, use a pinch to hold the end of the suction pipe. When assembling the filter, take care not to allow filter fibres or dust inside the suction pipe.

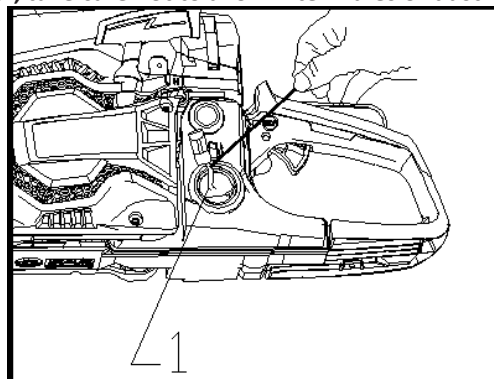

INSTRUCTION MANUAL

SPARK PLUG

Clean the electrodes with a wire brush and reset the gap to 0.6mm - 0.7 mm as necessary.
Spark plug type : see Specification section of instruction manual.

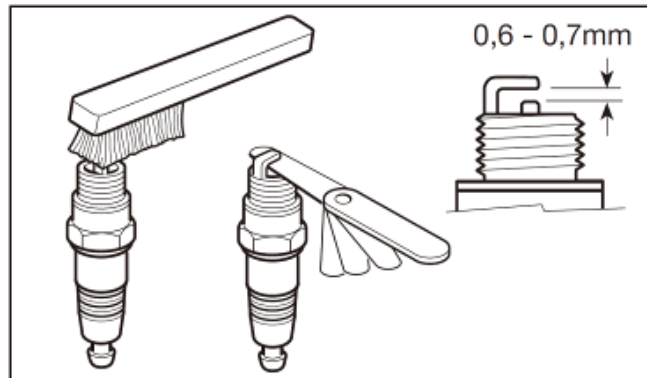

SPROCKET

Check for cracks and for excessive wear interfering with the chain drive. If the wear is considerable, replace it with new one. Never fit a new chain on a worn sprocket, or a worn chain on a new sprocket.

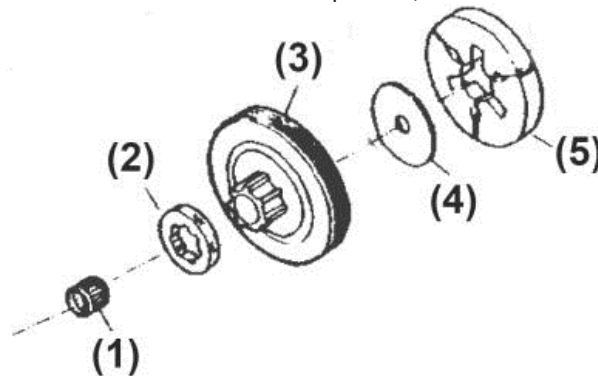

SAW CHAIN

It is very important for smooth and safe operation to keep the saw chain sharp at all times.

Your saw chain will need to be sharpened if:

- Sawdust becomes powder-like.
- You need extra force to cut.
- The cut way does not go straight.
- Vibration increases.
- Fuel consumption increases.

SAW CHAIN MAINTENANCE









WARNING

Be sure to wear safety gloves when undertaking any action involving the saw chain.

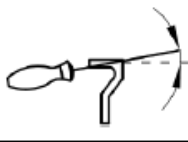
Filing:

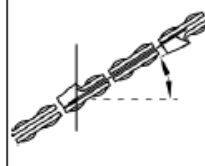
- Make sure the saw chain is held securely.
- Make sure the engine has stopped and is turned off, with the spark plug cap removed from the spark plug.
- Use a round file of correct size for your saw chain. File size 5/32"
- Place your file on the cutter and push straight forward.
- Keep the file position as illustrated.
- After every cutter has been set, check the depth gauge and file it to the proper level as illustrated.
- Be sure to round off the front edge to reduce the chance of kickback or tie-strap breakage.
- Make sure every cutter has the same length and edge angles as illustrated.

Type of chain	File diameter	Top plate angle	Down angle	Head tilt angle (55°)	Depth gauge standard
					
		Vise rotate angle 	Vise tilt angle 	Side angle 	
21BPX	5/32"	30°	0°	80°	0.025"
32S	5/32"	30°	0°	80°	0.025"

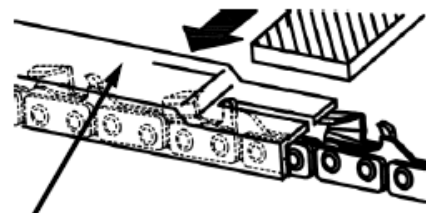

Depth gauge



File

GUIDE BAR MAINTENANCE

Guide bar

- Reverse the bar occasionally to prevent partial wear.
- The bar rail should always be square. Check for wear of the bar rail. Apply a ruler to the bar and the outside of a cutter. If a gap is observed between them, the rail is normal. Otherwise, the bar rail is worn. Such a bar needs to be corrected or replaced.

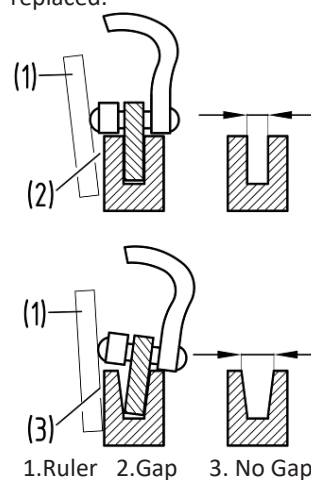

The table contains the details of the saw chain and guide bar required for your machine.

Pitch	Guide Bar				Chain	
	Length	Groove Width	Code	Number of Nose Teeth	Code	Number of Drive Links
0.325"	16" / 40cm	0.058" / 1.5mm	168PXBK095	7	21BPX066X	66

For replacement, use only approved bars and chains. Use of a non-approved combination, may cause serious personal injury, damage to the machine and also invalidate your warranty.



INSTRUCTION MANUAL

CLEANING



CAUTION

Do not use a water hose or pressure washer to clean the machine. Water can damage the engine or contaminate the fuel system.

STORAGE & TRANSPORT

The following steps should be taken to prepare your machine for storage.

STORING THE CHAINSAW FOR SHORT PERIODS

The chainsaw can be stored for short periods of time (less than 15 days) without performing any storage maintenance. Before placing the chainsaw into storage always carry out the following:

1. Allow the engine to fully cool.
2. Ensure the chainsaw is clean and clear of debris.
3. Store the chainsaw on a flat and level surface upright.
4. Store in a safe place which is not accessible by children or people who are not familiar with operation.

STORING THE CHAINSAW FOR EXTENDED PERIODS

If the chainsaw is to be placed into storage for more than 15 days, storage maintenance must be performed on the chainsaw. If the following steps are not carried out, when you next operate the chainsaw it may not start correctly and may need to be serviced.



CAUTION

Do not empty the petrol tank in enclosed areas, near fire or when smoking. Petrol fumes can cause explosions and fire

1. Empty the petrol tank with a petrol suction pump if available.
2. Alternatively, start the engine and let it run until any remaining petrol has been used up.
3. Empty the oil tank.
4. Remove the spark plug boot from the spark plug.
5. Clean the cooling fins of the engine cylinder and the housing
6. Be sure to clean the entire machine.
7. Store the machine in a well-ventilated place.
8. Store in a dry, clean and frost-protected place, out of reach of unauthorised persons and direct sunlight.



CAUTION

**The engine must have completely cooled down before storing.
DO NOT STORE fuel for longer than 30 days. Fuel can become stale and cause damage to the engine carburetor, which is not covered by the machine's manufacturer's warranty.**

TRANSPORT

- Empty the petrol tank
- Always let the engine run until it has used up the remainder of petrol in the tank.
- Empty the engine oil from the warm engine.
- Remove the spark plug boot from the spark plug.
- Clean the cooling fins of the cylinder and the housing.
- Use the original packaging to ship whenever possible.

TROUBLE SHOOTING

PROBLEM	POSSIBLE CAUSE	SOLUTION
Engine fails to start.	<ol style="list-style-type: none"> 1. On/Off Switch not activated 2. Spark plug cap not connected to spark plug. 3. Fuel tank empty 4. Fuel is over 30 days old and stale. 5. Block fuel pipe 6. Faulty or flooded spark plug 7. Engine flooded 	<ol style="list-style-type: none"> 1. Turn machine on. 2. Connect spark plug cap to spark plug. 3. Fill with clean, fresh fuel 4. Carburettor gummed up, take to approved service dealer for non-warranty repair. 5. Clean fuel pipe & filter 6. Clean, adjust or replace spark plug. 7. Remove spark plug, dry off and reseal.
Engine runs erratic	<ol style="list-style-type: none"> 1. Choke still on with warm engine 2. Spark plug cap loose. 3. Blocked fuel line 4. Stale fuel 5. Water or dirt in fuel system 6. Dirty air filter 7. Carburettor operating incorrectly. 8. High/Low needles incorrectly adjusted. 	<ol style="list-style-type: none"> 1. Deactivate choke. 2. Connect cap to spark plug and ensure tight. 3. Clean fuel pipe and filter 4. Remove fuel and use fresh fuel. 5. Drain fuel tank, refill with fresh fuel 6. Clean air filter 7. Have carburettor inspected by approved service dealer and adjusted. 8. Adjust High/Low needles as advised in this manual.
Engine overheats	<ol style="list-style-type: none"> 1. Incorrect 40:1 fuel to two-stroke oil mixture 2. Air flow restricted 3. Carburettor operating incorrectly. 	<ol style="list-style-type: none"> 1. Mix correct fuel:oil mixture. Fill fuel tank. 2. Remove blower housing and clean. 3. Have carburettor inspected by approved service dealer and adjusted.
Engine hesitation at high speed	<ol style="list-style-type: none"> 1. Spark plug gap incorrect. 	<ol style="list-style-type: none"> 1. Adjust spark plug gap to between 0.6-0.8mm
Engine idles erratically	<ol style="list-style-type: none"> 1. Spark plug fouled, faulty or gap incorrect. 2. Carburettor not functioning correctly. 3. Dirty air filter. 	<ol style="list-style-type: none"> 1. Adjust spark plug gap to between 0.6-0.7mm 2. Have carburettor inspected by approved service dealer and adjusted. 3. Clean air filter.
Uneven cut	<ol style="list-style-type: none"> 1. Blunt saw chain 	<ol style="list-style-type: none"> 1. Have saw chain sharpened or replaced.
Chain oil does not lubricate chain	<ol style="list-style-type: none"> 1. Check oil for substandard quality 2. Check oil passage and ports, maybe blocked 	<ol style="list-style-type: none"> 1. Replace chain oil with correct quality. 2. Clean all relevant exits.

If you are unable to resolve any issue on your machine, please contact your local approved service dealer, who can be found at www.webbgardenpower.co.uk or contact customerservice@webbgardenpower.co.uk.



REPLACEMENT PARTS

Please find on the following pages, parts lists and drawings for your machine. Should you require a replacement part, please call our Spares Team on 01793 333212, option 1 for assistance.

Webb recommends the use of Handy Parts oils, fuel additives, nylon lines pre-packed parts for all our machines.





INSTRUCTION MANUAL

PARTS DIAGRAM

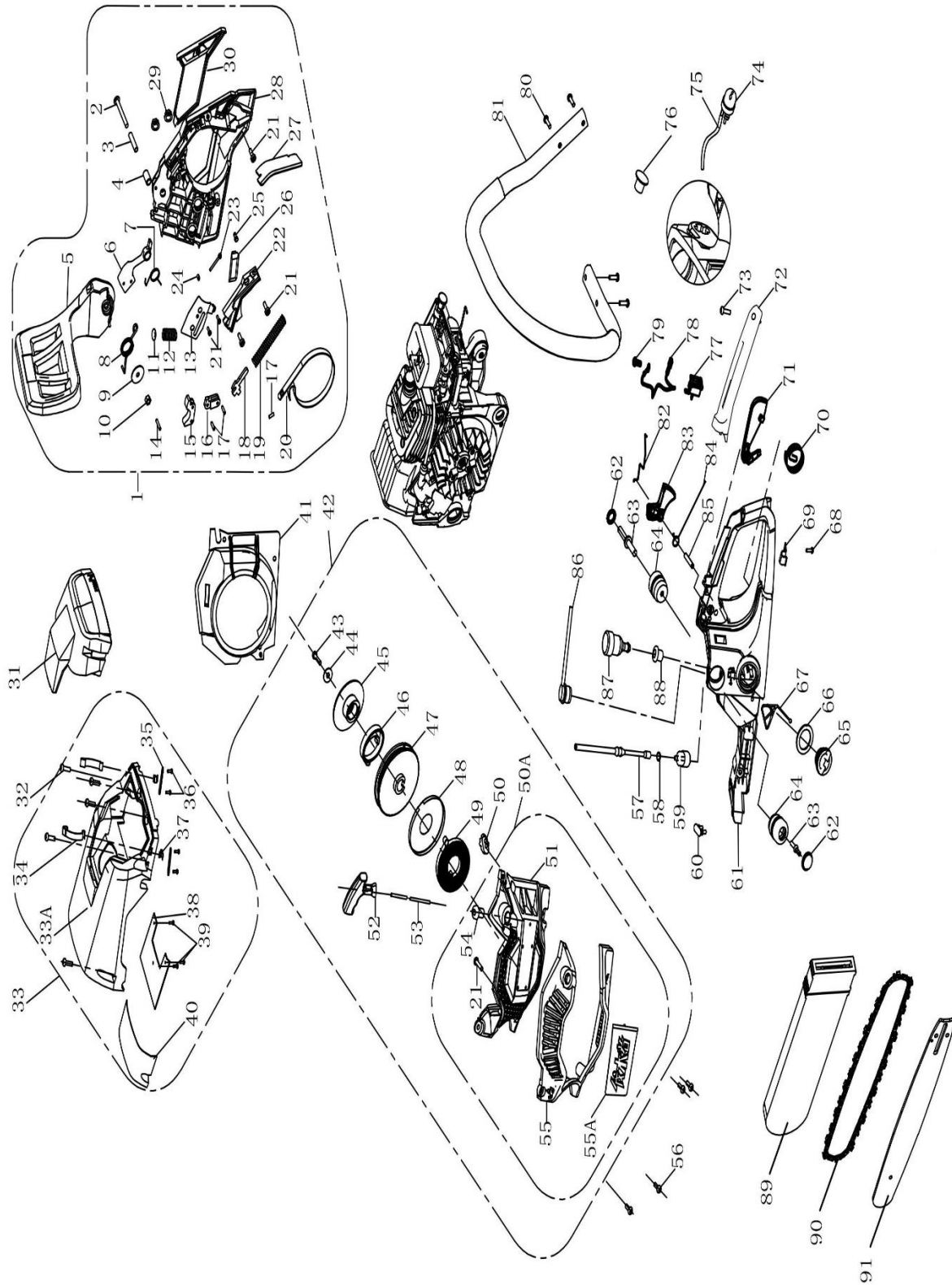

PARTS LIST

Item No	Webb Part No.	Webb Description	Qty	Item No	Webb Part No.	Webb Description	Qty	Item No	Webb Part No.	Webb Description	Qty
1	WE204-A4522120000	Clutch cover assembly	1	31	WE204-A4522130001	Air Filter Cover	1	60	WE204-A450110001	Shock Rubber	1
2		Screw M5x40	1	32	WE204-29E	Screw M5x16	5	61	WE204-A452210100	Base	1
3		Pin Gland 5x6.3x30	1	33	WE204-A4522130100	Upper Cover Assembly	1	62	WE204-A4501000007	Dust Cover	2
4		Heavy Brake Gland 6.3x9x15	1	33A		Upper Cover Casing	1	63	WE204-A4501000008	Rear Handle Fixing Screw	2
5		Font Damper	1	34		Clip	2	64	WE204-A450110100	Shock Rubber Gland	1
6		Heavy Brake	1	35		Cards & Pressure Plates	2	65	WE204-A380310301	Oil Filler Cap	2
7		Heavy Brake Spring	1	36		Screw ST2.9x6.5	4	66	WE204-A3803110303	Oil Filler Rubber Washer 23x34x1.7	1
8		Brake Torsion Rod Spring	1	37		Clip Fixing Plate	2	67	WE204-A3803110302	Anti-Drop Plate	1
9		Washer 5.2x20x1.2	1	38		Top Cover Air Guide Sheet	1	68	WE204-68	Screw ST4x5	1
10		Locknut M5	1	39		Screw ST3.5x6	3	69	WE204-A4522110002	Fixed Leaf	1
11		Spring Base	1	40		Septum for Cylinder Shield	1	70	WE204-A4111000013	Sleeve Spring	1
12		Front Guard Spring	1	41	WE204-A4522000001	Flow Guide Cover	1	71	WE204-A4501110006	Safety Trigger	1
13		Tensioner Cover Plate	1	42	WE204-A4522100000	Recoil Assembly	1	72	WE204-A452210001	Rear Handle Cover	1
14		Pin 3x14	1	43		Screw ST4.8x14	1	73	WE204-73	Screw ST4.8x14	1
15		Main Level	1	44		Plate Washer 5	1	74	WE204-A3803110100	Primer Bulb	1
16		Secondary Pull-Rod	1	45		Coil Spring Cover 1	1	75	WE204-A4501110010	Pump Pipe (2.5x5x155)	1
17		Pin 3x9	3	46		Coil Spring	1	77	WE204-A4501060700	On/Off Switch	1
18		Brake Control Rod	1	47		Start Plate	1	78	WE204-A3803060400	Ground Lead	1
19		Brake Spring	1	48		Coil Spring Cover 2	1	79	WE204-79	Screw M5x10	1
20		Brake Strap	1	49		Start Coil Spring	1	80	WE204-80	Screw ST5x16	4
21		Tapping Screw ST4.2X9.5	6	50		LH Sheathing	1	81	WE204-A4522000100	Front Handle	1
22		Brake Spring Cover Plate	1	50A		Start Housing Assembly	1	82	WE204-A4522010001	Throttle Rod	1
23		Tightener Screw	1	51		Start Housing	1	83	WE204-A4501110004	Throttle Trigger	1
24		Tension Block	1	52		Pull Handle	1	84	WE204-A4501110005	Throttle Trigger Spring	1
25		Tension Gear	1	53		Recoil Rope	1	85	WE204-85	Pin 6x24	1
26		Chain Guide Block	1	54		Eyelet	1	86	WE204-A4501110011	Oil Nozzle	1
27		Dust Shield	1	55		Actuator Cover Liner	1	87	WE204-A4501110200	Balancer	1
28		Clutch Cover	1	56	WE204-56	Screw M5x18	4	88	WE204-A3803110006	Balancer Seat	1
29		Nut M8	2	57	WE204-A4501110002	Fuel Pipe	1	89	WE204-A4501150001	Blade Cover	1
30		Right Cover Label	1	58	WE204-A4501110008	Circclip	1	90	WE208-A4501150400	Saw Chain	1
				59	WE204-A4501110300	Fuel Filter	1	91	WE208-A4501150100	Guide Bar	1



INSTRUCTION MANUAL

PARTS DIAGRAM

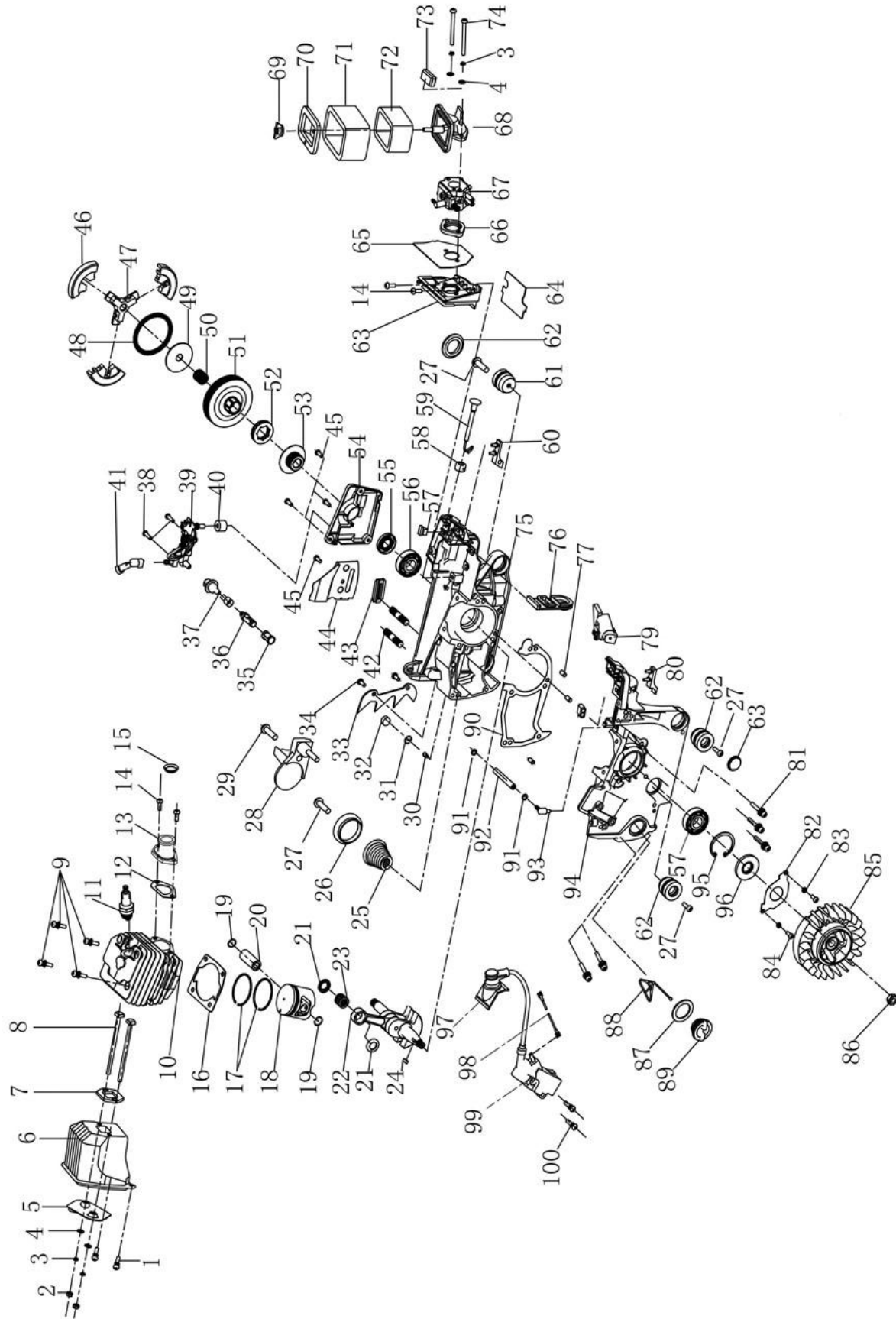

PARTS LIST

Item No	Webb Part No.	Webb Description	Qty	Item No	Webb Part No.	Webb Description	Qty	Item No	Webb Part No.	Webb Description	Qty
1	WE204-1E	Screw M5x14	2	34	WE204-34E	Screw M5x10	2	67	WE204-A4501010200	Carburettor	1
2	M-M5PLAINNUT	Nut M5	2	35	WE204-A4501140302	Oil Filter Screen	1	68	WE204-A5616040100	Air Filter Housing 1	1
3	M-M5FLATWASHER	Washer 5-1	4	36	WE204-A4501140301	Oil Filter	1	69	WE204-A3809010001	Air Filter Locknut	1
4	WE204-4E	Washer 5-2	4	37	WE204-A4501140001	Oil Tube	1	70	WE204-A5616040001	Air Filter Cover	1
5	WE204-A4501050001	Silencer Cover Plate	1	38	WE204-38E	Screw M4x14	2	71	WE204-A5616040002	Air Filter Foam	1
6	WE204-A4501050000	Silencer Body	1	39	WE204-A4501140100	Oil Pump	1	72	WE204-A5616040200	Air Filter Housing 2	1
7	WE204-A4501010006	Silencer Sealing Plate	1	40	WE204-A4501010027	Sponge Transition Coil	1	73	WE204-A4501010010	Cushion of Air Intake Socket	1
8	WE204-A4501010028	Muffler Connecting Screw	2	41	WE204-A4501140002	Nozzle	1	74	M-M5x50	Screw M5x50	2
9	M-M5X20	Screw M5x20	4	42	WE204-42E	Double-Screw Bolt AM8-M8X26-8.8	2	75	WE204-A4501020201	Right Case Body	1
10	WE208-A4501010003	Cylinder Body	1	43	WE204-A4501010019	Chain Guide Block	1	76	WE204-A4501010012	Dust Plate	1
11		Spark Plug	1	44	WE204-A4501010021	Damper	1	77	WE204-77E	Pin 5x10	3
12	WE204-A4501010004	Air Intake Tube Sealing Plate	1	45	WE204-45E	Screw M4x10	4	79	WE204-A4504000002	Idle Adjusting Guide Set	1
13	WE204-A4501010400	Air Intake Tube	1	46	WE204-A4501010302	Shoe Block	3	80	WE204-A4501010015	Left Shock Block	1
14	WE204-14E	Screw M5x12	4	47	WE204-A4501010301	Retainer	1	81	M-M5X25	Screw M5x25	5
15	WE204-A4501010020	Hold Coil	1	48	WE204-A4501010303	Clutch Extension Spring	1	82	WE204-A4501010023	Oil Seal Damper	1
16	WE204-A4501010005	Cylinder Sealing Plate	1	49	WE204-A4501010022	Clutch Adjusting Washer	1	83	WE204-83E	Washer 4	2
17	WE204-A5001030001	Piston Ring	2	50	WE204-A4501011300	Needle Bearing 12x15x14.5	1	84	WE204-84E	Screw M4x8	2
18	WE208-A4501030300	Piston	1	51	WE204-A4501010033	Clutch Shell	1	85	WE204-A5616060200	Flywheel	1
19	WE204-A4501030003	Piston Pin Circlip	2	52	WE204-A6201010012	Sprocket	1	86	WE204-86	Nut M8x1	1
20	WE208-A4501030002	Piston Pin	1	53	WE204-A4501010900	Turbine	1	87	WE204-A4501010802	Packing Washer 20x30x2	1
21	WE204-A4501030004	Needle Bearing Ring	2	54	WE204-A4501010018	Cover Plate	1	88	WE204-A3803110302	Anti-Drop Plate	1
22	WE204-A4501030100	Crankshaft Connecting Bar Components	1	55	WE204-A4501011200	Oil Seal 15x28x4.5	1	89	WE204-A4501010801	Oil Cover	1
23	WE204-A4501030200	Needle Bearing 11x15x12.5	1	56	WE204-56E	Bearing 6202 Grade D 15x35x11	2	90	WE204-A4501020001	Body Sealing Plate	1
24	WE204-A4501010036	Semi-Circular Key 3x3.7x10	1	57	WE204-A4501010014	Shock Block 1	1	91	WE204-A4501020103	Circlip	2
25	WE204-A4501000004	Conical Spreader Spring	1	58	WE204-A4501010013	Throttle Lever Retaining Bracket	1	92	WE204-01020102	Suction Tube 2.5x7x105	1
26	WE204-A4501000003	Conical Spreader Base	1	59	WE204-A4501010700	Throttle Rod	1	93	WE204-A4501020300	Suction Jet	1
27	WE204-27E	Tapping Screw ST5x16	4	60	WE204-A4501010016	Right Shock Block	1	94	WE204-A4501020101	Left Case Body	1
28	WE204-A45010000100	Chain Catcher	1	61	WE204-A4501011000	Cushion Socket	3	95	WE204-95E	Ring 35	1
29	WE204-29E	Screw M5x16	1	62	WE204-A4501000002	Dust Cover	3	96	WE204-A4501011100	Oil Seal 15x35x4.5	1
30	WE204-A4501020202	Aeration Jet	1	63	WE204-A4501010500	Air Filter Support	1	97	WE204-A4507060101	Spark Plug Cap	1
31	WE204-A4501020203	Aeration Jet Circlip	1	64	WE204-A4501010009	Backing Board	1	98	WE204-A4501060600	Extension Conductor	1
32	WE204-A4501010026	Sponge Transition Block	1	65	WE204-A4501010008	Sealing Plate	1	99	WE204-A4516060300	Ignition Coil	1
33	WE204-A4501010024	Bumper Spikes	1	66	WE204-A4501010017	Air Filter Flange	1	100	M-M5X20	Screw M5x20	2



EC DECLARATION OF CONFORMITY

We Handy Distribution Ltd - SN3 5HY (Importer) declare that the product:

Designation: Petrol 16"/40cm Chainsaw
Model(s): WEPCS16
Product No.: 1938316001
Type/Serial No. As per rating label on machine
Cutting Length: 16"/40cm
Engine Displacement: 45.02cm³
Maximum Engine Power: 1.7kW
Maximum Engine Speed: 12000 min⁻¹
Maximum Chain Speed: 23.114 m/s

Complies with the following directives:

Machinery Directive 2006/42/EC

The conformity assessment procedure followed was in accordance with:
EN ISO 5395-1:2013/A1:2018; EN ISO 5395-2:2013/A2:2017

EMC Directive 2014/30/EU

EN ISO 14982: 2009

Outdoor Noise Directive 2000/14/EC & 2005/88/EC

Guaranteed Sound Power Level L_{WA}: 114 dB(A)

Emission Sound Pressure Level L_{PA}: 97.5 dB(A) - uncertainty: K_{PA} 3.0 dB(A) According to 2000/14/EC

Vibration a_{hv}: Front Handle 7.65 m/s² Rear Handle 8.49 m/s² - uncertainty K: 1.5 m/s²

Notified Body:

Intertek Deutschland GmbH,

Addresses:

Stangenstraße 1, 70771 Leifelden - Echterdingen

Authorised signatory and technical file holder

Date: 22/10/2021

Signature:

A handwritten signature in black ink, appearing to read "S Belcher", written over a horizontal line.

Name: Mr Simon Belcher

Position: Chairman

Company: Handy Distribution Ltd

Address: Murdock Rd, Swindon, Wiltshire, SN3 5HY.





INSTRUCTION MANUAL

This Service Book is provided with your Webb, to help you look after your purchase to our recommendations and enable you to take advantage of the conditional manufacturer domestic warranty*.

Present this service book to your authorised Webb repair dealer, whenever a service or a warranty appraisal is required.

The booklet is applicable to the following products, in the UK only:

- Ride On Lawn Tractors
- Cylinder Lawnmowers
- Petrol Rotary Lawnmowers
- Petrol Hand Held Range

Please register your machine using the following pages or at www.webbgardenpower.co.uk. By registering your machine, you agree to maintain the machine in accordance with the service schedules specified in this manual and services duly recorded. (Not applicable for Webb electric handheld machines). You may be asked to produce this booklet as proof of servicing in the event of a claim. Proof of purchase should also be kept as a reference.

Ensure you have the following information available from your machine product label. The two examples below can be found on your machine:



1. Model Number

2. Serial & Product Number

Please complete using BLOCK CAPITALS.
Sections marked* must be completed to validate Warranty.

SERVICE BOOK

1. Users Statement of Warranty

Each new machine is warranted against defective material or assembly of material under normal usage. The warranty applies to the original purchaser, is not transferable and covers faulty parts and the labour involved in replacing and repairing those parts, which are of original manufacture.

2. Period of Warranty - valid from 1 January 2020

Webb (excludes Dynamic, Legacy & Heritage), 2 year conditional warranty from the original date of sale to the first domestic user.

Webb (Dynamic, Legacy & Heritage) 1 year warranty from the original date of sale to the first domestic user.

90 days from the original date of sale to the professional/commercial or for hire user.

Engine warranty as per the engine manufacturer's warranty, which will be supplied with the machine.

90 days from the original date of sale for Replacement Spare Parts

All machines' must be serviced within the first 14 months from the original date of purchase, to qualify for a second year parts & labour warranty, details of the service must be recorded in the service record within this manual.

A reduced warranty period of 90 days applies to those items which are subject to normal wear and tear and in normal use, will need replacement or adjustment.

These items are chargeable after 90 days of ownership.

Filters
Tyres / Wheels
Drive chains and belts
Brake & clutch friction components
Control cable & starter cords
Fluids & lubricants
Spark plugs
Blades (Lawnmowers & Brushcutters)
Cutter bars (Hedgecutters)
Drive & clutch cable surfaces
Nylon Lines (Line Trimmers)
Carburettor cleaning
Bearings
Bushes
Electric cable
Grass collectors

3. Not covered by this warranty

(a) The warranty policy does not cover any depreciation or damages caused by ordinary wear, rusting or corrosion, lack of correct maintenance or operation, misuse, abuse, lack of transportation or accident.

(b) The warranty policy does not cover any costs necessary for the standard periodic maintenance services instructed by the operators manual, or service parts replacement which would include oil, filters, tyres, belts, brake linings, fuses, blades, seals and other service parts unless it can be proven that the item has evidence of faulty manufacture.

(c) The warranty policy will not cover failure or damage caused as a result of parts or accessories being modified without the written approval of GJ Handy & Co Ltd.

(d) The warranty policy will not cover the unit if non-genuine parts have been fitted and as a result damage has occurred to the unit.

(e) The warranty policy is non-transferable and is only applicable to the original purchaser.

4. Disclaimer

(a) This warranty is only a remedy for defect of products. GJ Handy & Co Ltd will never warranty in terms of the merchantability or the fitness for a particular purpose.

(b) No person is authorised to make any warranties, representations or promises, expressed or implied, on behalf of GJ Handy & Co Ltd, or to modify the terms conditions or limitation of this warranty policy in any way.



INSTRUCTION MANUAL

(c) Neither GJ Handy & Co Ltd nor any company affiliated with GJ Handy & Co Ltd shall be liable in any event or manner whatsoever for incidental or consequential damages or injuries, including, but not limited to, loss of crops, loss of profit, out of pocket expenses or profits, rental of substitute equipment or other commercial losses.

5. General

(a) Most warrantable failures show up within the first few weeks of use. These failures are usually straightforward and warranty assessment is relatively easy.

(b) Failures relating to cutter decks and belts need careful investigation, as the cause may not always be straightforward. Look for damage to blades and pulleys especially when the cutter belt or blade boss have snapped or cracked as this could be due to impact damage.

(c) Customers should always refer to the operator/instruction manual when any disputed problem arises, you will find most areas covered within the manual.

Protecting your machine

Maintenance

Regular maintenance of your Webb machine is essential to ensure it operates, safely, efficiently and therefore reducing the environmental impact.

It is the owner's responsibility to ensure that their Webb machine is maintained at specific intervals. Any approved Webb service dealer can undertake a service, which are specialised in our products and will be aware of your particular machine and any technical updates which will save valuable time & money.

If you are using your machine in dry, dusty or high temperatures, you will need to service the machine more regularly.

Fuel (if applicable)

Due to ongoing efforts by fuel companies to reduce emissions, unleaded petrol will oxidize & deteriorate in storage overtime, leaving residue from detergent components.

Fuel deterioration problems may occur when petrol is stored for over 30 days. If you are planning to store fuel for over 30 days, we recommend you add Handy Parts Sure-Start fuel stabilizer to fresh fuel after purchasing. Sure-Start cannot reconstitute stale fuel.

Storage

When storing your machine for an extended period, we do recommend that you follow the instructions of engine instruction manual.

Always store the fuel in a clean, approved and sealed container. If the container is steel, ensure it is not corroded. If the container is not filled to its recommended capacity, air can accelerate fuel deterioration.

Always store fuel away from direct sunlight, in a dark, cool environment.

SERVICE BOOK

Your servicing Webb approved dealer will stamp & date the below relevant sections, when the correct service actions have been completed.
PLEASE ENSURE THE SERVICE BOOK IS AVAILABLE FOR THE DEALER, DURING SERVICE WORK.

1st Service

This must be stamped by an approved service dealer to qualify for a free second year warranty.
(Excluding the Webb Electric Handheld machines)

12 Months

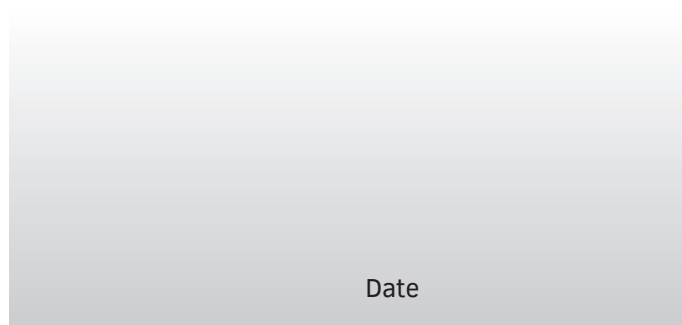

Date

24 Months

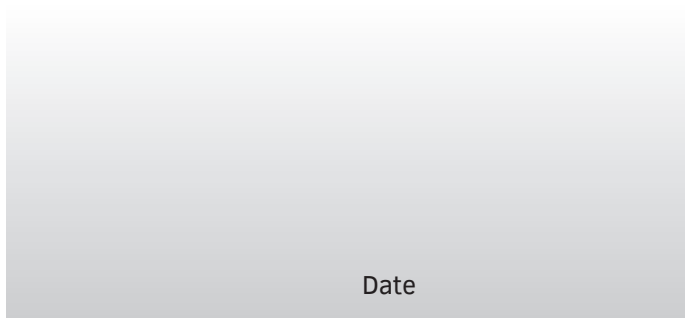

Date

36 Months

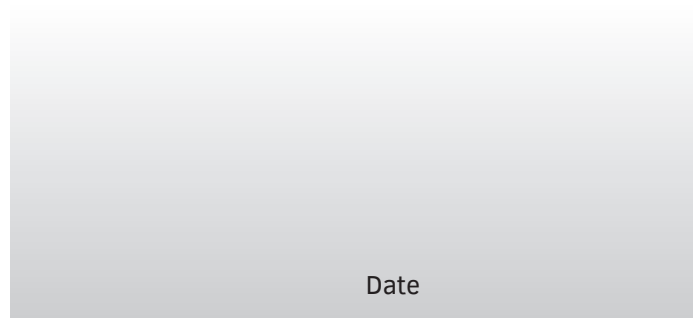

Date



INSTRUCTION MANUAL

48 Months

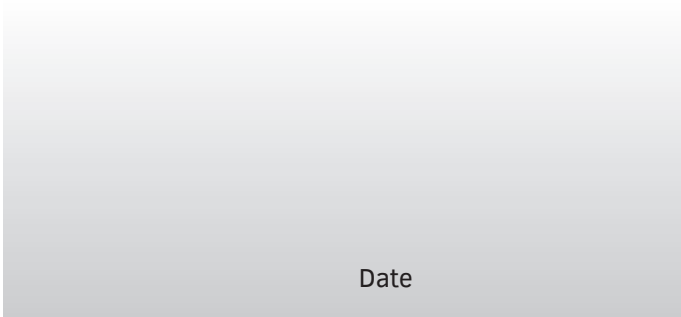

60 Months

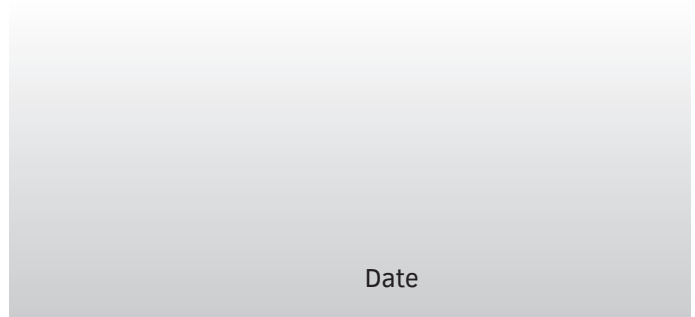

72 Months

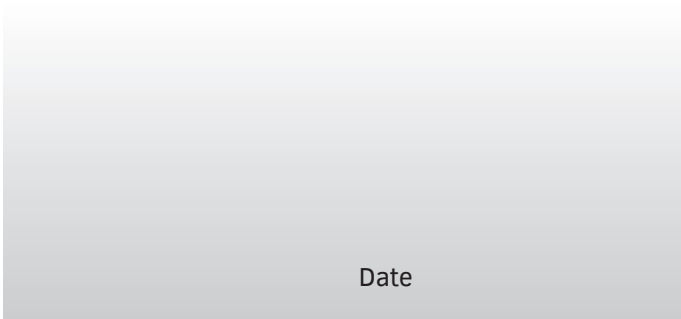

84 Months

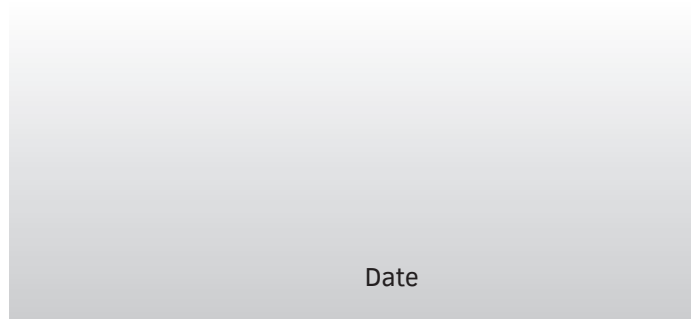

96 Months

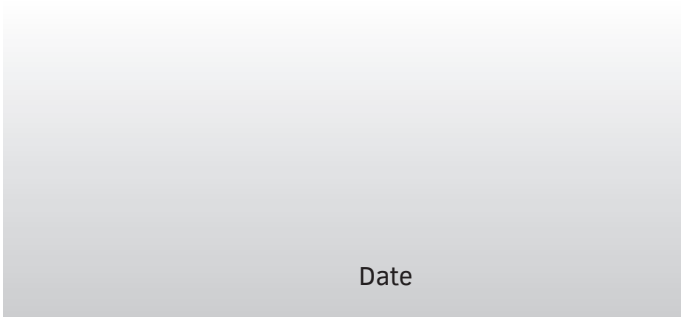

108 Months

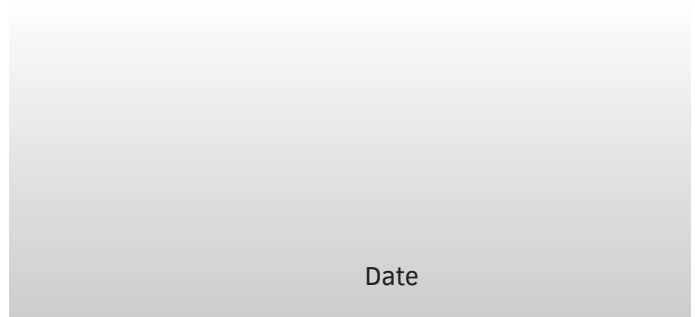

120 Months

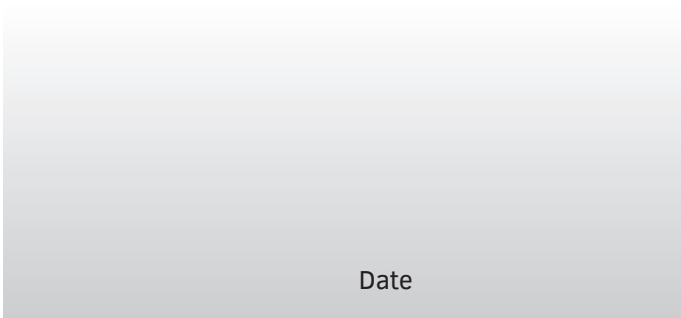

132 Months

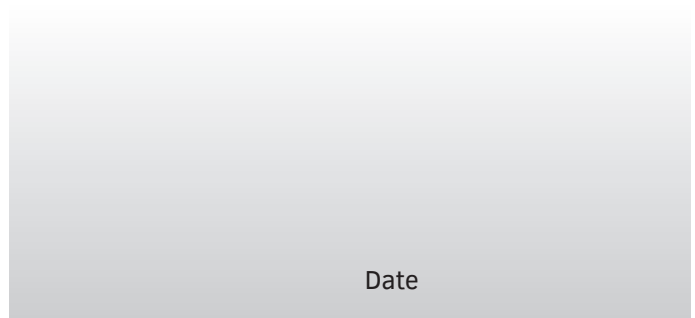

If you have registered online, this form is not necessary.
PLEASE POST THIS COPY TO THE ADDRESS OVERLEAF

Product Information (* Compulsory)

*Model No:	
*Product No:	
*Serial No:	
*Date of Purchase:	

Personal Information (* Compulsory)

*Title		*Forename		*Surname	
*House Number		*House Name			
*Address 1					
*Address 2					
*Town					
*County					
*Postcode					
Home Tel				Mobile Tel	
Email					

Age	18 to 25	26 to 35	36 to 45	46 to 60	61 to 80	81 & over
*Usage	Domestic Use			Commercial/Professional/Hire Use		

*Dealer Stamp (if available)



*Selling Retailer (If dealer stamp not available)

*Dealer Name	
*Dealer Address	
*Date of Purchase	

Webb Lawnmowers privacy commitment to machine owners.
The information supplied, helps us to improve the products & services we provide, including information that we believe is relevant to your and/or your machine. We value your trust by giving us this information about yourself and we are committed to protecting your privacy.

Webb, its associated companies, authorised dealers or third parties working on our behalf may wish to contact you regarding **PRODUCT RECALLS** specific to your machine. Please advise how you wish to be contacted for this specific reason only:

Post Telephone Email

From time to time Webb, its associated companies, authorised dealers or third parties working on our behalf may wish to contact you regarding our products, services, offers or just opinions, which may be used for marketing, research or analysis purposes.
If you wish to be contacted by any of the following methods, please tick the relevant boxes:

Post Telephone Email

You may give Webb Lawnmowers notice in writing at any time that you no longer wish to receive direct marketing communications

Webb Lawnmowers
Murdock Road
Dorcan
Swindon
Wiltshire
SN3 5HY