



36cm Petrol Tiller

WEPT360MM
1938216001

56cm Petrol Tiller

WEPT560MM
1938217001

en - Original Instructions

ASSEMBLY REQUIRED
Minimum Two Persons

Save these instructions
Sales & Support: 01793 333212

Before use please read & understand this manual; paying particular attention to the safety instructions before use.
Incorrect use of the product could put the operator or machine in danger.
Whilst every effort has been made to ensure the accuracy of information contained in this manual, our policy of continuous improvement determines the right to make modifications without prior warning.
Images are used for illustration purposes only.



INSTRUCTION MANUAL



4 June 21

Copyright Notice

Copyright © Handy Distribution

Permission is granted to reproduce this publication for personal & educational use only.

Commercial copying, redistribution, hiring or lending is prohibited.

No part of this publication may be stored in a retrieval system or transmitted in any other form or means without written permission from Handy Distribution.

In all cases this copyright notice must remain intact.

CONTENTS

INTENDED USE

SAFETY INSTRUCTIONS

SPECIFICATIONS

KNOW YOUR MACHINE

ASSEMBLY

OPERATION

MAINTENANCE, CLEANING & STORAGE

TROUBLE SHOOTING

PARTS DIAGRAM & LIST

DECLARATION OF CONFORMITY

WARRANTY

INTENDED USE

The basic version of the equipment is a scarifier intended for private use, i.e. for use in home and gardening environments. The tiller is designed for cultivating medium to large vegetable gardens, flower beds or allotment plots. Turning and loosening the soil.

Tillers for private use machines whose annual operating time generally does not exceed 10 hours, during which the machine is primarily used to maintain small-scale, residential gardens or allotments. Public facilities, sporting halls, and agricultural / forestry applications are excluded.

These operating instructions must be kept and referred to in order to ensure that the equipment is properly used and maintained. The instructions contain valuable information on operating, maintenance and servicing conditions.



WARNING

Due to the high risk of bodily injury to the user, the equipment may not be used to remove turf.

For safety reasons, the tiller may not be used as a drive unit for other equipment or toolkits of any kind, unless specifically advised to do so by the manufacturer.

The equipment is to be used only for its prescribed purpose. Any other use is deemed to be a case of misuse. The user/operator and not the manufacturer will be liable for any damage or injuries of any kind caused as a result of this.

Please note that our equipment has not been designed for use in commercial, trade or industrial applications. Our warranty will be 90 days from the original date of sale for commercial, trade or industrial businesses or for equivalent purposes.



INSTRUCTION MANUAL

SAFETY INSTRUCTIONS

Read and understand the owner's manual and labels affixed to the machine. Learn its application and limitations as well as the specific potential hazards. Retain these instructions for future reference. The operator is responsible for following the warnings & instructions in this manual and on the product.

	<p>Read & understand operator's manual before using the machine. Failure to follow instructions could result in death or serious injury. Please keep in a safe place for future reference.</p>		<p>Always wear eye and ear protection</p>
	<p>Keep all bystanders & animals away from the machine during operation. If approached, stop the machine immediately.</p>		<p>Always wear gloves to protect your hands. SHARP ROTATING BLADES</p>
	<p>Risk of Carbon Monoxide Poisoning. Ensure working area is correctly ventilated.</p>		<p>Wear foot protection or sensible shoes when using the machine</p>
	<p>Fire Risk Fire and its vapors are extremely flammable & explosive. Fire or explosion can cause severe burns or death.</p>		<p>Do not expose to rain or damp conditions.</p>
	<p>No smoking</p>		<p>Do not use near a flame, or sparks</p>
	<p>Hot Surface. Running engines produce heat. Engine parts, especially the exhaust, become extremely hot. Severe thermal burns can occur on contact</p>		<p>Moving Parts Rotating parts can contact or entangle hands, feet, hair, clothing or accessories. Traumatic amputation or severe laceration can result</p>
	<p>Keep guards in place and in working order. Replace damaged, missing or failed parts before using it.</p>		<p>Safety alert symbol. Used to alert you to potential personal injury hazards. Obey all safety messages that follow this symbol to avoid possible injury.</p>
	<p>Indicates an imminently hazardous situation which, if not avoided, will result in serious injury</p>		<p>Indicates a potentially hazardous situation which, if not avoided, could result in serious injury</p>
	<p>Indicates a potentially hazardous situation which, if not avoided, may result in minor or moderate injury.</p>	<p>CAUTION</p>	<p>Used without the safety alert symbol indicates a potentially hazardous situation which, if not avoided, may result in property damage.</p>
	<p>CE Marking - the product meets demand and regulations set by the EU</p>		<p>Noise Level - See label on machine</p>

GENERAL SAFETY RULES



Before you put the machine into operation, you must read this instruction manual.



When using this machine, observe the following safety instructions to exclude the risk of personal injury or material damage. Please also observe the special safety instructions in the respective chapters. Where applicable, follow the legal directives or regulations for the prevention of accidents in relation to the use of this machine.



WARNING

When using petrol tools, basic safety precautions, including the following, should always be followed to reduce the risk of serious personal injury and/or damage to the unit.

TRAINING



The operator must receive proper training in the use, adjustment and operation of the machine, including prohibited operations.

1. Read the instructions carefully. Be familiar with the controls & proper use of the equipment. Spend time to familiarise yourself with your machine before each use.
2. Never allow children or people unfamiliar with these instructions to use the machine. Local regulations can restrict the operator age.
3. This machine is not intended for use by persons (including children) with reduced physical, sensory or mental capabilities, or lack of experience and knowledge, unless they have been given supervision or instruction concerning use of the machine by a person responsible for their safety.
4. Never work while people, especially children, or pets are nearby.
5. Keep in mind that the operator or user is responsible for accidents or hazards occurring to other people or their property.

SAFETY INSTRUCTIONS FOR WORKING WITH TILLER

1. Do not leave engines running in enclosed spaces, where dangerous carbon monoxide could accumulate.
2. Operate in daylight or good artificial lighting. If possible, do not use on overly wet ground.
3. Ensure good stability on slopes. Always operate across the slope, never up and down.
4. Be particularly careful if changing direction of travel on the slope.
5. Do not operate on steep slopes.
6. Operate whilst walking, do not run.
7. Be particularly careful when you turn or when you pull the machine towards you.
8. Stop the engine and in turn the blade if it is to travel across other areas and must be transferred to/from working area.
9. Never use the machine with damaged safety protection guards.
10. Do not change the engine regulation set up.
11. Carefully start the engine. Keep your feet clear of the tines.
12. Never reach behind or under the rotating parts with hands or feet.
13. Never lift or carry the machine while the engine is on.
14. Switch the engine off and pull the spark plug connector out before unblocking or removing obstacles from the tines:
 - Before releasing blockages.



INSTRUCTION MANUAL

- Before inspecting, cleaning or working on the machine.
 - After hitting an obstruction. Before restarting, search for damage on the machine and make repairs as necessary. If the machine starts vibrating unusually, it should be inspected immediately by an Approved Webb Service Dealer.
15. Switch the engine off:
 - If you remove blockages from the machine.
 - Before refueling.
 16. When switching off the engine, the engine switch needs to be in position OFF (position OFF or O).

WORK AREA

1. Keep work area clean and well lit. Cluttered and dark areas invite accidents.
2. Check the landscape where the machine will be used and remove all objects such as stones, toys, sticks and wires, which could be caught and thrown away from the work area. Damage of the machine or operator's injury could be caused.
3. Do not operate this machine in explosive atmospheres, in the presence of flammable liquids, gases or dust. Machines create sparks which may ignite the dust or fumes.
4. Keep children & bystanders away while operating the machine. Distractions can cause you to lose control.

PERSONAL SAFETY

1. This machine is not intended for use by persons (including children) with reduced physical, sensory or mental capabilities, or lack of experience and knowledge, unless they have been given supervision or instruction concerning use of the machine by a person responsible for their safety.
2. Children should be supervised to ensure that they do not use or play with the machine.
3. Stay alert, watch what you are doing and use common sense when operating this machine.
4. Do not use this machine while you are tired, ill or under the influence of drugs, alcohol, or medication. A moment of inattention while operating this machine can cause you to lose control & may result in serious personal injury.
5. Do not overreach. Always keep proper footing and balance. This enables better control of the tool in unexpected situations.
6. Remove any adjusting tools before turning the machine on. A tool that is left attached to a rotating part of the machine may result in personal injury.
7. Use safety equipment. Always wear eye protection. Safety equipment such as a dust mask, non-skid safety shoes, hard hat, or hearing protection used for appropriate condition will reduce personal injuries.
8. Dress properly. Do not wear loose clothing or jewellery. Keep your hair, clothing & gloves away from moving parts. Loose clothes, jewellery or long hair can be caught in moving parts.
9. Prolonged use of the machine may lead to disorders of blood circulation in hands caused by vibration. These effects can be worsened by low ambient temperatures and/or by gripping the handgrips excessively tightly. Period of use you can extend with appropriate gloves or regular breaks. Take frequent work breaks. Limit the amount of exposure per day.

PETROL TOOL USE AND CARE



WARNING!

Petrol is highly flammable and explosive.

1. Store petrol in containers specifically designed for this purpose.
2. Refuel outdoors only and do not smoke while refueling.
3. Add fuel before starting the engine. Never remove the cap of the tank or add petrol while the engine is running or when the engine is hot.
4. If petrol is spilled, do not attempt to start the engine but move the machine away from the area of spillage and avoid creating any source of ignition until petrol vapors have dissipated.
5. Replace fuel tank & container caps securely.

6. Do not operate the engine in a confined space where dangerous carbon monoxide can collect.
7. Do not force the machine. Use the correct machine for your application. The correct machine will do the job better and safer at the rate for which it was designed.
8. Do not use the machine if the main ON/OFF switch does not work. Any machine that cannot be controlled with the main ON/OFF switch is dangerous and must be repaired.
9. Turn machine off completely before making any adjustments, changing accessories, or storing. Such preventive safety measures reduce the risks of starting the petrol tool accidentally.
10. Store idle machines out of the reach of children and do not allow persons unfamiliar with the machine or these instructions to operate. Petrol machines are dangerous in the hands of untrained users.
11. Maintain your machine. Check for misalignment or binding of moving parts, breakage of parts & any other condition that may affect the operation. If damaged, have the machine repaired by an Approved Webb Service Dealer immediately. Many accidents are caused by poorly maintained machines.
12. Use the machine, accessories and tool bits etc., in accordance with these instructions and in the manner intended for the particular type of petrol machine, taking into account the working conditions and the work to be performed. Use of the machine for operations different from intended could result in a hazardous situation.

PERSON PROTECTION

1. In case of any injury always proceed in accordance with the principles of the first aid.
2. If someone is cut, cover the wound with a clean cloth & press hard to stop the flow of blood.
3. Do not let petrol or oil come in contact with your skin. Keep petrol and oil away from the eyes. If petrol or oil come into contact with the eyes, wash them immediately with clean water. If irritation is still present, see a doctor immediately.
4. Individuals with poor circulation who are exposed to excessive vibration may experience injury to blood vessels or the nervous system. Vibration may cause the following symptoms to occur in the fingers, hands or wrists: numbness, tingling, pain, stabbing sensation, alteration of skin colour or of the skin. If any of these symptoms occur, see a doctor.

Put safety first in the case of fire:

5. If fire comes from the engine or smoke appears from anywhere other than the exhaust vent, at first distance yourself from the product to ensure your physical safety.
6. Use a dry powder fire extinguisher on the fire to prevent it from spreading.
7. A panicked reaction could result in the fire and other damage becoming more extensive.



INSTRUCTION MANUAL

SPECIFICATIONS

Model	WEPT360MM	WEPT560MM
Product Number	1938216001	1938217001
Working Width	360mm	560mm
Working Depth	130mm	
Wheel Size	6in	
Engine	Petrol, 4-Stroke Air Cooled	
Engine Displacement	161cc	
Engine Power (Max)	2.9kW / 3000rpm	
Gross Torque (NM)@2600rpm	10	
Full Tank Capacity	1.3L	
Oil Tank Capacity	0.45L	
Recommended Spark Plug	F7RTC or BPR5ES	
Measured Sound (L _{WA})	93dBA	
Guaranteed (L _{WA})	93dBA	
Weight	30kg	34kg

The manufacturer reserves the right to change the product specification and livery according to continued product improvements.



KNOW YOUR MACHINE

1. Clutch Lever	2. Handle
3. Clutch Cable	4. Throttle Lever
5. Engine Speed Adjustment Cable	6. Drag Bar
7. Fender (Extended for 560MM)	8. Tine Assembly (Extra Set For 560MM)
9. Gearbox	10. Transport Wheel
11. Recoil Starter	12. Fuel Tank Cap
13. Air Filter Housing	14. Oil Filler Cap & Dipstick
15. Exhaust (Muffler)	16. Spark Plug

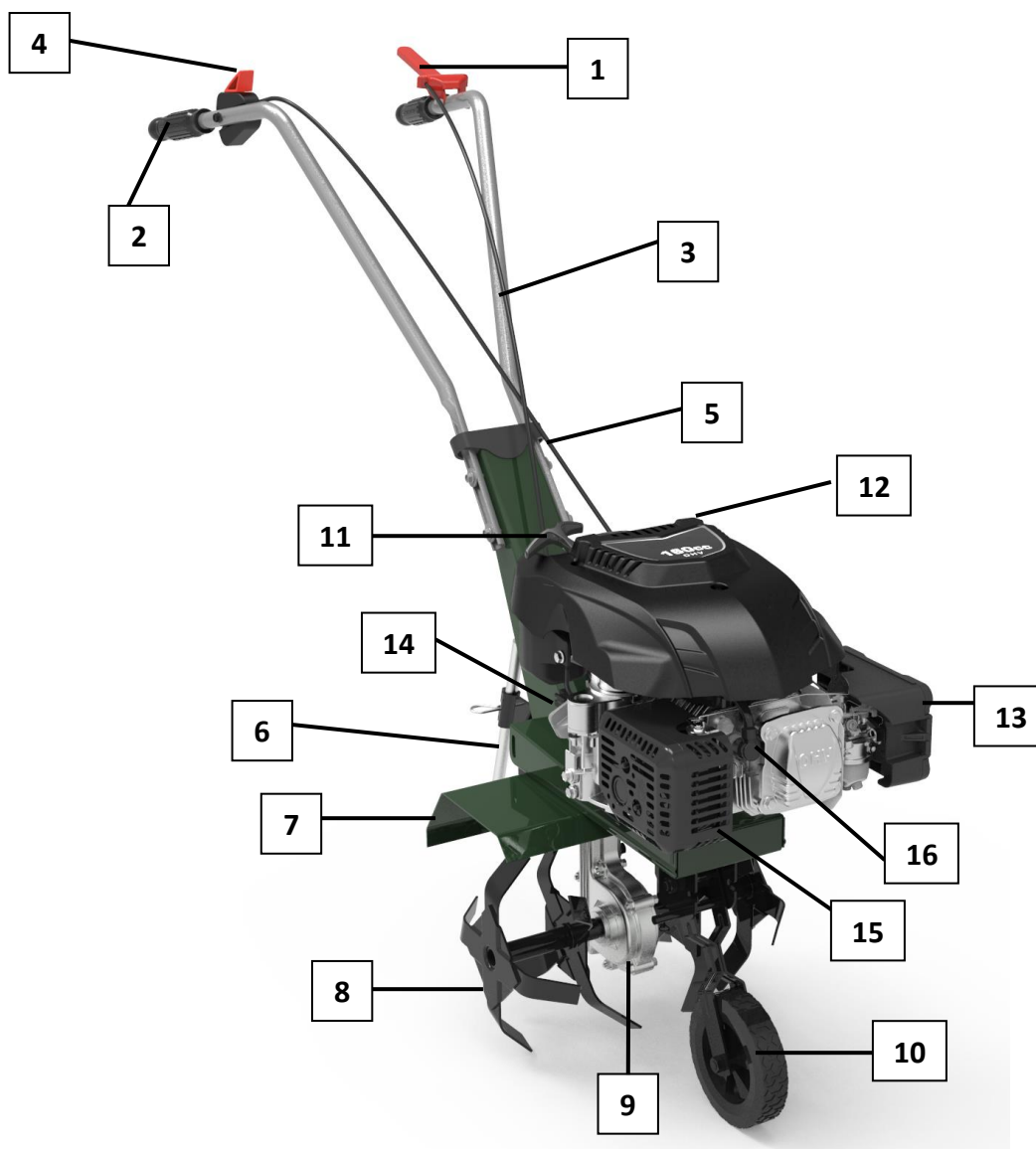



INSTRUCTION MANUAL

ASSEMBLY

Remove the machine and contents from the carton. Be sure the carton is empty before discarding.

If you require any assistance with regards to the contents of the machine, contact us:

Tel: 01793 333212 - Mon – Fri 8.00am – 5.30pm (excl. Bank Holidays)

Email: customerservice@webbgardenpower.co.uk

IMPORTANT INFORMATION

NOTE: This product is a 4-stroke engine powered Tiller.

The engine **MUST** be filled with recommended 4-stroke SAE30 or 10W/30 air cooled lawnmower engine oil **BEFORE** starting. Fresh unleaded fuel must be used in this unit. **DO NOT** use Ethanol based fuels. **DO NOT** mix oil with fuel.



WARNING

Stop the engine and unplug the spark plug before any repairs or maintenance operations.

DO NOT attempt to start this machine without it first being **FULLY** assembled.

DO NOT attempt to start this mower without first adding 4-stroke SAE30 or 10W/30 air cooled lawnmower engine oil to the engine.

FRONT WHEEL

- Pull the front wheel downward so that the front wheel can rotate freely, then lift the front wheel bracket to a proper position and the front wheel bracket will be fixed automatically by the spring. The tiller can stand with no other support.

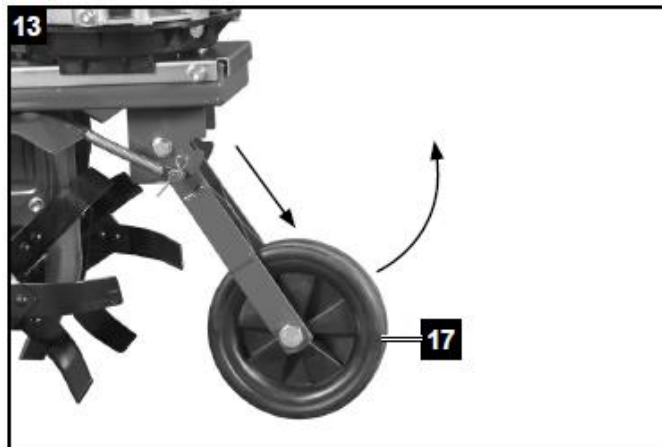

HANDLE BAR

- Attach the handle bar to the handle bar support properly to align the assembly holes (x2) and then fix with M8x45 bolt, washer & nut.

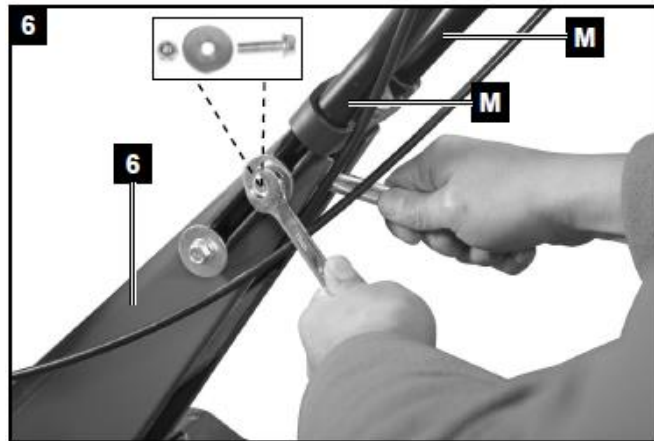

DRAG BAR

- First attach the drag bar to the drag bar holder, choose a proper height and then lock the drag bar with R-type locking pin.

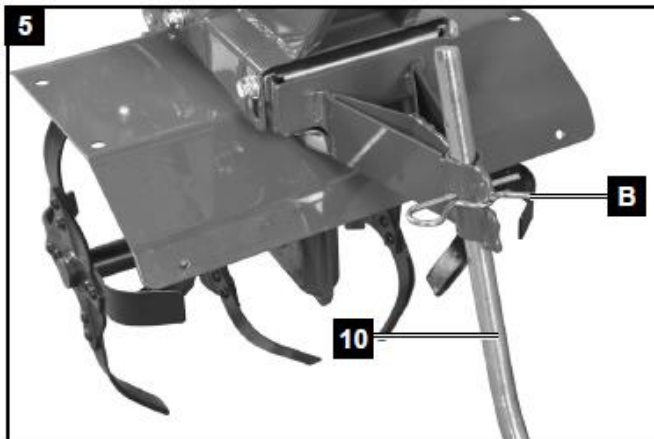

EXTRA TINES - (WEPT560MM ONLY)

- Mount extra tines to the axle and secure with the R-Clip.

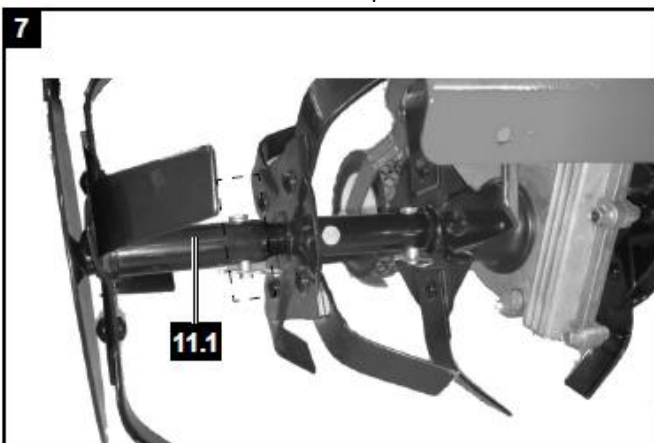



INSTRUCTION MANUAL

FENDER EXTENSION - (WEPT560MM ONLY)

- Mount the fender extension to the fender and secure using nut and bolt.

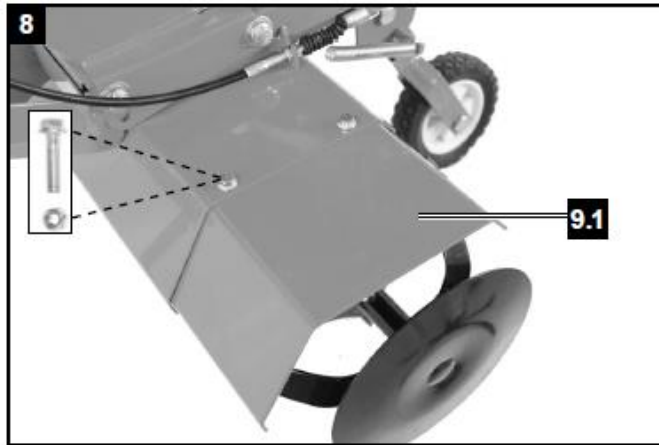

THROTTLE LEVER

- Mount the throttle lever to the right handle and secure with the bolt and nut supplied.

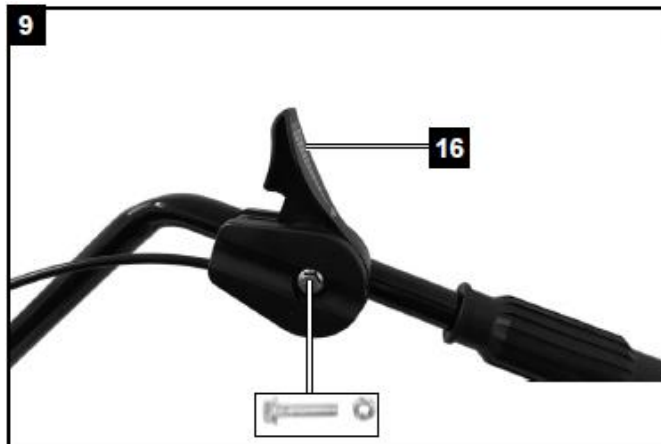

OPERATION

FUEL & OIL



WARNING

YOUR MACHINE IS SUPPLIED WITHOUT ENGINE OIL OR PETROL

Operating the engine with insufficient oil within your fuel mixture, can have catastrophic consequences. Any failure caused by insufficient oil, will not be covered by the manufacturer's warranty.

Read instructions carefully.

If you are not in receipt of your engine manual at any time, contact us prior to starting the engine.



Fuel & its vapors are very flammable. Do not use or fuel the machine near a flame, sparks or while smoking.

Allow the engine to cool for more than 3 minutes, before re-fueling. Never fuel the machine with engine running. Fuel the engine at least 15 metres away from your work area. Always fuel your machine outdoors.

IMPORTANT:

Fuel which is older than 30 days old can become stale and cause acid & gum deposits in the fuel system or essential carburettor components. This could result in starting issues which would not be covered by your manufacturer's warranty.

Ensure that any stored petrol/oil mixture is clearly marked in a separate appropriate canister for a maximum of 4-6 weeks if not mixed with a fuel additive. If the machine is not going to be used for a long period, drain the mixture from the fuel tank, start the engine and drain the carburettor of any remaining fuel. (See Engine manual for further instruction).

To keep fuel fresh, we recommend you use SURE-START FUEL ADDITIVE (HP-199) from Handy Parts. A fuel additive added to your fuel at the time of mixture, will help make your machine easier to start, extend the shelf life of your fuel mixture for up to two years, keeps the carburettor & engine clean, plus reduces emissions and increases fuel economy. A 250ml bottle of SURE-START FUEL ADDITIVE will treat 25 litres of fuel mix. Only use 4-stroke SAE30 or 10W/30 air cooled lawnmower engine oil. **DO NOT USE** automotive or marine oil.

FUELING THE MACHINE

Place the machine onto a solid flat surface, ensuring the engine is not running.

Unscrew the fuel cap slowly and fill the fuel tank unleaded petrol with an Octane rating of 86 or higher. Fill to a maximum of 80% capacity. This will allow the fuel tank to expand. Fasten the fuel cap tightly (2), being careful not to cross-thread. This will also prevent loosening through vibration during use. Wipe away any spillage, with an appropriate material. If the machine has continued leaks, the product should not be started. Never use the machine with damaged ignition cable or spark plug cap, as there is a risk of sparks.

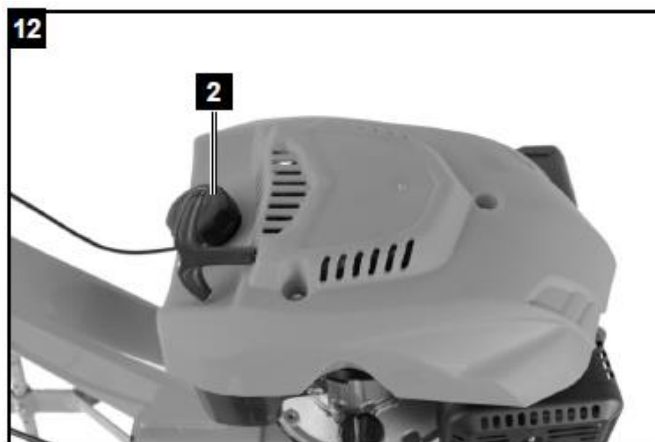



INSTRUCTION MANUAL

ENGINE OIL

Remove the oil filler cap with built in dipstick. Fill the engine with 4-stroke SAE30 or 10W/30 air cooled lawnmower engine oil. **DO NOT USE** automotive or marine oil. The use of a funnel will aid the filling. The engine capacity is 0.45L, however we recommend the dipstick on the oil filler is dipped (without screwing into the filler neck) to ensure the oil level remains between the minimum and maximum marks on the dipstick.

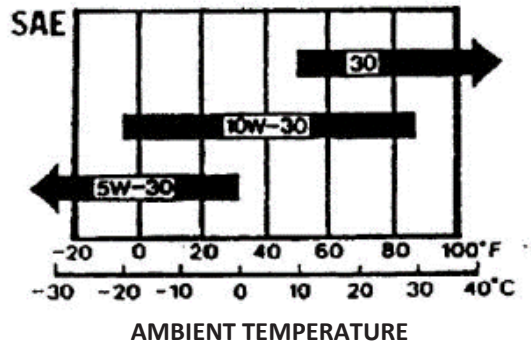
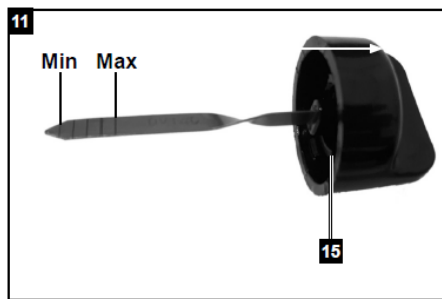

ENGINE STARTING & STOPPING PROCEDURE

STARTING THE ENGINE

- Move the engine throttle lever to the ON position (A).

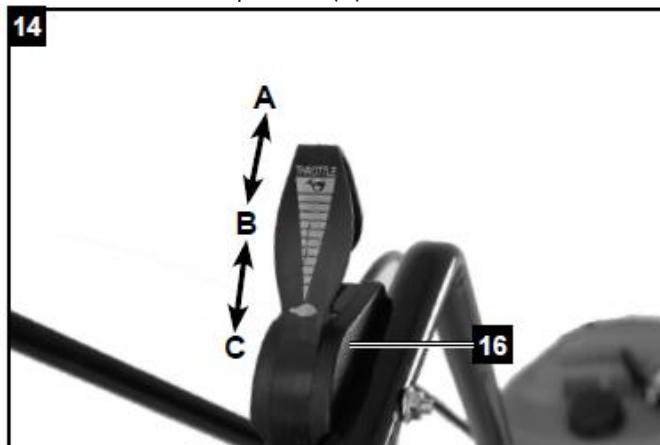

- Grab the recoil starter handle and pull lightly until resistance is felt, then pull rapidly.

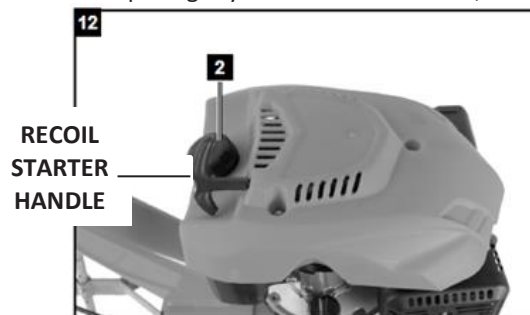

CAUTION

Do not allow the starter grip to snap back against the engine. Return it gently to prevent damage to the starter.

RUN/OPERATING POSITION

- As the engine warms, gradually move the throttle lever to the RUN position (B).

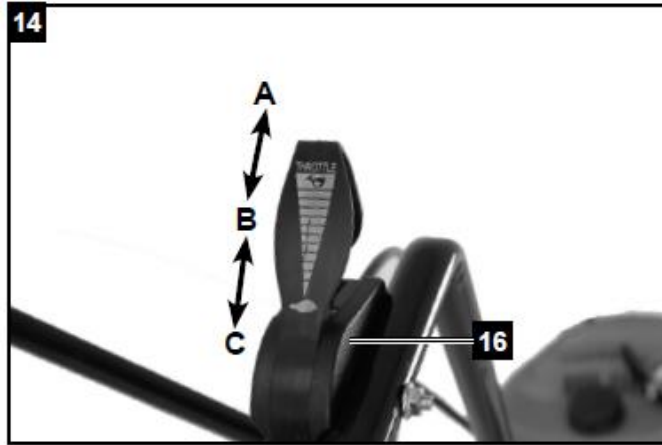

STOP POSITION - IN AN EMERGENCY

- Turn the throttle lever to the "STOP" position (C).

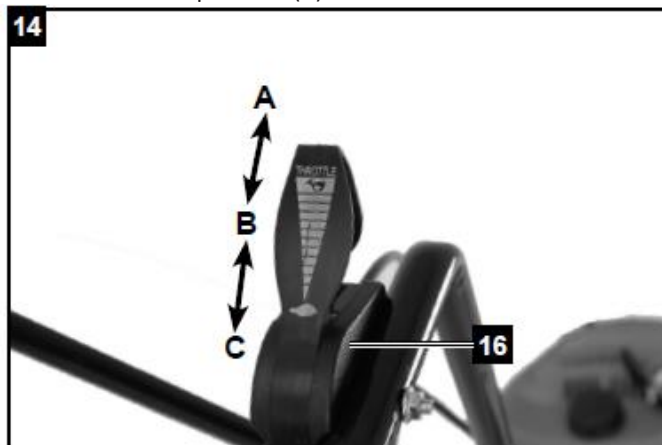

STOP POSITION - IN NORMAL USE

- Release the clutch lever to DISENGAGED position and let throttle lever to "STOP" position.

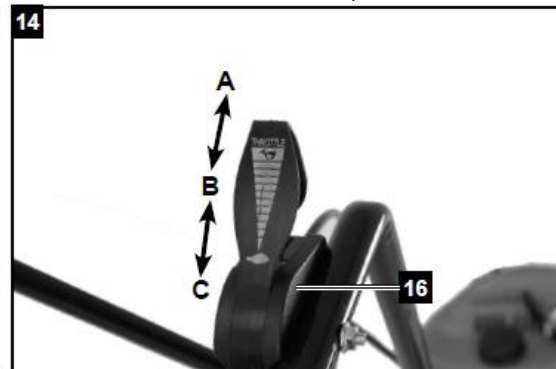
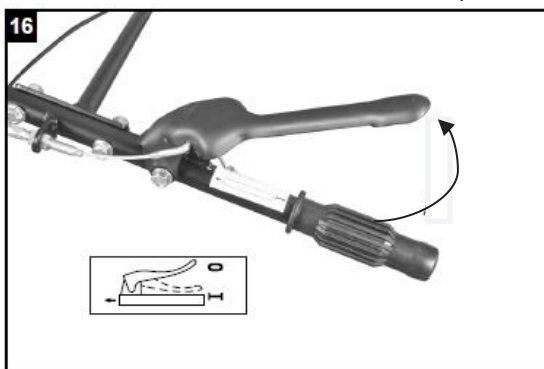



INSTRUCTION MANUAL

TILLER HEIGHT ADJUSTMENT



CAUTION

Before adjusting the handle, place the tiller on firm level ground to prevent the handle from collapsing accidentally.

- To adjust the tiller height, loosen the adjuster, select the appropriate hole and tighten the adjuster.

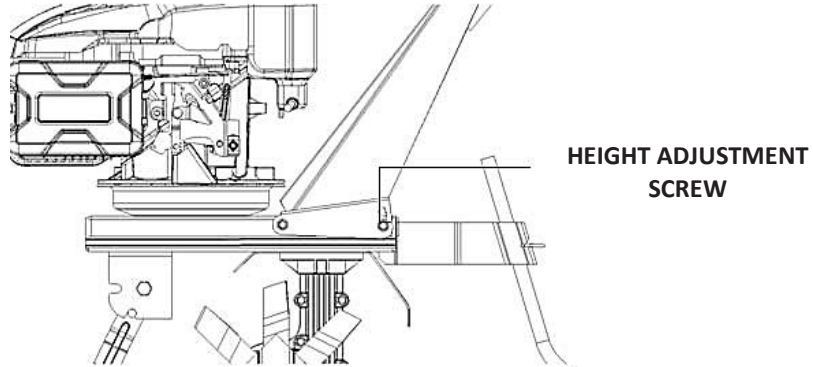

TILLER DEPTH ADJUSTMENT

- Install the hitch attachment in the hitch box with a hitch pin.
- The tilling depth adjustment can be made as follows:
- Remove the hitch bar locking pin, sliding the drag bar up or down as necessary.

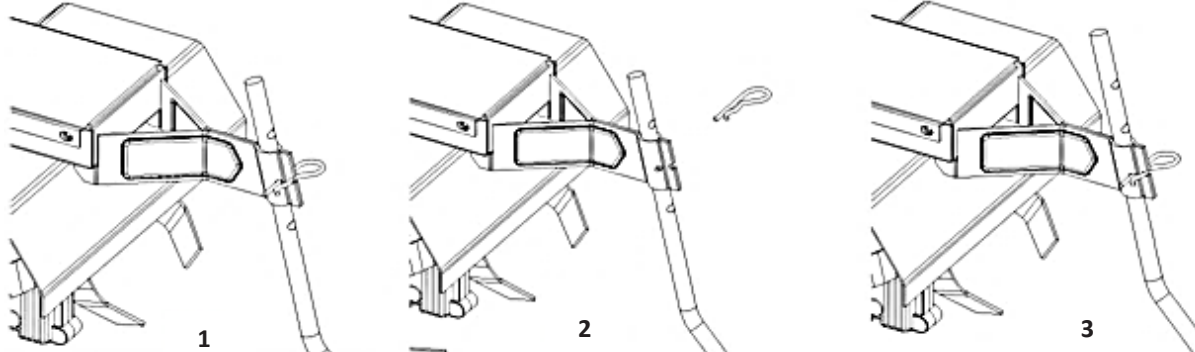

CLUTCH LEVER

- The clutch engages and disengages the power from the engine to the transmission.
- When the clutch lever is squeezed, the clutch is engaged, and power is transmitted. Squeeze the lever, the tines will be rotated.
- When the lever is released, the clutch is disengaged and power is not transmitted, release the clutch lever, the tool will be stopped.

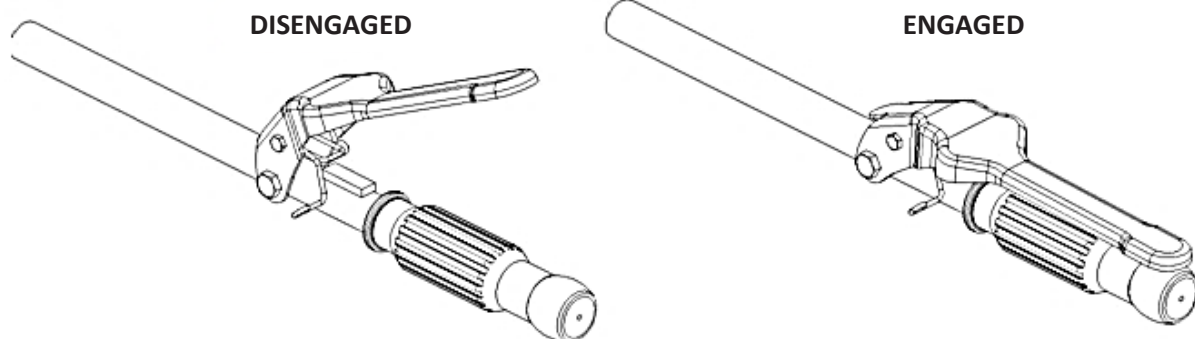

FRONT WHEEL

- Move the tiller to the work area with the front wheel, lift the handlebars up and ground the front wheel.
- When the tiller is used cultivate, move the wheel up.
 1. pull the front wheel downward
 2. lift the front wheel up to proper position

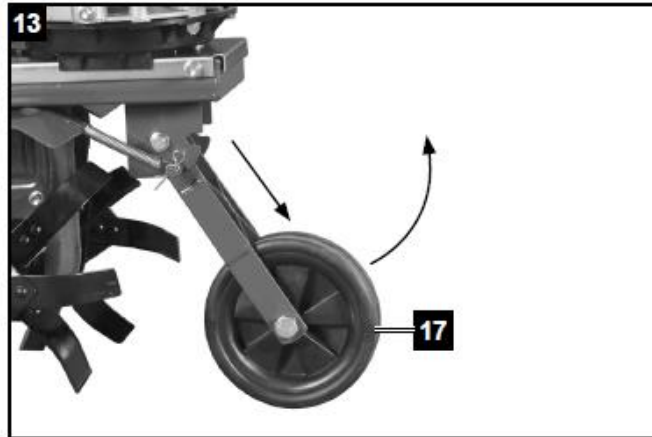

HANDLING TIPS

- Adjust the handlebar height to a comfortable position (usually waist height is recommended).
- If the machine jerks forward while tilling, press downwards on the handlebars; if the machine will not move forward, move the handlebars from side to side.

Turn: The proper method of negotiating a turn is to lower the handlebars to make the gravity of the tiller move backward-centre, towards the rear and then make the turn. This will permit a turn with relative ease.



CAUTION

Operating the tiller on gradients could cause the tiller to tip over.

Allowing anyone to operate this tiller without proper instruction may result in injury.

Wear sturdy, full coverage footwear. Operating this tiller with bare feet, or with open toe shoes or sandals increases your risk of injury.

Do not use the tiller at night or in poor light.

Be sure to transport the tiller from one place to another by two people, if a carrier is not available.

When the tines are clogged with mud, stones etc, immediately stop the engine and clean the tines in a safe place.

Be sure to wear heavy gloves when cleaning the tines.

To prevent damage, check the tiller for any signs of damage or other faults when the tiller is operated.



INSTRUCTION MANUAL

MAINTENANCE, CLEANING & STORAGE



WARNING

Improper maintenance & storage of the machine may void your warranty. Keep the machine clean for better and safer performance.

Turn off the engine before performing any maintenance. If the engine must be run, make sure the area is well ventilated. The exhaust emits dangerous carbon monoxide gases.

MAINTENANCE

- Before each use, check all nuts & bolts to be sure they are sufficiently tightened.
- We recommend only manufacturer original parts are used when maintaining this machine. Failure to do so could invalidate your manufacturer's warranty.
- The engine must be switched off, with the spark plug cap removed, before the machine is unassembled, cleaned, serviced or maintained.

SPARK PLUG

- Use only original replacement spark plug. For best results, replace the spark plug every 100 hours of use.
- Do not attempt to remove the plug from a hot engine in order to avoid possible damage to the threads.
- Clean or replace the plug if fouled with heavy oily deposits. Recommended gap of the spark plug electrode is 0.70-0.80mm.
- Replace the plug if the center electrode is worn or rounded at the end.

LUBRICATION

- WHEELS - Lubricate the ball bearings in each wheel at least once a season with a light oil.
- ENGINE - Follow the separate engine manual for lubrication instructions.

		Daily	First Month or 20 Hours	Every 3 months or 50 Hours	Every 6 months or 100 Hours	Every Year or 300 Hours
Engine Oil	Check Level	0				
	Change		0		0	
Air Filter (1)	Check	0				
	Clean			0		
Fuel Strainer Cup	Clean				0	
Spark Plug	Clean or Readjust				0	
Tappet Clearance (2)	Check or Readjust					0
Fuel Tank & Strainer	Clean					0
Clutch Cable	Adjust		0		0	
Throttle Cable	Adjust					0
Belt Tension (2)	Adjust		0		0	
Fuel Line	Check		Every 2 years (Replace if necessary)			

NOTE:

1. Check more frequently when used in dusty areas.
2. These items should be serviced by an authorised dealer.

ENGINE OIL CHANGE

Drain the oil while the engine is still warm to assure rapid and complete drainage

1. Remove the oil filler cap and drain the oil.
2. Refill with the recommended oil and check its level.

Oil capacity: See Specification section of this manual.

Wash your hands with soap and water after touching used oil.

NOTE: Please dispose of used motor oil in a manner that is compatible with the environment. We suggest you put it in a sealed container to your local service for reclamation. Do not throw it away into the refuse collection or pour it on the ground or in drains.

AIR FILTER

A dirty air filter will block air flow into the carburettor. To prevent carburettor malfunction, service the air filter regularly. Service more frequently when operating the engine in extremely dusty areas.



WARNING

Never use gasoline or low flash point solvents to clean the air cleaner element. A fire or explosion could occur.



CAUTION

Never run the engine without air filter or rapid engine wear will be the result.

1. Remove the wing nut and the air cleaner cover. Remove the filters and separate them if fitted with a foam and paper versions. Carefully check both for holes and tears and replace it if damaged.
2. **Foam element (if fitted):** clean in warm soapy water, rinse and allow to dry thoroughly or clean in high flash-point solvent and allow to dry. Dip the element in clean engine oil and squeeze out all the excess. The engine will smoke during initial start-up if too much oil is left in the foam.
3. **Paper element (if fitted):** Tap the element lightly several times on a hard surface to remove excess dirt or blow compressed air through the filter from the inside out. Never try to brush the dirt off, doing so will force dirt into the fibres.

GEARBOX

The gearbox does not need any maintenance; factory have confirmed oil will last lifetime of gearbox. Should the gearbox be replaced, fill the gearbox with 200ml of SAE 85W-90 gearbox oil.

SPARK PLUG

Recommended spark plug: BPR5ES (NGK) or F7RTC (LG)

To ensure proper engine operation, the spark plug must be properly gapped and free of deposits.

1. Remove the spark plug cap.



WARNING

If the engine has been running, the exhaust (muffler) will be very hot. Be careful not to touch the exhaust (muffler).

2. Visually inspect the spark plug. Discard it if the insulator is cracked or chipped.



INSTRUCTION MANUAL

3. Measure the plug gap with a feeler gauge. The gap should be 0.7-0.8mm (0.028-0.031 in), correct as necessary by bending the side electrode.

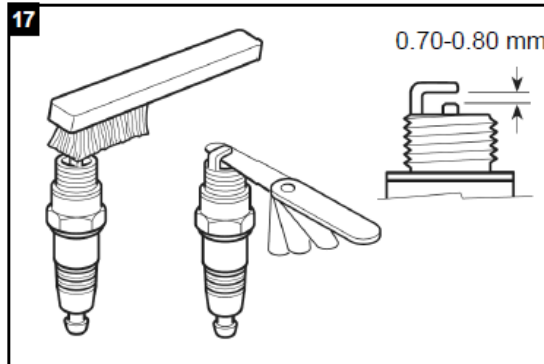

4. Attach the plug washer, thread the plug in by hand to prevent cross-threading.
5. When mounting a new spark plug, you should screw 1/2 more thread with the wrench after the washer is compressed. If you are mounting an old one, you should only screw 1/8-1/4 more thread.



CAUTION

The spark plug must be securely tightened. An improperly tightened plug can become very hot and possibly damage the engine. Never use a spark plug with an improper heat range.

CLEANING



CAUTION

Do not use a water hose or pressure washer to clean the engine. Water can damage the engine or contaminate the fuel system.

- Keep your machine clean. Thoroughly clean the machine at the end of each use, paying attention to stones or mud in and around the tines.
- Clean the engine regularly with a cloth or brush. Keep the cooling system (blower housing area) clean to permit proper air circulation which is essential to engine performance and life. Be certain to remove all dust, dirt and combustible debris from exhaust area.

STORAGE & TRANSPORT

The following steps should be taken to prepare your lawn scarifier for storage.

1. Empty the tank.
 - a. Empty the petrol tank with a suction pump.



CAUTION

Do not drain the petrol in enclosed spaces, in close proximity of open fire, etc.
Do not smoke! Petrol fumes can cause explosion or fire.

- b. Start the engine and let it run until it has used up all remaining petrol and stalls.
 - c. Remove the spark plug. Use an oil can to fill approx. 20 ml oil into the combustion chamber. Operate the starter to evenly distribute the oil in the combustion chamber. Replace the spark plug.
2. Store in a dry, clean and frost-protected place, out of reach of unauthorised persons.



CAUTION

The engine must have completely cooled down before storing.

NOTE:

When storing any type of power equipment in an unventilated or material storage shed,

- Care should be taken to rust-proof the equipment. Using a light oil or silicone, coat the equipment, especially cables and all moving parts.
- Be careful not to bend or kink cables.
- If the starter rope becomes disconnected from rope guide on handle, disconnect and ground the spark plug wire. Depress the blade control handle and pull the starter rope out from engine slowly. Slip the starter rope into the rope guide bolt on handle.

DO NOT STORE fuel for longer than 30 days. Fuel can become stale and cause damage to the engine carburettor, which is not covered by the machines manufacturer's warranty.

TROUBLE SHOOTING

PROBLEM	POSSIBLE CAUSES	REMEDIAL ACTION
Engine does not start	Throttle choke is not in the correct position	Move throttle choke to correct position.
	Fuel tank is empty.	Fill tank with fuel: refer to ENGINE OWNERS MANUAL.
	Spark plug loose.	Tighten spark plug.
	Spark plug wire loose or disconnected from plug.	Install spark plug wire on spark plug.
	Spark plug gap is incorrect	Set correct gap between electrodes.
	Spark plug is defective.	Install new, correctly gapped plug.
	Carburettor is flooded with fuel.	Remove air cleaner element and pull starter rope continuously until carburettor clears itself and install air cleaner element.
Motor speed drops off	Depth of cultivation is too great	Set to smaller depth of cut
	Tines blocked	Pull out spark plug connector, remove blockage.
	Air filter clogged	Clean air filter: refer to relevant section in manual
Clutch not working	Engine speed is too low	Open throttle, increase engine speed.
	Belt too long	Replace - visit local approved service dealer
	Spring failure	Replace - visit local approved service dealer
	Bearing inside gearbox failed	Replace - visit local approved service dealer
Abnormal noise from gearbox	Faulty	Replace - visit local approved service dealer
Tines stop rotating	Belt has come off pulley	Refit belt to pulley - visit local approved service dealer.



INSTRUCTION MANUAL

PARTS DIAGRAM - WEPT360MM 1938216001

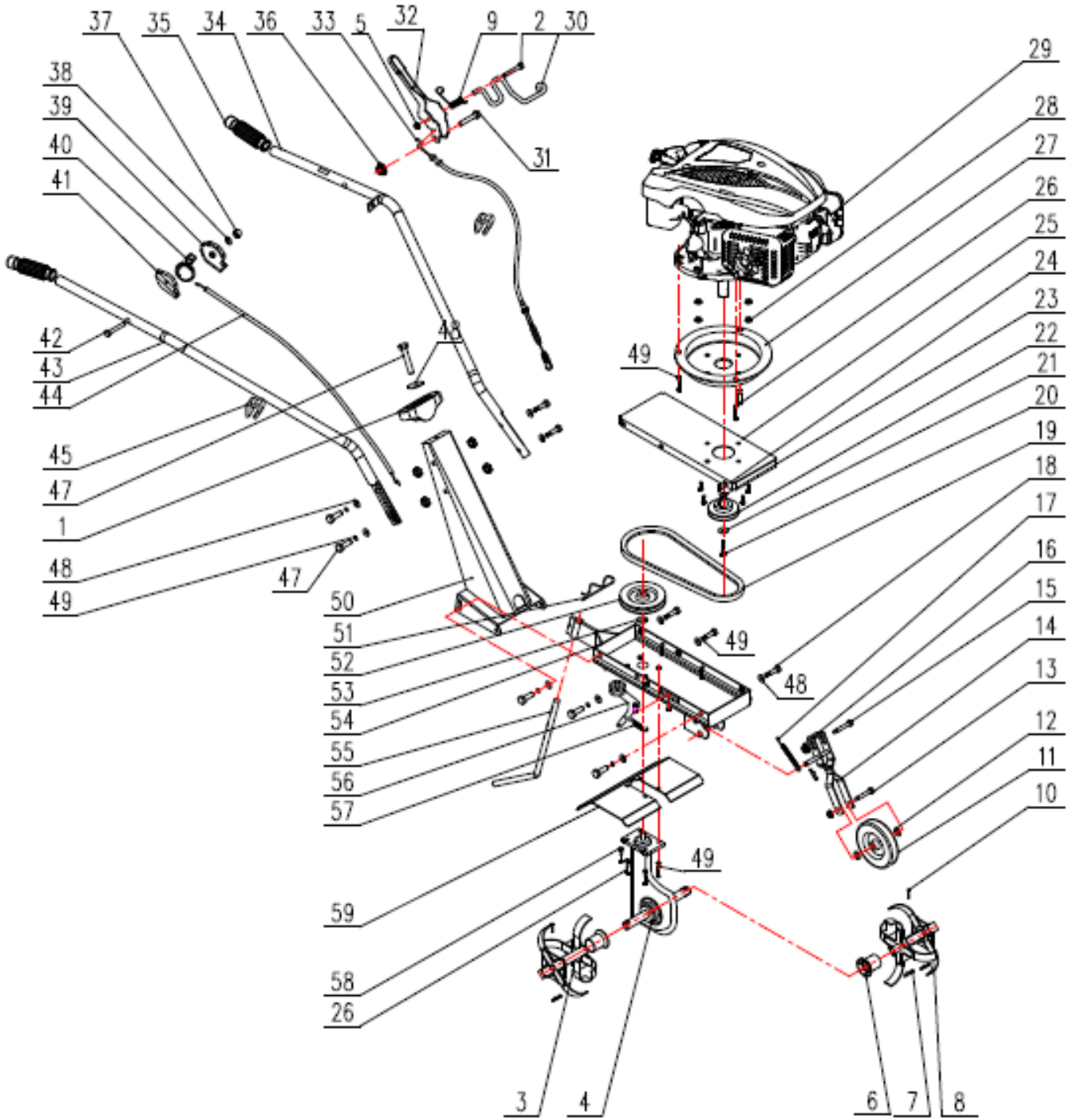

PARTS LIST - WEPT360MM 1938216001

Item No.	Webb Part No.	Description	Qty	Item No.	Webb Part No.	Description	Qty
1	WE149-661002	Handle Housing	1	31	WE149-91349	M8x40 Bolt	1
2	WE149-91441	M5x35 Bolt	1	32	WE149-661009-039	Clutch Lever	1
3	WE149-666005	Right Tine Assembly	1	33	WE149-661007	Clutch Cable	1
4	WE149-662001	Gearbox	1	34	WE149-661005-206	Left Handle	1
5	WE149-90063	M5 Nut	1	35	WE149-661004	Handle Grip	2
6	WE149-666002	Cover	2	36	WE149-90059	M8 Nut	1
7	WE149-816004	Circlip Φ 2	3	37	WE149-90043	M6 Nut	1
8	WE149-666006	Left Tine Assembly	1	38	WE149-94011	Washer Φ 12	1
9	WE149-661010	Clutch Spring	1	39	WE149-605031	Throttle Lever Cover (L)	1
10	WE149-91899	Clevis Pin with Head 8x35	2	40	WE149-605012-039	Throttle Lever	1
11	WE149-665003	Front Wheel	1	41	WE149-605032	Throttle Lever Cover (R)	1
12	WE149-94068	Nylon Washer	2	42	WE149-91869	M6x44 Bolt	1
13	WE149-665002	Bolt	1	43	WE149-661003-206	Right Handle	1
14	WE149-665001	Wheel Housing	1	44	WE149-661006	Throttle Cable	1
15	WE149-91888	M10x65 Bolt	1	45	WE149-605004	Cable Clip	2
16	WE149-90057	M10 Nut	2	46	WE149-91881	M8x16 Bolt	4
17	WE149-665005	Spring	1	47	WE149-91348	M8x35 Bolt	1
18	WE149-91346	M8x25 Bolt	10	48	WE149-94041	Washer Φ 8.4X24X2	11
19	WE149-662056	Belt VZ610	1	49	WE149-94040	Washer 8.1X2.1	17
20	WE149-91891	Bolt 3/8UNFX30	1	50	WE149-661001-333	Handle Base	1
21	WE149-94270	Washer Φ 10.5X30X2.5	1	51	WE149-666018	Circlip	1
22	WE149-662007	Small Pulley	1	52	WE149-662005	Large Pulley	1
23	WE149-94273	Washer Φ 10 (GB97)	1	53	WE149-94289	Washer Φ 13.2x Φ 24x1.5	1
24	WE149-296511	Flat Key	1	54	WE149-662038-333	Gearbox Base	1
25	WE149-662006-333	Belt	1	55	WE149-666003	Depth Gauge	1
26	WE149-91347	M8x30 Bolt	7	56	WE149-662003	Tension Pulley	1
27	WE149-663025	Engine Housing	1	57	WE149-662004	Spring	1
28	WE149-90018	M8 Nut	8	58	WE149-94057	Washer Φ 8	4
29	WE149-230016010021	Engine	1	59	WE149-663002-333	Fender	1
30	WE149-661011	Clutch Spring	1				



INSTRUCTION MANUAL

PARTS DIAGRAM - WEPT560MM 1938217001

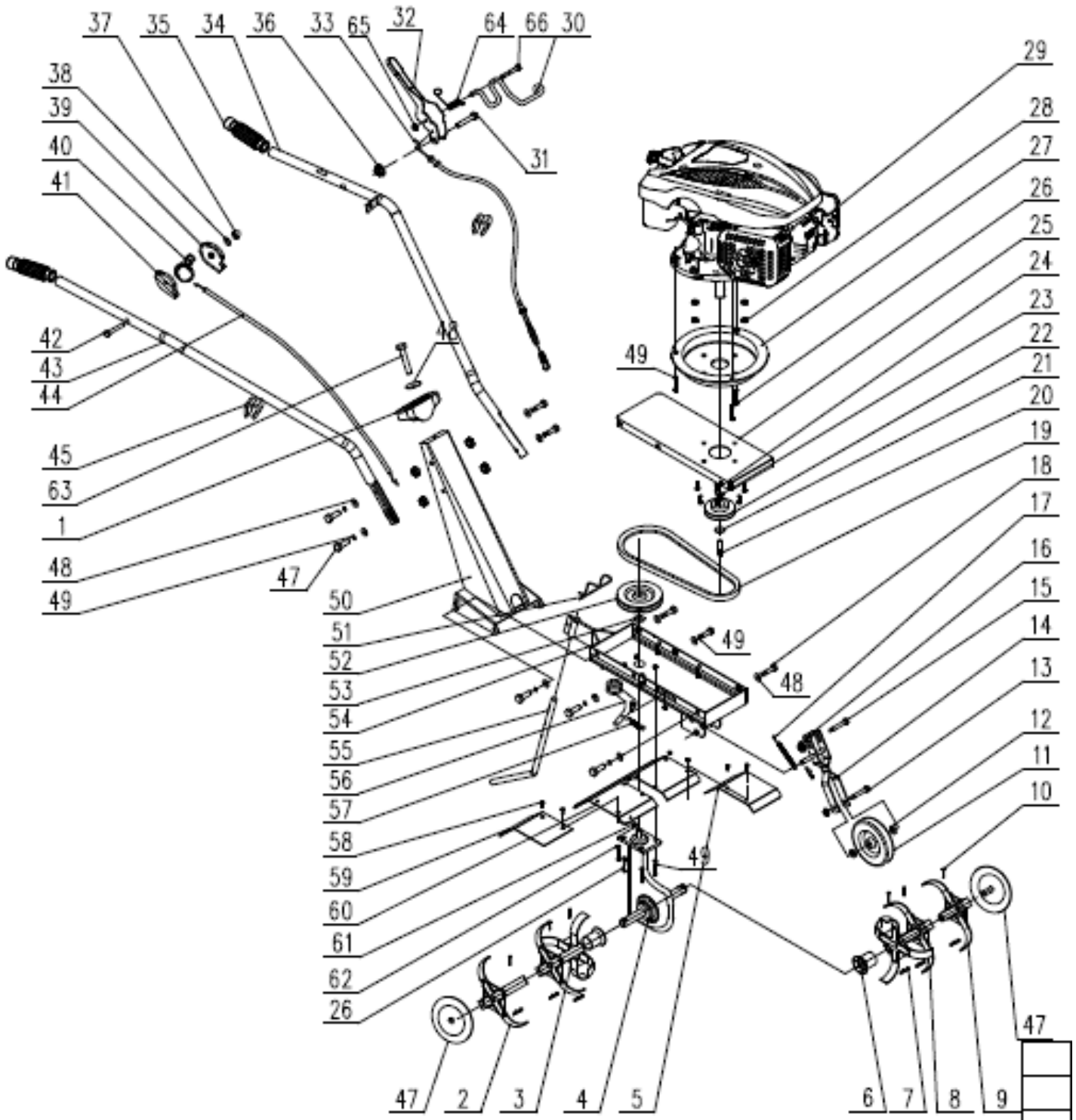

PARTS LIST - WEPT560MM 1938217001

Item No.	Webb Part No.	Webb Description	Qty	Item No.	Webb Part No.	Webb Description	Qty
1	WE149-661002	Handle Housing	1	34	WE149-661005-206	Left Handle	1
2	WE150-666007	Right Outer Tine	1	35	WE149-661004	Handle Grip	2
3	WE149-666005	Right Tine Assembly	1	36	WE149-90059	M8 Nut	1
4	WE149-662001	Gearbox	1	37	WE149-90043	M6 Nut	1
5	WE150-663004-333	Left Second Fender	1	38	WE149-94011	Washer Φ 12	1
6	WE149-666002	Cover	2	39	WE149-605031	Throttle Lever Cover (L)	1
7	WE149-816004	Circlip Φ 2	7	40	WE149-605012-039	Throttle Lever	1
8	WE149-666006	Left Tine Assembly	1	41	WE149-605032	Throttle Lever Cover (R)	1
9	WE150-666008	Left Outer Tine	1	42	WE149-91869	M6x44 Bolt	1
10	WE149-91899	Clevis Pin with Head 8x35	6	43	WE149-661003-206	Right Handle	1
11	WE149-665003	Front Wheel	1	44	WE149-661006	Throttle Cable	1
12	WE149-94068	Nylon Washer	2	45	WE149-605004	Cable Clip	2
13	WE149-665002	Bolt	1	46	WE149-91881	M8x16 Bolt	4
14	WE149-665001	Wheel Housing	1	47	WE150-666009	Tine Dish	2
15	WE149-91888	M10x65 Bolt	1	48	WE149-94041	Washer Φ 8.4X24X2	11
16	WE149-90057	M10 Nut	2	49	WE149-94040	Washer 8.1X2.1	17
17	WE149-665005	Spring	1	50	WE149-661001-333	Handle Base	1
18	WE149-91346	M8x25 Bolt	10	51	WE149-666018	Circlip	1
19	WE149-662056	Belt VZ610	1	52	WE149-662005	Large Pulley	1
20	WE149-91891	Bolt 3/8UNFX30	1	53	WE149-94289	Washer Φ 13.2x Φ 24x1.5	1
21	WE149-94270	Washer Φ 10.5X30X2.5	1	54	WE149-662038-333	Gearbox Base	1
22	WE149-662007	Small Pulley	1	55	WE149-666003	Depth Gauge	1
23	WE149-94273	Washer Φ 10 (GB97)	1	56	WE149-662003	Tension Pulley	1
24	WE150-296505	Flat Key 4.75X5.5X30	1	57	WE149-662004	Spring	1
25	WE149-662006-333	Belt	1	58	WE150-91329	M6X16 Bolt	4
26	WE149-91347	M8x30 Bolt	7	59	WE150-663003-333	Right Second Fender	1
27	WE149-663025	Engine Housing	1	60	WE149-663002-333	Fender	1
28	WE149-90018	M8 Nut	8	61	WE150-90016	M6 Nut	4
29	WE149-230016010021	Engine	1	62	WE149-94057	Washer Φ 8	4
30	WE149-661011	Clutch Spring	1	63	WE150-91348	M8x35 Bolt	1
31	WE149-91349	M8x40 Bolt	1	64	WE149-661010	Clutch Spring	1
32	WE149-661009-039	Clutch Lever	1	65	WE149-90063	M5 Nut	1
33	WE149-661007	Clutch Cable	1	66	WE149-91441	M5x35 Bolt	1



INSTRUCTION MANUAL

PARTS DIAGRAM - ENGINE

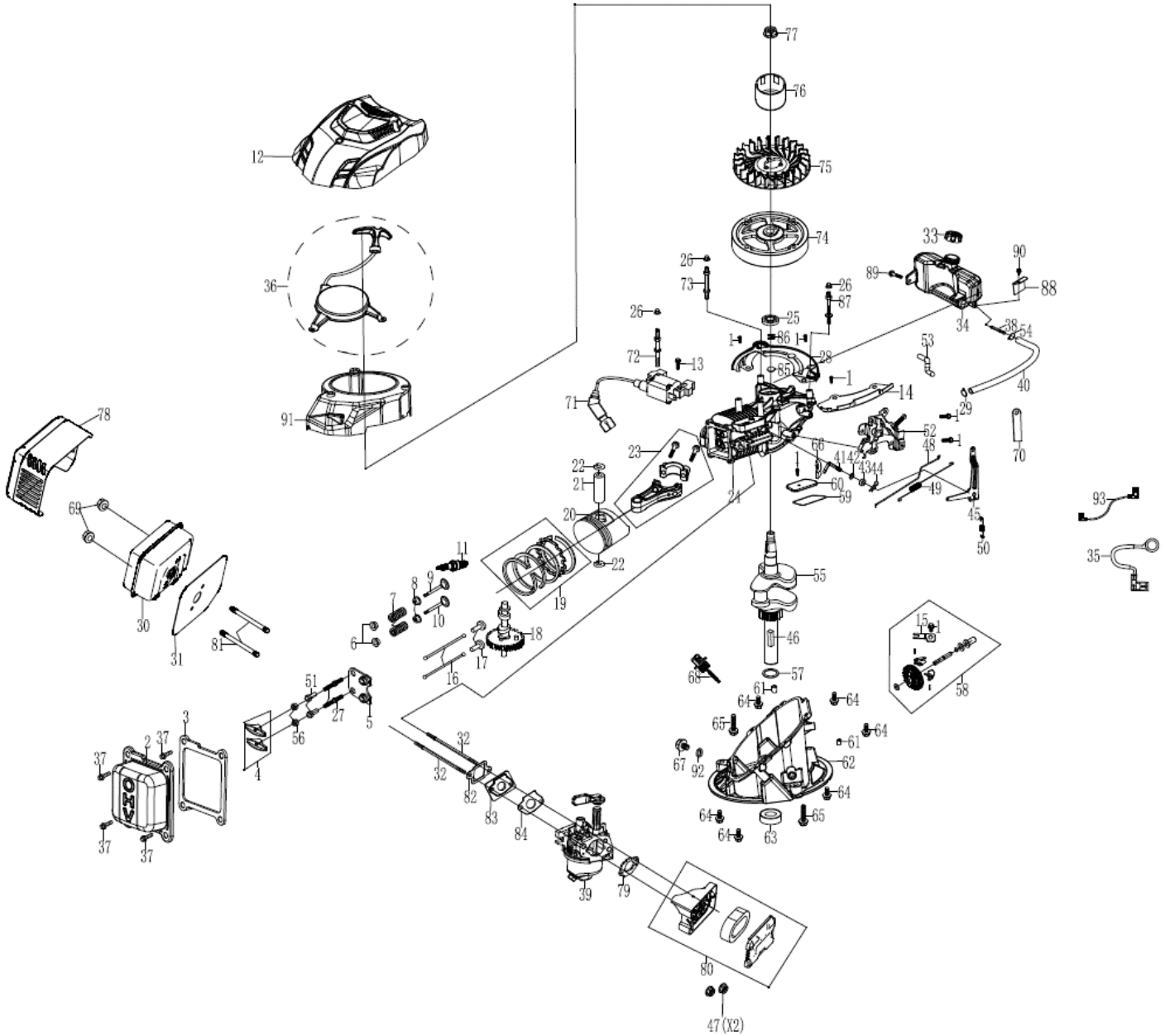

Item No	Webb Part No.	Description	Qty
1	WE151-91365	M6x12 Bolt	7
2	WE151-311101	Cylinder Head Cover	1
3	WE151-96161	Cylinder Gasket	1
4	WE151-312101	Rocker Arm	2
5	WE151-312201	Push Rod Guide Plate	1
6	WE151-311802	Valve Spring Seat	2
7	WE151-316001	Valve Spring	2
8	WE151-311801	Intake Valve Returner	2
9	WE151-311701	Intake Valve	1
10	WE151-315901	Exhaust Valve	1
11	WE151-97109	Spark Plug	1
12	WE151-294909-053	Engine Cover	1
13	WE151-91369	M6x25 Bolt	1
14	WE151-310502	Brake Assembly	1
15	WE151-314302	Governor Plate	1
16	WE151-311901	Push Rod	2
17	WE151-316101	Valve Lifter	2
18	WE151-312001	Camshaft Assembly	1
19	WE151-311602	Piston Ring Set	1
20	WE151-311201	Piston	1
21	WE151-315501	Piston Pin	1
22	WE151-291301	Piston Clip	2
23	WE151-311501	Connecting Rod Assembly	1
24	WE151-310202	Cylinder	1
25	WE151-93524	Oil Seal	1
26	WE151-90043	Flange Nut	3
27	WE151-91829	Rocker Arm Adjuster	2
28	WE151-300505	Shroud	1
29	WE151-94403	Fuel Pipe Clamp Φ 7.5	1
30	WE151-313701	Muffler Assembly	1
31	WE151-96131	Exhaust Gasket	1

Item No	Webb Part No.	Description	Qty
32	WE151-91038	Stud Bolt	2
33	WE151-293601-055	Fuel Cap Assembly	1
34	WE151-293206-055	Fuel Tank	1
35	WE151-296402	Earth Wire 1	1
36	WE151-294813-053	Recoil Assembly	1
37	WE151-91370	M6x16 Bolt	4
38	WE151-299901	Fuel Filter	1
39	WE151-312806	Carburettor Assembly	1
40	WE151-95457	Fuel Pipe	1
41	WE151-313901	Governor Arm Shaft	1
42	WE151-96808	Governor Arm Shaft Washer	1
43	WE151-93520	Governor Arm Shaft Seal	1
44	WE151-243902	Lock Pin	1
45	WE151-314001	Governor Arm	1
46	WE151-296507	Crankshaft Flat Key	1
47	WE151-90035	Flange Hex Bolt M6	2
48	WE151-312701	Governor Rod	1
49	WE151-314201	Throttle Return Spring	1
50	WE151-314104	Governor Spring	1
51	WE151-90036	Nut	2
52	WE151-314402	Upper Shroud Assembly	1
53	WE151-95626	Breather Tube	1
54	WE151-94415	Fuel Pipe Clip	1
55	WE151-310303	Crankshaft Assembly	1
56	WE151-90037	Nut	2
57	WE151-94225	Crankshaft Washer	1
58	WE151-314303	Governor Assembly	1
59	WE151-96162	Breather Chamber Gasket	1
60	WE151-310602	Breather Chamber Cap	1
61	WE151-310901	Dowel Pin	2
62	WE151-310102	Crankcase Cover Assembly	1

Item No	Webb Part No.	Description	Qty
63	WE151-93523	Oil Seal	1
64	WE151-91366	M6x18 Bolt	6
65	WE151-91367	M6x45 Bolt	2
66	WE151-310608	Breather Filter	1
67	WE151-91816	Drain Bolt	1
68	WE151-315601-138	Dipstick	1
69	WE151-90038	M6 Lock Nut	2
70	WE151-599601	Metal Clip	1
71	WE151-97566	Ignition Coil Assembly	1
72	WE151-91064	Ignition Coil Stud Bolt	1
73	WE151-91065	Recoil Stud Bolt 1	1
74	WE151-310402	Flywheel Assembly	1
75	WE151-304602	Recoil Starter Fan	1
76	WE151-304501	Starter Pulley	1
77	WE151-90003	Nut	1
78	WE151-312501	Muffler Shield	1
79	WE151-94228	Air Filter Gasket	1
80	WE151-292914	Air Filter Assembly	1
81	WE151-91039	Stud Bolt	2
82	WE151-96128	Intake Gasket	1
83	WE151-312301	Carburettor Insulator	1
84	WE151-96129	Carburettor Gasket	1
85	WE151-300605	Circular Plate	1
86	WE151-310606	Breather Valve Spring	1
87	WE151-91066	Recoil Stud Bolt 2	1
88	WE151-310505	Deflector	1
89	WE151-91329	M6x16 Disc Bolt	1
90	WE151-92007	M4x8 Screw	1
91	WE151-316302	Recoil Housing	1
92	WE151-94007	Drain Bolt Washer	1
93	WE151-316403	Earth Wire 2	1



EC DECLARATION OF CONFORMITY

We Handy Distribution Ltd - SN3 5HY (Importer) declare that the product:

Designation: Petrol 360mm Tiller
Model(s): WEPT360MM
Product No.: 1938216001
Type/Serial No. As per rating label on machine
Engine Displacement: 161 cm³
Rated Engine Power: 2.9 kW / 3600 rpm
Tilling Width: 360 mm

Complies with the following directives:

Machinery Directive 2006/42/EC

The conformity assessment procedure followed was in accordance with
EN 709:1997+A4:20019; EN 709:1997+A4/AC;

Noise Directive 2000/14/EC

Guaranteed Noise Power Level L_{WA}: 93 dB(A) - uncertainty: 2 dB(A) According to 2000/14/EC
Measured Sound Power: 93 dB(A)
Vibration a_{hv}: 13 m/s² - uncertainty K: 2 m/s²

Electromagnetic Compatibility Directive 2014/30/EC

The conformity assessment procedure followed was in accordance with
EN ISO 14982:2009

Notified Body:

TÜV Rheinland LGA Products GmbH

Addresses:

Tillystraße 2, 90431 Nürnberg, Germany

Authorised signatory and technical file holder

Date: 01/07/2019

Signature:

A handwritten signature in black ink, appearing to read "S Belcher", written over a horizontal line.

Name: Mr Simon Belcher

Position: Chairman

Company: Handy Distribution Ltd

Address: Murdock Rd, Swindon, Wiltshire, SN3 5HY.





EC DECLARATION OF CONFORMITY

We Handy Distribution Ltd - SN3 5HY (Importer) declare that the product:

Designation: Petrol 560mm Tiller
Model(s): WEPT560MM
Product No.: 1938217001
Type/Serial No. As per rating label on machine
Engine Displacement: 161 cm³
Rated Engine Power: 2.9 kW / 3600 rpm
Tilling Width: 560 mm

Complies with the following directives:

Machinery Directive 2006/42/EC

The conformity assessment procedure followed was in accordance with
EN 709:1997+A4:20019; EN 709:1997+A4/AC;

Noise Directive 2000/14/EC

Guaranteed Noise Power Level L_{WA}: 93 dB(A) - uncertainty: 2 dB(A) According to 2000/14/EC
Measured Sound Power: 93 dB(A)
Vibration a_{hv}: 13 m/s² - uncertainty K: 2 m/s²

Electromagnetic Compatibility Directive 2014/30/EC

The conformity assessment procedure followed was in accordance with
EN ISO 14982:2009

Notified Body:

TÜV Rheinland LGA Products GmbH

Addresses:

Tillystraße 2, 90431 Nürnberg, Germany

Authorised signatory and technical file holder

Date: 01/07/2019

Signature:

A handwritten signature in black ink, appearing to read "S Belcher", written over a horizontal line.

Name: Mr Simon Belcher

Position: Chairman

Company: Handy Distribution Ltd

Address: Murdock Rd, Swindon, Wiltshire, SN3 5HY.





INSTRUCTION MANUAL

This Service Book is provided with your Webb, to help you look after your purchase to our recommendations and enable you to take advantage of the conditional manufacturer domestic warranty*.

Present this service book to your authorised Webb repair dealer, whenever a service or a warranty appraisal is required.

The booklet is applicable to the following products, in the UK only:

- Ride On Lawn Tractors
- Cylinder Lawnmowers
- Petrol Rotary Lawnmowers
- Petrol Hand Held Range

Please register your machine using the following pages or at www.webbgardenpower.co.uk. By registering your machine, you agree to maintain the machine in accordance with the service schedules specified in this manual and services duly recorded. (Not applicable for Webb electric handheld machines). You may be asked to produce this booklet as proof of servicing in the event of a claim. Proof of purchase should also be kept as a reference.

Ensure you have the following information available from your machine product label. The two examples below can be found on your machine:



1. Model Number

2. Serial & Product Number

1. Users Statement of Warranty

Each new machine is warranted against defective material or assembly of material under normal usage. The warranty applies to the original purchaser, is not transferable and covers faulty parts and the labour involved in replacing and repairing those parts, which are of original manufacture.

2. Period of Warranty - valid from 1 January 2020

Webb (excludes Dynamic, Legacy & Heritage), 2 year conditional warranty from the original date of sale to the first domestic user.

Webb (Dynamic, Legacy & Heritage) 1 year warranty from the original date of sale to the first domestic user.

90 days from the original date of sale to the professional/commercial or for hire user.

Engine warranty as per the engine manufacturer's warranty, which will be supplied with the machine.

90 days from the original date of sale for Replacement Spare Parts

All machines' must be serviced within the first 14 months from the original date of purchase, to qualify for a second year parts & labour warranty, details of the service must be recorded in the service record within this manual.

A reduced warranty period of 90 days applies to those items which are subject to normal wear and tear and in normal use, will need replacement or adjustment.

These items are chargeable after 90 days of ownership.

Filters
Tyres / Wheels
Drive chains and belts
Brake & clutch friction components
Control cable & starter cords
Fluids & lubricants
Spark plugs
Blades (Lawnmowers & Brushcutters)
Cutter bars (Hedgecutters)
Drive & clutch cable surfaces
Nylon Lines (Line Trimmers)
Carburettor cleaning
Bearings
Bushes
Electric cable
Grass collectors

3. Not covered by this warranty

(a) The warranty policy does not cover any depreciation or damages caused by ordinary wear, rusting or corrosion, lack of correct maintenance or operation, misuse, abuse, lack of transportation or accident.

(b) The warranty policy does not cover any costs necessary for the standard periodic maintenance services instructed by the operators manual, or service parts replacement which would include oil, filters, tyres, belts, brake linings, fuses, blades, seals and other service parts unless it can be proven that the item has evidence of faulty manufacture.

(c) The warranty policy will not cover failure or damage caused as a result of parts or accessories being modified without the written approval of GJ Handy & Co Ltd.

(d) The warranty policy will not cover the unit if non-genuine parts have been fitted and as a result damage has occurred to the unit.

(e) The warranty policy is non-transferable and is only applicable to the original purchaser.

4. Disclaimer

(a) This warranty is only a remedy for defect of products. GJ Handy & Co Ltd will never warranty in terms of the merchantability or the fitness for a particular purpose.

(b) No person is authorised to make any warranties, representations or promises, expressed or implied, on behalf of GJ Handy & Co Ltd, or to modify the terms conditions or limitation of this warranty policy in any way.



INSTRUCTION MANUAL

(c) Neither GJ Handy & Co Ltd nor any company affiliated with GJ Handy & Co Ltd shall be liable in any event or manner whatsoever for incidental or consequential damages or injuries, including, but not limited to, loss of crops, loss of profit, out of pocket expenses or profits, rental of substitute equipment or other commercial losses.

5. General

(a) Most warrantable failures show up within the first few weeks of use. These failures are usually straightforward and warranty assessment is relatively easy.

(b) Failures relating to cutter decks and belts need careful investigation, as the cause may not always be straightforward. Look for damage to blades and pulleys especially when the cutter belt or blade boss have snapped or cracked as this could be due to impact damage.

(c) Customers should always refer to the operator/instruction manual when any disputed problem arises, you will find most areas covered within the manual.

Protecting your machine

Maintenance

Regular maintenance of your Webb machine is essential to ensure it operates, safely, efficiently and therefore reducing the environmental impact.

It is the owner's responsibility to ensure that their Webb machine is maintained at specific intervals. Any approved Webb service dealer can undertake a service, which are specialised in our products and will be aware of your particular machine and any technical updates which will save valuable time & money.

If you are using your machine in dry, dusty or high temperatures, you will need to service the machine more regularly.

Fuel (if applicable)

Due to ongoing efforts by fuel companies to reduce emissions, unleaded petrol will oxidize & deteriorate in storage overtime, leaving residue from detergent components.

Fuel deterioration problems may occur when petrol is stored for over 30 days. If you are planning to store fuel for over 30 days, we recommend you add Handy Parts Sure-Start fuel stabilizer to fresh fuel after purchasing. Sure-Start cannot reconstitute stale fuel.

Storage

When storing your machine for an extended period, we do recommend that you follow the instructions of engine instruction manual.

Always store the fuel in a clean, approved and sealed container. If the container is steel, ensure it is not corroded. If the container is not filled to its recommended capacity, air can accelerate fuel deterioration.

Always store fuel away from direct sunlight, in a dark, cool environment.

Your servicing Webb approved dealer will stamp & date the below relevant sections, when the correct service actions have been completed.
PLEASE ENSURE THE SERVICE BOOK IS AVAILABLE FOR THE DEALER, DURING SERVICE WORK.

1st Service

This must be stamped by an approved service dealer to qualify for a free second year warranty.
(Excluding the Webb Electric Handheld machines)

12 Months

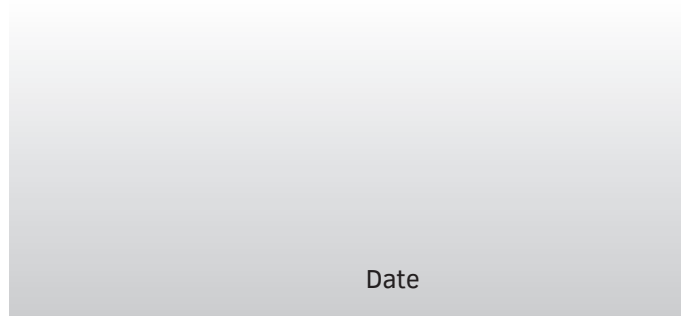

Date

24 Months

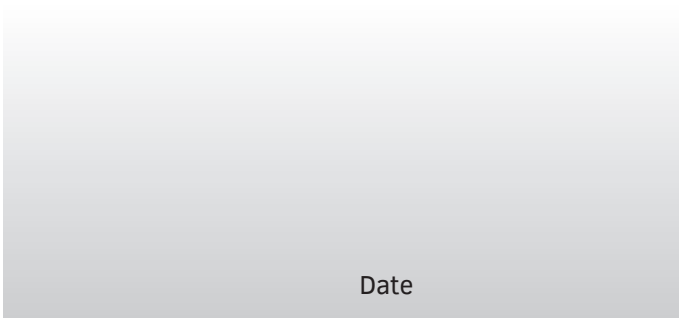

Date

36 Months

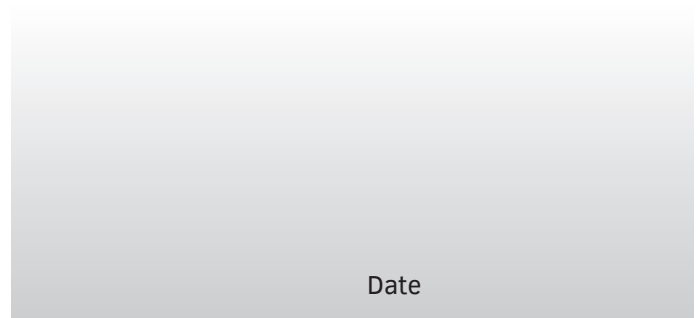

Date



INSTRUCTION MANUAL

48 Months

Date

60 Months

Date

72 Months

Date

84 Months

Date

96 Months

Date

108 Months

Date

120 Months

Date

132 Months

Date

Product Information (* Compulsory)

If you have registered online, this form is not necessary.
PLEASE POST THIS COPY TO THE ADDRESS OVERLEAF

*Model No:	
*Product No:	
*Serial No:	
*Date of Purchase:	

Personal Information (* Compulsory)

*Title		*Forename		*Surname	
*House Number		*House Name			
*Address 1					
*Address 2					
*Town					
*County					
*Postcode					
Home Tel			Mobile Tel		
Email					

Age	18 to 25		26 to 35		36 to 45		46 to 60		61 to 80		81 & over
*Usage	Domestic Use			Commercial/Professional/Hire Use							

*Dealer Stamp (if available)



*Selling Retailer (If dealer stamp not available)

*Dealer Name	
*Dealer Address	
*Date of Purchase	

Webb Lawnmowers privacy commitment to machine owners.

The information supplied, helps us to improve the products & services we provide, including information that we believe is relevant to your and/or your machine. We value your trust by giving us this information about yourself and we are committed to protecting your privacy.

Webb, its associated companies, authorised dealers or third parties working on our behalf may wish to contact you regarding **PRODUCT RECALLS** specific to your machine. Please advise how you wish to be contacted for this specific reason only:

Post Telephone Email

From time to time Webb, its associated companies, authorised dealers or third parties working on our behalf may wish to contact you regarding our products, services, offers or just opinions, which may be used for marketing, research or analysis purposes.

If you wish to be contacted by any of the following methods, please tick the relevant boxes:

Post Telephone Email

You may give Webb Lawnmowers notice in writing at any time that you no longer wish to receive direct marketing communications

Webb Lawnmowers
Murdock Road
Dorcan
Swindon
Wiltshire
SN3 5HY