

Comet Combination Unit

INSTALLATION

&

TECHNICAL MANUAL

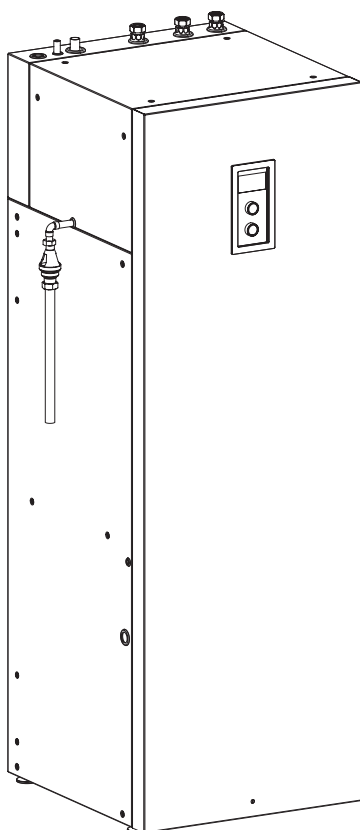

ehc

the electric heating company

Unit 40 block 5 Third Road
Blantyre Glasgow
G72 0UP

Tel: 01698 820533 Fax: 01698 825697
email: info@electric-heatingcompany.co.uk

Contents Page

| | |
|---|-----------|
| 1. Introduction | 4 |
| 2. Contents | 4 |
| 3. Safety | 5 |
| 4. Installation: Dimensions | 6 |
| 5. Installation: General | 7 |
| 6. Hydraulic schematic | 10 |
| 7. Installation: Plumbing | 11 |
| 8. Installation: discharge arrangement | 13 |
| 9. Electrical Connection | 15 |
| 10. Connection of external appliances & Controls | 16 |
| 11. Electrical Schematic | 17 |
| 12. Commissioning | 18 |
| 13. Control panel - default settings | 19 |
| 13. Control panel- optional settings with OS | 24 |
| 14. Annual Servicing | 29 |
| 15. Guarantee | 30 |
| 16. Troubleshooting | 30 |
| 17. Technical data | 31 |
| 18. Benchmark Service Record | 32 |

This Document MUST be left in the possession of the house holder on completion of installation of this product.

1. Introduction

Thank you for specifying the Comet Combination Unit (hereafter referred to as the Comet Combi) from The Electric Heating Company.

The Comet Combi is an electrically heated direct acting self modulating boiler that is designed for domestic heating purposes, The Comet Combi consists of an electric heating boiler and an indirect unvented hot water cylinder with the necessary safety devices. The Comet Combi Boiler also has an inbuilt programmer that allows you to set your heating and hot water times to suit your life style.

**This appliance is not intended for use by persons (including children with reduced physical, sensory or mental capabilities, or lack of experience and knowledge) unless they have been given supervision or instruction concerning use of the appliance by the person responsible for their safety.
Children should be supervised to ensure they do not play with the appliance.**

- The Electric Heating Company reserve the right to make minor changes to the specification or design when necessary.
- All boilers come with a 24 month warranty that covers all defects originating from faulty materials and workmanship in the manufacture of the boilers.
- The warranty covers the replacement of any faulty parts and labour costs.
- The warranty will not cover any damage to the boiler from poor or incorrect installation work.
- The warranty will not cover any call out charges that have not been authorised by the Electric Heating Company Ltd.
- The warranty will not cover water leaks into the boiler. All plumbing joints must be checked.
- The warranty card must be completed and sent back to The Electric Heating Company as soon as possible for registration.
- An internal Magnetic Filter is fitted to the Boiler and it must be cleaned at least annually.
- Failure to clean the Magnetic Filter may result in boiler shut-down, this will not be covered under warranty.
- Take care when handling the boiler not to cause any damage to the unit.
- The boiler must be stored in a dry place.
- Care must be taken when installing the boiler to make sure the floor area will take the boilers full weight when full.
- Minimum clearances must be adhered to.

2. Contents

- Comet Combi Boiler
- Monoblock Control Set Valve
- Room Sensor / Room Stat
- External Sensor
- Tundish
- Installation Manual
- Filling Loop

Optional Extras

- EHC Shower Flow Sensor (Part Code ESFS15C)
- Backup Immersion Heater (Part Code CB150)
- Solar PV Immersion Heater (Part Code CB150)

3. Safety

Please read and understand these instructions before installing the Comet Combi. Following the installation and commissioning instructions of the Comet Combi the system should be explained to the customer and all instructions left with them for future reference.



- The Comet Combi must be installed in accordance with the manufacturer's instructions and all relevant regulations in force at the time of installation.
- The Comet Combi's Domestic Hot Water Cylinder is of the UNVENTED type. Its installation is subject to Building Regulation G3 (England and Wales), Technical Standards for (Scotland) or Building Regulation (Northern Ireland). The Installation must be carried out by a competent person qualified to do so.
- The Comet combi must be installed into a sealed (pressurised) primary system. Following installation or the primary system the unit should be flushed in accordance with BS7593 and appropriate cleaner & inhibitor added to the system.
- The Comet Combi's hot water cylinder is indirectly heated by the primary heat exchanger located within the unit.
- Please note a load check should be taken into consideration when installing high output electrical appliances.
- The use of an Off-Peak tariff that provides at least three off peak electricity periods, such as Economy 10 is recommended. Where possible the central heating and hot water should be programmed to coincide with the Off Peak periods available. For more information on tariffs please contact the Electric Heating Company.



This appliance must be fitted in accordance with the following instructions.

The Local Building Regulations

The Building Regulations

The Building Standards, (Scotland-consolidated) Regulations. Local water bylaws. British Standards-code of practice

4. Installation: Dimensions

Note:

Please take care to leave enough space at the front of the boiler for routine maintenance!

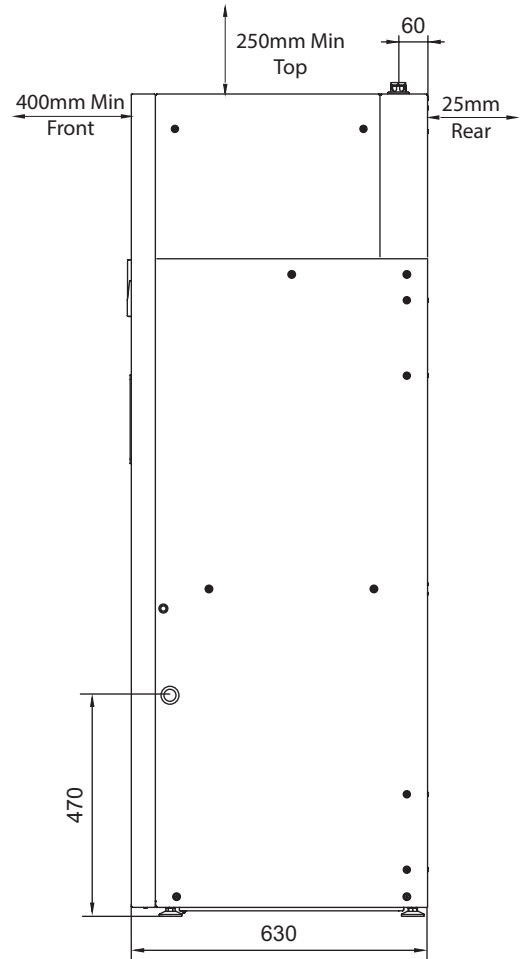
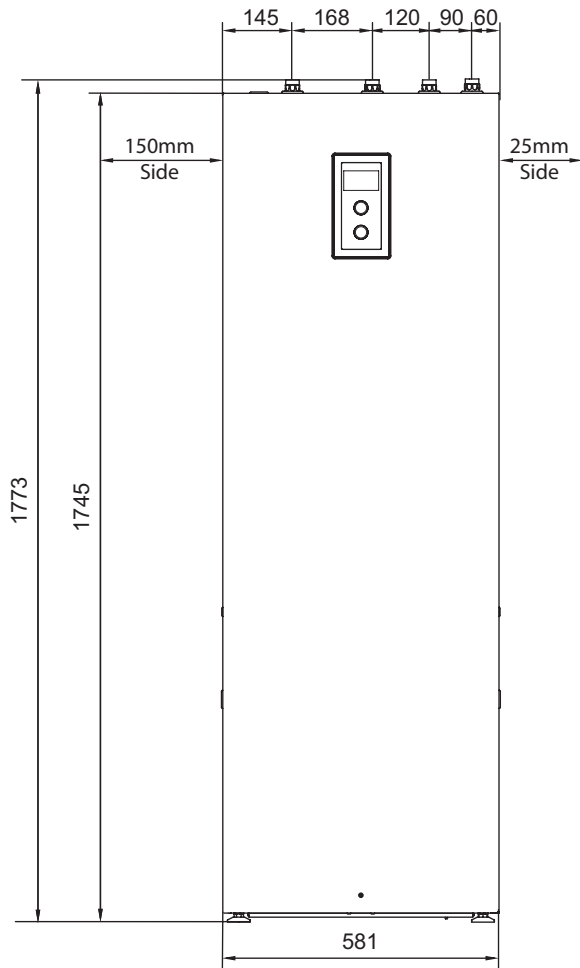

- Remove the boiler packaging checking the contents are correct.
- Take care when lifting the boiler not to cause damage to the outer casing.
- Due to the weight of the product the use of a handling device will be required.
- The boiler should be handled by minimum two persons with handling device.
- Lift the boiler by the internal frame only, do not lift by pipes.
- Stooping should be avoided and protective clothing worn.
- Packaging is recyclable and should be disposed of appropriately.

5. Installation: General

1. General

The boiler must be installed by a professional plumber or heating engineer and must be connected to the public low voltage network by a competent person. For systems that require a three phase electrical supply we strongly recommend this is installed by a certified Electrician.

The Electric Heating Company will not be held responsible for faulty installations which are performed by unqualified tradespeople.

2. Pipe Connections

All Comet Combi Electric Boilers have 22mm Compression pipe connections that are clearly marked. Please note that the boilers are supplied with blank plugs for transit purposes that must be removed before fitting.

Mains Inlet, Hot Outlet, Flow & Return connections are clearly marked on the external case, under no circumstances should these connections be reversed.

If hot capillary joints are to be used, these joints must be made before connections to the boiler are done.

3. Case Removal

Loosen the outer screw at the bottom of the boiler and pull the front cover up & outwards taking care to remove internal earth connections. Earth connections must be re-connected before the boiler case is re-installed.

4. Isolation Valves

We recommend that full bore isolation valves are fitted on the Flow, Return & Main Water Supply Pipework. Such valves must be full bore and not "ball valves". The installation of ball valves in the flow and return pipework will reduce the recommended flow rate through the boiler.

5. Auto air vents

An auto air vent is integral within the boiler, however additional air vents will be required at the highest point of the heating system pipework.

6. Boiler sizing

Calculate the space heating requirements in accordance with BS EN 12831 and BS EN 1433. An additional allowance of 3kW (10,239 Btu's) should be made to the 'space heating' calculation.

7. Insulation

Where practical, and if at all possible, we recommend that all pipework be insulated, in particular the primary pipework within a boiler cupboard. This is to reduce heat loss and reduce high cupboard temperatures from exposed pipework.

8. System Design

Allowance should be made for a bypass radiator to be installed within the heating circuit and locked open. This will be located in

the room that has the room thermostat installed. To comply with building regulations.

9. Water Connections

Provisions must be made for the replacement of water lost from the heating system (sealed systems). Reference should be made to BS EN 14336 for the method of filling and make up of water. There must be no direct connection between the boilers central heating system and the main water supply. When mains water is required to fill the system directly, all local water bylaws must be observed, and any connection made must be disconnected after use.

10. Flushing

The system **must be flushed** to within 10% of mains water PPM to ensure that no debris is trapped in the system as this may result in boiler failure. Where existing radiators and pipe-work are utilized a power flush must be carried out to remove debris. For further guidance please see section - Flushing & System Protection.

11. System pressures

All boilers are tested to 4.0 bar. The normal working pressure of the boiler should be set to approx 1.0 / 1.5 bar. All sealed systems should comply with the relevant building regulation and standards, including BS EN 13831 – Specification for Expansion Vessels.

Please note:

In order to protect the boiler, it is imperative that the pre-installed magnetic filter is removed and cleaned at least annually. Failure to carry out this action will increase contamination of the boiler by system residue.

12. System types

The Comet Combi range of boilers can be used in various system designs. Please refer to The Electric Heating Company for more details on our Comet Combi Boiler for under floor heating.

We recommend the use of thermostatic radiator valves on all radiators except in the room that has the wall thermostat fitted. This radiator should be fitted with lock shield valves and left in the fully open position.

Systems should be designed to meet the current building regulations in force at the current time.

13. Structural Strength Of Installation Location

This appliance is floor standing only and considerations must be made with regards to suitable floor strength where this appliance is to be sited. It is recommended that a suitably qualified professional is consulted to ensure the floor structure can support the gross weight of this appliance.

5. Installation; General

The following steps will assist in removing the casing for installation & maintenance purposes.

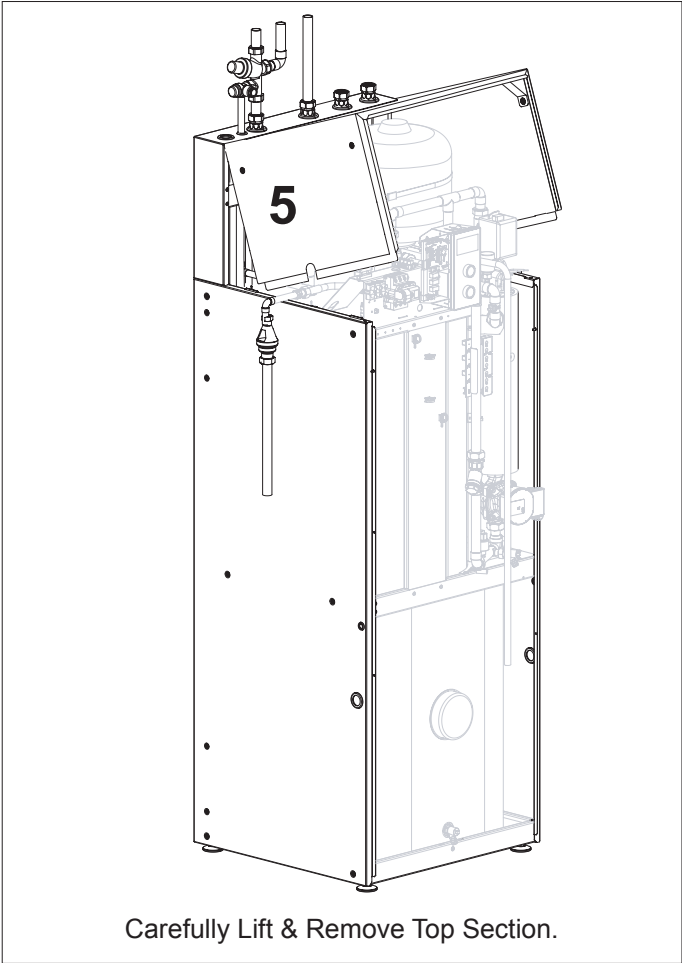
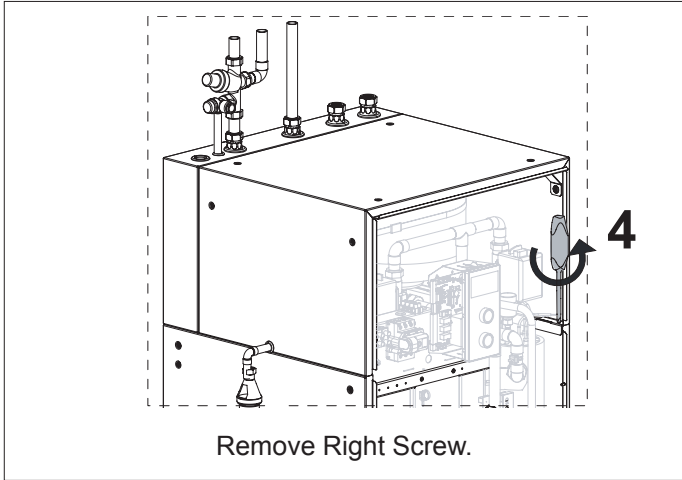
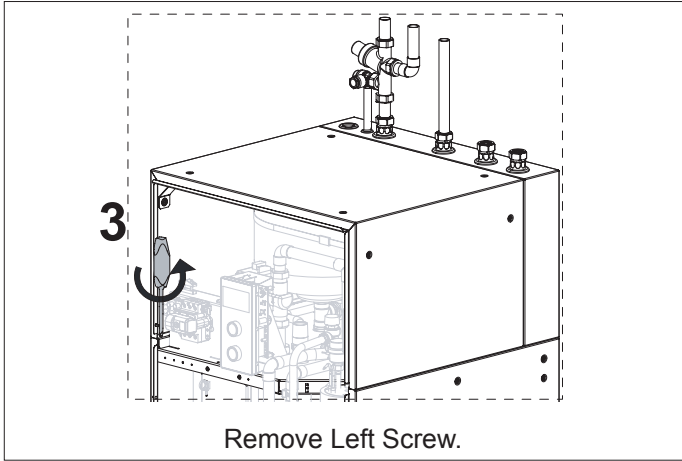
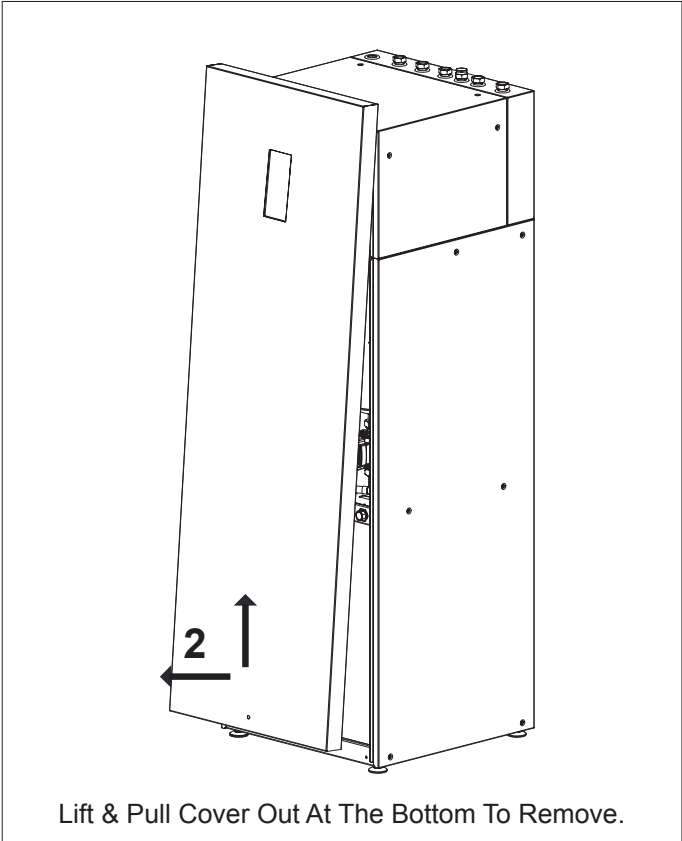
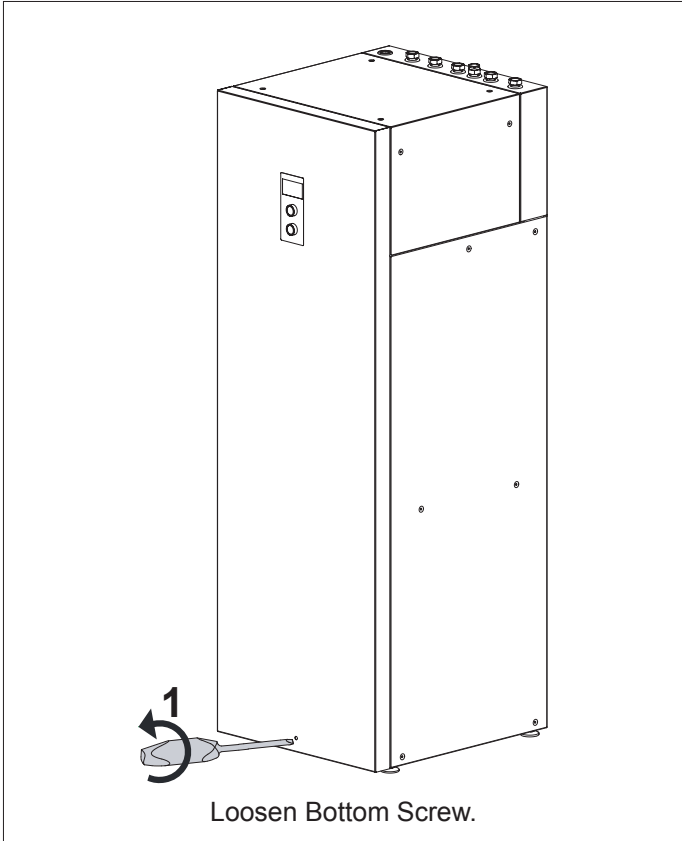

5. Installation; General

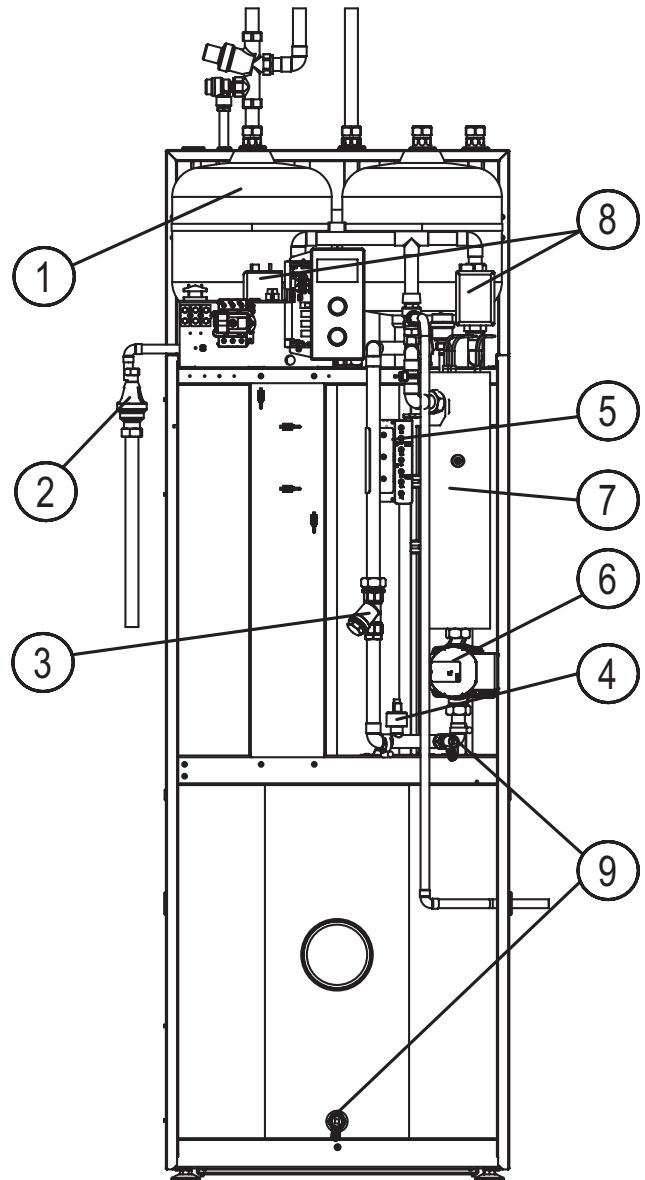
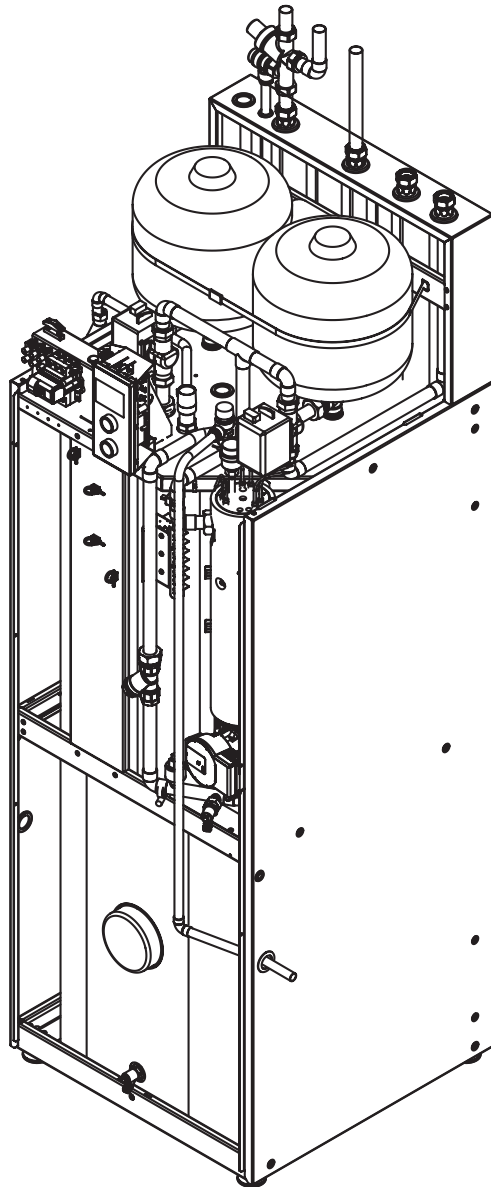

- 1 - Expansion vessel
- 2 - Tundish
- 3 - Magnetic Filter
- 4 - Pressure Sensor
- 5 - Power Board
- 6 - Pump
- 7 - Heat Exchanger including AAV
- 8 - Zone valves
- 9 - Drain valve

6. Hydraulic schematic

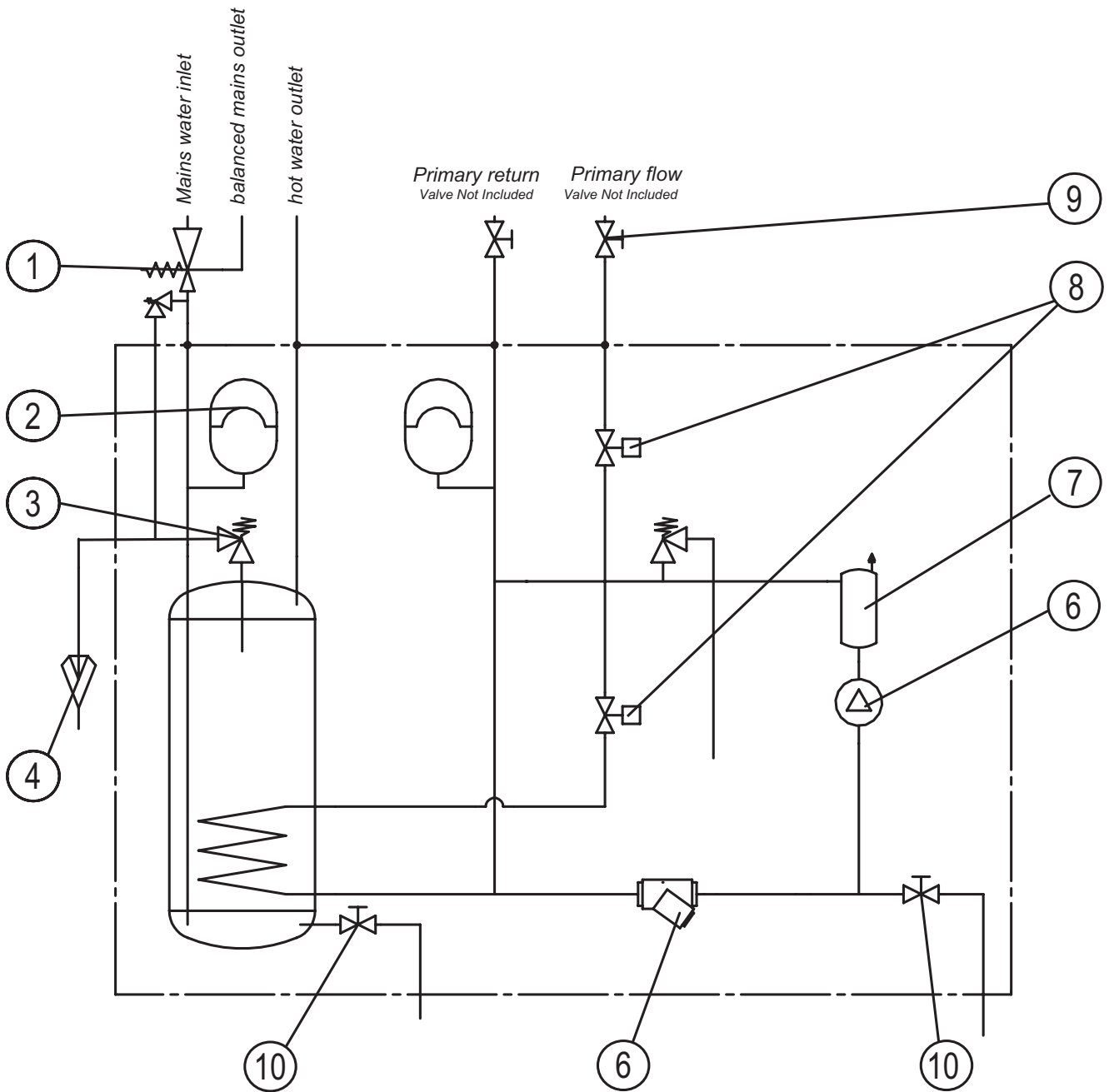

- 1 - Combination Valve with PRV
- 2 - Expansion vessel
- 3 - T&P Relief valve
- 4 - Tundish
- 5 - Magnetic Filter
- 6 - Pump
- 7 - Heat Exchanger including AAV
- 8 - Zone valves
- 9 - Isolating valves (Not included)
- 10 - Drain Valve

7. Installation: Plumbing

Water supply requirements

The Comet Combi operates at 3 bar (controlled by the inlet set) and is capable of delivering over 50 litres per minute. The high quality inlet control set has been designed to make the most of the flow rates available, however the performance of the system is only as good as the mains water supply to the unit. The maximum possible water demand should be assessed by taking into consideration that both hot and cold services are supplied simultaneously from the mains. The water supply should be checked to ensure it can meet these requirements. If necessary consult the local water company regarding the likely pressure and flow rate availability.

If measuring the water pressure, please note that a high static (no flow) mains pressure is no guarantee of a high flow rate. In a domestic installation 1.5 bar and 25 l/m should be regarded as the minimum. The maximum recommended mains pressure for the inlet control set is 12 bar. Consideration should be given to upgrading existing ½" (15mm) cold mains pipework to a larger size if the recommended minimum pressure / flowrate is not being achieved.

Cold mains pipework

1. Run the cold water mains pipework to the location of the Comet Combi. Take care not to run cold pipes close to hot pipework as this will cause thermal transfer.
2. Install an isolating valve (not supplied) before the combination valve. A 22mm BS1010 stopcock can typically be used, however a 22mm 1/4 turn full bore valve is preferable as it is less likely to restrict the flow. Do not use "screwdriver slot" or similar valves.
3. Allow space for a 22mm x 22mm x 15mm tee between the combination valve and the boiler heating return connection for the system filling loop. This must be disconnected after the system has been commissioned.

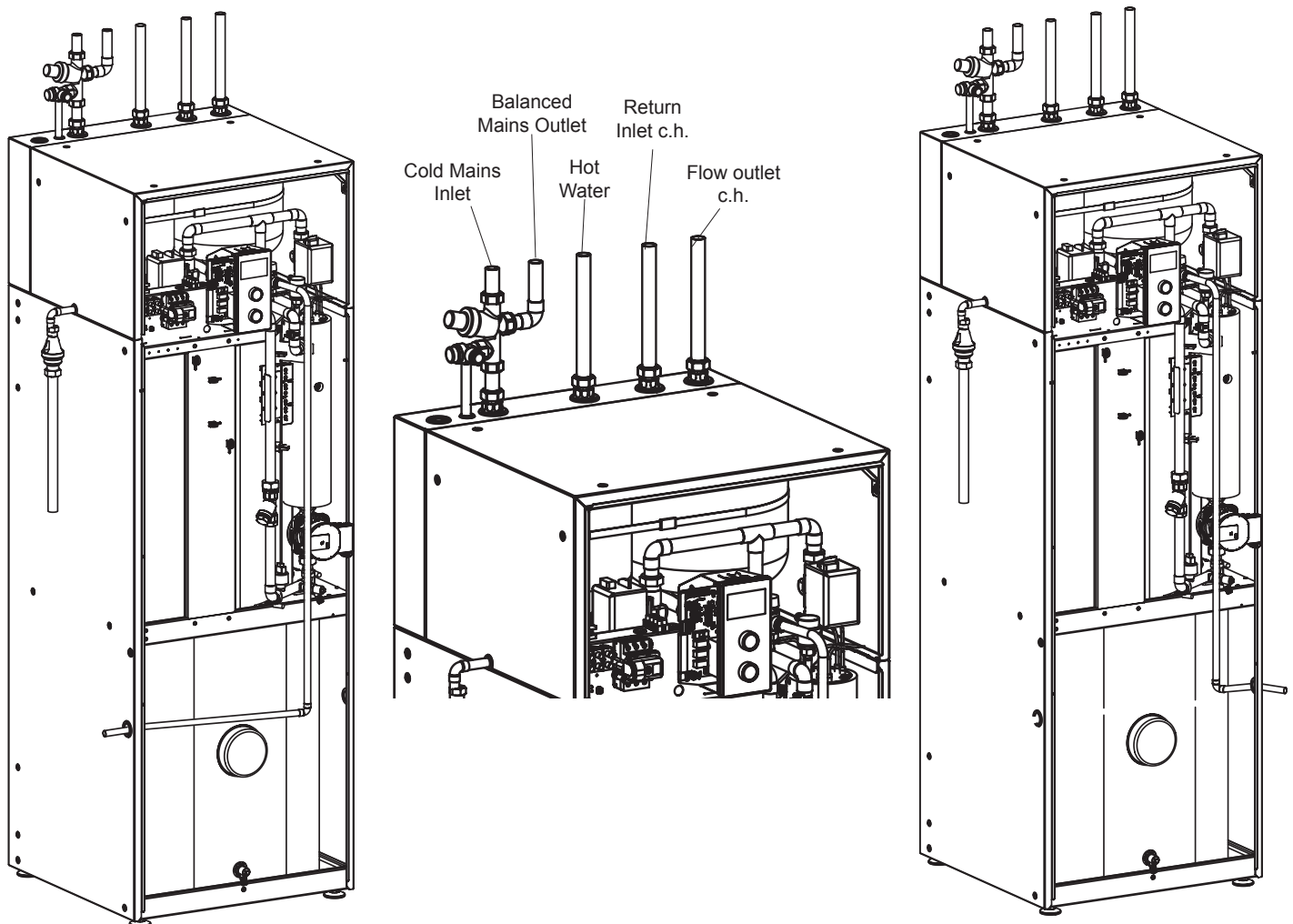

7. Installation: Plumbing

Balanced cold connection



Do not use monobloc mixer taps or showers if the balanced cold connection is not used. Outlets of this type can back-pressurise the unit and result in discharge.

A 22mm balanced cold mains outlet can be found on the control set supplied, (see diagram below)

Use the balanced cold mains outlet from the inlet control set (as shown in the illustration) to feed all mixer taps / showers, instead of connecting them direct to the cold main supply. If this is not possible then a pressure reducing valve can be installed immediately after the incoming cold mains stopcock (typically under the kitchen sink).

All outlets in the house will be set to 3 bar and thus automatically balancing the system. The expansion relief valve section must still be mounted just above the boiler (see diagram below).

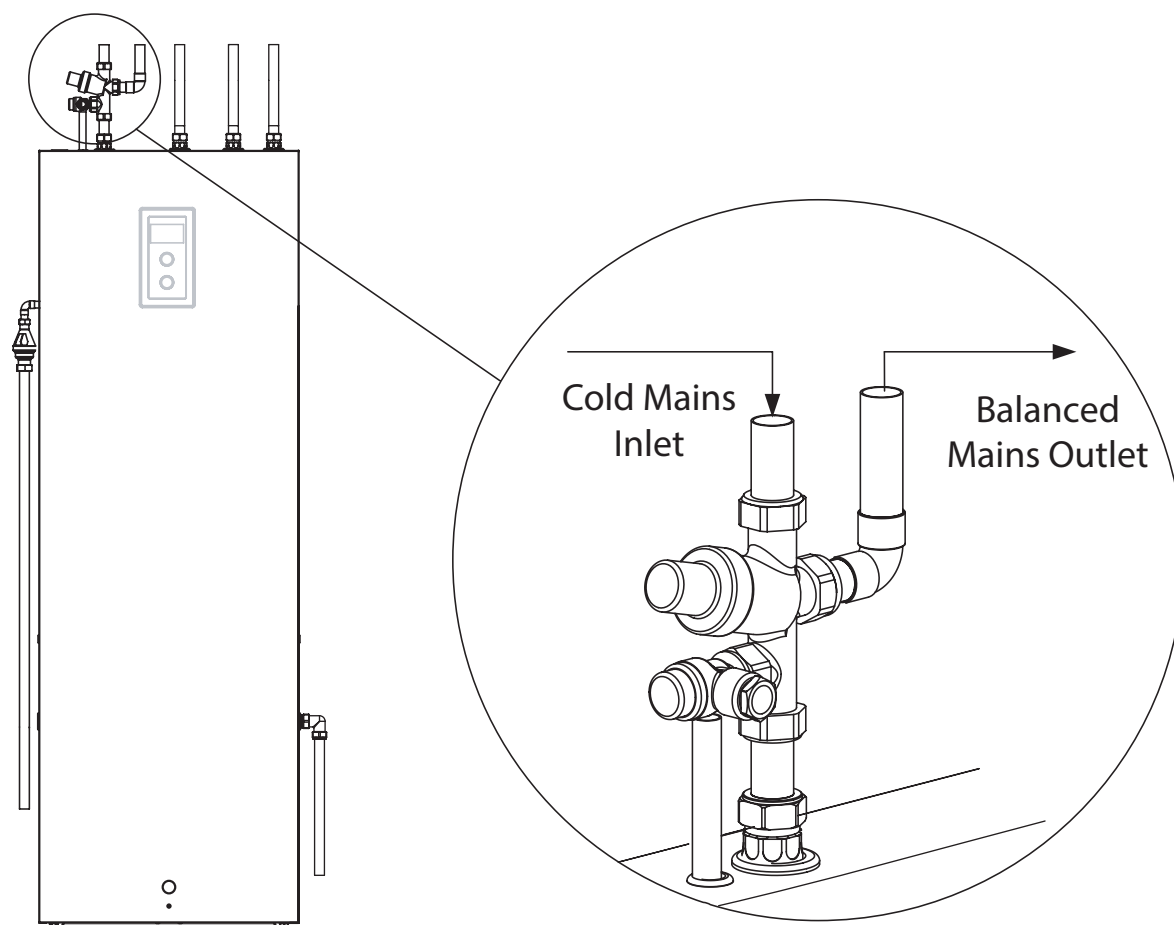

Hot Water Pipework

Ensure the first part of the hot water pipework is run in 22mm pipe. This can be reduced to 15mm depending on the type of taps outlets used etc. Your aim should be to reduce the volume of the hot draw off pipework to a practical minimum so that the time taken for the hot water is as quick as possible to the point of use.

Hard Water Areas

If the unit is installed in a hard water area that exceeds 200mg/L a water softener must be used. This device will be connected to the mains water supply within the property and must be of the type that can be connected to unvented hot water systems. Consideration should also be made with regards to the chosen stored water temperature as higher temperatures will increase the formation of scale within this unit.

8. Installation: discharge arrangement

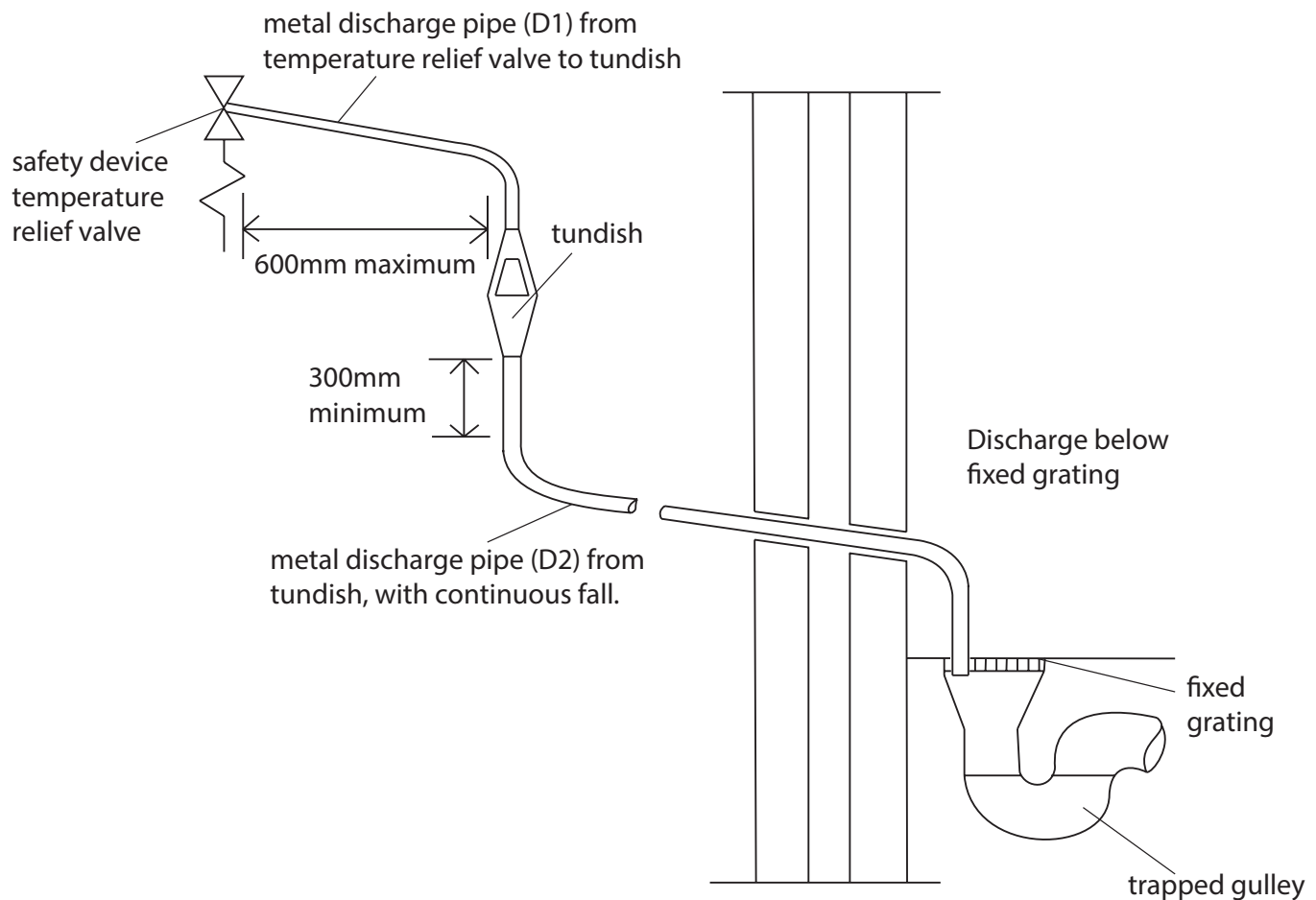

The above diagram is of a typical discharge pipe arrangement. (extract from Building Regulation G3)

Note: The discharge will consist of scalding water and steam. Asphalt, roofing felt and nonmetallic rainwater goods may be damaged by such discharges.

Note: It is not acceptable to discharge straight into a soil pipe. Position the inlet control group so that the discharge from both the two safety valves can be joined together via a 15mm end feed Tee. Connect the Tundish and route the discharge pipe.

The discharge pipework must be routed in accordance with Part G3 of schedule 1 of the Building Regulations.

The information that follows is not exhaustive and if you are in doubt you should seek advice.

The two safety valves will only discharge water under fault conditions. When operating normally water will not be discharged. The tundish should be vertical, located in the same space as the unvented hot water storage system and be fitted as close as possible and within 600mm of the safety device e.g. the temperature relief valve. The discharge pipe (D2) from the tundish should terminate in a safe place where there is no risk to persons in the vicinity of the discharge, be of metal and:

- A) Be at least one pipe size larger than the nominal outlet size of the safety device unless its total equivalent hydraulic resistance exceeds that of a straight pipe 9m long i.e. discharge pipes between 9m and 18m equivalent resistance length should be at least two sizes larger than the nominal outlet size of the safety device, between 18 and 27m at least 3 sizes larger, and so on. Bends must be taken into account in calculating the flow resistance. Refer to diagram 1, Table 1 and the worked example. An alternative approach for sizing discharge pipes would be to follow BS6700 Specification for design installation, testing and maintenance of services supplying water for domestic use within buildings and their curtilages.
- B) Have a vertical section of pipe at least 300mm long, below the tundish before any elbows or bends in the pipework.
- C) Be installed with a continuous fall.
- D) It is preferable for the discharge to be visible at both the tundish and the final point of discharge but where this is not possible or practically difficult there should be clear visibility at one or other of these locations. Examples of acceptable discharge arrangements are:



8. Installation: discharge arrangement

1. Ideally below the fixed grating and above the water seal in a trapped gulley.
2. Downward discharges at a low level; i.e. up to 100mm above external surfaces such as car parks, hard standings, grassed areas etc. are acceptable providing that where children play or otherwise come into contact with discharges, a wire cage or similar guard is positioned to prevent contact whilst maintaining visibility.
3. Discharges at a high level; e.g. in to metal hopper and metal down pipe with the end of the discharge pipe clearly visible (tundish visible or not) or onto a roof capable of withstanding high temperature discharges of water and 3m from any plastic guttering systems that would collect such discharges (tundish available).
4. Where a single pipe serves a number of discharges, such as in blocks of flats, the number served should be limited to not more than 6 systems so that any installation can be traced reasonably easily. The single common discharge pipe should be at least one pipe size larger than the largest individual discharge pipe to be connected. If unvented hot water storage systems are installed where discharges from safety devices may not be apparent i.e. in dwellings occupied by blind, infirm or disabled people, consideration should be given to the installation of an electronically operated device to warn when discharge takes place.

Worked example

The example below is for G1/2 temperature relief valve with a discharge pipe (D2) having four elbows and length of 7m from the tundish to the point of discharge.

From Table 1:

Maximum resistance allowed for a straight length of 22mm copper discharge pipe (D2) from a G1/2 temperature relief valve is: 9.0m

Subtract the resistance for 4 x 22mm elbows at 0.8m each = 3.2m

Therefore the maximum permitted length equates to: 5.8m

5.8m is less than the actual length of 7m therefore calculate the next largest size. Maximum resistance allowed for a straight length of 28mm pipe (D2) from a G1/2 temperature relief valve equates to: 14m

As the actual length is 7m, a 28mm (D2) copper pipe will be satisfactory.

Table 1

Sizing of copper discharge pipe 'D2' for a temperature relief valve with a G1/2 outlet size (as supplied).

| Size of discharge pipework | Maximum length of straight pipe (no bends or elbows) | Deduct the figure below from the maximum length for each bend or elbow in the discharge pipe |
|----------------------------|--|--|
| 22mm | Up to 9m | 0.8m |
| 28mm | Up to 18m | 1m |
| 35mm | Up to 27m | 1.4m |



Note:

- The tundish must be installed in such away that it is visible to the occupants, and positioned away from any electrical controls or connections.
- Cylinder Relief valve connections should not be used for any other purpose than intended.
- No valve should be fitted between the expansion relief valve and the storage cylinder.

9. Electrical Connection

ALL WIRING MUST BE CARRIED OUT IN ACCORDANCE WITH CURRENT IEE BS7671 WIRING REGULATIONS.

ALL ELECTRICAL CONNECTIONS MUST BE MADE BY A QUALIFIED ELECTRICIAN.

Load check must be taken into consideration when installing high power boilers. This will be carried out by a qualified electrician. There may be an additional requirement to upgrade the incoming main fuse supplying the property if other high power devices are used within the property. E.g. Electric Showers. If an electric shower is present we recommend that a Shower Sensor is installed within the system. This will cause an interrupt to the boilers control signal when the shower is in use. The sensor will disable the boiler protecting the electrical system from overload. All boilers must be protected at the meter position with a 30mA double pole RCD with a minimum of 3mm contact separation accompanied by a suitably rated MCB. If the boiler is not fitted local to the meter position then an additional isolation switch must be fitted local to the boiler for each supply. If the property is prone to lightning strikes or power cuts it is recommended to install a suitable surge protection device to the boiler supply. This will reduce the risk of damage to the boiler electronics during these events.

THIS APPLIANCE MUST BE EARTHED.

All pipe-work must be earthed in accordance with the IEE BS7671 Wiring Regulations.

After completion of all electrical works, an electrical safety check should be carried out i.e. short circuit, earth continuity, resistance to earth and polarity check, and all relevant Test Certificates completed and issued to the customer.

Never open the front cover of the boiler until all power supplies to the boiler have been disconnected.

ELECTRICAL CONNECTIONS

The electrical supply cables can be routed into the boiler from the top left hand side of the unit. Cable grommets are supplied and fitted to the boiler's cable entry point.

All cables should be secured to meet current regulations. The boiler connections are clearly marked inside the boiler L- Live, N - Neutral, E - Earth.

The supply is a permanent Feed connection to the boiler from the mains supply and should never be isolated unless for maintenance purposes.

The Boiler circuit RCD should be independent of all other domestic circuits. The boiler supply cable should be calculated by the means of a cable calculation in accordance with BS7671 by a suitably qualified electrician.

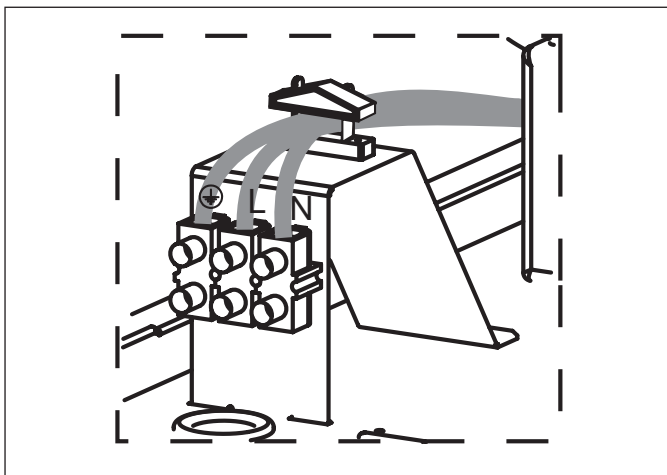

BOILER PROTECTION

The recommended protection for hard wired boilers are as follows:

| Model No | Boiler size | Protection (per phase) |
|--------------------|---------------|------------------------|
| Comet Combi 14.4kW | 14.4kW BOILER | 80 AMP Protection |
| Comet Combi 12kW | 12kW BOILER | 63 AMP Protection |
| Comet Combi 9kW | 9kW BOILER | 50 AMP Protection |

EXTERNAL CONTROLS.

We recommend using EHC controls with our boilers. Connect the RF receiver supplied with the boiler as shown below. The receiver and room thermostat is preconfigured

The use of EHC controls ensures that boiler interlock is provided as the use of TRV's alone will not provide boiler interlock.

We recommend the use of TRV's, however they must not be used in the room that has the room thermostat fitted.

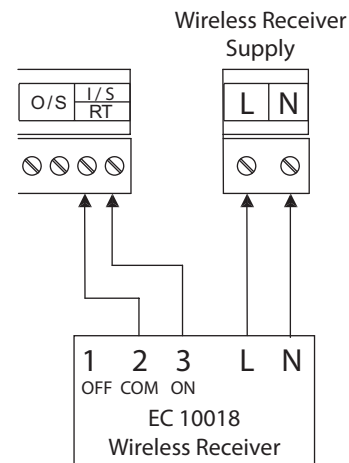

BACK UP IMMERSION HEATER

The Comet Combi has a connection that allows you to install a back up immersion heater if required. It is recommended that this is connected via a local 16A double pole isolation switch and connected to the consumer unit using the correct size cable & 16A MCB

10. Connection of external appliances & Controls

FACTORY CONNECTIONS

ZoneValve (SHW & SCH Volt Free Inputs)

When the Volt Free contacts are open circuit the boiler will automatically stop heating the system.

These connections are factory fitted, under **NO** circumstances should any voltage be connected to these terminals as this will result in damage to the boilers control electronics.

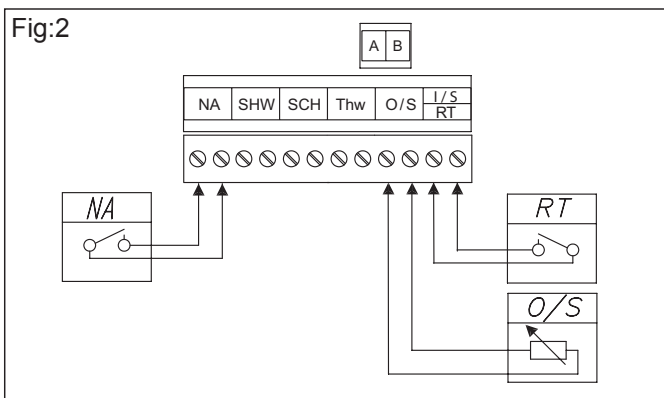
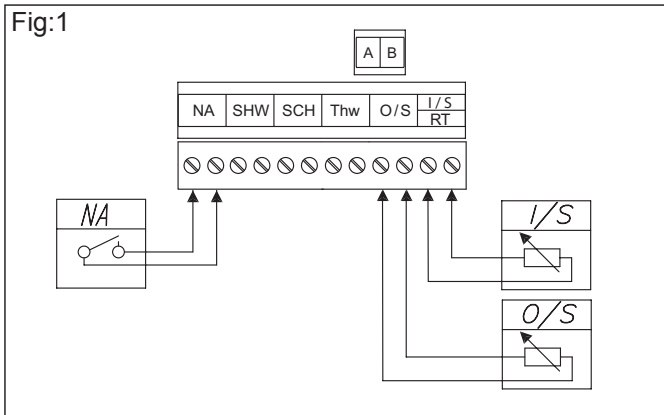

Master Appliance Control (NA)

The NA Connection is used when you have another high current device installed within the property. i.e. Electric Shower or Water Heater.

The shower sensor would be connected to the Main Water supply feeding the shower, the switch wires from the flow sensor will then be connected to the **NA** connections shown in Fig:1.

When the shower is in use the flow sensor will create an open circuit on the NA connections. This will switch the boiler OFF when the shower is in use protecting the power supply within the property.

Temperature sensors

The temperature sensor's cable should be kept as short as possible. Do not run or twist the sensor cable alongside power lines or other wiring.

To manually adjust the default CH temperature go to: SETTINGS > BOILER TEMPERATURE [°C] and select your appropriate value. The temperature of the CH installation can be automatically adjusted when the weather compensation is activated. This can be achieved by activating outside sensor - O/S (see graph 1 and 2) which activates weather compensation. To activate weather compensation go to: CONFIGURATION - CENTRAL HEATING- REGULATION - WEATHER COMP.

Install the outside temperature sensor (O/S) in the shade, on the north or northwestern facade of the building, away from windows and ventilators.

WEATHER COMP – boiler's controller is responsible for adjusting temperature in CH installation in accordance with external (outside) temperature. When the temperature outside the facility is low, heat demand within the facility is higher, whereas while the temperature outside is high, analogically, there's no need to maintain high temperature within the installation. The correlation between outside temperature and heating installation's temperature can be presented in a graphical form of so called heating curve. The diagram below presents a compilation of heating curves for the set point of room temperature equal 22°C. Depending on the facility characteristics, climate zone, and the type of heating installation one must select appropriate heating curve (WEATHER COMP.) Heating curve no 14 (without the offset) is set as a default parameter. If the heating curve needs to be changed, the OFFSET parameter has to be adjusted accordingly. The graph below presents a heating curve no 14 with the offset (-10°C and 10°C).

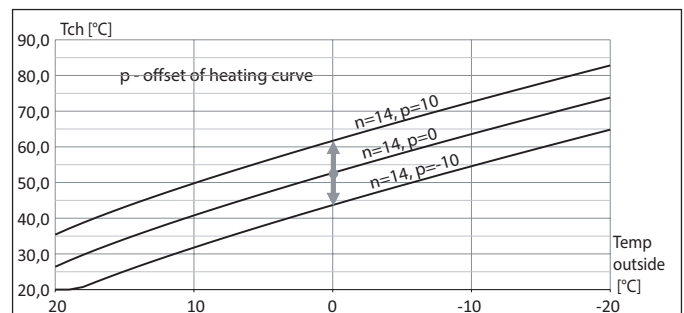
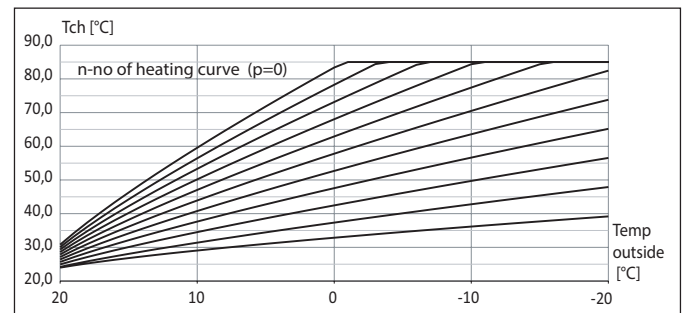

Boiler's operation is dependent on room's temperature. Room thermostat (RT) or NTC stat (I/S) have to be installed in the representative room (such as a living room) away from radiators, windows, doors, or vents.

- RT activated: the boiler operates according to the time frames set in the daily/weekly programs; temperature in the room can only be adjusted manually by using the wireless thermostat
- I/S activated: the boiler operates according to the time frames set in the daily/weekly programs and in accordance with 3 optional temperature settings (selected in the daily programs): COMFORT, COMOFRT +, COMFROT –

RT is set as a default sensor. In order to change it to NTC stat (I/S) go to: CONFIGURATION>ROOM TEMP>TEMP SENSOR>I/S

Please note, that the sensors have to be physically connected to the cable entry points - this can only be done by an authorized person

12. Commissioning

IMPORTANT:

TURN ON THE ELECTRICAL POWER SUPPLY TO THE BOILER. MAKE SURE THAT THE PROGRAMMER IS NOT CALLING FOR HEAT AT THIS STAGE!

FILLING THE HOT WATER CIRCUIT.

1. Check the pressure in the potable vessel is set to 3 Bar
2. Check that all plumbing connections are tight
3. Open the furthest away tap outlet

Note: Make sure that the filling loop is closed at this stage!

5. Turn on the mains water supply to the unit
6. It will take a few minutes to fill the cylinder, once the water comes through the tap outlet let it run
7. Open the other hot water outlets and purge all air out of the system
8. Once fully purged close all the outlets and further check for leaks

FILLING THE PRIMARY HEATING CIRCUIT. THE PRIMARY CIRCUIT MUST BE FLUSHED IN ACCORDANCE TO BS 7593

1. Connect the primary filling loop and tighten.
2. Make sure that all primary connections are tight before filling.
3. Open the filling loop and allow the system to start filling.
4. Turn the control dial to Service/Configuration, (Push to Select), Now turn and select Preview of Parameters, (Push to select), Scroll down to Pressure/Bar.
5. Fill the system to 2 bar, then start to purge the radiators until all the air is out the system.
6. This will have to be repeated several times to fully purge the system re-filling as you go.

System protection:

Failure to protect the system will invalidate the manufacturer's warranty.

1. Fill the system with cold mains water to the recommended pressure 1.5 bar and check for leaks, then drain the system thoroughly making sure all drain cocks are fully open and that the system is completely drained.
2. Add Fernox F3 cleaner to the system at the furthest point from the boiler, this is to allow the substance to fully dilute throughout the system. If you are unsure of the correct dose rate, contact

Fernox on 03301007750 for advice.

3. Re-fill the system and circulate the F3 cleaner prior to the boiler being fired up. Commission the system in the normal way. The cleansing agent must be in the system for a minimum 1 hour with the system running at normal operating temperature. A longer period of time would be more beneficial to the cleansing process especially if excess flux was used or is an old system. F3 cleaner can be left in the system for up to a maximum of one week running on a normal heating cycle. (We recommend that existing systems are power flushed as per BS 7593 and PAS33 regulations)
4. Drain and flush the system thoroughly to remove the cleaning agent and any debris or contaminants. This is a critical part of the cleaning process and must be carried out correctly. Use a rinse test meter (TDS), such as the Fernox CTM. The reading must be within 10% of the mains ppm value.
5. After the system has been thoroughly flushed and TDS readings are within 10% you can now add Fernox F1. This will protect against the formation of scale, corrosion and microbiological growths. It is crucial however, that for the protector to work correctly, the system must be properly cleansed and flushed.
6. Now attach the label included within the Fernox F1 packaging completed and attached adjacent to the boiler. We recommend inhibitor levels are checked on an annual basis (usually during the service) or sooner if the system content is lost. This should be carried out using a Fernox inhibitor Test Kit. Fernox Technical Service Helpline on 0870 870 0362 for further assistance.

We recommend inhibitor levels are checked on an annual basis (usually during the service) or sooner if the system content is lost.

This should be carried out using a Fernox inhibitor Test Kit. Fernox Technical Service Help line on 0870 870 0362 for further assistance.

13. Control panel - default settings

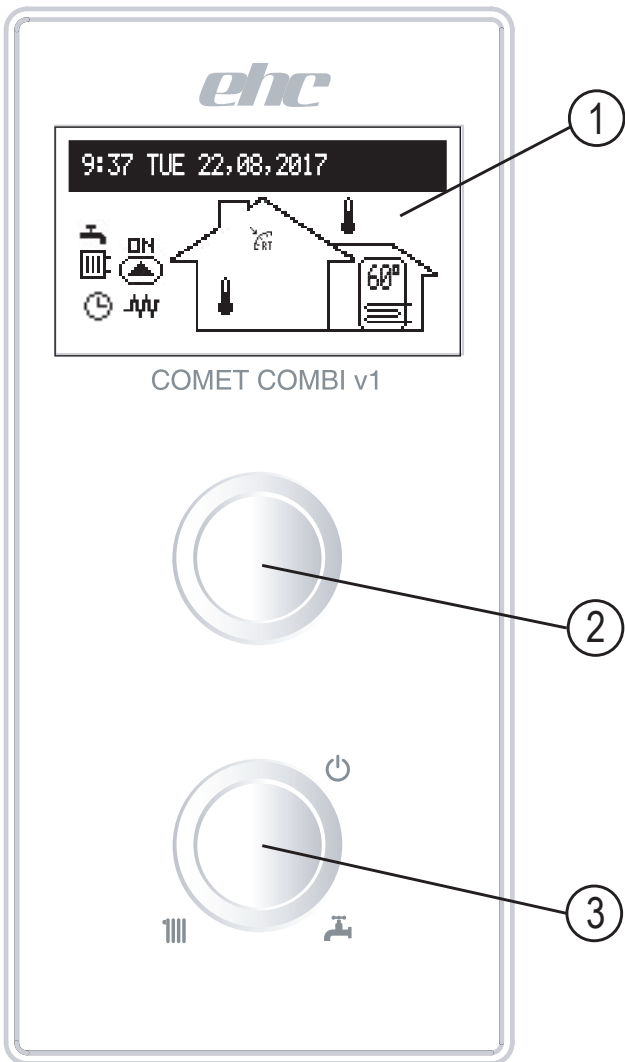

[1] - screen

[2] - navigation dial to preview dial and settings

[3] - operating dial to choose working mode

Err icon indicates boiler's error. To view the error press the navigation dial [2].

Dial 3 changes the mode:

- winter : CH + DHW
- summer : DHW
- off .

Dial 2 changes function screens (by turning left or right) to:

- main function screen: informs about the basic parameters of the boiler (details in the table- p. 21),



SETTINGS: allows to adjust the parameters of the boiler to user's preferences,

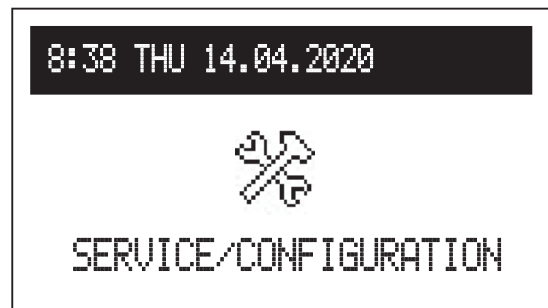

SERVICE/CONFIGURATION: allows configuration of the system heating to the conditions of the facility and preview of boiler's input and output signals,







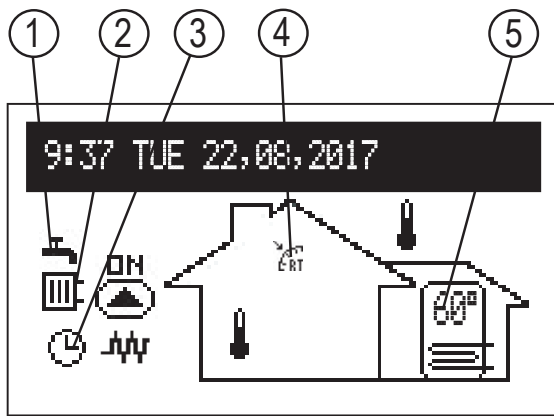



BOOST: allows to quickly switch boost mode

MAIN SCREEN - default settings



- [1] - heat reception HW
- [2] - heat reception CH
- [3] - executing of a heating program
- [4] - room thermostat
- [5] - storage temperature

| Call For Heat | |
|---|--|
|  | Domestic Hot Water |
|  | Central Heating |
| System Icons | |
|  | According to a set daily / weekly schedule |
|  | Tank cleansing |
|  | Circulation pump venting |
| Temperature icon | |
|  | ROOM THERMOSTAT |
| | Default Call for Heat Icon |

| | |
|---|---------------------------------------|
| Err | Device's error indication |
|  | Circulation pump operation indication |
|  | Heating on indication |

SETTINGS - default settings



- **CH PROGRAM** – working program of CH installation
 - WEEKLY selection of the daily programs for each day of the week.
 - Default settings of the boiler: program NO 1 for all week days (editable).

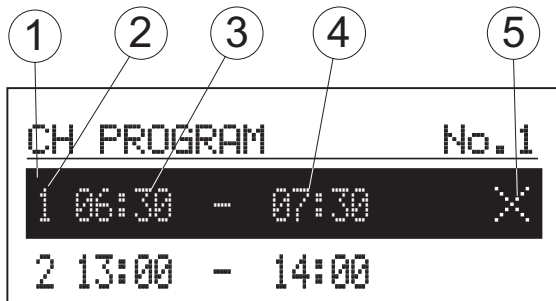

- [1] - time period panel
 [2] - no. of time frame according to schedule (max 5)
 [3] - time of starting the selected temperature
 [4] - time of finishing the selected temperature
 [5] - command (active when editing):
 accept delete add

- NO 1 is a pre-set daily schedule, which operates within the following time frames:

06:30am to 07:30am
 13:00pm to 14:00pm
 20:00pm to 21:00pm

The boiler will maintain the temperature set on the room thermostat.
 The time frames are editable.

- NO 2 ... NO 7 daily schedules to be adjusted in accordance with user's preferences.

To change the parameters for the daily programs select chosen program number and press navigation dial.

The first parameter flashes (starting time)- use the navigation dial to set the new time frame value (hour and minutes separately) by turning the dial left/right and confirm it by pressing the dial again. At the same time next screen starts to flash allowing edition of next parameters (finishing time).

Last editable position is a command. To confirm changes use the dial to select a command:

- add a new time frame
- accept and finish
- delete

If there are no defined time frames, then after selecting 'new' the time frame 00:00am to 23:59pm will be set, which should be edited in accordance with user's needs.

The daily program will be saved to the boiler's settings by pressing the command 'END'.

- **HW PROGRAM** - working program of DHW
 - WEEKLY selection of the daily programs for each day of the week.
 - Default settings of the boiler: program NO 1 for all week days (editable).
 - NOTE: in order to achieve energy efficiency class C (in accordance with ErP directive) program 8 must be set**

No 8 ECO Program Schedule

00:00 - 10.00 Tcwu = 40°C
 10:01 - 11.00 Tcwu = 64°C
 11:01 - 20:00 Tcwu = 40°C
 20:01 - 21:35 Tcwu = 64°C
 21:36 - 23:59 Tcwu = 40°C

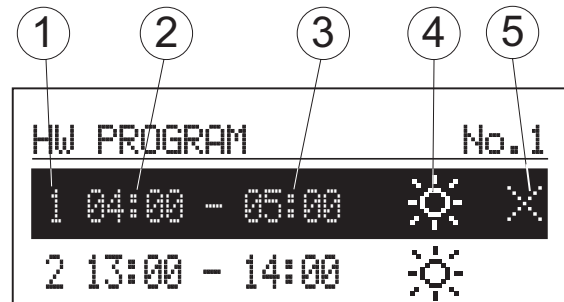

- [1] - no. of time frame according to schedule (max 5)
 [2] - time of starting the selected temperature
 [3] - time of finishing the selected temperature
 [4] - temperature selection: ☀️
 [5] - command (active when editing):
 accept delete add

- NO 1 is a pre-set daily schedule, which operates within the following time frames:

04:00am to 05:00am
 13:00pm to 14:00pm

The boiler will maintain COMFORT temperature in the tank within these time frames. Outside defined time frames the tank will be set at ECONOMY TEMP.

- NO 2 ... NO 7 daily schedules to be adjusted in accordance with user's preferences.

To change the parameters for the daily programs select chosen program number and press navigation dial.

The first parameter flashes (starting time)- use the navigation dial to set the new time frame value (hour and minutes separately) by turning the dial left/right and confirm it by pressing the dial again. At the same time next screen starts to flash allowing edition of next parameters. (finishing time).

Last editable position is a command. To confirm changes use the dial to select a command:

- add a new time frame
- accept and finish
- delete

If there are no defined time frames, then after selecting 'new' the time frame 00:00am to 23:59pm will be set, which should be edited in accordance with user's needs.

The daily program will be saved to the boiler's settings by pressing the command 'END'

- **BOILER TEMPERATURE** [°C] temperature selection for CH installation

- **HW TEMPERATURE** – temperature selection for DHW

- ☀️ – setting economy temperature parameter.
- ☀️ – setting comfort temperature parameter.

- **TANK CLEANSING:**

- Temperature: temperature of the storage tank during cleansing,
- Week day: day of the week of automatic cleansing,
- Time: time of automatic cleansing,
- Working time: cleansing duration,
- Automatic mode: start cleansing automatically at a given time (hour, week day): ON/OFF,
- Activate now: TURN ON/CANCEL.

- **TIME/DATE:**

- setting current system time.

- **INTERFACE:**

- Brightness MIN: setting the brightness of the display in stand by mode.
- Brightness MAX: setting the brightness of the display in working mode.
- Sound: ON/OFF.
- Dial sensitivity: 1-4

- **LANGUAGE:**

- select menu language.

- **SYSTEM:**

- MSK program: shows the boiler controller program version,
- PW program: shows the panel software version,
- Max rated power: shows set boiler power,
- Automatic time change: YES/NO,
- Reset: restart the boiler,
- Factory settings: return to factory settings YES/NO.

BOOST

Below mode is available when room thermostat (RT) is activated
 BOOST: boost heating during 1, 2, or 3 hours



- **BOOST CENTRAL HEATING**

- if there is need for comfortable heating conditions in the room (irrespective of daily schedules settings) we can activate BOOST CENTRAL HEATING mode. It can be activated for 1, 2, or 3 hours (depending on the contact conditions of room thermostat: closed contact=heating)

- **BOOST HOT WATER**

- if there is need for domestic hot water (irrespective of daily schedules settings) we can activate BOOST HOT WATER mode. It can be activated for 1, 2, or 3 hours and it will maintain COMFORT temperature in the tank.

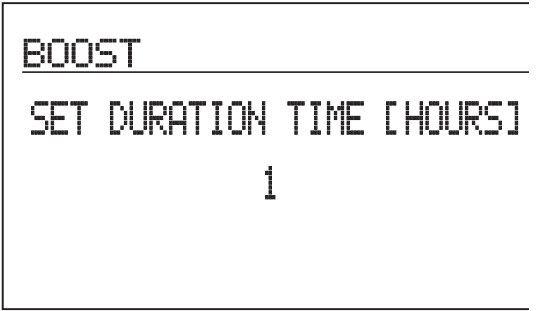
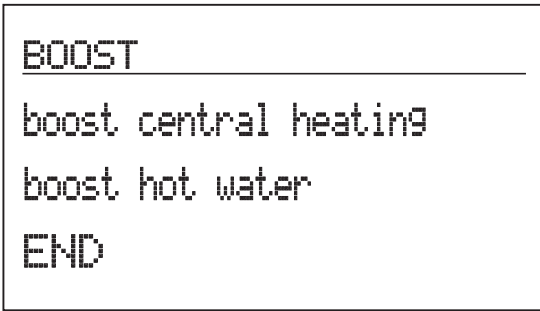

SERVICE / CONFIGURATION - default settings



PREVIEW OF PARAMETERS:
view of input and output signals of the boiler.

CONFIGURATION:
adaptation of the boiler to the heating system in the facility. access code: 987

- **CENTRAL HEATING:**
 - MAX BOILER TEMP: maximum central heating system temperature
 - SET BOILER TEMP: temperature in the installation when operating with manually adjusted parameters (weather compensation NOT IN OPERATION) parameters and in emergency conditions.
 - REGULATION:
 - MANUAL (default) -> the temperature in the installation is equal to manual CH temperature (see above SET BOILER TEMP or alternative way of setting CH temperature: SETTINGS>BOILER TEMPERATURE)
 - WEATHER COMP.-> the temperature in the installation is calculated on the basis of the outside temperature taking into account heating curve (only with O/S activated).
 - OUTSIDE TEMP OFF - outside temperature settings above which central heating circulation is off.

- **HOT WATER TANK:**
 - POWER TEMPERATURE: setting coil's supply temperature.
 - CANCEL - turn off the storage circuit.

** If Storage function is off - menu will only show a possibility to turn it on ('On').*

- **ROOM TEMP:** way of controlling room's temperature
 - TEMP SENSORS:
 - RT -> activation of room thermostat
 - I/S -> activation of internal sensor

- **PUMP:**
 - PUMPS OVER RUN: time to turn the pump on for a short time at a longer standstill (protection against blocking).
 - AUTOMATIC MODE: yes > works according to user's needs / no > works constantly.
 - TYPE: pump's type.
 - REGULATION: specification of pump's configuration
 - VARIABLE P. – pressure difference produced by the pump is maintained at the settings level which changes linearly between ½ H and H. Pressure difference setting is being decreased or increased depending on flow rate. This type of regulation is recommended for installations with traditional radiators, it reduces noises produced by thermostatic valves.
 - CONST P. - pressure difference produced by the pump is maintained at the constant setpoint within efficiency rate for pump's maximal characteristics. This type of regulation is recommended for underfloor wet heating installations, older CH systems with the pipes of larger diameters, or for all other installations with constant characteristics.
 - VENTING: on > venting turns on / off > venting turns off. During venting procedure (10 min) the pump works alternately with a maximal and minimal rotation speed. Thanks to this air bubbles are concentrated and easier to remove from the installation.
 - HMAX [m] - settings of the pump's height for different boiler's outputs

| | | | |
|-------------------|----------|-----------|-------------|
| POWER [kW] | 9 | 12 | 14,4 |
| H MAX [m] | 4 | 6 | 7 |

- **MAX RATED POWER:** setting heater's rated power.

- **COMMUNICATION:**
 - device's number: device's number on the mains (setting '0' turns off the mains service).

- **PRESSURE CONTROL: YES/NO.**

Exit any menu item by pressing 'End' or by pressing and holding the navigation dial. When not operated by the user, main function screen will appear after about 3 min.

| Hot Water Reheat Times (minutes) | | | |
|--|------------|-------------|---------------|
| Boiler Output | 9kW | 12kW | 14.4kW |
| Rehat Time 16°C - 65°C | 76 | 60 | 49 |
| Reheat Time of 70% Volume to 65°C | 52 | 36 | 25 |

13. Control panel- optional settings with OS (outside sensor) and IS (NTC sensor activated)

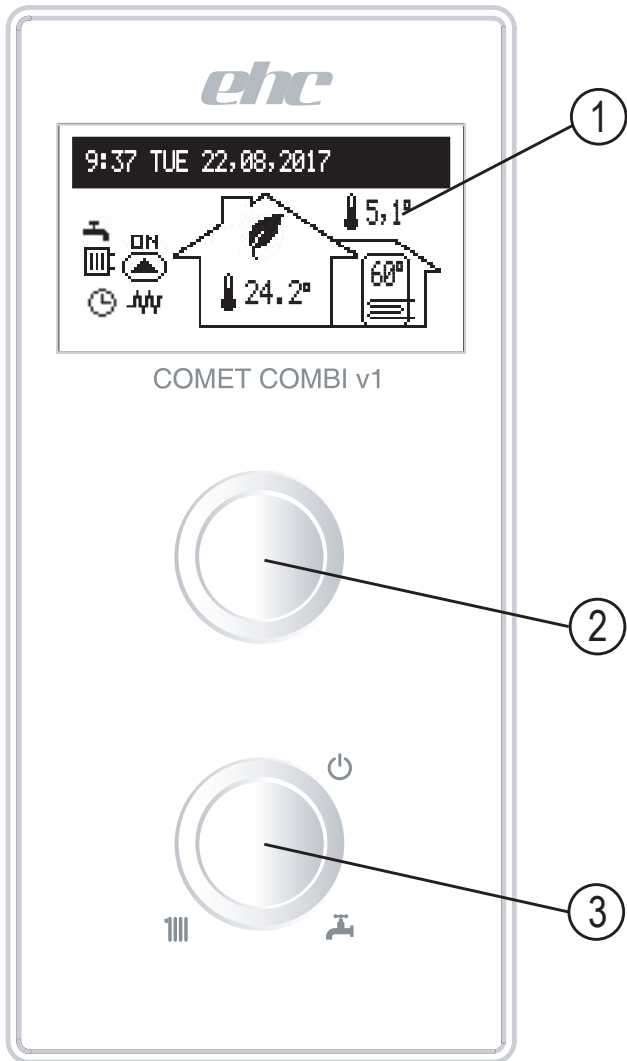

[1] - screen

[2] - navigation dial to preview dial and settings

[3] - operating dial to choose working mode

Err icon indicates boiler's error. To view the error press the navigation dial [2].

Dial 3 changes the mode:

- winter : CH + DHW
- summer : DHW
- off .

Dial 2 changes function screens (by turning left or right) to:

- main function screen: informs about the basic parameters of the boiler (details in the table- p. 22),



SETTINGS: allows to adjust the parameters of the boiler to user's preferences,

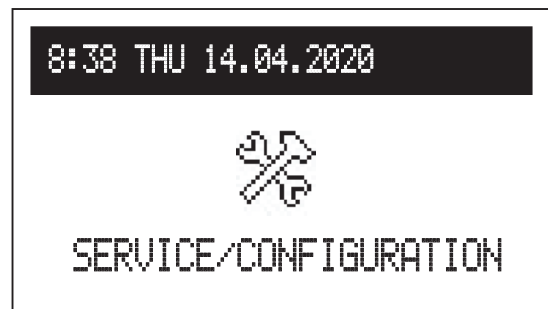

SERVICE/CONFIGURATION: allows configuration of the system heating to the conditions of the facility and preview of boiler's input and output signals,



BOOST/HOLIDAYS/MANUAL: allows to quickly select heating mode.

MAIN SCREEN optional settings with O/S (outside sensor) and I/S (NTC sensor activated)

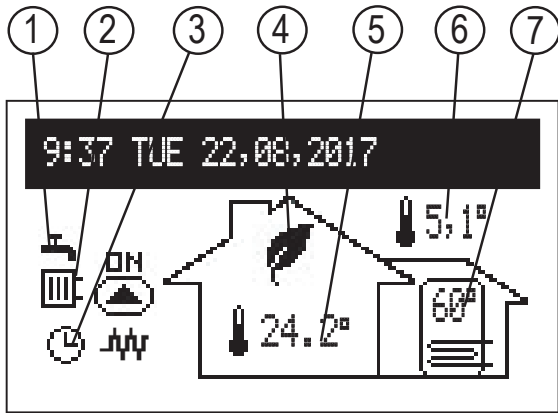

- [1] - heat reception HW
- [2] - heat reception CH
- [3] - executing of a heating program
- [4] - temperature settings for the room
- [5] - room temperature
- [6] - outside temperature
- [7] - storage temperature

| Call for Heat | |
|---------------|---|
| | Hot water heating/ storage heating |
| | Central installation heating |
| System icons | |
| | According to a set daily / weekly schedule |
| | BOOST - keeping the room and storage temperature comfortable |
| | HOLIDAY - keeping the room and storage temperature economical or frost-proof |
| | MANUAL - keeping the set room temperature |
| | TURBO - heating up the maximum parameters until the set room temperature is reached |
| | Implementation of the frost protection program |
| | Tank cleansing |
| | Circulation pump venting |
| | Device's error indication |
| | Circulation pump operation indication |
| | Heating on indication |

| Temperature icons | | |
|-------------------|------------------|-----------------------------------|
| | FROST PROTECTION | Only when NTC Room Sensor is used |
| | ECO TEMP | |
| | COMFORT | |
| | COMFORT PLUS | |
| | COMFORT MINUS | |
| | ROOM THERMOSTAT | Default Call for Heat icon |

SETTINGS optional settings with O/S (outside sensor) and I/S (NTC sensor activated)

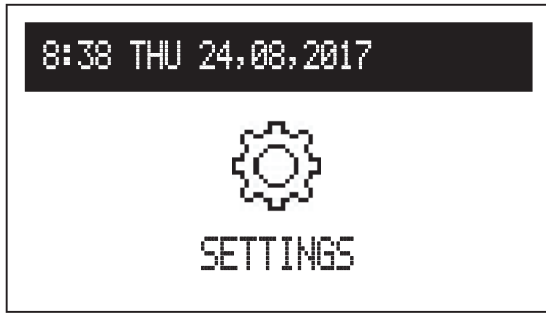

- **CH PROGRAM** – working program of CH installation
 - WEEKLY selection of the daily programs for each day of the week
 - Default settings of the boiler: program NO 1 for all week days (editable).

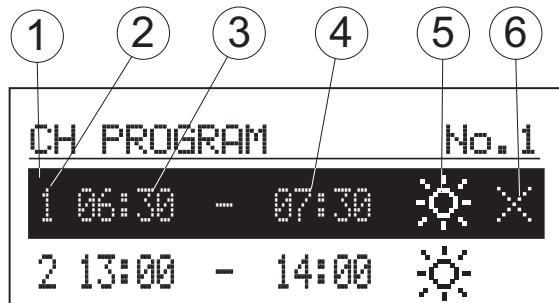

- [1] - time period panel
- [2] - no. of time frame according to schedule (max 5)
- [3] - time of starting the selected temperature
- [4] - time of finishing the selected temperature
- [5] - temperature selection:
- [6] - command (active when editing):
 accept delete add

- NO 1 is a pre-set daily schedule, which operates within the following time frames:
 06:30am to 07:30am
 13:00pm to 14:00pm
 20:00pm to 21:00pm

The boiler will maintain COMFORT temperature within these time frames. Outside defined time frames the boiler will be set at ECONOMY TEMP.

There are 2 additional temperature settings: COMFORT MINUS, COMFORT PLUS which can be selected while defining time frames.

To adjust temperature parameter for COMFORT, COMFORT PLUS, COMFORT MINUS, ECONOMY TEMP go to SETTINGS> ROOM TEMP. The time frames are editable.

- NO 2 ... NO 7 daily schedules to be adjusted in accordance with user's preferences

To change the parameters for the daily programs select chosen program number and press navigation dial.

The first parameter flashes (starting time)- use the navigation dial to set the new time frame value hour and minutes separately) by turning the dial left/right and confirm it by pressing the dial again. At the same time next screen starts to flash allowing edition of next parameters. (finishing time).

Last editable position is a command. To confirm changes use the dial to select a command:

- add a new time frame
- accept and finish
- delete

If there are no defined time frames, then after selecting 'new' the time frame 00:00am to 23:59pm will be set , which should be edited in accordance with user's needs.

The daily program will be saved to the boiler's settings by pressing the command 'END'

- **HW PROGRAM** - working program of DHW
 - WEEKLY selection of the daily programs for each day of the week.
 - Default settings of the boiler: program NO 1 for all week days (editable)
 - NOTE: in order to achieve energy efficiency class C (in accordance with ErP directive) program 8 must be set**

No 8 ECO Program Schedule

| | | | |
|-------|---|-------|-------------|
| 00:00 | - | 10:00 | Tcwu = 40°C |
| 10:01 | - | 11:00 | Tcwu = 64°C |
| 11:01 | - | 20:00 | Tcwu = 40°C |
| 20:01 | - | 21:35 | Tcwu = 64°C |
| 21:36 | - | 23:59 | Tcwu = 40°C |

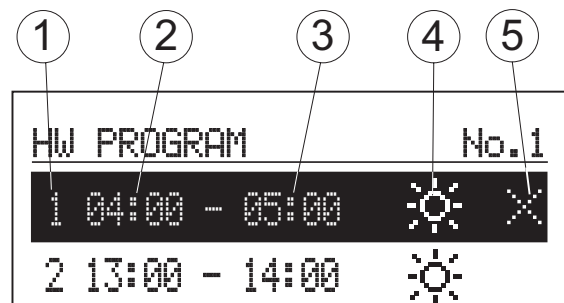

- [1] - no. of time frame according to schedule (max 5)
- [2] - time of starting the selected temperature
- [3] - time of finishing the selected temperature
- [4] - temperature selection:
- [5] - command (active when editing):
 accept delete add

- NO 1 is a pre-set daily schedule, which operates within the following time frames:
 04:00am to 05:00am
 13:00pm to 14:00pm

The boiler will maintain COMFORT temperature in the tank within these time frames. Outside defined time frames the tank will be set at ECONOMY TEMP.

- NO 2 ... NO 7 daily schedules to be adjusted in accordance with user's preferences.

To change the parameters for the daily programs select chosen program number and press navigation dial.

The first parameter flashes (starting time)- use the navigation dial to set the new time frame value (hour and minutes separately) by turning the dial left/right and confirm it by pressing the dial again. At the same time next screen starts to flash allowing edition of next parameters. (finishing time).

Last editable position is a command. To confirm changes use the dial to select a command:

- add a new time frame
- accept and finish
- delete

If there are no defined time frames, then after selecting 'new' the time frame 00:00am to 23:59pm will be set, which should be edited in accordance with user's needs.

The daily program will be saved to the boiler's settings by pressing the command 'END'.

- **ROOM TEMP** (not available when cooperating with external room thermostat (RT):
 - Economy, Comfort -, Comfort, Comfort+: setting room temperature values in available schedules (☀, ☀, ☀, ☀),
 - Boost, Holidays: choose what temperatures are to be set in the programs BOOST ☀,☀,☀ and HOLIDAYS ☀, ☀.

- **HW TEMPERATURE** – temperature selection for DHW
 - ☀ setting economy temperature parameter,
 - ☀ setting comfort temperature parameter.

- **TANK CLEANSING**
 - Temperature: temperature of the storage tank during cleansing,
 - Week day: day of the week of automatic cleansing,
 - Time: time of automatic cleansing,
 - Working time: cleansing duration,
 - Automatic mode: start cleansing automatically at a given time (hour, week day): ON/OFF,
 - Activate now: start cleansing manually (irrespective of a day and time set previously) TURN ON/CANCEL.

- **TIME/DATE:**
 - setting current system time.

- **INTERFACE:**
 - Brightness MIN: setting the brightness of the display in stand by mode.
 - Brightness MAX: setting the brightness of the display in working mode.
 - Sound: yes > on / no > off the acoustic signaling of the dial ON/OFF.
 - Dial sensitivity: 1-4.

- **LANGUAGE:**
 - select menu language.

- **SYSTEM:**
 - MSK program: shows the boiler controller program version,
 - PW program: shows the panel software version,
 - Max rated power: shows set boiler power,
 - Automatic time change: YES/NO,
 - Reset: restart the boiler,
 - Factory settings: return to factory settings YES/NO.

BOOST / HOLIDAYS / MANUAL

Below modes are available only when NTC sensor (I/S) is activated.

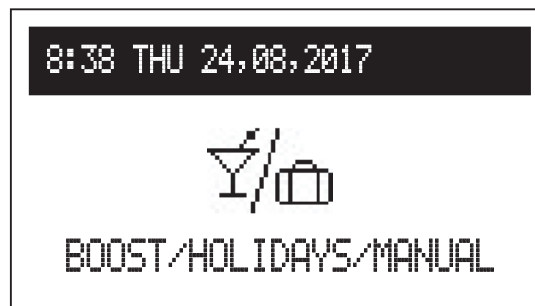

- **BOOST CENTRAL HEATING**

If there is need for comfortable heating conditions in the room (irrespective of daily schedules settings) we can activate BOOST CENTRAL HEATING mode. It can be activated for 1, 2, or 3 hours and it will maintain the temperature value adjusted in SETTINGS > ROOM TEMP > BOOST (☀,☀,☀)

- **BOOST HOT WATER**

If there is need for domestic hot water (irrespective of daily schedules settings) we can activate BOOST HOT WATER mode. It can be activated for 1, 2, or 3 hours and it will maintain COMFORT temperature in the tank.

- **HOLIDAYS**

HOLIDAY mode can be set during longer absence in the facility (selecting time period from 1 to 60 days or until cancelled) The temperature in the facility will be maintained in accordance with selected value in SETTINGS> ROOM TEMP > HOLIDAY > (☀ or ☀)

- **MANUAL**

If the need for required temperature in the facility is different than the one defined in the daily schedules, MANUAL mode will allow selection of manually adjusted temperature, which will be maintained until cancelled.

- **TURBO**

Quick heating up mode with the maximal heating parameters until required room temperature is reached.

* Mode symbol is indicated on the main function screen.

SERVICE / CONFIGURATION optional settings with O/S (outside sensor) and I/S (NTC sensor activated)

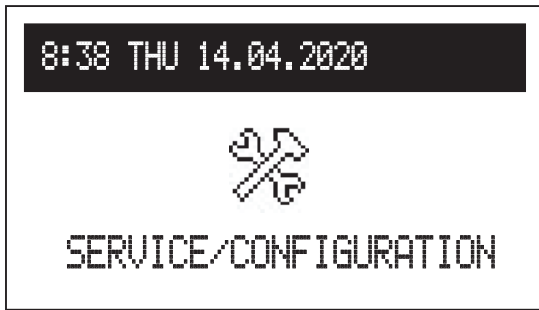

PREVIEW OF PARAMETERS:
view of input and output signals of the boiler.

CONFIGURATION:
adaptation of the boiler to the heating system in the facility. access code: 987

- **CENTRAL HEATING:**
 - WEATHER COMP.: selection heating curve.
 - OFFSET: shift of the heating curve.
 - MAX BOILER TEMP: maximum central heating system temperature
 - SET BOILER TEMP: temperature in the installation when operating with constant parameters and in emergency conditions.
 - REGULATION:
 - MANUAL (default) -> the temperature in the installation is equal to manual CH temperature (see above SET BOILER TEMP or alternative way of setting CH temperature: SETTINGS>BOILER TEMPERATURE)
 - WEATHER COMP.-> the temperature in the installation is calculated on the basis of the outside temperature taking into account heating curve (only with O/S activated).
 - OUTSIDE TEMP OFF - outside temperature settings above which central heating circulation is off.
 - FROST PROTECTION: turn on central heating installation frost protection.

- **HOT WATER TANK:**
 - POWER TEMPERATURE: setting coil's supply temperature.
 - CANCEL - turn off the storage circuit.

** If Storage function is off - menu will only show a possibility to turn it on ('On').*

- **ROOM TEMP:**
 - TEMP SENSORS:
 - RT -> activation room thermostat
 - I/S -> activation internal sensor
 - TEMP CONTROL: YES -> heating turned off after reaching the set room temperature only with TEMP SENSOR > I/S.
 - TEMP HYSTERESIS: room temperature hysteresis only with TEMP SENSOR > I/S

- **PUMP:**
 - PUMPS OVER RUN: time to turn the pump on for a short time at a longer standstill (protection against blocking).
 - AUTOMATIC MODE: yes > works according to user's needs / no > works constantly.
 - TYPE: pump's type.
 - REGULATION: specification of pump's configuration
 - VARIABLE P. – pressure difference produced by the pump is maintained at the settings level which changes linearly between ½ H and H. Pressure difference setting is being decreased or increased depending on flow rate. This type of regulation is recommended for installations with traditional radiators, it reduces noises produced by thermostatic valves.
 - CONST P. - pressure difference produced by the pump is maintained at the constant setpoint within efficiency rate for pump's maximal characteristics. This type of regulation is recommended for underfloor wet heating installations, older CH systems with the pipes of larger diameters, or for all other installations with constant characteristics.
 - VENTING: on > venting turns on / off > venting turns off. During venting procedure (10 min) the pump works alternately with a maximal and minimal rotation speed. Thanks to this air bubbles are concentrated and easier to remove from the installation.
 - HMAX[m] - settings of the pump's height for different boiler's outputs

| | | | |
|-------------------|----------|-----------|-------------|
| POWER [kW] | 9 | 12 | 14,4 |
| H MAX [m] | 4 | 6 | 7 |

- **MAX RATED POWER:** setting heater's rated power.

- **COMMUNICATION:**
 - device's number: device's number on the mains (setting '0' turns off the mains service).

- **PRESSURE CONTROL: YES/NO.**

Exit any menu item by pressing 'End' or by pressing and holding the navigation dial. When not operated by the user, main function screen will appear after about 3 min.

14. Annual Servicing & Maintenance

SERVICING MUST BE CARRIED OUT ANNUALLY & SHOULD ONLY BE CARRIED OUT BY COMPETENT INSTALLERS AND ANY SPARE PARTS USED MUST BE PURCHASED FROM EHC. NEVER BYPASS ANY SAFETY DEVICES OR OPERATE THE UNIT WITHOUT THEM FULLY OPERATIONAL. YOUR GUARANTEE MAY BE VOID WITHOUT PROOF OF ANNUAL SERVICING. THE COMMISSIONING CERTIFICATE SUPPLIED AT THE REAR OF THIS MANUAL SHOULD ALSO BE COMPLETED BY THE INSTALLER.

GENERAL

Servicing should only be carried out by competent installers and only spare parts approved by the manufacturer may be used. Never bypass any of the safety devices and never operate the unit without all of the safety devices being in place and fully operational.

DRAINING

Fully isolate from the electrical supply to prevent the immersion heaters burning out, Isolate the unit from the cold mains. Attach a hose to the draining tap at the bottom of the cylinder ensuring that it reaches to a level below the unit (this will ensure an efficient syphon is set up and the maximum amount of water is drained from the unit). First open the hot tap closest to the unit and then open the draining tap. Warning: water drained off may be very hot! Important: After draining the cylinder do not close the hot tap until the cylinder has fully cooled, failure to follow this instruction may result in damage to the cylinder and will invalidate the guarantee. The primary circuit within this unit can be drained by attaching a hose to the draining tap located below the circulating pump.

ANNUAL MAINTENANCE

This unit requires an annual service in order to ensure safe working and optimum performance and to maintain the guarantee. It is essential that the following checks are performed by a competent installer on an annual basis.

1. The expansion relief valve on the inlet control set should be eased open allowing water to flow for 5 seconds. The valve should then be closed making sure it resets correctly. Repeat this procedure with the pressure / temperature relief valve. Always ensure that the discharge pipework is allowing the water to drain away adequately. If not check for blockages etc. and clear.
2. Ensure that the cylinder thermostat is working correctly and that it is controlling the water at a temperature of between 55°C and 65°C
3. Make sure the pressure in the Primary expansion vessel is charged to 3 bar. Turn off the water supply to the unit and open a hot tap first. The valve on the expansion vessel is a Schrader (standard car tyre) type. Air or CO₂ can be used to pressurise the expansion vessel.
4. Remove the head on the inlet control set by unscrewing, and clean the mesh filter within.
5. The benchmark service record supplied within this manual should be updated at each service.
6. Make sure the pressure in the Secondary expansion vessel is charged to 1.5 bar. De-pressurise the heating circuit before checking & altering the pre-charge pressure.
7. Clean the central heating circuit magnetic filter by isolating and draining the boiler via the drain valve situated below the pump then remove the Hex-head cap from the filter housing.
8. Ensure the central heating circuit is filled to 1.5 bar.
9. Check all electrical connections.



SERVICING MUST BE CARRIED OUT ANNUALLY & SHOULD ONLY BE CARRIED OUT BY COMPETENT INSTALLERS AND ANY SPARE PARTS USED MUST BE PURCHASED FROM EHC. NEVER BYPASS ANY SAFETY DEVICES OR OPERATE THE UNIT WITHOUT THEM FULLY OPERATIONAL.

YOUR GUARANTEE MAY BE VOID WITHOUT PROOF OF ANNUAL SERVICING. THE COMMISSIONING CERTIFICATE SUPPLIED AT THE REAR OF THIS MANUAL SHOULD ALSO BE COMPLETED BY THE INSTALLER.

15. Guarantee

The Comet Combi boiler comes with a 2 year parts & labour warranty and the stainless steel vessel carries a 10 year guarantee against faulty materials or manufacture provided that:

- It has been correctly installed as per this document and all the relevant standards, regulations and codes of practice in force at the time.
- It has not been modified in any way, other than by EHC.
- It has not been misused, tampered with or subjected to neglect.
- It has only been used for the storage of potable water and space heating.
- It has not been subjected to frost damage.
- The unit has been serviced annually.
- The benchmark service record has been filled in after each annual service.
- The guarantee period starts from the date of purchase which should be registered with EHC.
- The extended guarantee is not transferable, and rests with the original householder.
- The system is fed from a public mains water supply.
- Store temperatures do not exceed 70deg C.
- Installations are made only in the UK, Channel Islands & Republic Of Ireland.
- The water supply does not have a Chloride content greater than 250ppm.
- Units are not installed with uncontrollable heat sources (E.g. Wood Burning Stoves).
- The warranty card must be completed and sent back to The Electric Heating Company as soon as possible for registration.
- An internal Magnetic Filter is fitted to the Boiler and it must be cleaned at least annually. (Note: Failure to clean the Magnetic Filter may result in boiler shut-down). Warranty calls will not be covered for this repair

Warranty Exclusions

- Damage to the boiler from poor or incorrect installation work.
- Call out charges that have not been organised by the Electric Heating Company Ltd.
- Water leaks into the boiler. All plumbing connections must be checked at installation and commissioning.
- An internal Magnetic Filter is fitted to the Boiler and it must be cleaned at least annually.(Note: Failure to clean the Magnetic Filter may result in boiler shutdown). Warranty calls will not be covered for this repair.
- Damage caused to parts & equipment by scale build up or system debris / contamination is not covered by this warranty.

For full details of our Terms & Conditions please visit our website www.electric-heatingcompany.co.uk/warranty-terms-conditions/

16. Troubleshooting

SAFETY VALVE CHECKS

Any water coming from either the expansion relief valve or the temperature / pressure relief valve during heat up is indicative of a problem which needs to be identified and rectified. The temperature relief and expansion relief valves should be fully opened, one at a time then both together allowing as much water as possible to flow through the tundish. Check that your discharge pipework is free from debris and is carrying the water away without spillage over the tundish and release the valves and check that they re-seat properly.

17. Technical data

| The Electric Heating Company | | Comet Combination Unit | | |
|--|-----------------|------------------------------------|---------------------------|---------------------------------------|
| Electrical Supply | | 230V~ 50Hz | | |
| Rated power | kW | 9 | 12 | 14,4 |
| Rated current | A | 39 | 52 | 63 |
| Minimum Permitted Cable Diameter | | 10mm | 16mm | |
| Primary system pressure relief valve setting | bar | 3 | | |
| Primary system operating pressure (min) | bar | 0,5 | | |
| Thermal cut-out | °C | t.cut-out 90-99 | | |
| Expansion vessel | 12Ltr | Capacity 12L - Pre-charged 1,5 bar | | |
| Outlet flow temperature | °C | 40 ÷ 85 | | |
| Primary circulating pump | | GRUNDFOS UPM3 | | |
| Safety valve | bar | Opening pressure: 3bar | | |
| Hydraulic connections | | 22 mm Connections | | |
| CYLINDER DETAILS: | | | | |
| Maximum water supply pressure | bar | 12 | | |
| Cylinder operating pressure (Secondary) | bar | 3 | | |
| Cylinder operating pressure (Primary Max) | bar | 2,5 | | |
| Cylinder operating pressure (Secondary Max) | bar | 6 | | |
| Thermostat | °C | 30 - 65 | | |
| Tank capacity | Ltr | 140 | | |
| Temperature-pressure valve | | 95°C / 6bar TP152-1/2 | | |
| Expansion vessel | 2Ltr | 3 bar (charge pressure) | | |
| Hydraulic connections | | Copper pipe ø 22 x 1 | | |
| Optional Immersion Heater | 3000W | 240 Volt | | |
| Weight | Net | kg | 106,8 | |
| | Gross | | 246 | |
| Dimensions | unit dimensions | mm | 1745 x 580 x 630 | |
| Immersion Heater (Optional) | BS/EN | EN60335-2-73:2003+A1 :06+A2:09 | Model & Length | TITANIUM 14" X 1,3/4 3000W 240V AC |

MANUFACTURED TO BS EN 12897:2016

WARNING TO THE USER

1. Do not remove or adjust any component part of this unvented water heater. Contact a fully qualified engineer.
2. If the unvented water heater develops a fault, such as a flow of water from the discharge pipe, turn the heater off and contact a fully qualified engineer.

WARNING TO THE INSTALLER

1. The installation is subject to building regulation approval. Notify the local authority of an intention to install.

2. Use only manufacturers recommended replacement parts.

3. Installed by:.....

Name:.....

Address:.....

Tel:.....

Completion Date:.....

SERVICE RECORD

It is recommended that your hot water system is serviced regularly and that the appropriate Service Record is completed.

Service Provider

Before completing the appropriate Service Record below, please ensure you have carried out the service as described in the manufacturer's instructions.

SERVICE 1 Date _____
Engineer Name _____
Company Name _____
Telephone Number _____
Comments _____

Signature _____

SERVICE 2 Date _____
Engineer Name _____
Company Name _____
Telephone Number _____
Comments _____

Signature _____

SERVICE 3 Date _____
Engineer Name _____
Company Name _____
Telephone Number _____
Comments _____

Signature _____

SERVICE 4 Date _____
Engineer Name _____
Company Name _____
Telephone Number _____
Comments _____

Signature _____

SERVICE 5 Date _____
Engineer Name _____
Company Name _____
Telephone Number _____
Comments _____

Signature _____

SERVICE 6 Date _____
Engineer Name _____
Company Name _____
Telephone Number _____
Comments _____

Signature _____

SERVICE 7 Date _____
Engineer Name _____
Company Name _____
Telephone Number _____
Comments _____

Signature _____

SERVICE 8 Date _____
Engineer Name _____
Company Name _____
Telephone Number _____
Comments _____

Signature _____

SERVICE 9 Date _____
Engineer Name _____
Company Name _____
Telephone Number _____
Comments _____

Signature _____

SERVICE 10 Date _____
Engineer Name _____
Company Name _____
Telephone Number _____
Comments _____

Signature _____



If you require any further assistance:

Telephone: 01698 820533

Fax: 01698 825697

E-mail: info@electric-heatingcompany.co.uk

or visit our website www.electric-heatingcompany.co.uk