

TITAN

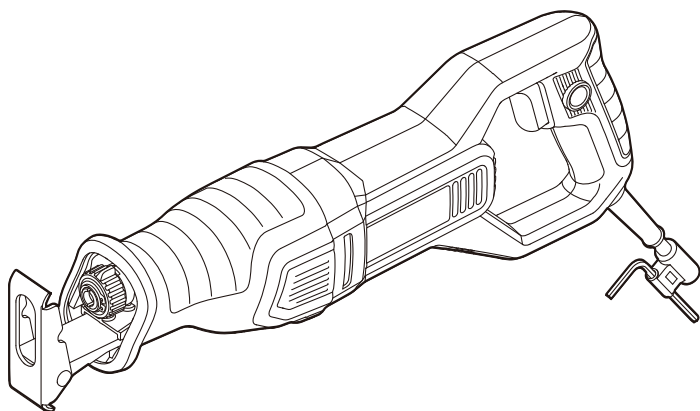

TTB881RSP

EAN: 5059340252209



WARNING! Read the instructions before using the product!

Let's get started...

These instructions are for your safety. Please read through them thoroughly before use and retain them for future reference.



Getting started...	02
Safety	03
Symbols	14
Your product	15
Technical and legal information	16
Before you start	18



In more detail...	23
Product functions	24
Operation	26
Care and maintenance	29
Trouble shooting	33
Guarantee	34
Declarations of conformity	35

Safety warnings

General power tool safety warnings



WARNING! Read all safety warnings, instructions, illustrations and specifications provided with this power tool. Failure to follow all instructions listed below may result in electric shock, fire and/or serious injury. **Save all warnings and instructions for future reference.** The term “power tool” in the warnings refers to your mains-operated (corded) power tool or battery operated (cordless) power tool.”

Work area safety

- 1. Keep work area clean and well lit.** *Cluttered or dark areas invite accidents.*
- 2. Do not operate power tools in explosive atmospheres, such as in the presence of flammable liquids, gases or dust.** *Power tools create sparks which may ignite the dust or fumes.*
- 3. Keep children and bystanders away while operating a power tool.** *Distractions can cause you to lose control.*

Electrical safety

- 1. Power tool plugs must match the outlet. Never modify the plug in any way. Do not use any adapter plugs with earthed (grounded) power tools.** *Unmodified plugs and matching outlets will reduce risk of electric shock.*
- 2. Avoid body contact with earthed or grounded surfaces, such as pipes, radiators, ranges and refrigerators.** *There is an increased risk of electric shock if your body is earthed or grounded.*
- 3. Do not expose power tools to rain or wet conditions.** *Water entering a power tool will increase the risk of electric shock.*
- 4. Do not abuse the cord. Never use the cord for carrying, pulling or unplugging the power tool. Keep cord away from heat, oil, sharp edges or moving parts.** *Damaged or entangled cords increase the risk of electric shock.*
- 5. When operating a power tool outdoors, use an extension cord suitable for outdoor use.** *Use of a cord suitable for outdoor use reduces the risk of electric shock.*
- 6. If operating a power tool in a damp location is unavoidable, use a residual current device (RCD) protected supply.** *Use of an RCD reduces the risk of electric shock.*

Personal safety

- 1. Stay alert, watch what you are doing and use common sense when operating a power tool. Do not use a power tool while you are tired or under the influence of drugs, alcohol or medication. A moment of inattention while operating power tools may result in serious personal injury.**
- 2. Use personal protective equipment. Always wear eye protection. Protective equipment such as a dust mask, non- skid safety shoes, hard hat, or hearing protection used for appropriate conditions will reduce personal injuries.**
- 3. Prevent unintentional starting. Ensure the switch is in the off- position before connecting to power source and/or battery pack, picking up or carrying the tool. Carrying power tools with your finger on the switch or energising power tools that have the switch on invites accidents.**
- 4. Remove any adjusting key or wrench before turning the power tool on. A wrench or a key left attached to a rotating part of the power tool may result in personal injury.**
- 5. Do not overreach. Keep proper footing and balance at all times. This enables better control of the power tool in unexpected situations.**
- 6. Dress properly. Do not wear loose clothing or jewellery. Keep your hair, clothing away from moving parts. Loose clothes, jewellery or longhair can be caught in moving parts.**

- 7. If devices are provided for the connection of dust extraction and collection facilities, ensure these are connected and properly used. *Use of dust collection can reduce dust-related hazards.***
- 8. Do not let familiarity gained from frequent use of tools allow you to become complacent and ignore tool safety principles. *A careless action can cause severe injury within a fraction of a second.***

Power tool use and care

- 1. Do not force the power tool. Use the correct power tool for your application. *The correct power tool will do the job better and safer at the rate for which it was designed.***
- 2. Do not use the power tool if the switch does not turn it on and off. *Any power tool that cannot be controlled with the switch is dangerous and must be repaired.***
- 3. Disconnect the plug from the power source and/or remove the battery pack, if detachable, from the power tool before making any adjustments, changing accessories, or storing power tools. *Such preventive safety measures reduce the risk of starting the power tool accidentally.***
- 4. Store idle power tools out of the reach of children and do not allow persons unfamiliar with the power tool or these instructions to operate the power tool. *Power tools are dangerous in the hands of untrained users.***

5. **Maintain power tools and accessories. Check for misalignment or binding of moving parts, breakage of parts and any other condition that may affect the power tools operation. If damaged, have the power tool repaired before use.** *Many accidents are caused by poorly maintained power tools.*
6. **Keep cutting tools sharp and clean.** *Properly maintained cutting tools with sharp cutting edges are less likely to bind and are easier to control*
7. **Use the power tool, accessories and tool bits etc. in accordance with these instructions, taking into account the working conditions and the work to be performed.** *Use of the power tool for operations different from those intended could result in a hazardous situation.*
8. **Keep handles and grasping surfaces dry, clean and free from oil and grease.** *Slippery handles and grasping surfaces do not allow for safe handling and control of the tool in unexpected situations.*

Service

1. **Have your power tool serviced by a qualified repair person using only identical replacement parts.** *This will ensure that the safety of the power tool is maintained.*

Additional safety warnings for reciprocating saw

- 1. Hold the power tool by insulated gripping surfaces, when performing an operation where the cutting accessory may contact hidden wiring or its own cord.** *Cutting accessory contacting a "live" wire may make exposed metal parts of the power tool "live" and could give the operator an electric shock.*
- 2. Use clamps or another practical way to secure and support the workpiece to a stable platform.** *Holding the workpiece by hand or against your body leaves it unstable and may lead to less of control.*
- 3. Keep hands away from the sawing range. Do not reach under the workpiece.** *Contact with the saw blade can lead to injuries.*
- 4. Apply the machine to the workpiece only when switched on.** *Otherwise there could be danger of kickback if the cutting tool jams in the workpiece.*
- 5. When sawing, the guide plate must always be in contact with the workpiece.** *The saw blade can become wedged and lead to loss of control over the machine.*
- 6. When the cut is completed, switch off the machine and then pull the saw blade out of the cut only after it has come to a standstill.** *In this manner you can avoid kickback and can place down the machine safely .*

7. *Use only undamaged saw blades that are in perfect condition. Bent or dull saw blades can break, negatively influence the cut, or lead to kickback.*
8. *Do not brake the saw blade to a stop by applying side pressure after switching off. The saw blade can be damaged, break or cause kickback.*
9. *Do not support the workpiece with your hand or foot. Do not touch objects or the floor with the saw running. Danger of kickback.*
10. *Use suitable detectors to determine if utility lines are hidden in the work area or call the local utility company for assistance. Contact with electric lines can lead to fire and electric shock. Damaging a gas line can lead to explosion. Penetrating a water line cause property damage or may cause an electric shock.*
11. *When working with the machine, always hold it firmly with both hands and provide a secure stance. The power tool is guided more securely with both hands.*

The following information applies to professional users only but is good practice for all users:

Additional safety warning for construction dust

The updated Control of Substances Hazardous to Health Regulations 1st October 2012 now also targets to reduce the risks associated with silica, wood and gypsumdusts. Construction workers are one of the at-risk groups within this because of the dust that they breathe: silica dust is not just a nuisance; it is a real risk to your lungs!

Silica is a natural mineral present in large amounts in things like sand, sandstone and granite. It is also commonly found in many construction materials such as concrete and mortar. The silica is broken into very fine dust (also known as Respirable Crystalline Silica or RCS) during many common tasks such as cutting, drilling and grinding. Breathing in very fine particles of crystalline silica can lead to the development of: Lung cancer Silicosis Chronic Obstructive Pulmonary Disorder/Chronic Obstructive Pulmonary Disease (COPD) and breathing in fine particles of wood dust can lead to the development of Asthma. The risk of lung disease is linked to people who regularly breathe construction dust over a period of time, not on the odd occasion.

To protect the lung, the COSHH Regulations sets a limit on the amount of these dusts that you can breathe (called a Workplace Exposure Limit or WEL) when averaged over a normal working day. These limits are not a large amount of dust: when compared to a penny it is tiny – like a small pinch of salt: This limit is the legal maximum; the most you can breathe after the right controls have been used.

How to reduce the amount of dust?

1. *Reduce the amount of cutting by using the best sizes of building products. Use a less powerful e.g. a block cutter instead of angle grinder.*
2. *Using a different method of work altogether – e.g. using a nail gun to direct fasten cable trays instead of drilling holes first.*
3. *Please always work with approved safety equipment, such as those dust masks that specially designed to filter out microscopic particles and use the dust extraction facility at all time.*

*For more information please see the HSE website:
<http://www.hse.gov.uk/construction> or <http://www.hse.gov.uk/pubns/cis69.pdf>*



WARNING! Some dust created by power sanding, sawing, grinding, drilling and other construction activities contains chemicals known to cause cancer, birth defects or other reproductive harm. Some examples of these chemicals are:

- Lead from lead-based paint
- Crystalline silica from bricks and cement and other masonry products
- Arsenic and chromium from chemically-treated timber

Your risk from these exposures varies, depending upon how often you do this type of work. To reduce your exposure to these chemicals:

- Work in a well-ventilated area.
- Work with approved protective equipment, such as those dust masks that are specially designed to filter microscopic particles.

Vibration

The European Physical Agents (Vibration) Directive has been brought in to help reduce hand arm vibration syndrome injuries to power tool users. The directive requires power tool manufacturers and suppliers to provide indicative vibration test results to enable users to make informed decisions as to the period of time a power tool can be used safely on a daily basis and the choice of tool.

See technical specifications in the instruction manual for the vibration levels of your tool.

The declared vibration emission value should be used as a minimum level and should be used with the current guidance on vibration.

Calculating the actual period of use can be difficult and the HSE website has further information.

While working with this power tool, hand/arm vibrations occur. Adopt the correct working practices in order to reduce the exposure to vibration. This tool may cause hand-arm vibration syndrome if its use is not adequately managed.

Helping to minimise your vibration exposure risk. ALWAYS use sharp chisels, drills and blades. Maintain this tool in accordance with these instructions and keep well lubricated (where appropriate).

Avoid using tools in temperatures of 10°C or less. Plan your work schedule to spread any high vibration tool use across a number of days.



NOTE: The use of other tools will reduce the users' total working period on this tool.

Health surveillance

All employees should be part of an employer's health surveillance scheme to help identify any vibration related diseases at an early stage, prevent disease progression and help employees stay in work.

Residual risks

Even if you are operating this product in accordance with all the safety requirements, potential risks of injury and damage remain. The following dangers can arise in connection with the structure and design of this product:

- 1. Injuries and damage to property due to broken attachments or the sudden impact of hidden objects during use.*
- 2. Danger of injury and property damage caused by flying objects or poor power tool accessories.*

Symbols

On the product, the rating label and within these instructions you will find among others the following symbols and abbreviations. Familiarise yourself with them to reduce hazards like personal injuries and damage to property.



Read the instruction manual



Wear eye protection



Wear hearing protection.



Wear a dust mask.



Wear protective gloves



For wood cutting



For metal cutting

yyWxx

Manufacturing date code: Year of manufacturing (20yy) and week of manufacturing (Wxx)



The product complies with the applicable European directives and an evaluation method of conformity for these directives was done.



UK Conformity Assessed

Your product

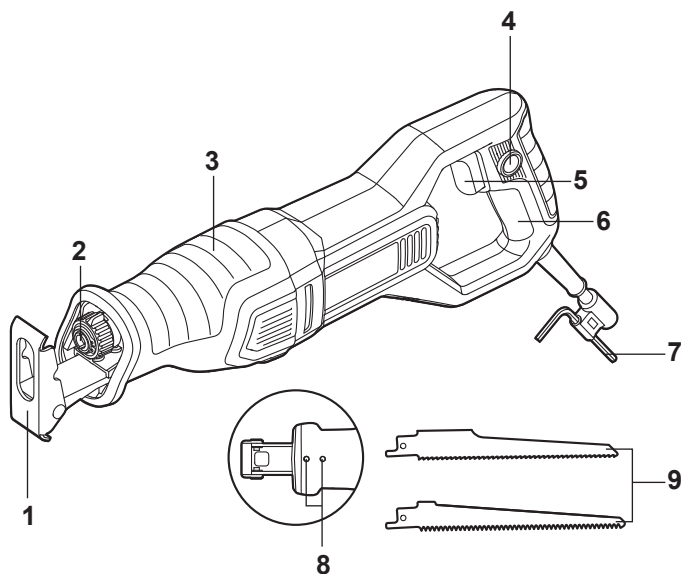

1. Guide plate
2. Tool-less blade clamp sleeve
3. Gripping surface
4. Lock-on button
5. On/off switch
6. Main handle
7. Hex key
8. Guide plate release screws
9. Blades x 2 (1 x metal blade, 1 x wood blade)

Technical specifications

Reciprocating saw

Rated voltage, frequency:	220 -240 V~, 50 Hz
Rated power input:	850 W
Rated no load speed n_0 :	0 - 3000 /min
Stroke length:	25 mm
Cutting Capacity:	
in wood:	100mm
in metal:	12mm
in aluminum:	20mm
Weight:	2.17 kg

NOISE DATA

A weighted sound pressure:	$L_{pA}=95.0$ dB(A)
A weighted sound power:	$L_{wA}=106.0$ dB(A)
Uncertainty:	K_{pA} & $K_{wA}=3$ dB(A)

The noise for the operator may exceed 80 dB(A) and ear protection measures are necessary.

VIBRATION DATA

Cutting boards with the supplied saw blade:	$a_{h,B}=25.68$ m/s ²
Cutting wooden beams with the supplied saw blade:	$a_{h,WB}=32.54$ m/s ²
Uncertainty:	$K=1.5$ m/s ²

The declared vibration total values and the declared noise emission values have been measured in accordance with a standard test method (EN62841-1/EN62841-2-11) and may be used for comparing one tool with another; they may also be used in a preliminary assessment of exposure.



WARNING! The vibration and noise emissions during actual use of the power tool can differ from the declared values depending on the ways in which the tool is used especially what kind of workpiece is processed; and need to identify safety measures to protect the operator that are based on an estimation of exposure in the actual conditions of use (taking account of all parts of the operating cycle such as the times when the tool is switched off and when it is running idle in addition to the trigger time).

RATING LABEL EXPLANATION

TTB881RSP = MODEL NUMBER

TT= TITAN

B= 240V AC

881= Version Number

RSP = RECIPROCATING SAW

Unpack

- Unpack all parts and lay them on a flat, stable surface.
- Remove all packing materials and shipping devices if applicable.
- Make sure the delivery contents are complete and free of any damage. If you find that parts are missing or show damage do not use the product but contact your dealer. Using an incomplete or damaged product represents a hazard to people and property.
- Ensure that you have all the accessories and tools needed for assembly and operation. This also includes suitable personal protective equipment.



WARNING! The product and the packaging are not children's toys! Children must not play with plastic bags, sheets and small parts! There is a danger of choking and suffocation!

You will need

(items not supplied)

Suitable personal protective equipment

(items supplied)

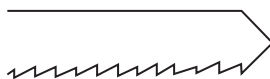

Saw blade (for wood x1)

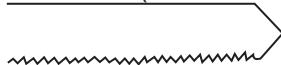

Saw blade (for metal x1)

Saw blades

Different saw blades can be used with this product depending on the workpiece material.



WARNING! Always use saw blades according to the intended use! For example, never use a saw blade intended for working on wood for working on metal or vice versa!

Observe the technical requirements of this product (see section Technical specifications) when purchasing and using saw blades!

Some saw blades are very sharp and become hot during use! Handle them carefully! Wear protective gloves when handling saw blades in order to avoid injuries like burns and cuts!

To install the saw blade

Use one hand to rotate the tool-less blade clamp sleeve (2) in the direction of the arrow marked on the blade clamp and then hold it in place. (Fig.1)

Use the other hand to insert the saw blade (9) into the blade clamp (2) as far as possible.

Release the tool-less blade clamp sleeve (2), and the blade (9) should be locked in place automatically. (Fig.2)

Try to push in and pull out blade (9) to check whether it is locked correctly.



NOTE: The blade may be installed with the teeth pointing up or down, according to the needs of the cutting operation.

To remove the saw blade

Use one hand to rotate the tool-less blade clamp sleeve (2) in the direction of the arrow marked on the blade clamp and hold it.

Remove the saw blade (9) from the blade clamp (2).

Release the tool-less blade clamp sleeve (2).

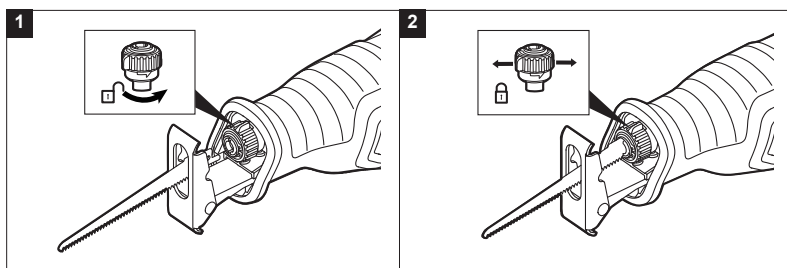

Connection to the power supply

1. Make sure the on/off switch (5) is in its off position.
2. Connect the plug with a suitable socket.



WARNING! Check the voltage! The voltage must comply with the information on the rating label!

3. Your product is now ready to be used.



In more detail...

Product functions	24
Operation	26
Care and maintenance	29
Trouble shooting	33
Guarantee	34
Declarations of conformity	35

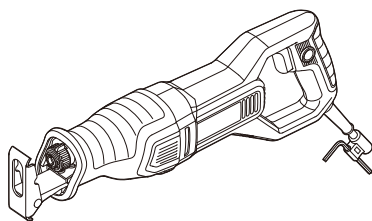

Intended use

This tool is intended for cutting wood and similar material e.g. MDF and chipboard, plastic and metal using the respective saw blade. The product must be used with the guide plate (1) laying flat against the workpiece. It may not be used as a stationary product on a work bench.

Stroke length adjustment

Loosen the guide plate release screws (8) by turning them counterclockwise with the supplied hex key (7) and slide the guide plate (1) to the desired position. (Fig.3)

Tighten the guide plate release screws (8) by turning them clockwise with the supplied hex key (7) to lock the guide plate (1) in the desired position.



WARNING! Make sure that the front end of the blade extends through the guide plate for the entire stroke length. Do not use speciality blades that are very short or those with significant tilt. The blade must not contact the guide plate. A blade that is too short or is tilted could jam inside the guide plate and then snap, causing damage to the tool and possible personal injury.

When cutting pipes or other materials with multiple layers, always ensure that the saw blade is long enough to penetrate completely through the cut, otherwise the tool may kick back (Fig.4, Fig.5)

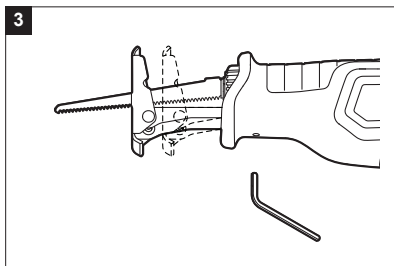

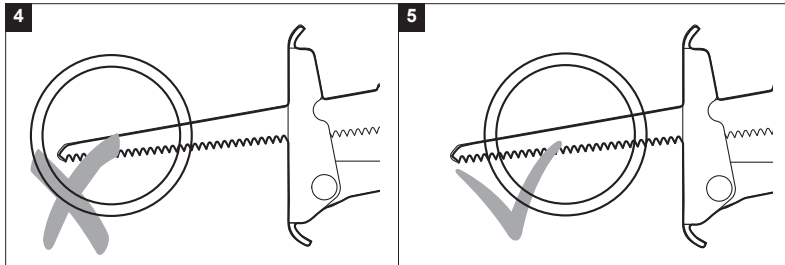

On/off switch

Operate the product either in instant or continuous mode.

Instant mode

Switch the tool on by pressing the on/off switch (5).

Switch the tool off by releasing the on/off switch (5).

Continuous mode

Switch the tool on by pressing the on/off switch (5) and hold it in position.

Press the lock-on button (4) to lock the on/off switch (5). The on/off switch is now locked on for continuous use. The on/off switch can be released.

Depress and release the on/off switch (5) to switch the tool off.

Speed control

The on/off switch (5) is combined with a speed control. Adjust the speed directly with the on/off switch (5). The speed is controlled by how far the switch (5) is pressed.

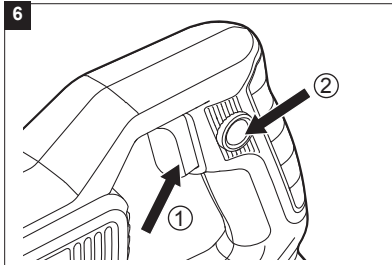

General cutting

Insert the saw blade (9) according to the intended application.

Hold the product with one hand on the main handle (6) and with the other hand on the gripping surface (3) (Fig.7).

Switch the product on and wait until it runs at full speed before placing it on the workpiece.

Place the guide plate (1) flat on the workpiece and move the product at an even speed.



WARNING! Always ensure the guide plate lays flat on the workpiece during operation! Do not try to make cuts with the product only held by hand!

1. Insert the saw blade (9) according to the intended application.

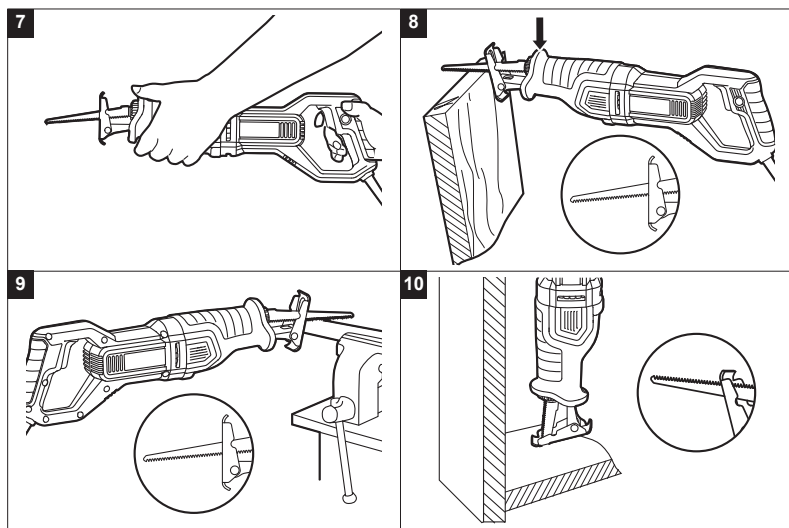

2. Cut in the direction of the wood grain whenever possible to avoid jamming the saw blade (9) and fraying edges.

Pocket cutting

Use the following method to start a cut in the centre of the workpiece.

Use a suitable drill to drill a hole of at least 25 mm on the inside edge of the cutting line.

Insert the saw blade (9) that is fitted to the product into the hole and ensure it does not touch the workpiece.

Switch the product on and wait until it runs at full speed before moving the product.

Cut out the marked section.



WARNING! Always ensure the guide plate lays flat on the workpiece during operation! Do not try to make cuts with the product only held by hand!

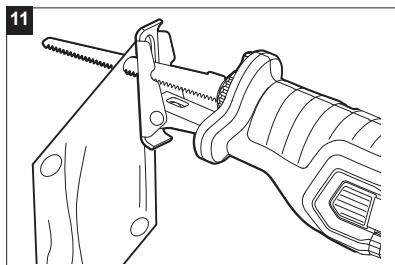

After use

1. Switch the product off, disconnect it from the power supply and let it cool down.
2. Check, clean and store the product as described below.

The golden rules for care



WARNING! Always switch the product off, disconnect the product from the power supply and let the product cool down before performing inspection, maintenance and cleaning work!

- 1 Keep the product clean. Remove debris from it after each use and before storage.
- 2 Regular and proper cleaning will help ensure safe use and prolong the life of the product.
- 3 Inspect the product before each use for worn and damaged parts. Do not operate it if you find broken and worn parts.



WARNING! Only perform repairs and maintenance work according to these instructions! All further works must be performed by a qualified specialist!

General cleaning



NOTE: Do not use chemical, alkaline, abrasive or other aggressive detergents or disinfectants to clean this product as they might be harmful to its surfaces.

- Clean the product with a dry cloth. Use a brush for areas that are hard to reach.
- In particular, clean the air vents after every use with a cloth and brush.
- Remove stubborn dirt with high pressure air (max. 3 bar).

- Check for worn or damaged parts. Replace worn parts as necessary or contact an authorised service centre for repair before using the product again.

Maintenance

Before and after each use, check the product and accessories (or attachments) for wear and damage. If required, exchange them for new ones as described in this instruction manual. Observe the technical requirements.

Power cord

If the supply cord of this tool is damaged, it must be replaced by a specially prepared cord available through the service organisation

Plug replacement

If you need to replace the fitted plug, then follow the instructions below.

IMPORTANT: The wires in the mains lead are coloured in accordance with the following code:

Blue – Neutral Brown – Live

As the colours of the wire in the mains lead of this product may not correspond with the coloured marking identifying the terminals in your plug, proceed as follows. The wire, which is coloured blue, must be connected to the terminal, which is marked with N or coloured black. The wire, which is coloured brown, must be connected to the terminal, which is marked L or coloured red.

13AMP fuse approved to BS 1362

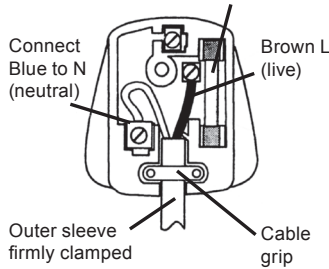

WARNING! Never connect live or neutral wires to the earth terminal of the plug, which is marked with E.

Only fit an approved 13A BS 1363 or BS 1363/A plug and the correctly rated fuse. If in doubt, consult a qualified electrician.



NOTE: If a moulded plug is fitted and has to be removed take great care in disposing of the plug and severed cable, it must be destroyed to prevent engaging into a socket.

Recycling and disposal



Waste electrical products should not be disposed of with household waste. Please recycle where facilities exist. Check with your Local Authority or local store for recycling advice.

Repair

- This product does not contain any parts that can be repaired by the consumer. Contact an authorised service centre or a similarly qualified person to have it checked and repaired.

Storage

- Switch the product off and disconnect it from power supply.
- Clean the product as described above.
- Store the product and its accessories in a dark, dry, frost-free, well-ventilated place.
- Always store the product in a place that is inaccessible to children.
- We recommend using the original package for storage or covering the product with a suitable cloth or enclosure to protect it against dust.

Transportation

- Switch the product off and disconnect it from power supply before transporting it anywhere.
- Attach transportation guards, if applicable.
- Always carry the product by its handle.
- Protect the product from any heavy impact or strong vibrations which may occur during transportation in vehicles.
- Secure the product to prevent it from slipping or falling over.

Trouble shooting

Suspected malfunctions are often due to causes that the users can fix themselves. Therefore check the product using this section. In most cases the problem can be solved quickly.



WARNING! Only perform the steps described within these instructions! All further inspection, maintenance and repair work must be performed by an authorized service centre or a similarly qualified specialist if you cannot solve the problem yourself!

Problem	Possible cause	Solution
Product does not start	Not connected to power supply	Connect to power supply
	Power cord or plug is defective	Check by a specialist electrician.
	Other electrical defect to the product	Check by a specialist electrician
Product does not reach full power	Extension cord not suitable for operation with this product	Use a proper extension cord
	Power source (e.g. generator) has too low voltage	Connect to another power source
	Air vents are blocked	Clean the air vents
Unsatisfactory result	Blade is worn	Replace with a new one
	Blade not suitable for workpiece material	Use proper blade

Guarantee

We take special care to select high quality materials and use manufacturing techniques that allow us to create products incorporating design and durability. This product (TITAN Reciprocating Saw) has a manufacturer's guarantee of 2 years against manufacturing defects, from the date of purchase (if bought in store) or date of delivery (if bought online), at no additional cost.

To make a claim under this guarantee, you must present your proof of purchase (such as a sales receipt, purchase invoice or other evidence admissible under applicable law), please keep your proof of purchase in a safe place. For this guarantee to apply, the product you purchased must be new, it will not apply to second hand or display products. Unless stated otherwise by applicable law, any replacement product issued under this guarantee will only be guaranteed until expiry of the original period guarantee period.

This guarantee covers product failures and malfunctions provided the product was used for the purpose for which it is intended and subject to installation, cleaning, care and maintenance in accordance with the information contained in these terms and conditions, in the user manual and standard practice, provided that standard practice does not conflict with the user manual.

This guarantee does not cover defects and damage caused by normal wear and tear or damage that could be the result of improper use, faulty installation or assembly, neglect, accident, misuse, or modification of the product. Unless stated otherwise by applicable law, this guarantee will not cover, in any case, ancillary costs (shipping, movement, costs of uninstalling and reinstalling, labour etc), or direct and indirect damage.

This guarantee does not cover defects and damage caused by or resulting from:

Normal wear and tear

Overload, misuse or neglect

Repairs attempted by anyone other than an authorised agent

Cosmetic damage

Damage caused by foreign objects, substances or accidents

Accidental damage or modification

Failure to follow manufacturer's guidelines



Loss of use of the goods

If the product is defective, we will, within a reasonable time, repair or replace it.

Rights under this guarantee are enforceable in the country in which you purchased this product. Guarantee related queries should be addressed to the store you purchased this product from.

The guarantee is in addition to and does not affect your statutory rights.

EC declaration of conformity

 (UK) DECLARATION OF CONFORMITY		
Product		
<ul style="list-style-type: none"> • 850W RECIPROCATING SAW • MRS850 / TTB881RSP • Serial number 00001-99999 		
Name and address of the manufacturer or his authorised representative:		
Kingfisher International Products Limited 3 Sheldon Square London W2 6PX United Kingdom		
This declaration of conformity is issued under the sole responsibility of the manufacturer.		
Object of the declaration		
Product	Model	EAN
850W Single Pendulum Recip Saw	TTB881RSP MRS850	5059340252209 5059340252186
The object of the declaration described above is in conformity with the relevant legislation:		
Supply of Machinery (Safety) Regulations 2008 as amended Electromagnetic Compatibility Regulations 2016 as amended The Restriction of the use of Certain Hazardous Substances in Electrical and Electronic Equipment Regulations 2012 as amended		
References to the relevant designated standards used or references to the other technical specifications in relation to which conformity is declared:		
EN 62841-1:2015	BS EN 62841-1:2015	
EN 62841-2-11:2016+A1:2020	BS EN 62841-2-11:2016+A1:2020	
EN 55014-1:2017+A11:2020	BS EN 55014-1:2017+A11:2020	
EN 55014-2:2015	BS EN 55014-2:2015	
EN IEC 61000-3-2:2019	BS EN IEC 61000-3-2:2019	
EN 61000-3-3:2013+A1:2019	BS EN 61000-3-3:2013+A1:2019	
Authorized Signatory and technical file holder Kingfisher International Products Limited 3 Sheldon Square London W2 6PX United Kingdom		
		
David Awe Group Quality Director		
		on: 31/12/2021



(EN) EU DECLARATION OF CONFORMITY
 (FR) DÉCLARATION UE DE CONFORMITÉ
 (PL) DEKLARACJA ZGODNOŚCI UE
 (RO) DECLARAȚIA DE CONFORMITATE UE
 (ES) DECLARACIÓN UE DE CONFORMIDAD
 (PT) DECLARAÇÃO DE CONFORMIDADE UE

Product/ Produit/ Produkt/Produsul/Producto/Produto

- RECIPROCATING SAW / SCIE SABRE / PIŁA SZABLASTA / FIERĂSTRĂU SABIE / SIERRA SABLE / SERRA DE SABRE
- MRS850 / TTB881RSP
- Serial number 00001-99999

Name and address of the manufacturer or his authorised representative:

Nom et adresse du fabricant ou de son mandataire:

Nazwa i adres producenta lub jego upoważnionego przedstawiciela:

Denumirea și adresa producătorului sau a reprezentantului său autorizat:

Nombre y dirección del fabricante o de su representante autorizado:

Nome e endereço do fabricante ou do respetivo mandatário:

Kingfisher International Products B.V.,
 Rapenburgerstraat 175E,
 1011 VM Amsterdam,
 The Netherlands

This declaration of conformity is issued under the sole responsibility of the manufacturer.

La présente déclaration de conformité est établie sous la seule responsabilité du fabricant.

Niniejsza deklaracja zgodności wydana zostaje na wyłączną odpowiedzialność producenta.

Prezenta declarație de conformitate este emisă pe răspunderea exclusivă a producătorului.

La presente declaración de conformidad se expide bajo la exclusiva responsabilidad del fabricante.

A presente declaração de conformidade é emitida sob a exclusiva responsabilidade do fabricante.

Object of the declaration/ Objet de la déclaration/ Przedmiot deklaracji/ Obiectul declarației/ Objeto de la declaración/ Objeto da declaração

Product/ Produit/ Produkt/
Produsul/ Producto/ Produto

Model/ Modèle/ Model/
Modelul/ Modelo/ Modelo

EAN

RECIPROCATING SAW
/ SCIE SABRE / PIŁA
SZABLASTA / FIERĂSTRĂU
SABIE / SIERRA SABLE /
SERRA DE SABRE

TTB881RSP

MRS850

5059340252209
5059340252216
5059340252186
5059340252193

<p>The object of the declaration described above is in conformity with the relevant Union harmonisation legislation: L'objet de la déclaration décrit ci-dessus est conforme à la législation d'harmonisation de l'Union applicable: Wymieniony powyżej przedmiot niniejszej deklaracji jest zgodny z odnośnymi wymaganiami unijnego prawodawstwa harmonizacyjnego: Obiectul declarației descris mai sus este în conformitate cu legislația relevantă de armonizare a Uniunii: El objeto de la declaración descrita anteriormente es conforme con la legislación de armonización pertinente de la Unión: O objeto da declaração acima descrito está em conformidade com a legislação de harmonização da União aplicável:</p>	
2006/42/EC as amended	Machinery Directive
2014/30/EU as amended	Directive Electromagnetic compatibility
2011/65/EU as amended	Directive Restriction of the use of certain hazardous substances in electrical and electronic equipment
Directive 2006/42/CE relative aux machines	
2014/30 / UE telle que modifiée Directive Compatibilit�� electromagn��tique	
Directive 2011/65/UE relative � la limitation de l'utilisation de certaines substances dangereuses dans les �quipements �lectriques et �lectroniques	
2006/42/WE w zmienionej dyrektywie maszynowej	
2014/30 / UE ze zmianami Dyrektywa Kompatybilno�� elektromagnetyczna	
2011/65 / UE ze zmianami Dyrektywa Ograniczenie stosowania niekt�rych niebezpiecznych substancji w sprz�cie elektrycznym i elektronicznym	
2006/42/CE, astfel a fost modificat� Directiva privind echipamentele	
2014/30/UE, astfel a fost modificat� Directiva privind compatibilitatea electromagnetice	
2011/65/UE, astfel a fost modificat� Directiva privind limitarea utilizării anumitor substanțe periculoase �n echipamentele electrice �i electronice	
Directiva sobre maquinaria modificada 2006/42/CE	
2014/30/UE modificada Directiva Compatibilidad electromagn�tica	
2011/65/UE modificada Directiva Restricci�n del uso de determinadas sustancias peligrosas en equipos �lectricos y electr�nicos	
2006/42/CE como diretiva de m�quinas alteradas	
2014/30/UE como altera��o da compatibilidade eletromagn�tica	
2011/65/UE como restri��o diretiva alterada da utiliza��o de certas subst�ncias perigosas em equipamentos �tricos e eletr�nicos	

References to the relevant harmonised standards used or references to the other technical specifications in relation to which conformity is declared:

Références des normes harmonisées pertinentes appliquées, y compris la date de celles-ci, ou des autres caractéristiques techniques, y compris la date de celles-ci, par rapport auxquelles la conformité est déclarée:

Odwołania do odnośnych norm zharmonizowanych, które zastosowano, wraz z datą normy, lub do innych specyfikacji technicznych, wraz z datą specyfikacji, w odniesieniu do których deklarowana jest zgodność:

Trimiteri la standardele armonizate relevante folosite, inclusiv data standardului, sau trimeri la celelalte specificații tehnice, inclusiv data specificațiilor, în legătură cu care se declară conformitatea:

Referencias a las normas armonizadas pertinentes utilizadas, incluidas las fechas de las normas, o referencias a las otras especificaciones técnicas, incluidas las fechas de las especificaciones, respecto a las cuales se declara la conformidad:

Referências às normas harmonizadas aplicáveis utilizadas, incluindo a data da norma, ou às outras especificações técnicas, incluindo a data da especificação, em relação às quais é declarada a conformidade:

EN 62841-1:2015

EN 62841-2-11:2016+A1:2020

EN 55014-1:2017+A11:2020

EN 55014-2:2015

EN IEC 61000-3-2:2019

EN 61000-3-3:2013+A1:2019

Authorized Signatory and technical file holder/ Signataire et responsable de la documentation technique autorisé/ Podmiot uprawniony do wystawienia i adres przechowywania dokumentacji technicznej/ Semnatar autorizat și deținătorul dosarului tehnic/ Firmante autorizado y titular del expediente técnico/Signatário autorizado e detentor da ficha técnica:

Kingfisher International Products B.V.,
Rapenburgerstraat 175E,
1011 VM Amsterdam,
The Netherlands



David Awe
Group Quality Director

on: 31/12/2021

TITAN

Manufacturer, Fabricant, Producent, Producător, Fabricante:

UK Manufacturer:

Kingfisher International Products Limited
3 Sheldon Square, London, W2 6PX
United Kingdom
www.kingfisher.com/products

EU Manufacturer:

Kingfisher International Products B.V.
Rapenburgerstraat 175E
1011 VM Amsterdam
The Netherlands
www.kingfisher.com/products

- | | | |
|-----------|--|---|
| EN | www.screwfix.com
www.screwfix.ie | To view instruction manuals online, visit
www.kingfisher.com/products |
| FR | www.bricodepot.fr | Pour consulter les manuels d'instructions en ligne,
rendez-vous sur le site www.kingfisher.com/products |
| ES | www.bricodepot.es | Para consultar los manuales de instrucciones en línea,
visite www.kingfisher.com/products |
| PT | www.bricodepot.pt | Para consultar manuais de instruções online, visite
www.kingfisher.com/products |