

TITAN

500W Tile Cutter

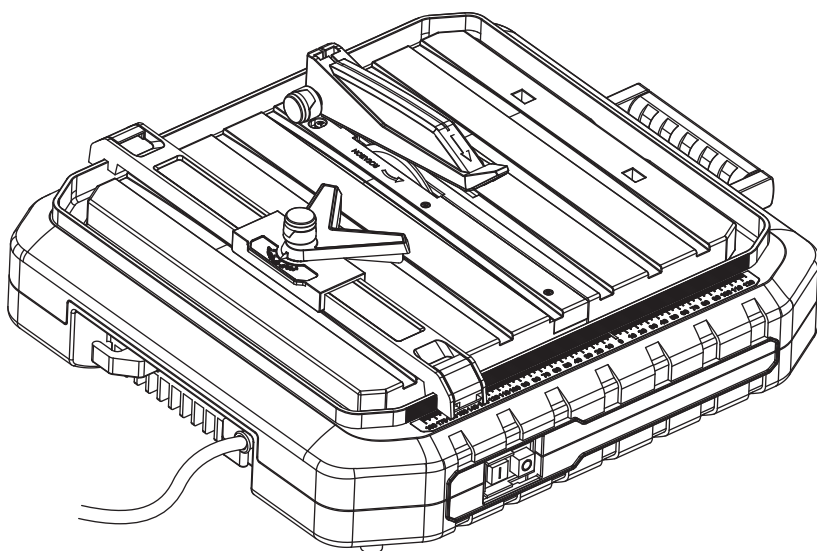

TTB903TCH

EAN: 5059340252629



WARNING! Read the instructions before using the product!

BX220IM

Let's get started...

These instructions are for your safety. Please read through them thoroughly before use and retain them for future reference.



Getting **started**... 02

Your product	03
Technical and legal information	05
Before you start	12



In more **detail**... 22

Product functions	23
Care and maintenance	27
Trouble shooting	33
Recycling and disposal	34
Guarantee	35
EC declaration of conformity	36

Your product

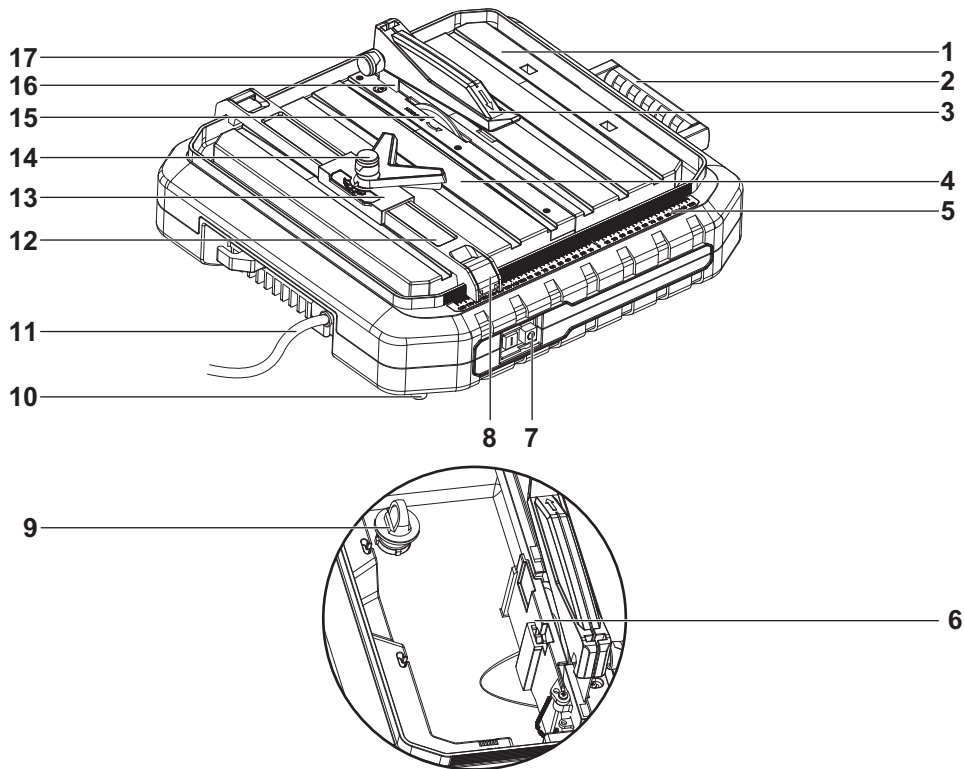

- | | |
|---|--|
| 1. 45° Vertical fence | 10. Base foot |
| 2. Transportation handle | 11. Plug cable |
| 3. Upper protective guard | 12. Parallel cutting guide |
| 4. Working table | 13. Mitre cutting guide |
| 5. Scale | 14. Locking knob
(for mitre cutting guide) |
| 6. Lower protective guard | 15. Cutting disc |
| 7. On/Off switch | 16. Metal bracket |
| 8. Locking knob
(for parallel cutting guide) | 17. Locking knob
(for upper protective guard) |
| 9. Water reservoir plug | |

Safety devices

Metal bracket

The metal bracket (16) prevents a workpiece being caught by the cutting disc (15) and being hurled at the operator.

The metal bracket must always be mounted during operation.

Upper protective guard

The upper protective guard (3) prevents accidental contact with the cutting disc (15) and stops workpiece parts and cooling water from being flung out.

The upper protective guard must always be mounted during the operation and can be lowered to the workpiece.

Lower protective guard

The lower protective guard (6) prevents accidental contact with the cutting disc (15) and stops workpiece parts and cooling water from being flung out.

The lower cutting disc cover must always be mounted during operation.

Technical specifications

General

> Input Voltage	: 220-240V~50Hz
> Power Input	: 500W
> No Load Speed	: 5200min ⁻¹
> Insulation Class	: Class I
> Diamond Disc Size	: ø115mmx2.1mmxø22.2mm
> Table Size	: 330x360mm
> Table Tilt Range	: 0°/45°
> Maximum Cutting Depth	: 20mm
> Net Weight	: 5.9kg

NOISE

A weighted sound pressure L_{pA}94dB(A)

A weighted sound pressure L_{WA}107dB(A)

Uncertainty.....3dB(A)

The sound intensity level for the operator may exceed 85dB(A) and sound protection measures are necessary.

Information:

- declared noise emission value(s) have been measured in accordance with a standard test method and may be used for comparing one tool with another;
- the declared noise emission value(s) may also be used in a preliminary assessment of exposure.

Warning:

- the noise emissions during actual use of the power tool can differ from the declared values depending on the ways in which the tool is used especially what kind of workpiece is processed; and
- it is necessary to identify safety measures to protect the operator that are based on an estimation of exposure in the actual conditions of use (taking account of all parts of the operating cycle such as the times when the tool is switched off and when it is running idle in addition to the trigger time).

Important note

Remove the mains plug from socket before carrying out any adjustment or servicing.

Ensure your mains supply voltage is the same as your tool rating plate voltage.

The following information applies to professional users only but is good practice for all users:

ADDITIONAL SAFETY WARNING FOR CONSTRUCTION DUST

The updated Control of Substances Hazardous to Health Regulations 1st October 2012 now also targets to reduce the risks associated with silica, wood and gypsum dusts.

Construction workers are one of the at-risk groups within this because of the dust that they breathe: silica dust is not just a nuisance; it is a real risk to your lungs! Silica is a natural mineral present in large amounts in things like sand, sandstone and granite. It is also commonly found in many construction materials such as concrete and mortar. The silica is broken into very fine dust (also known

as Respirable Crystalline Silica or RCS) during many common tasks such as cutting, drilling and grinding Breathing in very fine particles of crystalline silica can lead to the development of:

Lung cancer Silicosis Chronic Obstructive Pulmonary Disorder (Chronic obstructive pulmonary disease (COPD) And breathing in fine particles of wood dust can lead to the development of Asthma The risk of lung disease is linked to people who regularly breathe construction dust over a period of time, not on the odd occasion. To protect the lung, the COSHH Regulations sets a limit on the amount of these dusts that you can breathe (called a Workplace Exposure Limit or WEL) when averaged over a normal working day. These limits are not a large amount of dust: when compared to a penny it is tiny – like a small pinch of salt:

This limit is the legal maximum; the most you can breathe after the right controls have been used.

How to reduce the amount of dust?

1. Reduce the amount of cutting by using the best sizes of building products.
2. Use a less powerful tool e.g. a block cutter instead of angle grinder.
3. Using a different method of work altogether – e.g. using a nail gun to direct fasten cable trays instead of drilling holes first.

Please always work with approved safety equipment, such as those dust masks that specially designed to filter out microscopic particles and use the dust extraction facility at all time.

For more information please see the HSE website:

<http://www.hse.gov.uk/construction> or <http://www.hse.gov.uk/pubns/cis69.pdf>



Warning: Some dust particles created by power sanding, sawing, grinding, drill and other construction jobs contain chemicals known to cause cancer, birth defects or other reproductive harm. Some examples of these chemicals are:

- Lead from lead-based paints.
- Crystalline silica from bricks and cement and other masonry products.
- Arsenic and chromium from chemically treated timber.

Your risk from these exposures varies, depending upon how often you do this type of work. To reduce your exposure to these chemicals:

- Work in a well-ventilated area.
- Work with approved safety equipment, such as those dust masks that are specially designed to filter microscopic particles.

VIBRATION

The European Physical Agents (Vibration) Directive has been brought in to help reduce hand arm vibration syndrome injuries to power tool users. The directive requires power tool manufacturers and suppliers to provide indicative vibration test results to enable users to make informed decisions as to the period of time

a power tool can be used safely on a daily basis and the choice of tool.

SEE TECHNICAL SPECIFICATIONS IN THE INSTRUCTION MANUAL FOR THE VIBRATION LEVELS OF YOUR TOOL.

The declared vibration emission value should be used as a minimum level and should be used with the current guidance on vibration.

Calculating the actual period of the actual period off use can be difficult and the HSE website has further information.

The declared vibration emission been measured in accordance with a standardised test stated above and may be used to compare one tool with another tool.

The declared vibration emission value may also be used in a preliminary assessment of exposure.

 **Warning:** The vibration emission value during actual use of the power tool can differ from the declared value depending on the ways in which the tool is used dependant on the following examples and other variations on how the tool is used:

How the tool is used and the materials being cut or drilled.

The tool being in good condition and well maintained.

The use the correct accessory for the tool and ensuring it is sharp and in good condition.

The tightness of the grip on the handles.

And the tool is being used as intended by its design and these instructions.

While working with this power tool, hand/arm vibrations occur. Adopt the correct working practices in order to reduce the exposure to vibration. This tool may cause hand-arm vibration syndrome if its use is not adequately managed.

 **Warning:** Identify safety measures to protect the operator that are based on an estimation of exposure in the actual conditions of use (taking account of all parts of the operating cycle such as the times when the tool is switched off and when it is running idle in addition to the trigger time). Note The use of other tools will reduce the users' total working period on this tool.

Helping to minimise your vibration exposure risk. ALWAYS use sharp chisels, drills and blades.

Maintain this tool in accordance with these instructions and keep well lubricated (where appropriate).

Avoid using tools in temperatures of 10°C or less. Plan your work schedule to spread any high vibration tool use across a number of days.

Health surveillance

All employees should be part of an employer's health surveillance scheme to help identify any vibration related diseases at an early stage, prevent disease progression and help employees stay in work.

Symbols

On the product, the rating label and within these instructions you will find among others the following symbols and abbreviations.

Familiarise yourself with them to reduce hazards like personal injuries and damage to property.

V~	Volt	Hz	Hertz
W	Input power	kg	Kilogram
min ⁻¹	Per minute	dB(A)	Decibel (A-rated)
yyWxx	Manufacturing date code; year of manufacturing (20yy) and week of manufacturing (Wxx);		



Caution / Warning.



Wear hearing protection.



Read the instruction manual.



Wear eye protection.



Wear gloves.



Wear respiratory protection.



Caution, risk of cutting.



Use only non fragmented discs.



Switch the product off and disconnect it from the power supply before assembly, cleaning, adjustments, maintenance, storage and transportation.



The product complies with the applicable European directives and an evaluation method of conformity for these directives was done.



UK Conformity Assessed.



Protective earth.



Degree of protection against water ingress.



WEEE symbol. Waste electrical products should not be disposed of with household waste. Please recycle where facilities exist.



Check with your Local Authority or local store for recycling advice.

TTB903TCH Designation of the tool (**TTB** - TITAN, **TCH** - Tile cutter, **903** - Version number)

Safety warnings

GENERAL POWER TOOL SAFETY WARNINGS

 **Warning! Read all safety warnings, instructions, illustrations and specifications provided with this power tool.** Failure to follow all instructions listed below may result in electric shock, fire and/or serious injury.

Keep all safety instructions and information for future reference! The term "power tool" in the warnings refers to your mains-operated (corded) power tool or battery-operated (cordless) power tool.

1. Work area safety

- a) **Keep work area clean and well lit.** Cluttered or dark areas invite accidents.
- b) **Do not operate power tools in explosive atmospheres, such as in the presence of flammable liquids, gases or dust.** Power tools create sparks which may ignite the dust or fumes.
- c) **Keep children and bystanders away while operating a power tool.** Distractions can cause you to lose control.

2. Electrical safety

- a) **Power tool plugs must match the outlet. Never modify the plug in any way. Do not use any adapter plugs with earthed (grounded) power tools.** Unmodified plugs and matching outlets will reduce risk of electric shock.
- b) **Avoid body contact with earthed or grounded surfaces, such as pipes, radiators, ranges and refrigerators.** There is an increased risk of electric shock if your body is earthed or grounded.
- c) **Do not expose power tools to rain or wet conditions.** Water entering a power tool will increase the risk of electric shock.
- d) **Do not abuse the cord. Never use the cord for carrying, pulling or unplugging the power tool. Keep cord away from heat, oil, sharp edges or moving parts.** Damaged or entangled cords increase the risk of electric shock.
- e) **When operating a power tool outdoors, use an extension cord suitable for outdoor use.** Use of a cord suitable for outdoor use reduces the risk of electric shock.
- f) **If operating a power tool in a damp location is unavoidable, use a residual current device (RCD) protected supply.** Use of an RCD reduces the risk of electric shock.

3. Personal safety

- a) **Stay alert, watch what you are doing and use common sense when operating a power tool. Do not use a power tool while you are tired or under the influence of drugs, alcohol or medication.** A moment of inattention while operating power tools may result in serious personal injury.
- b) **Use personal protective equipment. Always wear eye protection.** Protective equipment such as dust mask, non-skid safety shoes, hard hat, or hearing protection used for appropriate conditions will reduce personal injuries.
- c) **Prevent unintentional starting. Ensure the switch is in the off-position before connecting to power source and/or battery pack, picking up or carrying the tool.** Carrying power tools with your finger on the switch or energising power tools that have the switch on invites accidents.
- d) **Remove any adjusting key or wrench before turning the power tool on.** A wrench or a key left attached to a rotating part of the device may result in personal injury.

- e) **Do not overreach. Keep proper footing and balance at all times.** This enables better control of the power tool in unexpected situations.
- f) **Dress properly. Do not wear loose clothing or jewellery. Keep your hair and clothing away from moving parts.** Loose clothes, jewellery or long hair can be caught in moving parts.
- g) **If devices are provided for the connection of dust extraction and collection facilities, ensure these are connected and properly used.** Use of dust extraction can reduce dust-related hazards.
- h) **Do not let familiarity gained from frequent use of tools allow you to become complacent and ignore tool safety principles.** A careless action can cause severe injury within a fraction of a second.

4. Power tool use and care

- a) **Do not force the power tool. Use the correct power tool for your application.** The correct power tool will do the job better and safer at the rate for which it was designed.
- b) **Do not use the power tool if the switch does not turn it on and off.** Any power tool that cannot be controlled with the switch is dangerous and must be repaired.
- c) **Disconnect the plug from the power source and/or remove the battery pack, if detachable, from the power tool before making any adjustments, changing accessories, or storing power tools.** Such preventive safety measures reduce the risk of starting the power tool accidentally.
- d) **Store idle power tools out of the reach of children. Do not allow persons unfamiliar with the power tool or these instructions to operate the power tool.** Power tools are dangerous in the hands of untrained users.
- e) **Maintain power tools and accessories with care. Check for misalignment or binding of moving parts, breakage of parts and any other condition that may affect the power tool's operation. If damaged, have the power tool repaired before use.** Many accidents are caused by poorly maintained power tools.
- f) **Keep cutting tools sharp and clean.** Properly maintained cutting tools with sharp cutting edges are less likely to bind and are easier to control.
- g) **Use the power tool, accessories, tool bits etc. in accordance with these instructions. Take into account the working conditions and the work to be performed.** Use of the power tool for operations different from those intended could result in a hazardous situation.
- h) **Keep handles and grasping surfaces dry, clean and free from oil and grease.** Slippery handles and grasping surfaces do not allow for safe handling and control of the tool in unexpected situations.

5. Service

- a) **Have your power tool serviced by a qualified repair person using only identical replacement parts.** This will ensure that the safety of the power tool is maintained.

HEALTH ADVICE



Warning! When drilling, sanding, sawing or grinding, dust particles will be produced. In some instances, depending on the materials you are working with, this dust can be particularly harmful to you (e.g. lead from old gloss paint). You are advised to consider the risks associated with the materials you are working with and to reduce the risk of exposure. You should:

- Work in a well-ventilated area.
- Work with approved safety equipment, such as those dust masks that are specially designed to filter microscopic particles.

ADDITIONAL SAFETY INSTRUCTIONS FOR YOUR TOOLS

- > Do not use diamond discs which are damaged or deformed.
- > Replace table insert when worn.
- > Use only diamond discs recommended by the manufacturer.
- > Take care that the selection of the diamond discs is suitable for the material to be cut.
- > Wear suitable personal protective equipment when necessary, this could include hearing protection to reduce the risk of induced hearing loss, respiratory protection to reduce the risk of inhalation of harmful dust, wear gloves when handling diamond discs and rough material.
- > Never use blades on this machine.
- > Use only diamond discs for which the maximum possible speed is not less than the maximum spindle speed of the tool and the material to be cut.
- > Faults in the machine, including guards or diamond discs, should be reported as soon as they are discovered. Never use the machine without the guard in position.
- > Maximum size of working piece should be 1m².
- > This tile cutter should be used with limitations on ambient conditions (between 15°C and 30°C).
- > The machine must be supplied through a residual current device (RCD).

Wear goggles

Wear ear defenders

Wear a breathing mask

Unpack

- > Unpack all parts and lay them on a flat, stable surface.
- > Remove all packing materials and shipping devices if applicable.
- > Make sure the delivery contents are complete and free of any damage. If you find that parts are missing or show damage do not use the product but contact your dealer. Using an incomplete or damaged product represents a hazard to people and property.
- > Ensure that you have all the accessories and tools needed for assembly and operation. This also includes suitable personal protective equipment.

You will need

(items not supplied)

- > Phillips screwdriver

(items supplied)

- > Straight disc spanner (1 pc)
- > Angle disc spanner (1 pc)



WARNING: Risk of injury!

Always pull out the mains plug (disconnect the product from its power supply) before commencing work on the product.

Fitting the base foot

- > Insert the four base feet (10) into the openings (18) on the underside of the product.

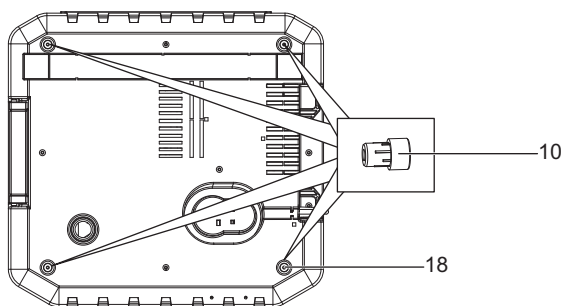

Fig. 1

Fitting the cutting disc



WARNING: Product damage!

Be sure to observe the rotational direction of the cutting disc when fitting! Be sure to observe the free-wheeling of the cutting disc when fitting!



NOTE: When fitting make sure that the cutting disc is placed correctly on the inner flange. The inner flange can be moved freely on the motor shaft and has a section for holding the internal hole of the cutting disc. The hole of the outer flange is not round and is used for the interlocking connection with the motor shaft.

- > Unplug the tile cutter from the mains supply.
- > Raise the 45° Vertical fence (1) approx. 45° and remove.

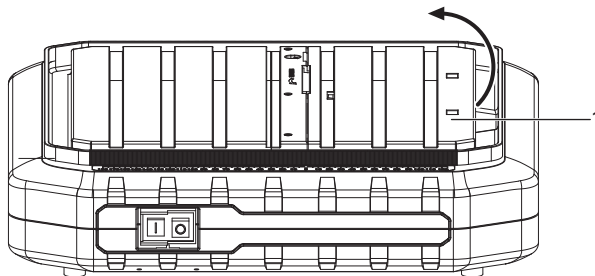

Fig. 2

- > Loosen screw (19) and pull off lower protective guard (6).

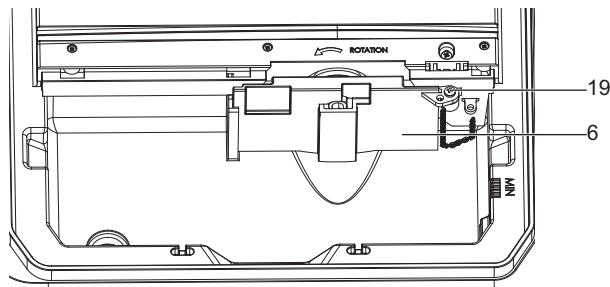

Fig. 3

- > Attach the angle disc spanner (20) to the arbor nut (21).
- > Lock motor shaft (22) to prevent turning using straight disc spanner (23) (supplied).
- > Turn the arbor nut (21) anti-clockwise.
- > Remove the arbor nut (21) and outer flange (24).

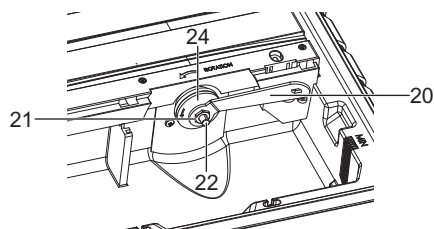

Fig. 4

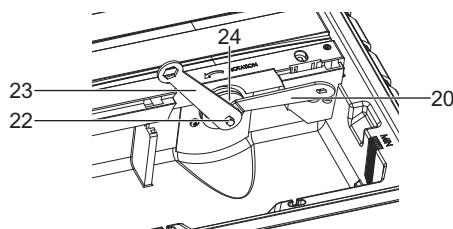

Fig. 5

- > Place cutting disc (15) on inner flange (25).
- > Attach the outer flange (24).
- > Screw arbor nut (21) onto motor shaft (22) clockwise.
- > Attach the angle disc spanner (20) to the arbor nut (21).
- > Lock motor shaft (22) to prevent turning using straight disc spanner (23).
- > Tighten arbor nut (21) clockwise using angle disc spanner (20).
- > Re-attach the lower protective guard (6) and tighten screw (19).
- > Replace the 45° vertical fence (1).

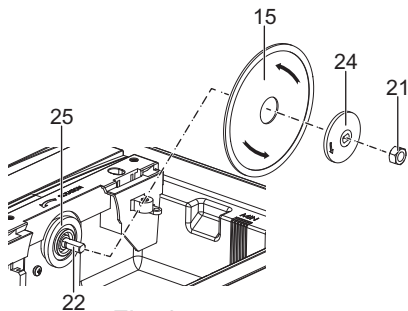

Fig. 6

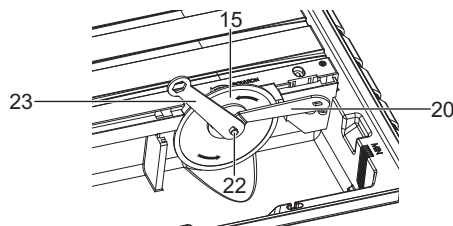

Fig. 7

Assemble/adjust metal bracket



WARNING: Product damage!

The metal bracket must always be aligned parallel to the cutting disc.

- > Unplug the tile cutter from the mains supply.
- > Raise the 45° Vertical fence (1) approx. 45° and remove. (Refet to Fig. 2)
- > Loosen screw (19) and pull off lower protective guard (6). (Refet to Fig. 3)
- > Remove the screw (26) and washer (27) from the metal bracket (16).

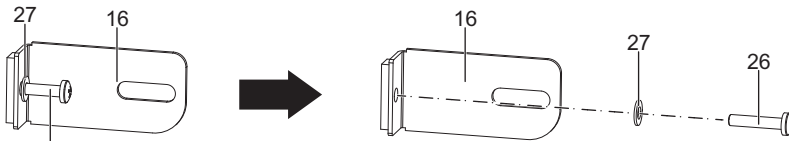

Fig. 8

- > Push the metal bracket (16) through gap in the housing from below. Ensuring the L section is facing forwards.
- > Attach the metal bracket (16) to the screw (26) and washer (27).
- > Gently tighten the screw (26) with a Phillips screwdriver (not supplied).
- > Align metal bracket (16) with the cutting disc (15).
- > Tighten the screw (26) with a Phillips screwdriver (not supplied).
- > Replace the 45° vertical fence (1).

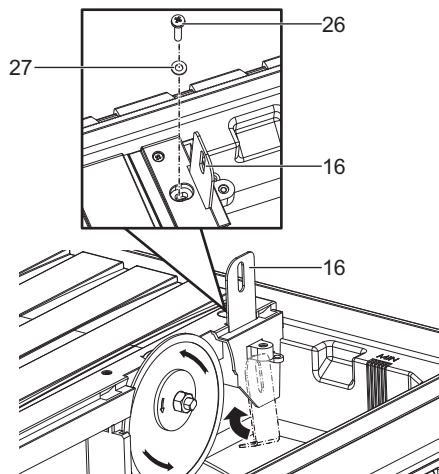

Fig. 9

Mounting the upper protective guard to the metal bracket



WARNING: Product damage!

Do not over-tighten socket head bolt (28) and locking knob (17). The upper protective guard (3) must be free to rise and fall as the workpiece is pushed towards the cutting disc.

- > Unplug the tile cutter from the mains supply.
- > Push the upper protective guard (3) onto the metal bracket (16).
- > Push socket head bolt (28) through upper protective guard (3) and metal bracket (16).
- > Push the flat washer (29) onto socket head bolt (28).
- > Screw and tighten locking knob (17) onto socket head bolt (28).
- > Cover the cutting disc with the upper protective guard (3).
- > Ensure that upper protective guard (3) can move freely and that it cannot touch the cutting disc.

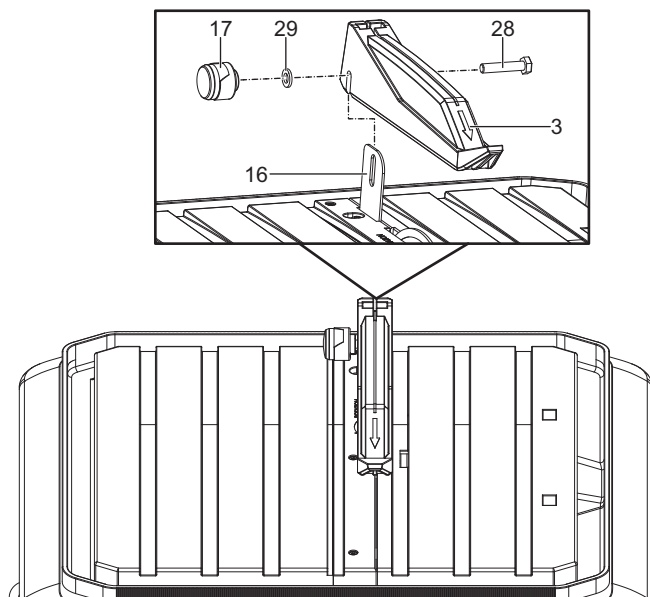

Fig. 10

Mounting the parallel cutting guide

- > Unplug the tile cutter from the mains supply.
- > Open the locking knobs (8) for parallel cutting guide.
- > Position the parallel cutting guide (12) on the rail (30).
- > Push down the locking knobs (8).

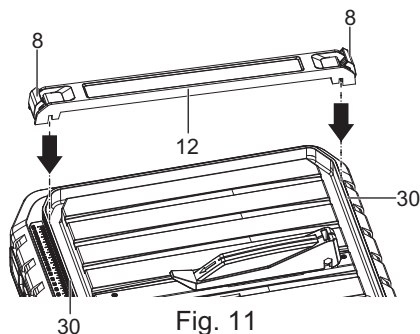

Fig. 11

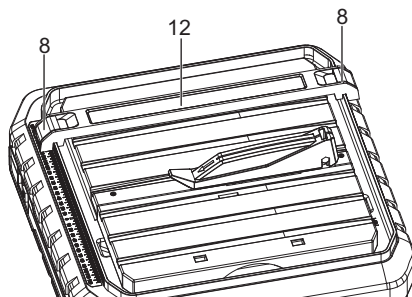

Fig. 12

Adjusting the parallel cutting guide

- > Open the locking knobs (8) for parallel cutting guide.
- > Push the parallel cutting guide (12) to the desired distance.
- > Push down the locking knobs (8).

Mounting/setting the mitre cutting guide



NOTE: The mitre cutting guide can be set to a desired angle (0°~45°). The mitre cutting guide can only be used when the parallel cutting guide is mounted.

- > Place mitre cutting guide (13) on parallel cutting guide (12).
- > Loosen locking knob (14).
- > Set mitre cutting guide (13) at desired angle.
- > Tighten locking knob (14).

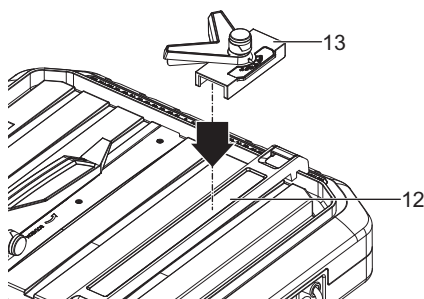

Fig. 13

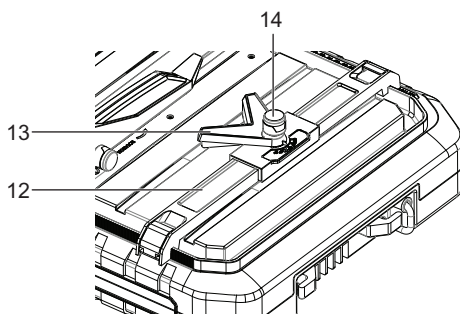

Fig. 14

Setting product for bevel cuts



NOTE: The 45° vertical fence can be set to a desired angle (0°, 45°).

- > Raise the 45° vertical fence (1) approx. 45°.
- > Fold out the holder (31) and position in the locator (32).
- > Ensure that the 45° vertical fence (1) is correctly secured before working.

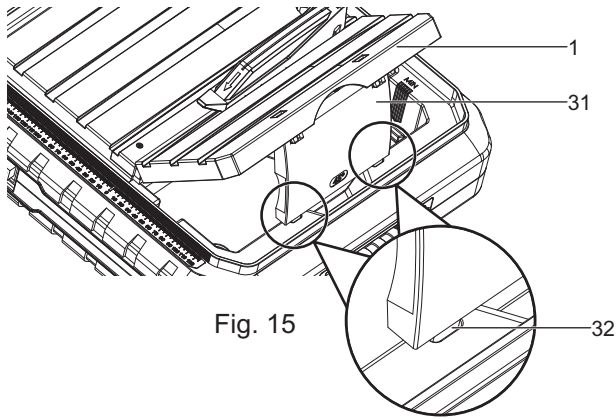

Fig. 15

Filling the product with water



NOTE: Product damage!

Fill the product with water only until water can drain from the opening in the plug.

During use the water level must never drop below the MIN marking (33).



NOTE: Product damage!

Fill the product only with clear water. Never use chemicals or cleaning agents. This can cause irreparable damage to the product.

Drain cooling water out of the product on completion of the work (Refer to "Replacing the cooling water" section).

- > Unplug the tile cutter from the mains supply.
- > Raise the 45° vertical fence approx. 45° and remove.
- > Insert the water reservoir plug (9) into the drain opening.
- > Fill the tank with water only until water can drain from the opening in the plug.
- > When you have finished cutting, remove the water reservoir plug (9) inside the tank to drain the water.

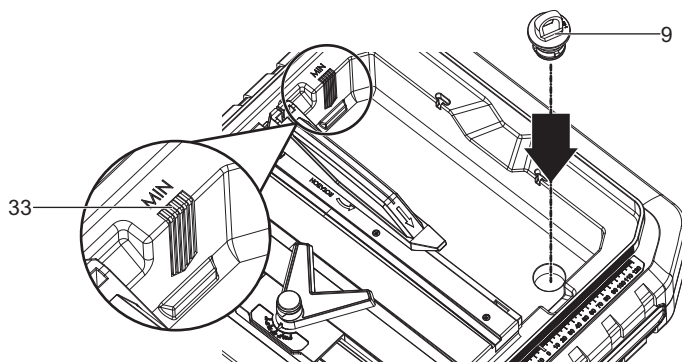

Fig. 16

Check before starting!



Warning: Risk of injury!

The product must be mounted in a stable position, i.e. on a workbench, a universal subframe or similar.



Warning: Risk of injury!

As soon as a malfunction occurs, push the red 0-Button on the On/Off Switch and pull out the mains plug.



Warning: Risk of injury!

The defect may be put into operation only if no defects or errors are found. Ensure that any defective parts are replaced before the product is used again.

Check the safe condition of the product before plugging the power cable:

- > Check whether there are any visible defects or faults.
- > Check whether all parts of the product are firmly attached.
- > Check that the safety devices are in faultless condition.
- > Check that the cutting disc can run freely.
- > Check there is sufficient cooling water in the product.

Connection to the electrical supply

Check the safe condition of the product before plugging the power cable:

- > Before switching on, make sure that the voltage of the mains supply is the same as indicated on the rating plate. This product is designed to operate on 220-240V~50Hz. Connecting it to any other power source may cause damage.
- > This appliance must be earthed. If in doubt, please consult a qualified electrician. The mains supply shall be fed via a 10A fuse min.
- > This machine must be supplied through a residual current device (RCD).

In more detail...



Product functions	23
Care and maintenance	27
Trouble shooting	33
Recycling and disposal	34
Guarantee	35
EC declaration of conformity	36



WARNING! Before switching the tile cutter on, make sure that you have read and understood all of the safety instructions. Make sure also that the machine has been correctly assembled and adjusted. Make sure that the mains is disconnected from the supply when the tile cutter is not being used, or adjustments are being made.



WARNING! Risk of injury!

Maintain an adequate distance from the cutting disc when cutting.



WARNING! Risk of injury!

Do not reach into the working range of the spinning cutting disc while the product is operating.



NOTE: Product damage!

Carefully check the workpiece to be machined. Foreign bodies such as nails, screws or similar can seriously damage the product.



NOTE: Product damage!

The product is not suitable for cutting materials such as marble, fine stoneware and granite. Tile floor made up of these materials must not be cut.



NOTE: Product damage!

Wait until the cutting disc has reached its maximum speed before commencing work.



NOTE: Product damage!

Before commencing work, check there is sufficient cooling water in the product.



NOTE: In the case of complex cuts (mitre or jolly) we recommend making a test cut beforehand.



WARNING! This machine must be supplied through a residual current device (RCD).



WARNING: The disc will continue to rotate for a few seconds after the machine has been switched off. Wait for the disc to stop before removing the workpiece, or making any adjustments.

Stop the machine immediately if there is undue vibration or some other fault. If this situation continues, check the machine to find the origin of the fault.

Intended use

This tile cutter shall be used only to cut tiles to a required size or shape. It shall not be used to cut inflammable, explosive or toxic materials. This product should not be used on other materials or those harmful to health.

Other uses for the machine will lead to the damage of the machine and a series of dangers to the operator. This appliance is for private and household use, not for professional or industrial ones. Only identical accessories as the ones provided with the tile cutter are authorised. Never use the appliance in the rain or other wet conditions.

For safety reasons it is essential to read the entire instruction manual before first operation and to observe all the instructions therein.

On/Off Switch



WARNING: Risk of injury!

Always pull out the mains plug in case of power failure (disconnect the product from its power supply).

Switching on:

- > The product can be switched on by pressing the green I-Button on the On/Off Switch (7).
- > Wait until the cutting disc has reached its maximum speed before commencing work.

Switching off:

- > The product can be switched off by pressing the red 0-Button on the On/Off Switch (7).

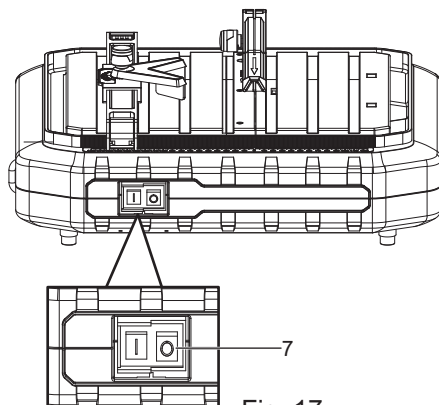

Fig. 17

Making a straight cut

Adjust the parallel cutting guide (12) to the desired width. Use the locking knob to loosen or adjust the guide. Position the tile firmly against the parallel cutting guide (12) and pass through the cutting disc in a smooth action. Hold the edges of the tile and press down firmly to prevent the tile lifting during the cut.

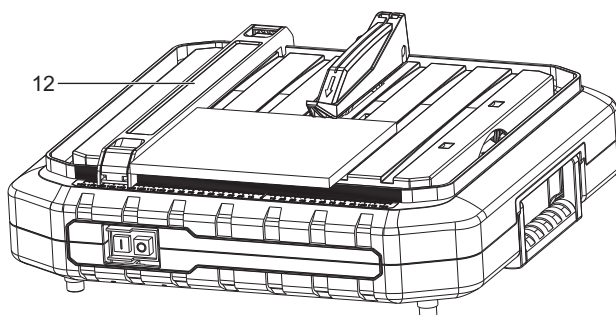

Fig. 18

Making a mitre or diagonal cut

Follow the same procedure for a straight cut but use the mitre cutting guide (13) in conjunction with the parallel cutting guide (12). The mitre cutting guide (13) simply clips onto the parallel cutting guide (12).

Make sure that the tile is held firmly in the guide before making the cut.

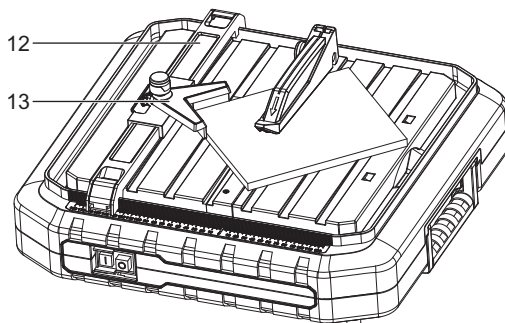

Fig. 19

Cutting an angle or bevel

Use the 45° vertical fence (1) if you wish to cut an angle or bevel on the tile edge. Raise the 45° vertical fence (1) approx. 45°.

Fold out the holder and position in the locators. Then make the cut as before.

Internal or external bevel cuts can be made by turning the tile face up or down (internal – eg. wall corner; external – eg. window reveal).

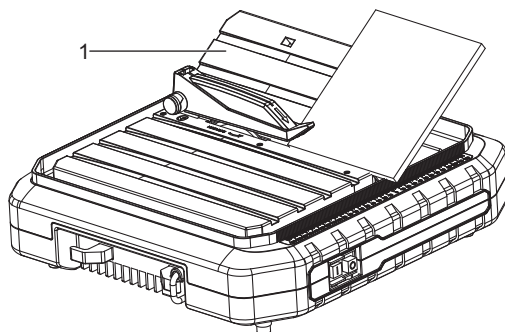

Fig. 20

The golden rules for care



WARNING! Always switch the product off, disconnect it from the power supply and let the product cool down before performing inspection, maintenance and cleaning work!

- > Keep the product clean. Remove debris from it after each use and before storage.
- > Regular and proper cleaning will help ensure safe use and prolong the life of the product.
- > Inspect the product before each use for worn and damaged parts. Do not operate it if you find broken and worn parts.



WARNING! Only perform repairs and maintenance work according to these instructions! All further works must be performed by a qualified specialist!

General cleaning



DANGER: Risk of electric shock!

Never spray the product with water or expose it to water. Never use detergents or solvents for cleaning. This can cause irreparable damage to the product. The plastic parts can be eaten away by chemicals.

Careful handling and regular cleaning ensure that the product remains functional and efficient for a long time.

- > Remove any dirt using a brush.
- > Wipe down the product with a slightly damp cloth.
- > Keep ventilation slots clean and free of dust.

Replacing the cooling water



DANGER: Risk of injury!

Dirt deposits can have sharp edges. Use clear water to remove dirt deposits.

- > Raise the 45° vertical fence (1) approx. 45° and remove.
- > Place a suitable collector below the product's drain opening.
- > Remove water reservoir plug (9) and drain off all the dirty cooling water.
- > Filling the product with water (Refer to "Filling the product with water" section on Page. 19-20).

Replacing the cutting disc



WARNING: Risk of injury!

Never use segmented cutting discs.



WARNING: Risk of injury!

Always wear protective gloves when replacing the cutting disc.



WARNING: Risk of injury!

The metal bracket must always be aligned parallel to the cutting disc.

Removing the cutting disc:

- > Raise the vertical fence (1) approx. 45° and remove.

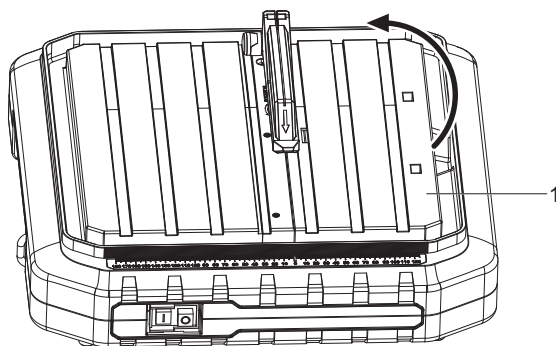

Fig. 21

- > Loosen screw (19) and pull off lower protective guard (6).

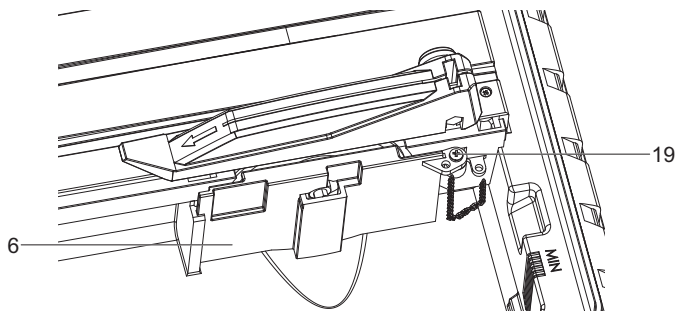

Fig. 22

- > Attach the anngle disc spanner (20) (supplied) to the arbor nut (21).
- > Lock motor shaft (22) to prevent turning using straight disc spanner (23) (supplied).
- > Turn the arbor nut (21) anti-clockwise.
- > Remove the arbor nut (21), outer flange (24) and cutting disc (15).
- > Thoroughly clean outer flange, inner flange and motor shaft.

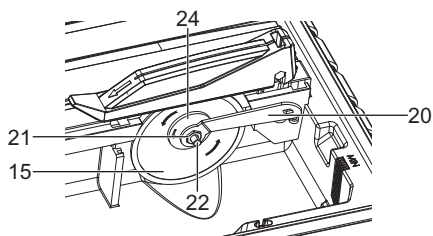

Fig. 23

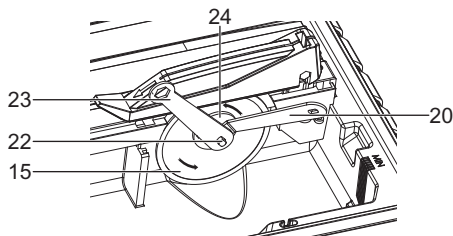

Fig. 24

Fitting the cutting disc: (Refer to "Fitting the cutting disc" section on Page. 13-14)

Power cord

- > If the power cord is damaged, it must be replaced by the manufacturer, its service agent or similarly qualified person in order to avoid a safety hazard.

Plug replacement

If you need to replace the fitted plug then follow the instructions below.

Important

The wires in the mains lead are coloured in accordance with the following code:

Green & yellow - Earth

Blue - Neutral

Brown - Live

As the colours of the wires in the mains lead of this appliance may not correspond with the coloured markings identifying the terminals in your plug, proceed as follows. The wire which is coloured **green & yellow** must be connected to the terminal which is marked with **E** or \perp .

The wire which is coloured **blue** must be connected to the terminal which is marked with **N**. The wire, which is coloured brown, must be connected to the terminal, which is marked with the letter **L**.

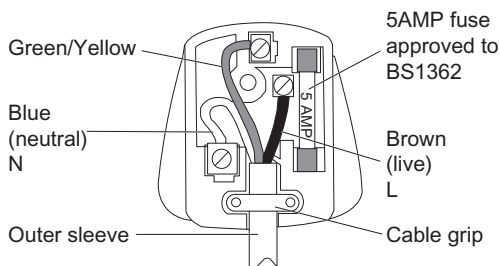

Fig. 25



Warning: Never connect live or neutral wires to the earth terminal of the plug. Only fit an approved 5 Amp BS1363/A plug and the correct rated fuse.



NOTE: If a moulded plug is fitted and has to be removed take great care in disposing of the plug and severed cable, it must be destroyed to prevent engaging into a socket.

If the supply cord is damaged it must be replaced by a service agent or a similarly qualified person in order to avoid hazard.

Repair

- > This product does not contain any parts that can be repaired by the consumer. Contact a qualified specialist to have it checked and repaired.
- > Apart from diamond discs there are no other user serviceable parts inside this tile cutter. Refer to qualified service personnel if internal maintenance is required. Any worn, or damaged parts should be replaced immediately by qualified personnel. Keep discs in good condition. Poor condition or worn discs can increase the noise level emitted.
- > If the supply cable is damaged, it should be replaced by the same type of cable as the one provided and recommended by the manufacturer (H05 VV-F 3G0.75 mm²). The supply cord of the tool and any extension cord used should be checked frequently for damage.
- > If damaged, have the cordset replaced by an authorised service facility. Replace the extension cord if necessary.

Storage



Warning: Risk of injury!

Store the product so that it cannot be switched on by unauthorized persons.

Ensure that nobody can injure themselves on the product while it is stationary.



NOTE: Product damage!

Do not store the product unprotected in a humid environment.

- > Store the product and its accessories in a dry, frost-free place.
- > Always store the product in a place that is inaccessible to children. The ideal storage temperature is between 10 and 30°C.

- > We recommend using the original package for storage or covering the product with a suitable cloth to protect it against dust.

Transport

- > Dismantle any components that protrude from the product.
- > Use the original packaging to ship whenever possible.
- > Protect the product from any heavy impact or strong vibrations which may occur during transportation in vehicles.
- > Secure the product to prevent it from slipping or falling over.

Trouble shooting

Suspected malfunctions are often due to causes that the users can fix themselves. Therefore check the product using this section. In most cases the problem can be solved quickly.



WARNING! Only perform the steps described within these instructions! All further inspection, maintenance and repair work must be performed by an authorised service centre or a similarly qualified specialist if you cannot solve the problem yourself!

Problem	Possible cause	Solution
1. Motor not running	1. No mains voltage.	1. Check cable, plug, socket and fuse.
2. Motor runs, cutting disc remains still when subject to load.	2. Flange nut loose.	2. Check the flange is seated correctly and tighten if necessary.
3. Cutting disc runs irregularly/vibrates	3.1 Cutting disc warped. 3.2 Cutting disc fitted incorrectly.	3.1 Replacing the cutting disc. 3.2 Fit the cutting disc correctly.
4. Cutting disc is discoloured.	4.1 Insufficient cooling water. 4.2 Lateral friction caused by cut runout.	4.1 Fill the product with water. 4.2 Guide workpiece through cutting disc more slowly.

Recycling and disposal



- > Waste electrical products should not be disposed of with household waste. Please recycle where facilities exist. Check with your Local Authority or local store for recycling advice.

Guarantee

We take special care to select high quality materials and use manufacturing techniques that allow us to create products incorporating design and durability. This product **TITAN 500W Tile Cutter** has a manufacturer's guarantee of 2 years against manufacturing defects, from the date of purchase (if bought in store) or date of delivery (if bought online), at no additional cost for normal (non-professional or commercial) household use.

To make a claim under this guarantee, you must present your proof of purchase (such as a sales receipt, purchase invoice or other evidence admissible under applicable law), please keep your proof of purchase in a safe place. For this guarantee to apply, the product you purchased must be new, it will not apply to second hand or display products. Unless stated otherwise by applicable law, any replacement product issued under this guarantee will only be guaranteed until expiry of the original guarantee period.

This guarantee covers product failures and malfunctions provided the product was used for the purpose for which it is intended and subject to installation, cleaning, care and maintenance in accordance with the information contained in these terms and conditions, in the user manual and standard practice, provided that standard practice does not conflict with the user manual.

This guarantee does not cover defects and damage caused by normal wear and tear or damage that could be the result of improper use, faulty installation or assembly, neglect, accident, misuse, or modification of the product. Unless stated otherwise by applicable law, this guarantee will not cover, in any case, ancillary costs (shipping, movement, costs of uninstalling and reinstalling, labour etc), or direct and indirect damage.

This guarantee does not cover defects and damage caused by or resulting from:

Normal wear and tear

Overload, misuse or neglect

Repairs attempted by anyone other than an authorised agent

Cosmetic damage

Damage caused by foreign objects, substances or accidents

Accidental damage or modification

Failure to follow manufacturer's guidelines

Loss of use of the goods

If the product is defective, we will, within a reasonable time, repair or replace it.

Rights under this guarantee are enforceable in the country in which you purchased this product. Guarantee related queries should be addressed to the store you purchased this product from.

The guarantee is in addition to and does not affect your statutory rights.

EC declaration of conformity



(EN) EU DECLARATION OF CONFORMITY
 (FR) DÉCLARATION UE DE CONFORMITÉ
 (PL) DEKLARACJA ZGODNOŚCI UE
 (RO) DECLARAȚIA DE CONFORMITATE UE
 (ES) DECLARACIÓN UE DE CONFORMIDAD
 (PT) DECLARAÇÃO DE CONFORMIDADE UE

Product/ Produit/ Produkt/ Produsul/ Producto/ Produto

- 500W Tile Cutter / Coupe-carreaux 500W / Przecinarka do płytek 500 W / 500W Mașină de tăiat plăci ceramice / Cortadora de azulejos 500 W / Cortador de azulejos 500 W
- TTB903TCH
- Serial number: from 000001 to 999999

Name and address of the manufacturer or his authorised representative:

Nom et adresse du fabricant ou de son mandataire:

Nazwa i adres producenta lub jego upoważnionego przedstawiciela:

Denumirea și adresa producătorului sau a reprezentantului său autorizat:

Nombre y dirección del fabricante o de su representante autorizado:

Nome e endereço do fabricante ou do respetivo mandatário:

Kingfisher International Products B.V.,
 Rapenburgerstraat 175E,
 1011 VM Amsterdam,
 The Netherlands

This declaration of conformity is issued under the sole responsibility of the manufacturer.

La présente déclaration de conformité est établie sous la seule responsabilité du fabricant.

Niniejsza deklaracja zgodności wydana zostaje na wyłączną odpowiedzialność producenta.

Prezenta declarație de conformitate este emisă pe răspunderea exclusivă a producătorului.

La presente declaración de conformidad se expide bajo la exclusiva responsabilidad del fabricante.

A presente declaração de conformidade é emitida sob a exclusiva responsabilidade do fabricante.

Object of the declaration/Objet de la declaration/Przedmiot deklaracji/Obiectul declarației/Objeto de la declaración/
 Objeto da declaração

Product/Produit/Produkt/Produsul/Producto/ Produto

Model/Modèle/Model/
 Modelul/Modelo/Modelo

EAN

500W Tile Cutter
 Coupe-carreaux 500W
 Przecinarka do płytek 500 W
 500W Mașină de tăiat plăci ceramice
 Cortadora de azulejos 500 W
 Cortador de azulejos 500 W

TTB903TCH

5059340252629
 5059340175768

The object of the declaration described above is in conformity with the relevant Union harmonisation legislation:

L'objet de la déclaration décrit ci-dessus est conforme à la législation d'harmonisation de l'Union applicable:

Wymieniony powyżej przedmiot niniejszej deklaracji jest zgodny z odpowiednimi wymaganiami unijnego prawodawstwa harmonizacyjnego:

Obiectul declarației descris mai sus este în conformitate cu legislația relevantă de armonizare a Uniunii:

El objeto de la declaración descrita anteriormente es conforme con la legislación de armonización pertinente de la Unión:

O objeto da declaração acima descrito está em conformidade com a legislação de harmonização da União aplicável:

2006/42/EC as amended Machinery Directive

2014/30/EU as amended Directive Electromagnetic compatibility

2011/65/EU as amended Directive Restriction of the use of certain hazardous substances in electrical and electronic equipment

2006/42/CE en tant que directive modifiée sur les machines

2014/30 / UE telle que modifiée Directive Compatibilité électromagnétique

Directive 2011/65 / UE telle que modifiée Limitation de l'utilisation de certaines substances dangereuses dans les équipements électriques et électroniques

2006/42/WE w zmienionej dyrektywie maszynowej

2014/30 / UE ze zmianami Dyrektywa Kompatybilność elektromagnetyczna

2011/65 / UE ze zmianami Dyrektywa Ograniczenie stosowania niektórych niebezpiecznych substancji w sprzęcie elektrycznym i elektronicznym

<p>2006/42/CE, astfel a fost modificată Directiva privind echipamentele 2014/30/UE, astfel a fost modificată Directiva privind compatibilitatea electromagnetică 2011/65/UE, astfel a fost modificată Directiva privind limitarea utilizării anumitor substanțe periculoase în echipamentele electrice și electronice</p> <p>Directiva sobre maquinaria modificada 2006/42/CE 2014/30/UE modificada Directiva Compatibilidad electromagnética 2011/65/UE modificada Directiva Restricción del uso de determinadas sustancias peligrosas en equipos eléctricos y electrónicos</p> <p>2006/42/CE como diretiva de máquinas alteradas 2014/30/UE como alteração da compatibilidade eletromagnética 2011/65/UE como restrição diretiva alterada da utilização de certas substâncias perigosas em equipamentos elétricos e eletrônicos</p>
<p>References to the relevant harmonised standards used or references to the other technical specifications in relation to which conformity is declared: Références des normes harmonisées pertinentes appliquées, y compris la date de celles-ci, ou des autres spécifications techniques, y compris la date de celles-ci, par rapport auxquelles la conformité est déclarée: Odnwołania do odnośnych norm zharmonizowanych, które zastosowano, wraz z datą normy, lub do innych specyfikacji technicznych, wraz z datą specyfikacji, w odniesieniu do których deklarowana jest zgodność: Trimiteri la standardele armonizate relevante folosite, inclusiv data standardului, sau trimiteri la celelalte specificații tehnice, inclusiv data specificațiilor, în legătură cu care se declară conformitatea: Referencias a las normas armonizadas pertinentes utilizadas, incluidas las fechas de las normas, o referencias a las otras especificaciones técnicas, incluidas las fechas de las especificaciones, respecto a las cuales se declara la conformidad: Referências às normas harmonizadas aplicáveis utilizadas, incluindo a data da norma, ou às outras especificações técnicas, incluindo a data da especificação, em relação às quais é declarada a conformidade:</p>
<p>EN 62841-1:2015 EN ISO 12100:2010 EN 55014-1:2017+A11:2020 EN 55014-2:2015 EN IEC 61000-3-2:2019 EN 61000-3-3:2013+A1:2019</p>
<p>Authorised signatory and technical file holder/signataire et responsable de la documentation technique autorisé/ podmiot uprawniony do wystawienia i adres prezechowywania dokumentacji technicznej/semnatar autorizat și deținător al dosarului tehnic/firmante autorizado y titular del expediente tecnico/ signatário autorizado e detentor da ficha técnica:</p> <p>Kingfisher International Products B.V., Rapenburgerstraat 175E, 1011 VM Amsterdam, The Netherlands</p>  <p>David Awe Group Quality Director</p>
<p>On 21/01/2022</p>

In more detail...

EC declaration of conformity

**UK
CA**

(UK) DECLARATION OF CONFORMITY

Product:

- 500W Tile Cutter
- TTB903TCH
- Serial number: from 000001 to 999999

Name and address of the manufacturer or his authorised representative:

Kingfisher International Products Limited
3 Sheldon Square
London W2 6PX
United Kingdom

This declaration of conformity is issued under the sole responsibility of the manufacturer.

Object of the declaration

Product	Model	EAN
500W Tile Cutter	TTB903TCH	5059340252629

The object of the declaration described above is in conformity with the relevant legislation:

Supply of Machinery (Safety) Regulations 2008 as amended
Electromagnetic Compatibility Regulations 2016 as amended
The Restriction of the use of Certain Hazardous Substances in Electrical and Electronic Equipment Regulations 2012 as amended

References to the relevant designated standards used or references to the other technical specifications in relation to which conformity is declared:

EN 62841-1:2015
EN ISO 12100:2010
EN 55014-1:2017+A11:2020
EN 55014-2:2015
EN IEC 61000-3-2:2019
EN 61000-3-3:2013+A1:2019

Signed for and on behalf of:

Kingfisher International Products Limited
3 Sheldon Square
London W2 6PX
United Kingdom

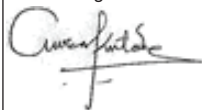

David Awe
Group Quality Director

On 21/01/2022



**Manufacturer • Fabricant • Producent
• Producător • Fabricante:**

UK manufacturer:

Kingfisher International Products Limited
3 Sheldon Square London W2 6PX
United Kingdom
www.kingfisher.com/products

EU manufacturer:

Kingfisher International Products B.V.
Rapenburgerstraat 175E
1011 VM Amsterdam
The Netherlands



www.diy.com | www.screwfix.com | www.screwfix.ie
To view instruction manuals online,
visit www.kingfisher.com/products
