

LUXPACK BATTEN



ASSEMBLY AND INSTALLATION **EN**

- This product must be disconnected before installation resistance testing of the lighting circuit
- Luminaire suitable for surface or suspension mounting
- Suitable for use with 220-240Vac

ZUSAMMENBAU UND INSTALLATION **DE**

- Dieses Produkt muss, vor der Messung des Isolationswiderstandes, von der Stromversorgung getrennt werden
- Die Leuchte ist geeignet für Aufputzmontage oder Seilabhängung
- Verwendbar mit 220-240 V/AC Last

NOTICE D'ASSEMBLAGE ET DE MONTAGE **FR**

- Ce produit doit être déconnecté avant l'essai de résistance du circuit d'éclairage
- Luminaire adapté au montage en saillie ou en suspension
- Convient pour une utilisation en 220-240V

MONTAJE E INSTALACIÓN **ES**

- Este producto debe desconectarse antes de la prueba de resistencia de instalación del circuito de iluminación
- Luminaria adecuada para montaje en superficie o suspensión
- Adecuado para usar con 220-240Vac

MONTAGGIO E INSTALLAZIONE **IT**

- Questo prodotto deve essere scollegato prima del test di resistenza all'installazione del circuito di illuminazione
- Lampada adatta per il montaggio di superfici o sospensioni
- Adatto per l'uso con 220-240

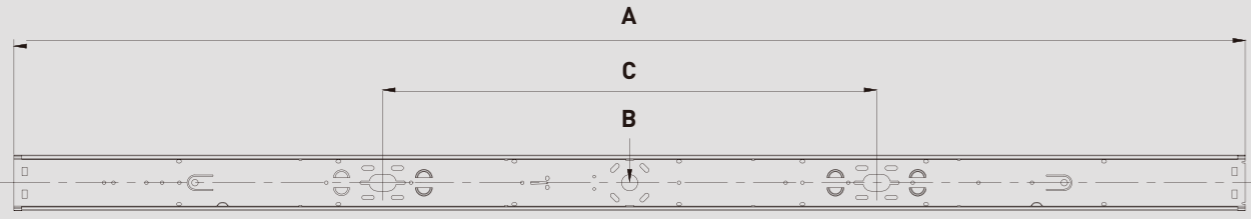

Part Code	A) Length	B) Centre Entry	C) Besa Fixings
LXB12Wxxx	4ft/1200mm	✓	600mm
LXB15Wxxx	5ft/1500mm	✓	600mm
LXB18Wxxx	6ft/1800mm	✓	600mm

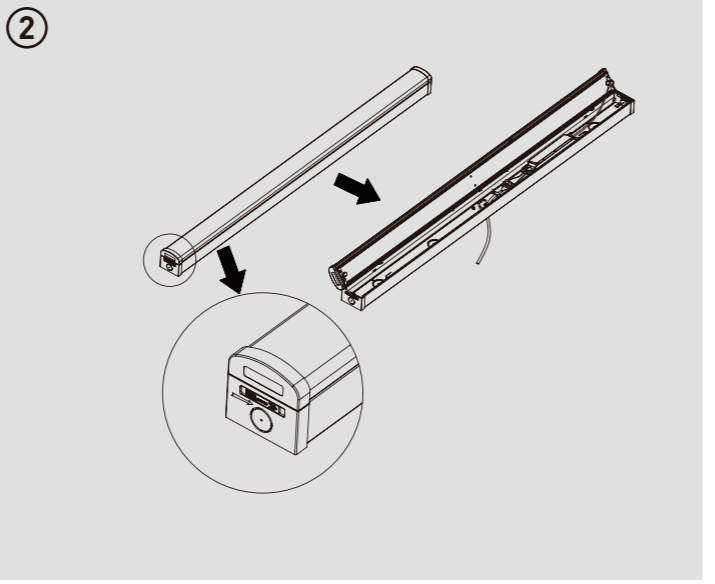
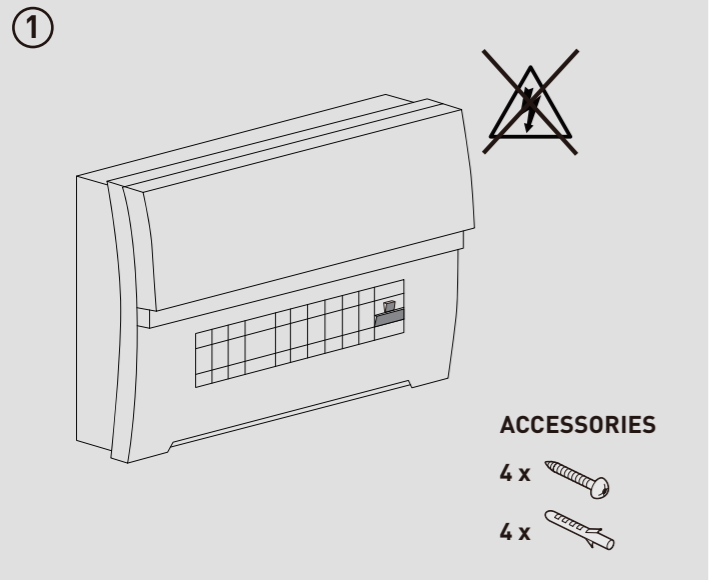

Tech Help Line UK - 0330 0249 279 Non UK - +44 (0)1952 238 100 Stafford Park 1, Telford, Shropshire, England, TF3 3BD	Kontakt UK - 0330 0249 279 Non UK - +49 40 89066 878 - 29 (Fax) Geliefert von Luceco GmbH Holstenplatz 20b, 22765 Hamburg DEUTSCHLAND	Support Technique UK - 0330 0249 279 Non UK - +33 (0)1 61 10 10 35 Notice fournie par Luceco SAS France & Belux 3 Rue de Courtalin, Magny Le Hongre 77700 FRANCE & BELUX	Servicio de asistencia telefónica UK - 0330 0249 279 Non UK - +34 93 829 55 74 (EU) Luceco SE C/ Bobinadora 1-5 08302 Mataró Barcelona Spain	Assistenza tecnica telefonica UK - 0330 0249 279 Non UK - +39 0434 1696795 Fornito da BG Electrical Ltd Nexus Italia, Via Amman 10 33170 Pordenone, Italy
--	--	--	---	--

Visit our website at www.luceco.com Besuchen Sie uns auf www.luceco.de Visitez note site Web www.luceco.fr Visite nuestra web en www.luceco.com Visitate il nostro sito www.luceco.com

3 Feed cable through entry point. Loosen clips with screwdriver, connect to terminal block, tighten the screws.

DE - Führen Sie das Kabel durch die Kabeldurchführung, lösen Sie die Befestigungsclips mit einem Schraubendreher, schließen Sie die Kabel an den Klemmblock an und ziehen Sie die Schrauben fest

FR - Faites passer le câble par le point d'entrée, desserrez les clips avec un tournevis, connectez-le au bornier et serrez les vis

IT - Inserire il cavo attraverso il punto di ingresso, allentare le clip con un cacciavite, collegare alla morsettiera e serrare le viti

ES - Pase el cable de alimentación a través de la entrada, abra clip con el destornillador, conecte al bloque de terminales y aprete los tornillos

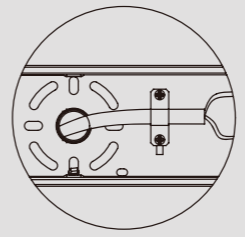

4

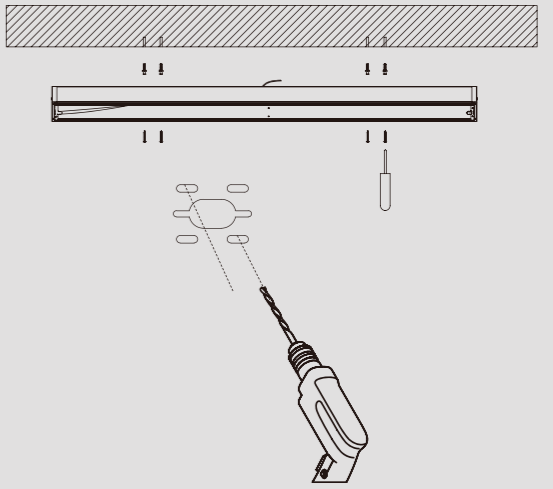

5 STANDARD
DE - Standard IT - Standard
FR - Standard ES - Estandar

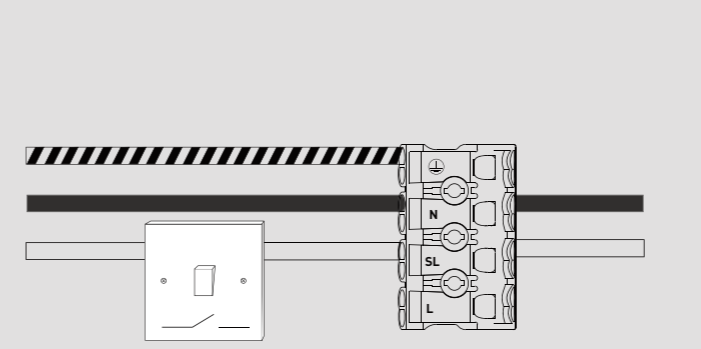

6 EMERGENCY
DE - Notbeleuchtung IT - EMERGENZA
FR - URGENCE ES - Emergencia

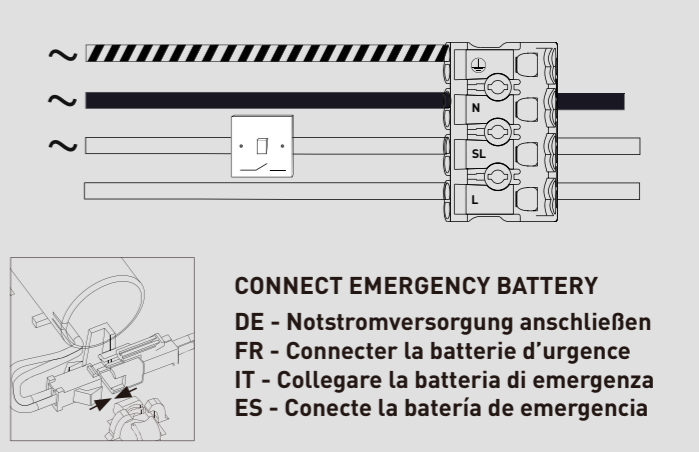

7 Connect safety hook and close cover.

DE - Sicherheitshaken anschließen und Abdeckung schließen.
FR - Connectez le crochet de sécurité et fermez le couvercle.
IT - Collegare il gancio di sicurezza e chiudere il coperchio.
ES - Fije el gancho de seguridad y cierre la cubierta.

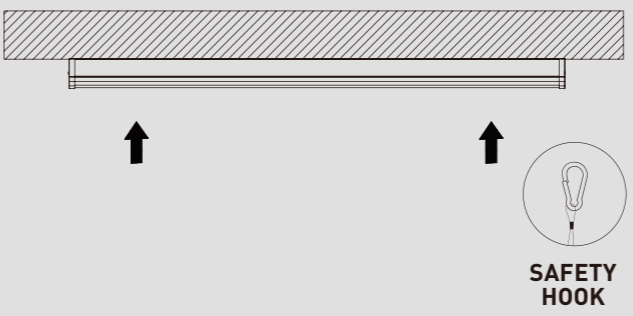

8

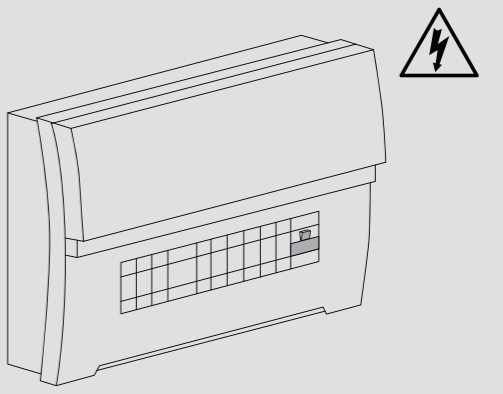

Tech Help Line UK - 0330 0249 279 Non UK - +44 (0)1952 238 100 Stafford Park 1, Telford, Shropshire, England, TF3 3BD	Kontakt UK - 0330 0249 279 Non UK - +49 40 89066 878 - 29 (Fax) Geliefert von Luceco GmbH Holstenplatz 20b, 22765 Hamburg DEUTSCHLAND	Support Technique UK - 0330 0249 279 Non UK - +33 (0)1 61 10 10 35 Notice fournie par Luceco SAS France & Belux 3 Rue de Courtalin, Magny Le Hongre 77700 FRANCE & BELUX	Servicio de asistencia telefónica UK - 0330 0249 279 Non UK - +34 93 829 55 74 (EU) Luceco SE C/ Bobinadora 1-5 08302 Mataró Barcelona Spain	Assistenza tecnica telefonica UK - 0330 0249 279 Non UK - +39 0434 1696795 Fornito da BG Electrical Ltd Nexus Italia, Via Amman 10 33170 Pordenone, Italy
--	--	--	---	--

Visit our website at www.luceco.com Besuchen Sie uns auf www.luceco.de Visitez note site Web www.luceco.fr Visite nuestra web en www.luceco.com Visitate il nostro sito www.luceco.com