

INCLUDED IN YOUR VAN VAULT

A 2 x KEYS
(located in key box)

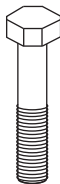

B 4 x M10 BOLTS



C 4 x M10 SHEAR NUTS



D 4 x M10 WASHERS



REMOVING AND INSTALLING THE DRAWER

1 Empty the draw and open drawer to full extension.

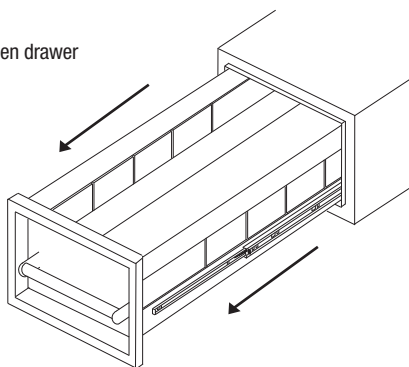

2 Push the locking pin up on the left hand side runner and slide the runner back

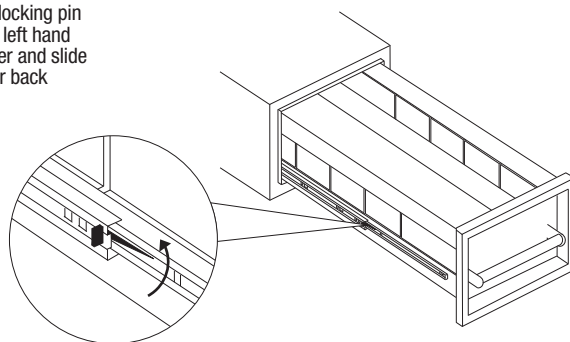

3 Push the locking pin down on the right hand side runner and slide the runner back

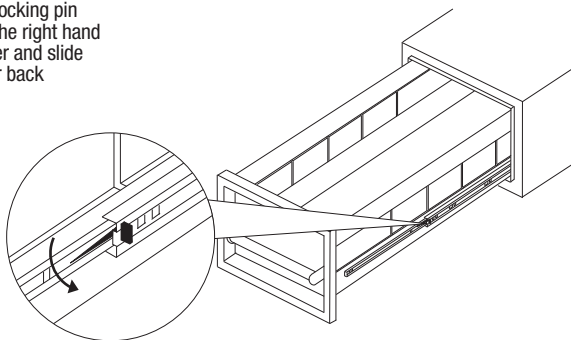

4 Using a large flat blade screwdriver push both runners back into the unit until they stop moving

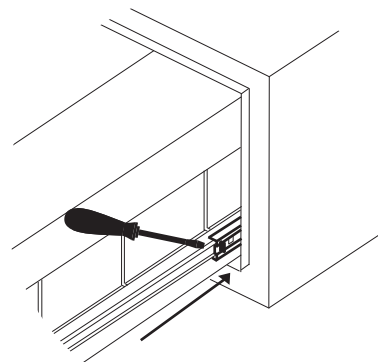

The drawer will now be free to lift out

INSTALLING THE VAN VAULT IN YOUR VEHICLE

IMPORTANT

If you choose to fit your Van Vault product in a vehicle, the 4 x M10 bolts (B), M10 shear nuts (C) and washers (D) provided with the Van Vault must be used to secure the unit through the base of the vehicle.

Ensure that you consult and follow your vehicle handbook, or the instructions of your vehicle manufacturer/local dealership, to locate the appropriate fitting point(s)/method of fitting for this product. Do this before installation to avoid damage to your vehicle. We do not accept liability or responsibility for any damage to, or effects on, a vehicle caused by incorrect fitting or installation or the selection of inappropriate fittings.

The integrity of the Van Vault is dependent on the drawer being installed securely. If in any doubt please contact a competent installer or Van Vault directly on **0115 780 2383**.

Nothing in these instructions shall exclude or limit our liability for (a) death or personal injury caused by our negligence, (b) fraud or fraudulent misrepresentation and (c) any other matter which it would be illegal for us to exclude.

TO REINSTALL THE DRAWER

Place the rear of the drawer in the unit
Align the runners and close the draw fully and lock.

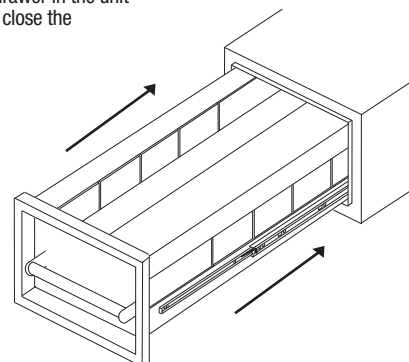

MAINTENANCE

Due to the harsh environments Van Vault's are used in, it is recommended that regular maintenance is performed on the Van Vault Disc Locks to keep them in full working order.

A full inspection and cleaning of the lock(s) should be undertaken every 3-6 months.

If the lock(s) are continually subjected to dust and dirt this inspection should be more regular, we recommend every three months.

It is best to remove the Van Vault Disc Lock when performing maintenance, please follow the steps opposite:-

- 1** Unscrew the 2 M6 nuts on the internal lock housing to remove the lock housing and Van Vault Disc Lock, noting the orientation of the lock.

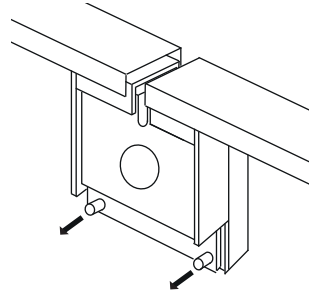

- 2** Locate the keyhole and the 4 holes on the back of the disc lock and blow all dust and dirt out the lock using a compressor or a pressurised canister.

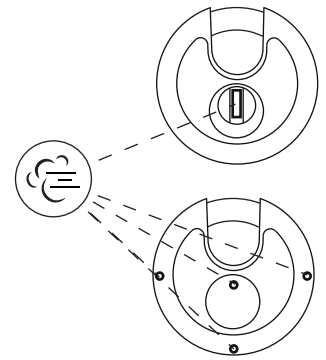

- 3** Lubricate lightly in the 4 small holes and the key hole. We recommend using a lubricant spray that contains PTFE additives for the best performance.

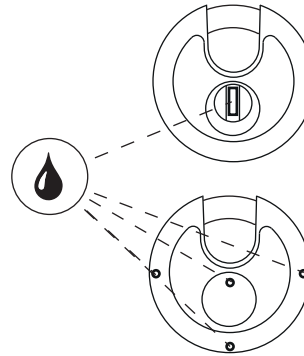

- 4** Insert the key and open and close the lock multiple times to ensure the lock is working freely. Re-attach the disc lock and the lock housing using the 2 M8 nuts.

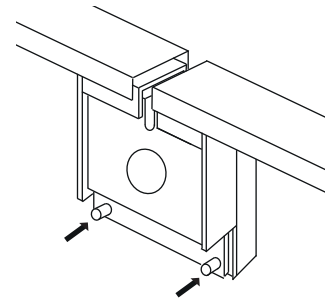

DRAWER SYSTEMS

USER INSTRUCTIONS



www.vanvault.co.uk

Van Vault - designed and distributed by Birchwood Price Tools.
Birchwood Price Tools is a trading name of Toolstream Limited.