

# INCLUDED IN YOUR VAN VAULT

**A 2 x KEYS**  
(located in key box)

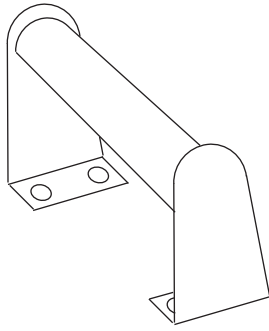

**B LID HANDLE**



**C 4 x BOLTS**  
(2x spare)

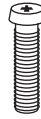

**D 4 x M10 BOLTS**

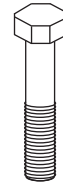

**E 4 x M10 SHEAR NUTS**



**F 4 x M10 WASHERS**



## OPENING/CLOSING THE VAN VAULT USING THE 'LID STAY'

### OPENING

Always ensure when opening the Van Vault lid, that the 'lid stay' has engaged before letting go.

### CLOSING

Holding the handle with one hand lightly lift the lid and disengage the 'lid stay'. Keeping hold of the handle and 'lid stay' close the box until the lid stay is clear of its locking point.

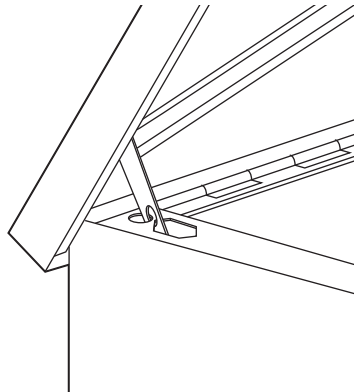

## ATTACHING THE HANDLE

Use the 4 x bolts (C) provided to attach the handle (B) to the front of the lid.

**Do not over tighten the bolts, they should only be pinch tight.**

**DO NOT OVER TIGHTEN THE BOLTS**

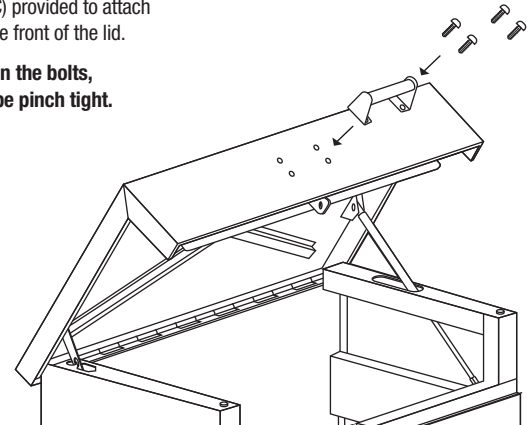

## MAINTENANCE

Due to the harsh environments Van Vault's are used in, it is recommended that regular maintenance is performed on the Van Vault Disc Locks to keep them in full working order.

A full inspection and cleaning of the lock(s) should be undertaken every 3-6 months.

If the lock(s) are continually subjected to dust and dirt this inspection should be more regular, we recommend every three months.

It is best to remove the Van Vault Disc Lock when performing maintenance, please follow the steps opposite:-

**1** Unscrew the 2 M8 nuts on the internal lock housing to remove the lock housing and Van Vault Disc Lock, noting the orientation of the lock.

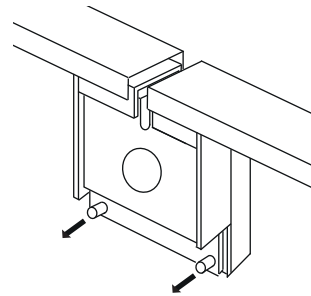

**2** Locate the keyhole and the 4 holes on the back of the disc lock and blow all dust and dirt out the lock using a compressor or a pressurised canister.

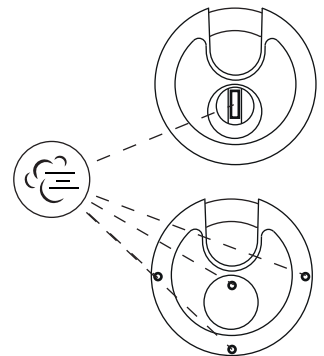

**3** Lubricate lightly in the 4 small holes and the key hole. We recommend using a lubricant spray that contains PTFE additives for the best performance.

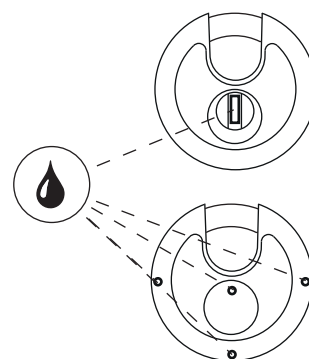

**4** Insert the key and open and close the lock multiple times to ensure the lock is working freely. Re-attach the disc lock and the lock housing using the 2 M8 nuts.

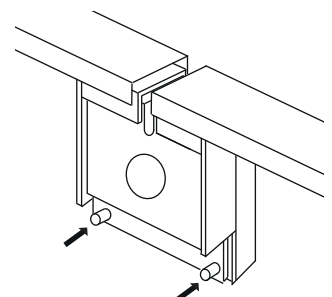

## INSTALLING THE VAN VAULT IN YOUR VEHICLE

### IMPORTANT

If you choose to fit your Van Vault product in a vehicle, the 4 x M10 bolts (D), M10 shear nuts (E) and washers (F) provided with the Van Vault must be used to secure the unit through the base of the vehicle.

Ensure that you consult and follow your vehicle handbook, or the instructions of your vehicle manufacturer/local dealership, to locate the appropriate fitting point(s)/method of fitting for this product. **Do this before installation** to avoid damage to your vehicle. We do not accept liability or responsibility for any damage to, or effects on, a vehicle caused by incorrect fitting or installation or the selection of inappropriate fittings.

The integrity of the Van Vault is dependent on the box being installed securely. If in any doubt please contact a competent installer or Van Vault directly on **0115 780 2383**.

Nothing in these instructions shall exclude or limit our liability for (a) death or personal injury caused by our negligence, (b) fraud or fraudulent misrepresentation and (c) any other matter which it would be illegal for us to exclude.



# USER INSTRUCTIONS



[www.vanvault.co.uk](http://www.vanvault.co.uk)

Van Vault - designed and distributed by Birchwood Price Tools.  
Birchwood Price Tools is a trading name of Toolstream Limited.