

Art.Nr.
4901402901
AusgabeNr.
4901402850
Rev.Nr.
09/06/2017



scheppach



DECO-FLEX

D	Dekupiersäge Original-Betriebsanweisung
GB	Scroll Saw Translation from the original instruction manual
FR	Scie alternative à découper Traduction du manuel d'origine
IT	Segatrice a svolgerre Traduzione dalle istruzioni d'uso originali
PL	Wyrzynarka Tłumaczenie oryginalu instrukcji obsługi
CZ	Lupínková pila Překlad originálního návodu k obsluze
SK	Lupienková píla Preklad originálneho návodu na obsluhu
SI	Dekupirna žaga Prevod originalnih navodil za uporabo

EE	Jõhvsaag Preklad originálneho návodu na obsluhu
LT	Siūlinis Pjūklas Vertimas iš originalaus eksploatavimo vadovo
LV	Figūrzāģis Tulkojums no lietošanas instrukcijas oriģināla
NL	Decoupeerzaag Vertaling van de originele handleiding
FI	Kuviosaha Käännös alkuperäisestä käyttöohjeesta
HU	Dekopírfűrészekre Eredeti használati utasítás fordítása

Nachdrucke, auch auszugsweise, bedürfen der Genehmigung. Technische Änderungen vorbehalten. Abbildungen beispielhaft!

Fig. 1



Fig. 2

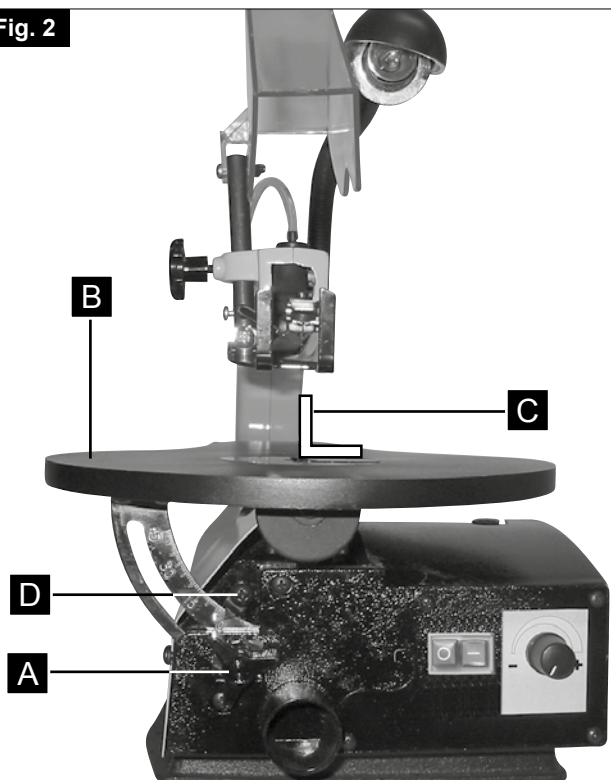

Fig. 3



Fig. 4

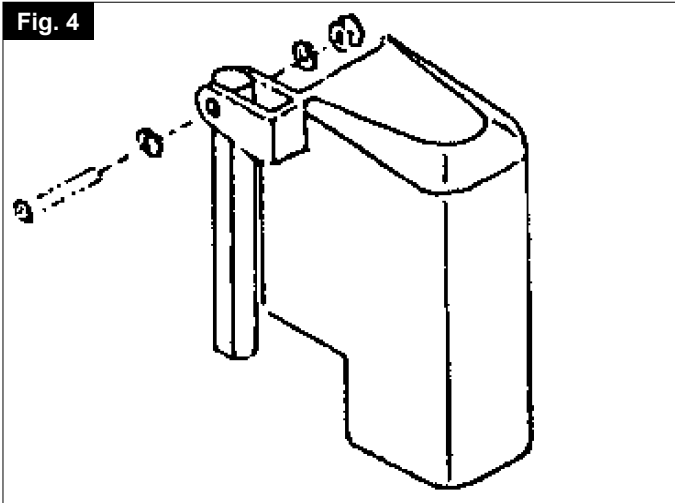

Fig. 5

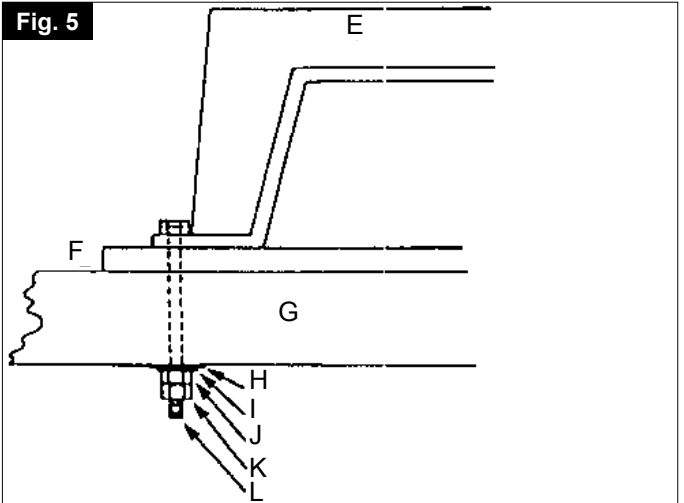

Fig. 6

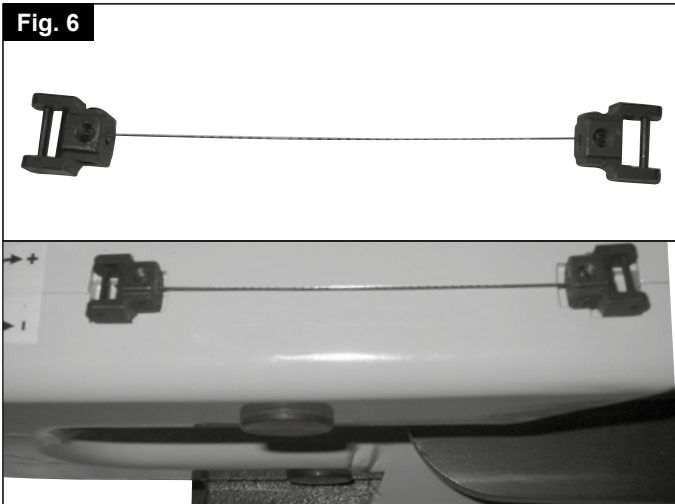

Fig. 7



Fig. 8

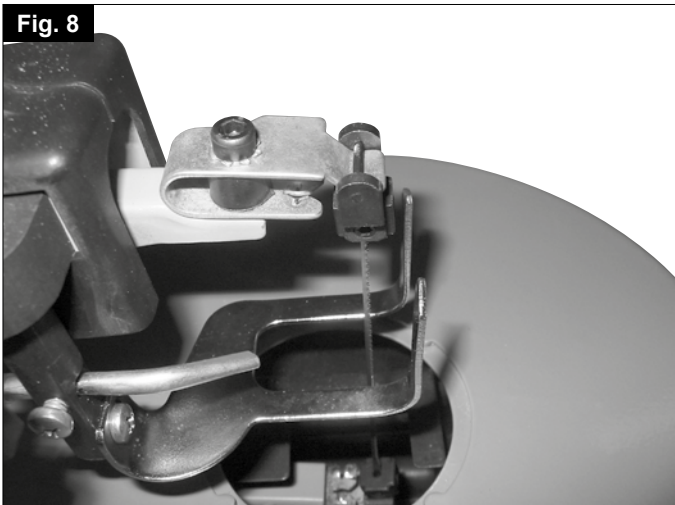

Fig. 9

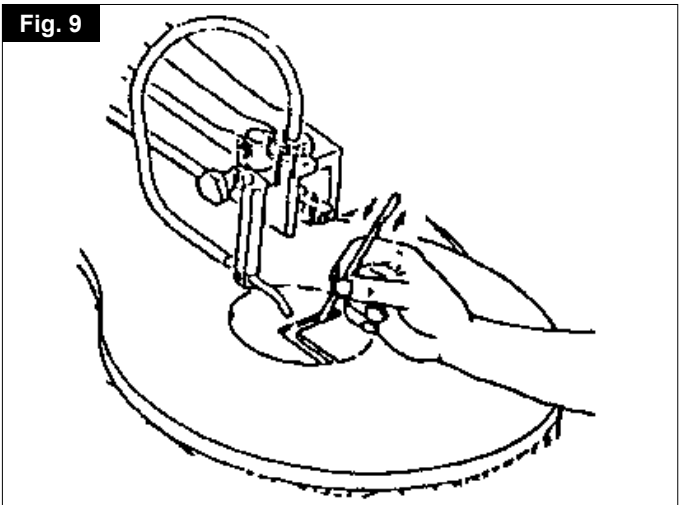

Fig. 10

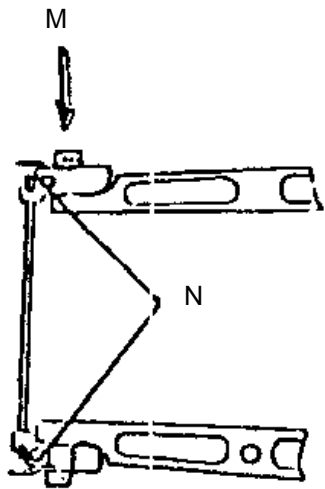

Fig. 11

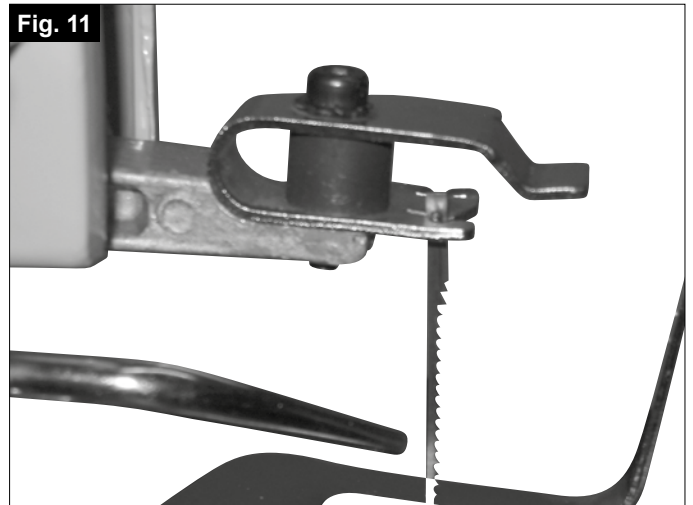

Fig. 12

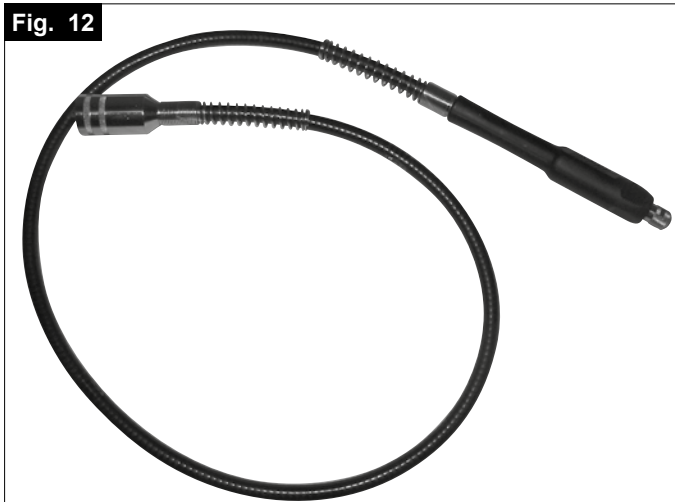

Fig. 13

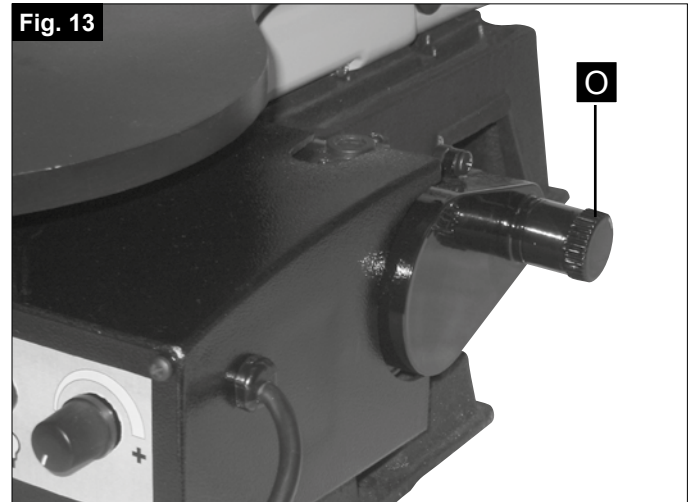

Fig. 14

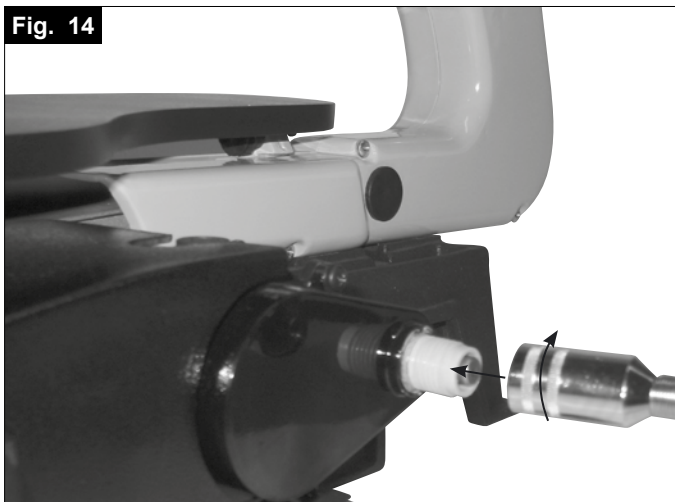
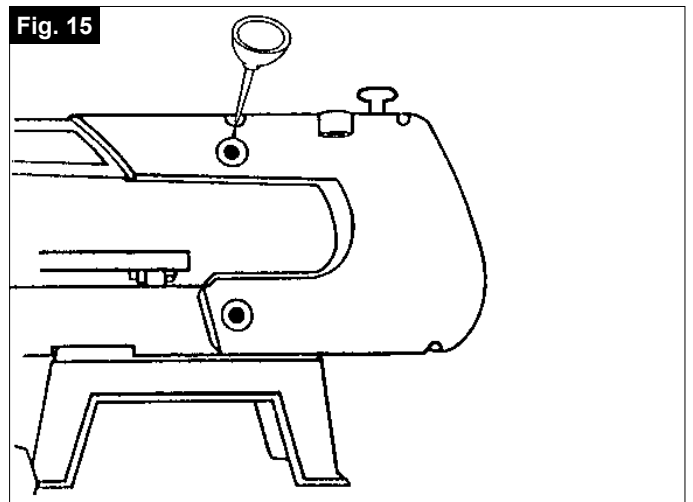
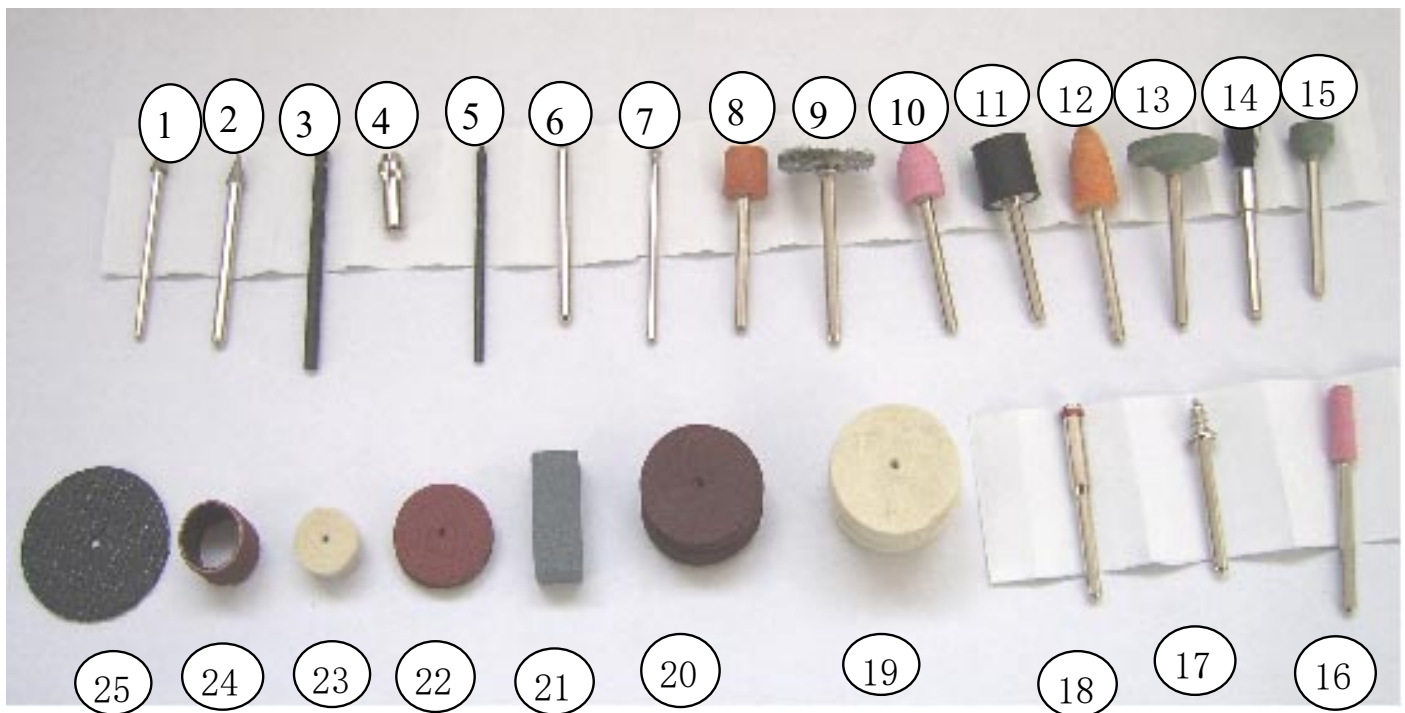

Fig. 15





Item	Description	Specification	Haft Diameter	Quantity
1	De-Burring Tool	Φ3.9x6.6	2.3	1
2	De-Burring Tool	Φ4.3x8.5	3.1	1
3	Drill Bit	Φ3.2x27	3.2	1
4	Tool Arbour / Collet	Φ2.3-2.4	Φ5	1
5	Drill Bit	Φ2.3x24	2.3	1
6	Engraving Tool	Φ3	3.1	1
7	Engraving Tool	Φ2.5	2.3	1
8	Sanding Drum	Φ9.8x10	3.1	1
9	Wire Brush	Φ22x2.5	3.1	1
10	Glass Engraver - Fine	Φ10x15	3.1	1
11	Arbour - Sanding Sleeve	Φ12.5x13.3	3.1	1
12	Glass Engraver - Medium	Φ10x19	3.1	1
13	Glass Engraver - Course	Φ20x3	3.1	1
14	De-Burring Tool	Φ3.5x10(PVC)	3.1	1
15	Glass Engraver Stone - Disc (Course)	Φ10X3.4	3.1	1
16	Fluted Glass Engraver (Fine)	Φ5.4X15	3.1	1
17	Screw Thread	Φ4X7.5	3.1	1
18	Arbour For Cutting Discs	Φ4.5X17	3.1	1
19	Polishing Pads	Φ25.5x6		3
20	Abrasive Sanding Discs	Φ24x0.6		20
21	Sharpening Slip Stone	9.8x9.8x25		1
22	Abrasive Sanding Discs	Φ20.2x0.4		10
23	Polishing Pads	Φ13x7		3
24	Sanding Sleeves	Φ12.5X13 δ1		6
25	Abrasive Cutting Discs	Φ32x1.2		3

Table of contents:	Page:
1. Introduction	17
2. Device description	17
3. Scope of delivery	17
4. Intended use	17
5. Safety information	18
6. Technical data	19
7. Installation	20
8. Operation	21
9. Maintenance	21
10. Storage	22
11: Electrical connection	22
12. Disposal and recycling	22
13. Troubleshooting	23
14. Declaration of conformity	133
15. Guarantee certificate	135

Explanation of the symbols on the equipment



Read the operating instructions to reduce the risk of injury



Wear safety goggles. Sparks generated during working or splinters, chips and dust emitted by the device can cause loss of sight.



Wear a breathing mask. Dust which is injurious to health can be generated when working on wood and other materials. Never use the device to work on any materials containing asbestos!

1. Introduction

Manufacturer:

scheppach

Fabrikation von Holzbearbeitungsmaschinen GmbH
Günzburger Straße 69
D-89335 Ichenhausen

Dear customer,
we wish you a pleasant and successful working experience with your new scheppach Scroll Saw.

Note:

According to the applicable product liability law the manufacturer of this device is not liable for damages which arise on or in connection with this device in case of:

- improper handling
- non-compliance with the instructions for use
- repairs by third party, non authorized skilled workers
- installation and replacement of non-original spare parts
- improper use
- failures of the electrical system due to the non-compliance with the electrical specifications and the VDE 0100, DIN 57113 / VDE 0113 regulations

Warning

To avoid electrical hazards, fire hazards, or damage to the tool, use proper circuit protection.

Your drill press is wired at the factory for 230 V operation. Connect to a 230 V/15 amp branch circuit and use a 15 amp time delay fuse or circuit breaker. To avoid shock or fire, replace power cord immediately if it is worn, cut or damaged in any way.

Recommendations:

Read the entire text of the operating instructions prior to the assembly and operation of the device.

These operating instructions are intended to make it easier for you to get familiar with your device and utilize its intended possibilities of use.

The operating instructions contain important notes on how to work safely, properly and economically with your machine and how to avoid dangers, save repair costs, reduce downtime, and increase the reliability and working life of the machine. In addition to the safety regulations contained herein, you must in any case comply with the applicable regulations of your country with respect to the operation of the machine. Put the operating instructions in a clear plastic folder to protect them from dirt and humidity, and store them near the machine. The instructions must be read and carefully observed by each operator prior to starting the work. Only persons who have been trained in the use of the machine and have been informed on the related dangers and risks are allowed to use the machine. The required minimum age must be met. In addition to the safety notes contained in the present operating instructions and the special regulations of your country, the generally recognized technical rules for the operation of wood working machines must be observed.

2. Device description (Fig. 1)

1. Clamping screw: for removing the saw blade.
2. Blade guard: protects your hands from injury.
3. Work piece holder
4. Shavings blower: keeps the workpiece area free from dust.
5. electronical speed switch deco 402: Speed switch
6. On/Off switch
7. Angle scale: you can read the angle position of the table with this scale.
8. Lighting
9. Flexible shaft with drill chuck
10. Setting gauge for saw blades without pin

3. Scope of delivery

- When you unpack the device, check all parts for possible transport damages. In case of complaints the supplier is to be informed immediately.
- Complaints received at a later date will not be acknowledged.
- Check the delivery for completeness.
- Read the operating instructions to make yourself familiar with the device prior to using it.
- Only use original scheppach parts for accessories as well as for wearing and spare parts. Spare parts are available from your specialized dealer.
- Specify our part numbers as well as the type and year of construction of the device in your orders.

⚠ ATTENTION

The device and packaging materials are not toys! Children must not be allowed to play with plastic bags, film and small parts! There is a risk of swallowing and suffocation!

4. Intended use

CE tested machines meet all valid EC machine guidelines as well as all relevant guidelines for each machine.

- The machine must only be used in technically perfect condition in accordance with its designated use and the instructions set out in the operating manual, and only by safety-conscious persons who are fully aware of the risks involved in operating the machine. Any functional disorders, especially those affecting the safety of the machine, should therefore be rectified immediately.
- The safety, work and maintenance instructions of the manufacturer as well as the technical data given in the calibrations and dimensions must be adhered to.
- Relevant accident prevention regulations and other, generally recognized safety-technical rules must also be adhered to.

- The machine may only be used, maintained, and operated by persons familiar with it and instructed in its operation and procedures. Arbitrary alterations to the machine release the manufacturer from all responsibility for any resulting damages.
- The machine may only be used with original accessories and tools made by the manufacturer.
- Any other use exceeds authorization. The manufacturer is not responsible for any damages resulting from unauthorized use; risk is the sole responsibility of the operator.

Please note that our equipment has not been designed for use in commercial, trade or industrial applications. Our warranty will be voided if the equipment is used in commercial, trade or industrial businesses or for equivalent purposes.

5. Safety information

Attention! The following basic safety measures must be observed when using electric tools for protection against electric shock, and the risk of injury and fire. Read all these notices before using the electric tool and keep the safety instructions for later reference.

Safe work

- 1 Keep the work area orderly
 - Disorder in the work area can lead to accidents.
- 2 Take environmental influences into account
 - Do not expose electric tools to rain.
 - Do not use electric tools in a damp or wet environment.
 - Make sure that the work area is well-illuminated.
 - Do not use electric tools where there is a risk of fire or explosion.
- 3 Protect yourself from electric shock
 - Avoid physical contact with earthed parts (e.g. pipes, radiators, electric ranges, cooling units).
- 4 Keep children away
 - Do not allow other persons to touch the equipment or cable, keep them away from your work area.
- 5 Securely store unused electric tools
 - Unused electric tools should be stored in a dry, elevated or closed location out of the reach of children.
- 6 Do not overload your electric tool
 - They work better and more safely in the specified output range.
- 7 Use the correct electric tool
 - Do not use low-output electric tools for heavy work.
 - Do not use the electric tool for purposes for which it is not intended. For example, do not use hand-held circular saws for the cutting of branches or logs.
 - Do not use the electric tool to cut firewood.

- 8 Wear suitable clothing
 - Do not wear wide clothing or jewellery, which can become entangled in moving parts.
 - When working outdoors, anti-slip footwear is recommended.
 - Tie long hair back in a hair net.
- 9 Use protective equipment
 - Wear protective goggles.
 - Wear a mask when carrying out dust-creating work.
- 10 Connect the dust extraction device
 - If connections for dust extraction and a collecting device are present, make sure that they are connected and used properly.
 - Operation in enclosed areas is only permitted with a suitable extraction system.
- 11 Do not use the cable for purposes for which it is not intended
 - Do not use the cable to pull the plug out of the outlet. Protect the cable from heat, oil and sharp edges.
- 12 Secure the workpiece
 - Use the clamping devices or a vice to hold the workpiece in place. In this manner, it is held more securely than with your hand.
 - An additional support is necessary for long workpieces (table, trestle, etc.) in order to prevent the machine from tipping over.
 - Always press the workpiece firmly against the working plate and stop in order to prevent bouncing and twisting of the workpiece.
- 13 Avoid abnormal posture
 - Make sure that you have secure footing and always maintain your balance.
 - Avoid awkward hand positions in which a sudden slip could cause one or both hands to come into contact with the saw blade.
- 14 Take care of your tools
 - Keep cutting tools sharp and clean in order to be able to work better and more safely.
 - Follow the instructions for lubrication and for tool replacement.
 - Check the connection cable of the electric tool regularly and have it replaced by a recognised specialist when damaged.
 - Check extension cables regularly and replace them when damaged.
 - Keep the handle dry, clean and free of oil and grease.
- 15 Pull the plug out of the outlet
 - Never remove loose splinters, chips or jammed wood pieces from the running saw blade.
 - During non-use of the electric tool or prior to maintenance and when replacing tools such as saw blades, bits, milling heads.
- 16 Do not leave a tool key inserted
 - Before switching on, make sure that keys and adjusting tools are removed.

- 17** Avoid inadvertent starting
- Make sure that the switch is switched off when plugging the plug into an outlet.
- 18** Use extension cables for outdoors
- Only use approved and appropriately identified extension cables for use outdoors.
 - Only use cable reels in the unrolled state.
- 19** Remain attentive
- Pay attention to what you are doing. Remain sensible when working. Do not use the electric tool when you are distracted.
- 20** Check the electric tool for potential damage
- Protective devices and other parts must be carefully inspected to ensure that they are fault-free and function as intended prior to continued use of the electric tool.
 - Check whether the moving parts function faultlessly and do not jam or whether parts are damaged. All parts must be correctly mounted and all conditions must be fulfilled to ensure fault-free operation of the electric tool.
 - The moving protective hood may not be fixed in the open position.
 - Damaged protective devices and parts must be properly repaired or replaced by a recognised workshop, insofar as nothing different is specified in the operating manual.
 - Damaged switches must be replaced at a customer service workshop.
 - Do not use any faulty or damaged connection cables.
 - Do not use any electric tool on which the switch cannot be switched on and off.
- 21 ATTENTION!**
- Exercise elevated caution for double mitre cuts.
- 22 ATTENTION!**
- The use of other insertion tools and other accessories can entail a risk of injury.
- 23** Have your electric tool repaired by a qualified electrician
- This electric tool conforms to the applicable safety regulations. Repairs may only be performed by an electrician using original spare parts. Otherwise accidents can occur.

Warning! This electric tool generates an electromagnetic field during operation. This field can impair active or passive medical implants under certain conditions. In order to prevent the risk of serious or deadly injuries, we recommend that persons with medical implants consult with their physician and the manufacturer of the medical implant prior to operating the electric tool.

ADDITIONAL SAFETY RULES FOR SCROLL SAWS

- This scroll saw is intended for use in dry conditions, and for indoor use only.
 - Do not cut pieces of material too small to hold by hand outside the blade guard.
 - Avoid awkward hand positions where a sudden slip could cause a hand to move into the blade.
- Always use the blade guard to avoid possible injury due to blade breakage.
 - Never leave the scroll saw work area with the power (01), or before the machine has come to a complete stop.
 - Do not perform layout, assembly or set up work on the table while the cutting tool is in operation.
 - Never turn your scroll saw on before clearing the table of all objects: (tools, scraps of wood, etc) except for the workpiece and related feed or support devices for the operation planned.

Remaining hazards

The machine has been built using modern technology in accordance with recognized safety rules. Some remaining hazards, however, may still exist.

- Long hair and loose clothing can be hazardous when the work piece is rotating. Wear personal protective gear such as a hair net and tight fitting work clothes.
- Saw dust and wood chips can be hazardous. Wear personal protective gear such as safety goggles and a dust mask.
- The use of incorrect or damaged mains cables can lead to injuries caused by electricity.
- Even when all safety measures are taken, some remaining hazards which are not yet evident may still be present.
- Remaining hazards can be minimized by following the instructions in „Safety Precautions“, „Proper Use“ and in the entire operating manual.
- Do not force the machine unnecessarily: excessive cutting pressure may lead to rapid deterioration of the blade and a decrease in performance in terms of finish and cutting precision.
- Avoid accidental starts: do not press the start button while inserting the plug into the socket.

Keep this safety information in a safe place.

6. Technical data

deco-flex	
Extent of delivery	
	Scroll saw
	Flexible Wave
	Accessories kit
	Operating instructions
Technical data	
Dimensions L x W x H mm	630 x 320 x 380
Bench size mm	ø 255 x 415
Saw blade length mm	133
Cutting height max. mm	50
Working depth mm	405
Lifting movement mm	15
Lifting speed 1/min (electrical)	550 – 1650
Bench diagonal adjustment left degrees	0 – 45
Weight kg	15,0
Suction connection piece ø mm	35
Motor	
Electrical motor	230-240 V~/50 Hz
Power consumption P1 W	90
Sound pressure level on operator's ear measured in accordance with DIN 45635 with max. speed during idle running	77,3 dB (A)

7. Installation

Setting the saw bench, Fig. 2

Setting the angle scale

- Release the star button (A) and bring the saw bench (B) to a right angle (C) in relation to the saw blade.
- Use a 90° angle to measure the right angle between the blade and the bench. The saw blade be 90° to the angle.
- Close the star button again when the distance between the blade and the 90° angle is at a minimum. The bench should then be at 90° to the saw blade.
- Release the lock screw (D) and bring the indicator to the zero position. Fasten the screw. Please note: the angle scale is a useful piece of supplementary equipment, but should not be used for precision work. Use scrap wood for saw tests, adjust the bench if necessary.

Note: The bench should not be on the motor block, this can cause undesirable noise.

Horizontal saw bench and diagonal cuts, Fig. 2+3

- The saw bench can be positioned into a 45° diagonal position or be left in the horizontal position.
- You can read off the approximate slope angle by using the angle scale located under the work bench. For more exact adjustment, use scrap wood for some saw tests; adjust the bench if necessary.

Blade guard assembly, Fig. 4

Install the blade guard to the holder as shown in the diagram. Secure the screws with a nut and washer.

- Lift the saw onto the frame and base and push it onto the workbench.
- Familiarize yourself with the saw operating elements and features.

Mounting the saw on a work bench, Fig. 5

- A workbench made from solid wood is better than one made of plywood, as interfering vibrations and noise are more noticeable with plywood.
- The necessary tools and small parts for assembling the saw on a workbench are not supplied with the saw. However, use equipment of at least the following size:

- E Saw body
- F Foam rubber base
- G Work bench
- H Flat seal
- I Washer
- J Hexagonal nut
- K Lock nut
- L Hexagonal bolt

Quantity Description

- 4 Hexagonal bolts (6mm) 1/4-20 x length
 - 4 Flat seal (7mm) 9/321.0
 - 4 Washers (7mm) 9/321.0.
 - 8 Hexagonal nuts (6 mm) 1/4-20
- First of all, drill holes into the seating surface and then insert the screws.
- A foam rubber base for reduction of noise is not supplied with the saw either. However, we expressly recommend that you use such a base to keep vibration and noise to a minimum. Ideal size 400 x 240 mm.

CHANGING THE SAW BLADES

Warning: Switch off the saw and remove the mains supply plug before installing saw blades in order to avoid injuries caused by unintentional activation of the saw.

A. Flat saw-blades Fig. 6

Use the adapter with flat saw-blades. The saw-blade is fixed with Allen screws.

A 1 Saw-blade removal, fig. 7+8, 10

- Extract the saw-blade by sliding the table's inlay up, then unscrew the tightening screw (1).
- Slightly press the upper arm (M) down (fig. 10).
- Then remove the sawblade by pulling it forward out of the supports and through the access perforation in the table.

A 2 Inserting the saw-blade:

- Put the saw-blade with the two adapters into the lower support, the other end into the upper support.
- Slightly press the upper arm (M) down (fig 10) before hooking it in.

- Tighten the blade with the tightening screw (1) (fig.7) by rotating it clockwise. Check the tightness of the blade. Keep on rotating clockwise in order to tighten the blade even more.

B. Saw-blade with pins

B 1 Saw blade removal, fig. 7 + 8

- Extract the saw-blade by first unscrewing the tightening screw (1).
- Remove the saw-blade from the upper and lower support by slightly pressing the saw's upper arm down (fig. 10, M).

B 2 Inserting the saw-blade fig 7, 9-11

- Lead one end of the saw-blade through the perforation in the table and insert the saw-blade pins into the notch. Repeat this procedure at the upper blade support.
- Before hooking it in, slightly press the saw's upper arm down. (Fig 9; Nr. 10)
- Check the position of the blade pins at the supports (fig 11).
- Tighten the blade by means of the tightening screw. Check the blade's tightness. Keep on rotating clockwise in order to tighten the blade even more. (Fig. 7).

8. Operation

A scroll saw is fundamentally a „curve cutting tool“ but which can also carry out straight and angled edge cuts. Familiarise yourself with the following important points prior to commissioning the saw.

- The saw does not automatically cut wood. You must feed the wood against the saw blade manually.
- The cutting process occurs on l y while the blade is moving downwards.
- Feed the wood slowly against the saw blade as the saw blade teeth are small and cut only while moving downwards.
- All persons carrying out work with the saw require training. The saw blade may break easily during this training time lwhile the operator is sti1l unfamiliar with the saw.
- The saw is best suited for sheets of wood less than 2.5 cm thick.
- Feed the wood especially slowly against the blade and avoid abrupt curves to prevent the saw blade from breaking, if you wish to cut wood sheets thicker than 2.5 cm.
- Saw blade teeth blunten over time, saw blades must be replaced. The saw blades are sufficient for 1/2 to 2 operating time depending upon the type of wood.
- Try and make sure that the saw blade follows the grain of the wood in order to obtain a clean cut.
- The saw speed must be reduced to minimum when cutting precious and non-ferrous metals.

INSIDE CUTS

Warning: Switch off the saw and remove the mains supply plug before installing saw blades in order to avoid injuries caused by unintentional activation of the saw.

This saw is suited also to inside cuts cuts not starting at the edge of the work piece. Proceed as follows:

- Drill a 6 mm hole in the work piece.
- Loosen the blade tension er and release the tension in the blade.
- Place the bore hole over the saw blade slot in the work bench.
- Install the saw blade through the hole in the work piece and through the work blade slot, and fasten the blade to the holders.
- When you have completed the inside cut, remove the saw blade and then remove the workpiece from the bench.

Flexible shaft, Fig. 12-14

- Remove protective cap (O) from the threaded bushing (Fig. 13).
- Place flexible shaft onto the threaded bushing (Fig. 14).
- Clamp tool in the drill chuck (D 3.2).
- Firmly hold threaded shaft at the handle and switch on the speed control.
- Having finished the work, remove the flexible shaft and place the protective cap in place. Attention: When working with the flexible shaft, cover the saw blade with the blade guard.

9. Maintenance

Warning: In the interests of operational safety, always switch off the saw and remove the mains plug before carrying out maintenance work.

General

Wipe chips and dust off the machine from time to time using a cloth.

Re-application of the wax coating on the workbench makes feeding the workpiece to the blade easier.

Motor

The mains cable should be replaced immediately if pulled out, cut or damaged in any other way.

Do not lubricate the motor bearings or internal parts!

Saw arm bearings

Lubricate the saw arm bearings every 50 hours. Proceed as follows (Fig. 15).

- Turn the saw to the side
- Apply a generous amount of SAE 20 oil to the shaft end and bronze bearings.
- Let the lubricant oil work in overnight.
- Repeat the procedure the next day on the other side of the saw.

There are no parts inside the equipment which require additional maintenance.

Special accessories

Pin saw blade-universal
135 x 2,0 x 0,25 Z 10
blade mm 1 set = 6 pieces, Article No. **8800 0011**

Pin saw blade- wood/plastic mm
135 x 2,0 x 0,25 Z 7
1 set = 6 pieces, Article No. **8800 0012**

Pin saw blade-wood mm
135 x 3,0 x 0,5 Z 4
1 set = 6 pieces, Article No. **8800 0013**

Service information

Please note that the following parts of this product are subject to normal or natural wear and that the following parts are therefore also required for use as consumables.

Wear parts*: Carbon brushes, saw blade, table inlays; v-belt

* Not necessarily included in the scope of delivery!

10. Storage

Store the device and its accessories in a dark, dry and frost-proof place that is inaccessible to children. The optimum storage temperature is between 5 and 30°C. Store the electrical tool in its original packaging.

11. Electrical connection

The installed electric motor is completely wired ready for operation. The customer's connection to the power supply system, and any extension cables that may be used, must conform with local regulations.

IMPORTANT REMARK:

The motor is automatically switched off in the event of an overload. The motor can be switched on again after a cooling down period that can vary.

DEFECTIVE ELECTRICAL CONNECTION CABLES

Electrical connection cables often suffer insulation damage.

Possible causes are:

- Pinch points when connection cables are run through window or door gaps.
- Kinks resulting from incorrect attachment or laying of the connection cable.
- Cuts resulting from running over the connecting cable.
- Insulation damage resulting from forcefully pulling out of the wall socket.
- Cracks through aging of insulation.

Such defective electrical connection cables must not be used as the insulation damage makes them extremely hazardous.

Check electrical connection cables regularly for damage. Make sure the cable is disconnected from the mains when checking.

Electrical connection cables must comply with the regulations applicable in your country.

SINGLE-PHASE MOTOR

- The mains voltage must coincide with the voltage specified on the motor's rating plate.
- Extension cables up to a length of 25 m must have a cross-section of 1.5 mm², and beyond 25 m at least 2.5 mm².
- The connection to the mains must be protected with a 16 A slow-acting fuse.

Only a qualified electrician is permitted to connect the machine and complete repairs on its electrical equipment.

In the event of enquiries please specify the following data:

- Motor manufacturer
- Type of current of the motor
- Data recorded on the machine's rating plate
- Data recorded on the switch's rating plate

If a motor has to be returned, it must always be dispatched with the complete driving unit and switch.

12. Disposal and recycling

The equipment is supplied in packaging to prevent it from being damaged in transit. The raw materials in this packaging can be reused or recycled. Never place batteries in your household refuse, in fire or in water. Batteries should be collected, recycled or disposed of by environment-friendly means. The equipment and its accessories are made of various types of material, such as metal and plastic. Defective components must be disposed of as special waste. Ask your dealer or your local council.

13. Troubleshooting

Warning: In the interests of operational safety, always switch off the saw and remove the mains plug before carrying out maintenance work.

Fault	Possible causes	Action
Saw blades break	Tension incorrectly set	Set the correct tension
	Load too great	Feed the workpiece more slowly
	Incorrect saw blade variety	Use the correct saw blades
	Workpiece not fed straight	Avoid exerting pressure from the side
Motor does not function	Mains cable faulty	Change faulty parts
	Motor faulty	Call customer service. Do not attempt to repair the motor yourself as this should be carried out by trained personnel.
Vibration NOTE: The saw vibrates slightly when the motor is running in normal operation.	Saw incorrectly installed	Refer to the instructions given earlier in this manual for information on installing the saw
	Unsuitable underlay	The heavier the work bench is, the less the vibration. A bench made from ply wood always vibrates more than one made from solid wood. Select the work bench best suited to your working conditions
	The work bench is not screwed down or is on the motor	Tighten the locking lever
	The motor is not secured	Securely screw the motor in place
Saw blade swings out Holders not aligned straight	Holders not aligned	Loosen the screws with which the holders are fastened to the arm. Align the holders so that they are perpendicular to each other and retighten the screws.

Garantie DE

Offensichtliche Mängel sind innerhalb von 8 Tagen nach Erhalt der Ware anzuzeigen, andernfalls verliert der Käufer sämtliche Ansprüche wegen solcher Mängel. Wir leisten Garantie für unsere Maschinen bei richtiger Behandlung auf die Dauer der gesetzlichen Gewährleistungsfrist ab Übergabe in der Weise, dass wir jedes Maschinenteil, dass innerhalb dieser Zeit nachweisbar in Folge Material- oder Fertigungsfehler unbrauchbar werden sollte, kostenlos ersetzen. Für

Teile, die wir nicht selbst herstellen, leisten wir nur insoweit Gewähr, als uns Gewährleistungsansprüche gegen die Vorlieferanten zustehen. Die Kosten für das Einsetzen der neuen Teile trägt der Käufer. Wandlungs- und Minderungsansprüche und sonstige Schadensersatzansprüche sind ausgeschlossen.

Warranty GB

Apparent defects must be notified within 8 days from the receipt of the goods. Otherwise, the buyer's rights of claim due to such defects are invalidated. We guarantee for our machines in case of proper treatment for the time of the statutory warranty period from delivery in such a way that we replace any machine part free of charge which provably becomes unusable due to faulty material or defects of fabrication within such period of time. With respect to parts not

manufactured by us we only warrant insofar as we are entitled to warranty claims against the upstream suppliers. The costs for the installation of the new parts shall be borne by the buyer. The cancellation of sale or the reduction of purchase price as well as any other claims for damages shall be excluded.

Garantie FR

Les défauts visibles doivent être signalés au plus tard 8 jours après la réception de la marchandise, sans quoi l'acheteur perd tout droit au dédommagement.

Nous garantissons nos machines, dans la mesure où elles sont utilisées de façon conforme, pendant la durée légale de garantie à compter de la réception, sachant que nous remplaçons gratuitement toute pièce de la machine devenue inutilisable du fait d'un défaut de matière ou

d'usinage durant cette période. Toutes les pièces que nous ne fabriquons pas nous-mêmes ne sont garanties que si nous avons la possibilité d'un recours en garantie auprès des fournisseurs respectifs. Les frais de main d'œuvre occasionnés par le remplacement des pièces sont à la charge de l'acquéreur. Tous droits à réhabilitation et toutes prétentions à une remise ainsi que tous autres droits à dommages et intérêts sont exclus

Garanzia IT

Vizi evidenti vanno segnalati entro 8 giorni dalla ricezione della merce, altrimenti decadono tutti i diritti dell'acquirente inerenti a vizi del genere. Appurato un impiego corretto da parte dell'acquirente, garantiamo per le nostre macchine per tutto il periodo legale di garanzia a decorrere dalla consegna in maniera tale che sostituiamo gratuitamente qualsiasi componente che entro tale periodo presenti dei vizi di materiale o di fabbricazione tali da renderlo inutilizzabile. Per

componenti non fabbricati da noi garantiamo solo nella misura nella quale noi stessi possiamo rivendicare diritti a garanzia nei confronti dei nostri fornitori. Le spese per il montaggio dei componenti nuovi sono a carico dell'acquirente. Sono escluse pretese di risoluzione per vizi, di riduzione o ulteriori pretese di risarcimento danni.

Garantie NL

Zichtbare gebreken moeten binnen de 8 dagen na ontvangst van de goederen worden gemeld, zo niet verliest de verkoper elke aanspraak op grond van deze gebreken. Onze machines worden geleverd met een garantie voor de duur van de wettelijke garantietermijn. Deze termijn gaat in vanaf het moment dat de koper de machine ontvangt. De garantie houdt in dat wij elk onderdeel van de machine dat binnen de garantietermijn aantoonbaar onbruikbaar wordt als gevolg van materiaal- of productiefouten, kosteloos vervangen. De garantie vervalt echter bij

verkeerd gebruik of verkeerde behandeling van de machine. Voor onderdelen die wij niet zelf produceren, geven wij enkel de garantie die wij zelf krijgen van de oorspronkelijke leverancier. De kosten voor de montage van nieuwe onderdelen vallen ten laste van de koper. Eisen tot het aanbrengen van veranderingen of het toestaan van een korting en overige schadeloosstellingsclaims zijn uitgesloten.

Garantía ES

Los defectos evidentes deberán ser notificados dentro de 8 días después de haber recibido la mercancía, de lo contrario el comprador pierde todos los derechos sobre tales defectos. Garantizamos nuestras máquinas en caso de manipulación correcta durante el plazo de garantía legal a partir de la entrega. Sustituiremos gratuitamente toda pieza de la máquina que dentro de este plazo se torne inútil a causa de fallas de material o de fabricación. Las piezas que no

son fabricadas por nosotros mismos serán garantizadas hasta el punto que nos corresponda garantía del suministrador anterior. Los costes por la colocación de piezas nuevas recaen sobre el comprador. Están excluidos derechos por modificaciones, aminoraciones y otros derechos de indemnización por daños y perjuicios.

Garantia PT

Para este aparelho concedemos garantia de 24 meses. A garantia cobre exclusivamente defeitos de material ou de fabricação. Peças avariadas são substituídas gratuitamente. cabe ao cliente efetuar a substituição. Assumimos a garantia unicamente de peças genuínas. Não há direito à garantia no caso de: peças de desgaste, danos de transporte, danos causados

pelo manejo indevido ou pela desatenção as instruções de serviço, falhas da instalação elétrica por inobservância das normas relativas à electricidade. Além disso, a garantia só poderá ser reinvidicada para aparelhos que não tenham sido consertados por terceiros. O cartão de garantia só vale em conexão com a fatura.

Garanti NO

Åpenbare mangler skal meldes innen 8 dager etter at varen er mottatt, ellers taper kunden samtlige krav pga slik mangel. Vi gir garanti for at våre maskiner ved riktig behandling under den rettslige garanti tidens varighet, fra overlevering, på den måten at vi erstatter kostnadsfritt hver maskindel, som innen denne tiden påviselig er ubrukelig som følge av material- eller

produksjonsfeil. For deler som vi ikke produserer selv, yter vi garanti kun i den utstrekning som garantikrav mot underleverandør tilkommer oss. Kjøperen bærer kostnadene ved montering av nye deler. Endrings- og verditapskrav og øvrige skadeerstatningskrav er utelukkede.

Takuu FI

Ilmeisistä puutteista tulee ilmoittaa kahdeksan päivän kuluessa tavaran vastaanottamisesta. Muutoin ostaja ei voi vaatia korvausta ko. puutteista. Annamme takuun oikein käsitellyille koneillemme lakisääteiseksi takuujaksi tavaran luovutuksesta alkaen siten, että vaihdamme korvauksetta minkä tahansa koneenoson, joka osoittautuu tämän ajan kuluessa käyttökelvot-

tomaksi raaka-aine- tai valmistusvirheestä johtuen. Osille, joita emme valmista itse, annamme takuun vain mikäli osien toimittaja on antanut niistä takuun meille. Uusien osien asennuskustannukset maksaa ostaja. Purku- ja vähennysvaatimukset ja muut vahingonkorvausvaatimukset eivät tule kysymykseen.

Garanti SE

Med denna maskin följer en 24 månaders garanti. Garantins täcker endast material- och konstruktionsfel. Defekta delar ersätts utan omkostningar, men kunden står för installationen. Vår garanti täcker endast original-delar. Anspråk på garanti öreligger inte för: garantin täcker ej,

transportskador, skador orsakade av felaktig behandling och då skötsel föreskrifter inte beaktats. Vidare kan garantikrav endast ställas för maskiner som inte har reparerats av tredje part.

Záruka SK

Zrejme vady musia byť predstavené v priebehu 8 dni po obdržaní tovaru, ináč zákazník stratí všetky nároky týkajúce sa takejto vady. Ponúkame záruku na naše aparáty, ktoré sú správne používané počas zákonného termínu záruky tak, že bezplatne vymeníme každú časť aparátu, ktorá sa v priebehu tohto času môže stať dokázateľne nefunkčnou dôsledkom materiálnej či

výrobnej vady. Na časti ktoré sami nevyrobíme, poskytujeme záruku iba v rozsahu, v ktorom nám prísluší nárok na záručné plnenie k subdodávateľovi. Za trovy týkajúce sa inštalácie novej súčiastky je zodpovedný zákazník. Nárok na výmenu tovaru, na zľavu a iné nároky na nahradenie škody sú vylúčené.

Garancija SI

Očitne pomanjkljivosti je potrebno naznaniti 8 dni po prejemu blaga, v nasprotnem primeru izgubi kupec vse pravice do garancije zaradi takšnih pomanjkljivosti. Za naše naprave dajemo garancijo ob pravilni uporabi za čas zakonsko določenega roka garancije od predaje in sicer na takšen način, da vsak del naprave brezplačno nadomestimo, za katerega bi se v tem roku

izkazalo, da je zaradi slabega materiala ali slabe izdelave neuporaben. Za dele, ki jih sami ne izdelujemo, jamčimo samo toliko, kolikor zahteva garancija drugih podjetij. Stroški za vstavljanje novih delov nosi kupec. Zahteve za spreminjanje in zmanjšanje ter ostale zahteve za nadomestilo škode so izključene.

Szavatosság HU

A nyilvánvaló hibákat ki kell jelenteni számított 8 napon belül az áruk, különben a vevő elveszti minden igényt az ilyen hibák. Kínálunk garanciát a gépeinket a megfelelő kezelés időtartamának hallgatólagos garancia a szállítás időpontját oly módon, hogy cserélje ki minden egyes része ezen idő alatt észlelhető a sorban anyag-vagy gyártási legyen hiábavaló, ingyen. Az alkatrészeket, hogy

nem termel magunkat, hogy csak olyan garanciát, hiszen jogosultak jótállási igények beszállítókkal szemben. A költségek beillesztése az új részek a vevőnek. Átalakítása és csökkentése követelések és egyéb kártérítési igények ki vannak zárva.

Garancija HR

Vidljive štete se moraju prijaviti u roku od 8 dana od primitka robe. U suprotnom slučaju kupac gubi pravo na reklamaciju. Mi jamčimo za naše strojeve u slučaju ispravnog postupanja tijekom perioda zakonskog jamstva tako što zamijenjujemo besplatno bilo koji dio stroja koji dokazano postane neupotrebljiv uslijed neispravnog materijala ili grešaka u proizvodnji u tom vremenskom

periodu. Za dijelove koje mi nismo proizveli jamčimo samo ukoliko imamo pravo na reklamaciju prema dobavljačima. Troškove za ugradnju novih dijelova snosi kupac. Molbe za smanjenjem cijene kao i sve druge reklamacije zbog šteta su isključene.

Záruka CZ

Viditelné vady jsou poukazatelné během 8 dní od obdržení zboží, jinak ztrácí zákazník všechny nároky týkající se takovýchto vad. Poskytujeme záruku na naše stroje, s kterými je správně zacházeno, na dobu zákonně záruční lhůty začínající od doručení tak, že bezplatně vyměníme každou část stroje, která se během této doby může stát prokazatelně nepoužitelnou následkem

materiálové či výrobní vady. Na díly, které sami neopravujeme, poskytujeme záruku pouze v rozsahu, v němž nám přísluší nárok na záruční plnění vůči subdodavateli. Náklady na instalaci nového dílu nese zákazník. Nárok na výměnu zboží, na slevu a jiné nároky na odškodnění jsou vyloučeny.

Gwarancja PL

Wszelkie uszkodzenia muszą być zgłaszane w przeciagu 8 dni od daty otrzymania towaru, w przeciwnym wypadku, prawo do reklamacji wygasa. Gwarantujemy, że w czasie trwania gwarancji wymienimy wszelkie części maszyny, które okażą się niesprawne na skutek wad materiału z jakiego zostały wykonane lub błędów w produkcji bez dodatkowych opłat pod warunkiem, że maszyna

będzie obsługiwana zgodnie z zaleceniami. W odniesieniu do części nie produkowanych przez nas, gwarancja obowiązuje tylko w przypadku naszych dostawców. Koszty instalacji nowych części są ponoszone przez klienta. Odszkodowania wynikłe z uszkodzeń maszyny oraz redukcje ceny zakupu maszyny w ramach reklamacji nie będą rozpatrywane.

Garantie RO

Defecte evidente trebuie să fie raportate în termen de 8 zile de la primirea de bunuri, altfel cumpărătorul pierde toate cererile pentru astfel de defecte. Oferim o garanție de pe mașinile noastre cu un tratament adecvat pe durata unei garanții implicite de la data de livrare în așa fel încât vom înlocui fiecare parte în acel moment detectabil într-un rând în material sau manoperă ar fi inutil, gratuit. Pentru părțile care nu ne pro-

duc, vom face doar o astfel de garanție, așa cum avem dreptul la pretenții de garanție împotriva furnizorilor. Costurile pentru introducerea de piese noi la cumpărător. Conversie și reducerea creanțe și alte cererile de despăgubire sunt excluse.

Garantii EE

Ilmselgetest vigadest tuleb teatada 8 päeva jooksul pärast kauba kättesaamist, vastasel juhul kaotab ostja kõik õigused garantiile nimetatud vigade tõttu. Õige käsitsemise korral anname oma masinatele garantii seadusega ettenähtud ajaks alates kauba üleandmisest nii, et vahetame tasuta välja kõik masina osad, mis nimetatud aja jooksul peaks muutuma kasutuskõlbmatuks

materjali- või tootmisvea tõttu. Osade eest, mida me ise ei tooda, anname garantii vaid selles osas, mis tarnija on meile garanteerinud. Uute osade paigaldamise kulud kannab ostja. Muutmis- ja amortisatsiooninõuded ning muud kahjutasunõuded välistatakse.

Garantija LV

Acīmredzami defekti ir jāpaziņo 8 dienu laikā ar precēs saņemšanas. Pretējā gadījumā pircēja tiesības pieprasīt atbildību par šādiem defektiem ir spēkā neesošas. Mēs dodam garantiju savām iekārtām, ja pircējs pret tām atbilstoši izturas garantijas laikā. Mēs apņemamies bez maksas piegādāt jebkuru rezerves daļu, kas iespējams kļuvusi nelietoājama bojātu materiālu vai ražošanas defektu dēļ šajā laika periodā. Attiecībā uz rezerves daļām, kuras nav mūsu ražotas, mēs garantējam

tikai gadījumā, ja mums ir garantija no saviem piegādātājiem. Jauno detaļu uzstādīšanas izmaksas ir jāuzņemas pircējam. Pirkuma atcelšana vai pirkuma cenas samazināšana, kā arī jebkuras citas prasības par bojājumu atbildzināšanu netiek izskatītas.

Garantija LT

Dėl akivaizdžiai matomų defektų turi būti informuota per 8 dienas nuo įrenginio gavimo momento. Kitu atveju pirkėjo teisė reikšti pretenziją dėl šių defektų yra negaliojanti. Savo įrenginiams mes garantuojame įstatymo nustatytą pilną aptarnavimą garantinio laikotarpio metu, jei yra laikomasi gamintojo-vartotojo susitarimo ir mes pažadame nemokamai pakeisti bet kurias mašinos dalis,

sugedusias dėl blogos medžiagos ar gamyklinio broko. Mes neatsakome už dalis, pagamintas ne mūsų ir jūsų gautas iš kito tiekėjo. Naujų dalių montavimo kaštai yra pirkėjo atsakomybė. Pirkimo nutraukimas ar pirkimo kainos sumažinimas, kaip ir bet kurios kitos pretenzijos dėl nuostolių nebus patenkinamos.

Abyrgð IS

Augljósar skemmdir verður að tilkynna innan 8 daga frá viðtöku vörunnar. Annars er réttur kaupanda um bætur vegna sílka skemmda ógildur. Við ábyrgjumst, í tilfelli rétttrar meðhöndlunar yfir lögbundið ábyrgðartímabil frá afhendingu, að við skiptum um hvern vélarhlut án kostnaðar sem ónothæfur er vegna gallaðs efnis eða skemmda í framleiðslu innan ákveðins tímabils. Af því er

tekur til hluti sem ekki eru framleiddir af okkur, ábyrgjumst við af því leiti aðeins að við eigum rétt á ábyrgðarkröfum gagnvart birgðasöllum. Kostnaður vegna uppsetningar á nýjum hlutum skal falla í skaut kaupanda. Ógilding sölu eða afsliáttur á kaupverði sem og aðrar kröfur vegna skemmda eru undanskildar.

Garanti TR

Apaçık kusurları malların alınmasından 8 gün içinde bildirilmesi gerekir, aksi takdirde alıcı bu kusurları için tüm talepler kaybeder. Biz ücretsiz, yarasız olmalıdır malzeme veya işçilik üst üste saptanabilir bu süre içinde her bir parça takmadan böyle bir şekilde teslim tarihinden itibaren zimmi garanti süresine uygun tedavi ile makinelerde bir garanti veriyoruz. Biz tedarıçiler karşı garanti

talepleri hakkı olarak kendimizi üretmek değil bu parça için, biz, sadece teminat olun. Alıcıya yeni parçaların yerleştirilmesi için maliyetleri. Dönüşüm ve azaltma iddiaları ve diğer tazminat talepleri dahil değildir.

гаранция BG

Очевидни недостатъци трябва да бъдат докладвани в рамките на 8 дни от получаването на стоки, в противен случай купувачът губи всякакви претенции за такива дефекти. Предлагаме гаранция на нашите машини с правилното лечение на срока на действие на косвена гаранция от датата на доставка по такъв начин, че ние замени всяка част в рамките на това време открива в един ред в материала или изработката трябва да бъде безполезно,

безплатно. За части, които ние не се произвеждат, ние правим само като гаранция, като имаме право на гаранционни искове срещу доставчици. Разходите за вмякване на нови части на купувача. Преобразуване и намаляване вземания и други искове за обезщетения, са изключени.

Гарантия RU

Об очевидных дефектах необходимо уведомить в течение 8 дней после получения товара. В ином случае все претензии покупателя по таким дефектам не принимаются. Мы предоставляем гарантию на наши машины при условии правильного обращения с ними. Гарантия действует с момента передачи машины в течение установленного законом гарантийного срока. В течение этого времени мы гарантируем бесплатную замену любой части машины, если они стали непригодны к использованию в результате доказуемых ошибок в применяемых

материалах или при изготовлении. На части машины, которые мы не изготавливаем сами, мы предоставляем гарантии в той мере, насколько нас касаются рекламационные претензии к изготовителям. Расходы по замене деталей несет покупатель. Претензии на расторжение договора купли-продажи, штрафы и прочие требования о возмещении ущерба исключаются.

Garantie BE-VLG

Zichtbare gebreken moeten binnen 8 dagen na ontvangst van de goederen worden gemeld, anders verliest de koper elk recht op aanspraak voor dergelijke gebreken. Bij een juiste behandeling van onze machines en gedurende de wettelijke garantietermijn vanaf de aflevering bieden wij garantie door elk machineonderdeel, dat tijdens deze periode door materiaal- of

productiefouten onbruikbaar zou worden, gratis te vervangen. Voor onderdelen die wij niet zelf produceren, bieden wij enkel garantie in de mate die de toeleveranciers ons bieden. De kosten voor de plaatsing van de nieuwe onderdelen draagt de koper. Aanspraken voor wijzigingen, waardevermindering en overige schadeloosstelling zijn uitgesloten.