



Manuel d'utilisation et d'entretien
(Notice originale)

Instruction and maintenance manual
(Translation of the original note)



PERFORM

3000 XL TB UK C5

KOHLER[®]
SDMO[®]

CE

33522201001_1_1

11/2019

B

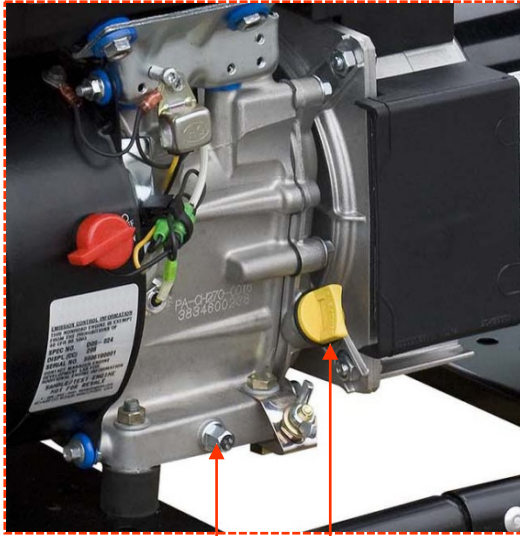

5

1

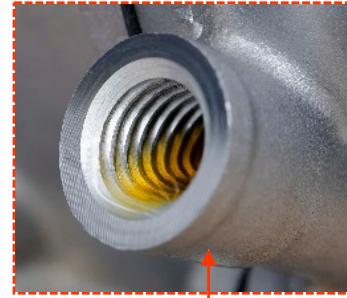

2

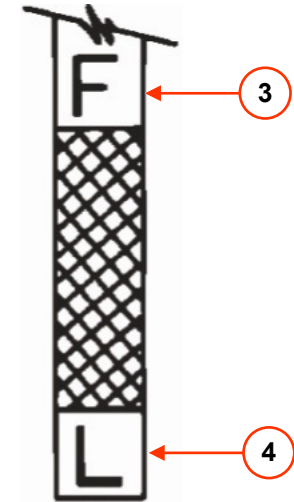

3

4

C

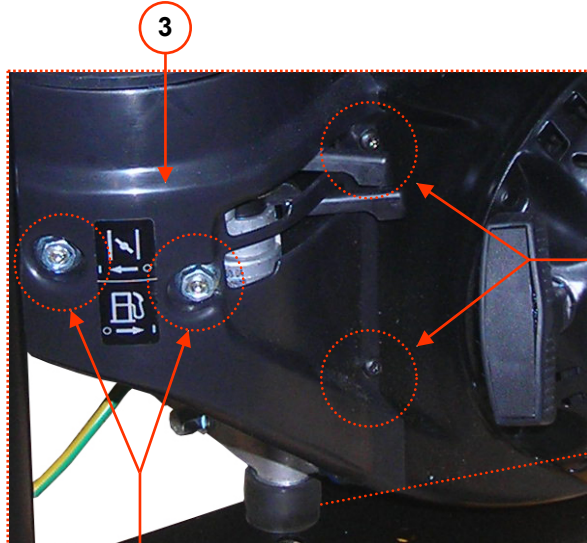

3

4

5

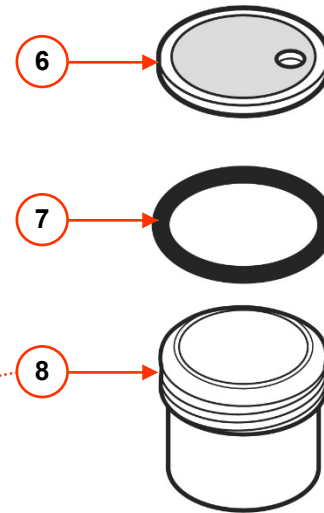

6

7

8

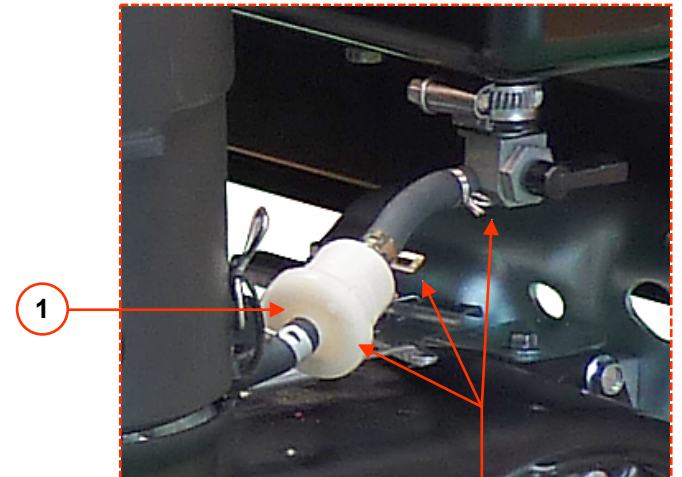

1

2

D

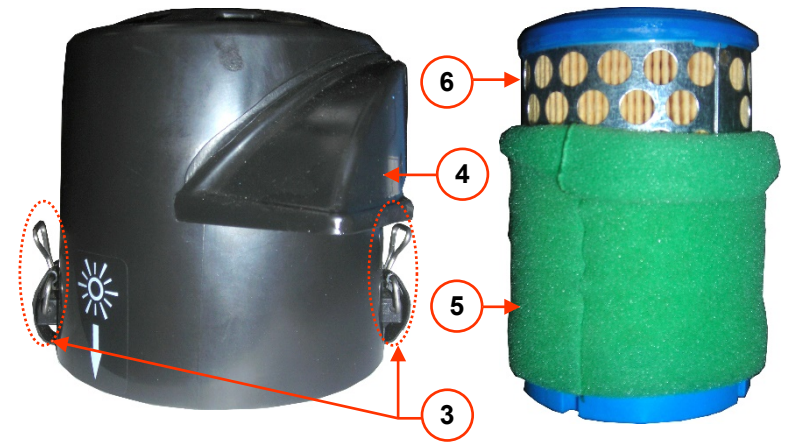
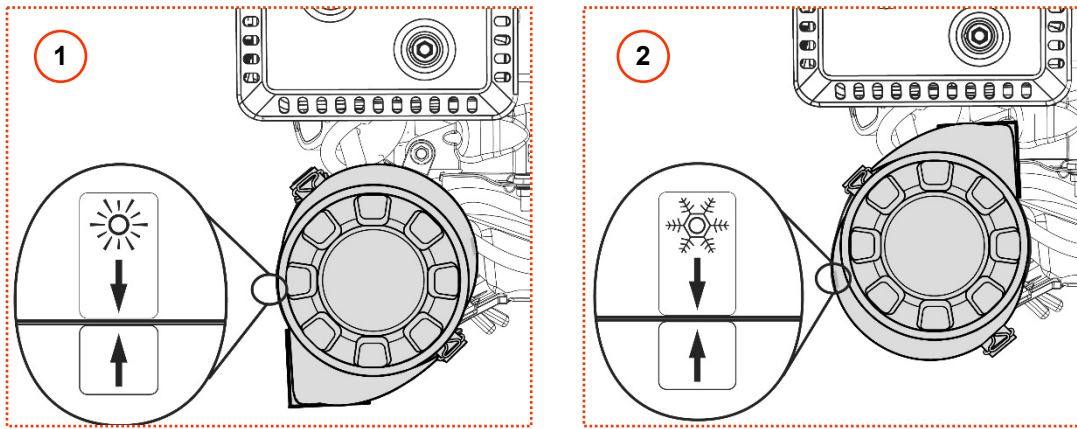

E

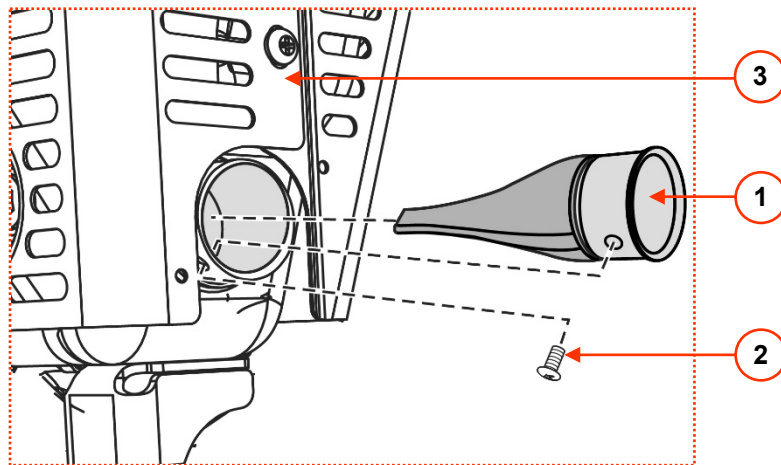

F

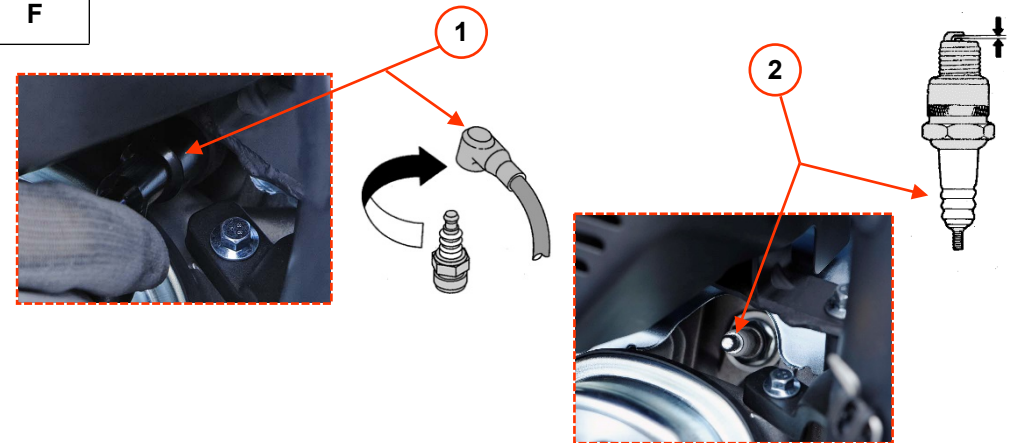

KOHLER[®]
SDMO[®]

FRANCE:
0.806.800.107 (Prix appel)

1..Preface
 2..Instructions and safety regulations (personal protection)
 3..Getting started with the generating set
 4..Using the generator set
 5..Generating set maintenance

6..Transporting and storing the generating set
 7..Repairing minor faults
 8..Technical specifications
 9..Conditions of warranty

1 Preface

IMPORTANT	Material damage Before use, read this manual and the safety instructions provided alongside it thoroughly. Keep these safe throughout the unit's service life and always adhere to the safety advice and the usage and maintenance instructions contained therein.

The information contained in this manual is taken from technical data available at the time of print (the photos shown in this manual are not legally binding). In line with our policy of continually improving the quality of our products, this information may be amended without warning. On request, we can supply our original manuals in French via our website.

In this manual, dangers are represented by the following two symbols:

DANGER	RISK TO THE HEALTH OF THOSE CONCERNED DANGER OF DEATH (if appropriate) Indicates an imminent danger which may result in death or serious injury. Failure to follow the instruction shown may pose serious risks to the health and life of those concerned.
[Appropriate pictogram(s)]	

IMPORTANT	Material damage [At-risk equipment] Indicates an at-risk situation. Failure to follow the instructions provided may result in minor injuries to those concerned or material damage.

2 Instructions and safety regulations (personal protection)

The instructions and safety regulations must be read carefully and followed to avoid endangering personal health and safety. If there is any doubt over the meaning of the instructions, please contact your nearest agent.

2.1 Meaning of the pictograms on the generating set

 DANGER	 DANGER: risk of electric shock	 GROUND	 DANGER: risk of burns	 Before starting, check the oil level.
				DANGER: 1 - Refer to the documentation supplied with the unit. 2 - Emission of toxic exhaust gases. Do not use in a confined or poorly ventilated area. 3 - Stop the unit before filling with fuel.



2.2 General guidelines

Never let other people use the unit without ensuring they have all of the necessary instructions beforehand. Never allow a child to touch the unit, even when switched off, and do not operate the unit when animals are in the vicinity (fear, disturbance, etc.). In all cases, respect the local regulations currently in place concerning the use of the units. Exhaust gases, fuel and oil are toxic products; take all necessary protective measures.

2.3 Guidelines for protecting the environment



Drain the engine oil into a designated container: never drain or discard engine oil onto the ground. As far as possible, avoid sound reverberating through walls or buildings (the noise will be amplified). If the unit is used in wooded, bushy or uncultivated areas and if the exhaust silencer is not fitted with a spark arrester, clear any vegetation away from the area and take care that the sparks do not cause a fire. Once the unit is no longer being used (end of product life), take it to a waste collection point.

2.4 Risks relating to exhaust gases

 DANGER	<p>RISK OF POISONING DANGER OF DEATH (if appropriate) The carbon monoxide present in the exhaust gas may lead to death by inhalation if the concentration levels in the atmosphere are too high. Always use the unit in a well ventilated area where the gases cannot accumulate.</p>
	

For safety reasons and for correct operation of the unit, correct ventilation is essential (risk of poisoning, engine overheating and accidents involving, or damage to, the surrounding equipment and property). If it is necessary to operate it inside a building, the exhaust gases must be evacuated outside and adequate ventilation must be provided so that any people or animals present are not affected.

2.5 Risk of fire



 DANGER	<p>RISK OF FIRE DANGER OF DEATH Never operate the unit in areas containing flammable products (risk of sparks). Keep all flammable or explosive materials (e.g. petrol, oil, cloth, etc.) out of the way when unit is running. Never cover the unit with any type of material while it is in operation or just after it has been turned off: always wait until the engine cools down (at least 30 minutes).</p>
	

2.6 Risk of burns

IMPORTANT	<p>Before any intervention, wait for the unit to cool down (at least 30 minutes).</p>
	

When running and just after stopping, the oil, engine and the exhaust silencer are hot and may cause burns if contact is made.

2.7 Risk of electrocution

 DANGER	<p>RISK OF ELECTROCUTION DANGER OF DEATH Units supply electrical current while operating; comply with the applicable legislation as well as the installation and usage recommendations given in this manual. If you are in any doubt regarding installation, please contact your nearest agent. Do not connect the unit directly to other power sources (such as the mains for example); fit a source changeover panel. Never touch stripped cables or disconnected connectors. Never handle a unit with wet hands or feet. Never expose the equipment to liquid splashes or rainfall, and do not place it on wet ground.</p>
	

2.7.1 Temporary or semi-temporary installation (work site, show, fairground, etc.)

- A - If the unit is not equipped with an integrated differential protection device at delivery (standard version with insulated neutral on the unit's earth terminal):
- Use a differential device calibrated to 30mA at the output of each of the unit's sockets (place each device at least 1 metre from the unit, protecting it from weather conditions).
 - If one or more mobile or portable devices are used occasionally, the unit does not need to be earthed.
- B - If the unit is equipped with an integrated differential protection device at delivery (standard version with alternating neutral connected to the unit's earth terminal - for use with TT or TN systems):
- Connect the unit to the earth: attach a 10 mm² copper wire to the unit's earth terminal (A1) and to a galvanised steel earthing rod set 1 metre into the ground.

2.7.2 Fixed installation or mains failure

When supplying a fixed installation (e.g. as backup for mains outages), the unit must be connected by a qualified electrician in accordance with the regulations applicable at the installation site. The units are not designed to be connected directly to an installation (risk of electrocution or damage to equipment).

- A - If the unit is not equipped with an integrated differential protection device at delivery (standard version with insulated neutral on the unit's earth terminal):
- Use a source inverter.
 - The unit does not need to be earthed.
- B - If the unit is equipped with an integrated differential protection device at delivery (standard version with alternating neutral connected to the unit's earth terminal - for use with TT or TN systems):
- Use a source inverter.
 - Connect the unit to the earth: attach a 10 mm² copper wire to the unit's earth terminal (A1) and to a galvanised steel earthing rod set 1 metre into the ground.

2.7.3 Mobile application

The units are intended to operate while stationary. They may not be installed on a vehicle or other mobile equipment unless a study has been carried out analysing the unit's various installation and usage specifications. It is prohibited to use the unit whilst it is in motion. If earthing is not possible, connect the unit's earth terminal (A1) to the vehicle earth.

2.7.4 Connection and choice of cables

For all connections, use flexible, strong rubber-sheathed cables which comply with standard IEC 60245-4 or equivalent cables, and ensure that these are kept in perfect condition. Only use one item of class I electrical equipment per socket and connect up equipment using a cable equipped with a PE protective conductor (green/yellow); this protective conductor is not required for class II equipment. Adhere to the cross sections and lengths recommended in this table during installation or when using electrical extensions.

Equipment type:		Single-phase						Three-phase			
Type of unit connector:		10 A		16 A		32 A		10 A		16 A	
Recommended cable cross section:		mm ²	AWG	mm ²	AWG	mm ²	AWG	mm ²	AWG	mm ²	AWG
Length of cable used	0 to 50 m	4	10	6	9	10	7	1.5	14	2.5	12
	51 to 100 m	10	7	10	7	25	3	2.5	12	4	10
	101 to 150 m*	10	7	16	5	35	2	4	10	6	9

*This cable length is the maximum permitted length, and must not be exceeded.

Installation method = cables on raceway or non-drilled tablet/Permitted drop in voltage = 5%/Multi-core conductors/Cable type PVC 70°C (e.g. H07RNF)/Ambient temperature =30°C.

2.8 Risk of hearing loss

	<p>RISK OF HEARING LOSS Suitable hearing protection must be worn at all times when the unit is running.</p>

2.9 Risks during handling operations, use and maintenance

For safety reasons, all operations must be carried out by staff with the necessary skills and using suitable equipment. Maintenance must be carried out on a regular and conscientious basis, using only original parts. Gloves must be worn.



Safety guidelines for handling petroleum products:

	<p>RISK OF POISONING OR EXPLOSION Respect the local regulations in force concerning the handling of petroleum products. Fill up when the unit is switched off and the engine cold. Smoking, using a naked flame, producing sparks and making telephone calls are forbidden when filling the tank. After filling, always check that the tank's filler cap is properly tightened. Clean any traces of fuel with a clean cloth and wait until the vapors have dispersed before starting the unit. If the fuel is exposed to high temperatures for a period of several hours (containers or generating set stored in a vehicle parked in the sun, for example), harmful vapors could be released causing a risk of poisoning or of feeling unwell. The fluids used by the units, such as oils and fuels, are dangerous products. Never inhale or ingest; avoid prolonged or repeated contact with the skin.</p>

Safety guidelines for handling batteries:

	<p>RISK OF POISONING OR EXPLOSION Follow the battery manufacturer's recommendations. Only use insulated tools. Keep away from fire or naked flames. Always ensure adequate ventilation during charging.</p>

3 Getting started with the generating set

3.1 Key to illustrations

The cover illustrations can be used to identify the various components of the generating set. The procedures in the manual refer to these illustrations using letters and numbers as identifiers: "A1" refers to the number 1 on figure A.

Earth terminal	A1	Starter-recoil reel handle	A9	Air filter cover attachment	D3
Oil dipstick/filler plug	A2-B1	Electrical sockets	A11	Foam element	D5
Filler neck	B2	Voltage selector	A10	Paper element	D6
Dipstick upper limit	B3	Oil drain screw	A12-B5	Exhaust silencer	A15
Dipstick lower limit	B4	Fuel filter	A13-C1	Spark arrester	E1
Fuel level indicator	A3	Fuel filter retaining clips	C2	Spark arrester mounting bolt	E2
Fuel tank cap	A4	Sediment bowl	A14-C8	Exhaust silencer protection	E3
Fuel taps	A5	Cover mounting bolt	C4	Spark plug	A16-F2
Air filter	A6	Cover mounting nut	C5	Spark plug cap	F1
"Normal" position	D1	Cover	C3	Circuit breakers	A17
"Low temperatures" position	D2	Sediment bowl cover	C6	GSC101-Generator Smart Care	A18
Switch	A7	Sediment bowl seal	C7		
Choke	A8	Air filter cover	D4		

The unit may be equipped with the "GS101-Generator Smart Care" option (A18): the Bluetooth GSC101 box transmits all the information needed to monitor the unit to an application to be installed on your mobile phone; this includes maintenance dates, a maintenance aid, and the map of approved resellers for any spare parts required.



3.2 Initial commissioning

On taking delivery and commissioning the unit:

1. Check that it is complete and not damaged in any way.
2. If the unit is fitted with a transport bracket, remove it.
*The transport bracket is a metal plate located underneath the engine, close to the earth terminal. Although useful for transportation, it will prevent optimum operation of the unit (noise, vibration).
To remove it: lift the unit slightly and place it on a block then remove the nut (1) and the clamp (2).*
3. Check the oil and fuel levels and top them up if necessary.
4. If necessary, connect the battery, starting with the positive terminal.
Observe the polarity of the battery terminals when connecting it: as this could cause serious damage to the electrical equipment.

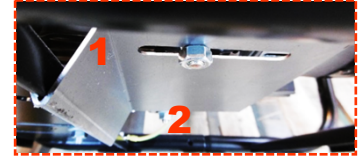

Some units require a running-in period. Contact your nearest agent for more information.

3.3 Installing Generator Smart Care (Option)

The unit may be equipped with the "GS101-Generator Smart Care" option (A18):

1. Secure the Bluetooth GSC101 box to the unit,
2. Download and install the free Generator Smart Care* application onto a mobile phone or tablet,
3. Create an account,
4. Activate Bluetooth on the phone or tablet,
5. Follow the instructions on the application to pair the phone or the tablet with the Bluetooth GSC101 box.

Generator Smart Care displays all the information needed to monitor the unit in the application; this includes maintenance date alerts and reminders, a maintenance aid, and the map of approved resellers for any spare parts required.



**Available free from the App Store and Google Play (excluding any connection fees charged by the phone system operator).*

4 Using the generator set

Before using the unit, always:

1. Check that the unit is correctly installed and that it is ready to start.
2. Make sure you have understood all of the operating procedures.
To stop the unit in an emergency: turn the key to the "OFF" position and close the fuel tap(s), if fitted.

4.1 Positioning the generating set for operation

 DANGER	RISK OF POISONING - CARBON MONOXIDE DANGER OF DEATH (if appropriate) Carbon monoxide is invisible, odorless and non-irritating and can cause death in less than an hour. Always use the unit in a well ventilated area where the gases cannot accumulate. In the event of headache, nausea or vomiting: stop the unit immediately, ventilate and evacuate the area and call for help.
	

1. Choose a site that is clean, well ventilated and sheltered from bad weather.
2. Position the unit on a flat horizontal surface that has sufficient load-bearing capacity to prevent it from sinking.
The units are designed for stationary operation: they must not be installed on a vehicle or other mobile equipment unless a study taking into account the different specific requirements for use of the unit has been carried out.
3. Check that the angle of the unit, in all directions, does not exceed 10°.

4.2 Check the generating set is in a good general condition (bolts, hoses)

Inspect the entire unit before start-up and after each use to prevent any faults or damage.

1. Check that the unit is clean, in particular the air intake zones (engine air intake, air vents, air filter, etc.).
2. Check all of the unit's pipes and hoses to ensure they are in good condition and that there are no leaks.
Pipes or hoses must be replaced by a specialist technician. Please contact your nearest agent.
3. Tighten any loose bolts.
The cylinder head bolts must be retightened by a specialist technician. Please contact your nearest agent.

4.3 Checking the engine oil level and topping up

1. If the unit has been used, leave to cool for at least 30 minutes
2. Remove the oil dipstick/filler plug (A2-B1) by unscrewing it, and wipe the dipstick.
3. Insert the oil dipstick/filler plug in the filler neck (B2) without tightening it, then take it out again.
4. Visually check the level: it must be between the upper limit (B3) and lower limit (B4) on the dipstick.
*If the oil level is too low: open the oil filler cap, use a funnel to top up the tank (using oil that complies with the specifications in the manual), then screw the oil filler plug back in.
If the oil level is too high: drain some of the oil into a suitable container.*
5. Check the level again before screwing the oil dipstick/filler plug back in fully.
6. Check that there are no oil leaks, and wipe away any traces of oil with a clean cloth.

4.4 Checking the fuel level and topping up

With the unit on a flat, level surface, visually inspect the fuel level on the indicator (A3): the red marker on the indicator should be between the maximum level (F = full) and the minimum level (E = empty). If necessary, fill with fuel:

1. Unscrew the fuel tank cap (A4).
2. Fill the fuel tank using a funnel, taking care not to spill any fuel and checking the level at regular intervals: the fuel level indicator must be at position "F".
Do not overfill the tank; there should not be any fuel in the filler neck.
3. Carefully tighten the fuel tank cap.
4. All traces of fuel should be wiped off with a clean cloth.

4.5 Starting the generating set

Once the daily checks have been performed, and having read the instructions and safety regulations carefully:

If the outdoor temperature is above 0°C:

1. Open the fuel tap (A5).
2. Check that the air filter is in the normal position for use (D1).
3. If the generating set is cold, move the choke control (A8) to position "I".
4. Move the switch (A7) to "ON" or "I".
5. Slowly pull the starter-recoil reel handle (A9) until there is some resistance, then let it return gently.
6. Then pull the starter-recoil reel handle quickly and sharply until the unit starts.

If the unit does not start, wait one minute before repeating the process no more than three times.

If the outdoor temperature is below 0°C:

1. Open the fuel tap (A5)
2. Place the air filter in the "low temperature" position (D2).
3. Move the choke control (A8) to position "I".
4. Move the switch (A7) to "ON" or "I".
5. Slowly pull the starter-recoil reel handle (A9) until there is some resistance, then let it return gently.
6. Then pull the starter-recoil reel handle quickly and sharply until the unit starts.

If the unit does not start, wait one minute before repeating the process no more than three times.

4.6 Using the electricity supplied

1. Allow the unit speed to stabilise and the temperature to rise (approx. 3 to 5 min.).
2. If the choke (A8) was used, return it gradually to its original position.
3. Connect the equipment to be used to the electrical sockets (A11) on the unit.
4. Place the voltage selector (A10) in the position corresponding to the voltage you need to use (115V or 230V).

4.7 Switching the generating set off

1. Disconnect the equipment used, taking care to close the cover for the unit's electrical sockets (A11).
2. Allow the unit to run idle for 1 or 2 minutes.
3. Set the switch (A7) to "OFF" or "O": the unit will shut down.
4. Close the fuel taps (A5).
5. Ensure the unit is properly ventilated and to avoid any risk of fire, wait for it to be fully cool (at least 30 minutes) before covering it and storing it.

Even when the unit is turned off, the engine continues to give off heat.

5 Generating set maintenance

As a safety measure, maintenance should be performed on the generating set regularly and carefully by people who have the necessary experience and are equipped with suitable tools, in respect of current regulations. The maintenance operations to be carried out are detailed in the maintenance table. The interval for this is supplied as a guide and for generating sets operating with fuel and oil which conform to the specifications given in this manual. The maintenance intervals can be shortened depending on the generating set's operating conditions and requirements. It is important to note that the warranty shall not be valid if generating set maintenance has not been performed correctly.

5.1 Reminder of use

Ensuring maintenance is performed regularly and correctly will guarantee safety and performance. **The oil, filter elements and, where present, the spark plug, are consumables which must be in good condition for the unit to operate correctly. Replace them regularly as often as is needed (the reference for ready-to-use maintenance kits is given in the table of technical specifications where applicable).** The warranty becomes void in the event of failure to respect the maintenance recommendations. For any questions about a special operation, please contact your nearest agent who will advise and help you.

5.2 Maintenance intervals table

The maintenance frequency is given as an indication only and is for devices using fuel and oil complying with the specifications given in this manual. The maintenance intervals can be shortened depending on the unit's operating conditions and requirements. Perform the maintenance operations at the indicated due dates even if the number of hours' operation has not been reached. **The warranty will be invalidated if maintenance of the unit has not been performed correctly.**

Operation to be carried out:		After		In hours, months or years, whichever comes first			
		5 hours	3 months/ 50 hours	Every 3 months/ 50 hours	Every 6 months/ 100 hours	Every 1 year/ 200 hours	Every 2 years/ 500 hours
Unit	Clean the unit		X		X	Major service to be carried out by one of our agents. France: 0.806.800.107 (call charge)	Major service to be carried out by one of our agents. France: 0.806.800.107 (call charge)
	Clean the spark arrester				X		
	Replace the spark plug				X		
Oil	Change	X	X		X		
Fuel	Replace the fuel filter				X		
	Clean the sediment bowl				X		
Air filter	Clean	X	X	X	X		
	Replace				X		
<i>Part numbers of parts to be used during maintenance:</i>					RKS1		

5.3 Performing the maintenance operations

1. Shut down the unit and wait at least 30 minutes for it to cool.
2. Disconnect the cap(s) of the spark plug(s) and disconnect the "-" terminal on the battery (if fitted).
3. Carry out maintenance in accordance with the information given in this manual and, to avoid the risk of damage to the unit, only use original parts or their equivalent.

5.3.1 Drain the engine oil

To ensure that the oil service is performed quickly and correctly, the oil must be changed when the engine is warm (start the unit and allow it to run for a few minutes if necessary).

1. Place a suitable container under the oil drain screw (A12-B5), then remove the oil dipstick/filler plug (A2-B1) and the oil drain screw.
2. After draining completely, carefully refit the oil drain screw.
3. Use a funnel to top up with oil (using oil which complies with the specifications given in this manual), and regularly check the level.
The oil level must be between the minimum and maximum marks on the dipstick. If the oil level is too low, keep topping it up. If the oil level is too high, drain some off.
4. Refit and tighten the oil dipstick/filler plug.
5. Wipe away any traces of oil with a clean cloth and check that there are no leaks.

5.3.2 Clean the sediment bowl.

1. Close the fuel tap (A5).
2. Unscrew the cover retaining screws (C4) and nuts (C5).
3. Remove the cover (C3).
4. Unscrew the sediment bowl (A14-C8).
5. Use clean fuel to clean the sediment bowl, then dry it completely.
6. Check that the cover (C6) and seal (C7) for the sediment bowl are in good condition: replace them if they are damaged.
7. Screw the sediment bowl back on.
8. Refit the cover and carefully tighten its mounting screws and nuts.
9. Open the fuel tap and check that there are no leaks.
10. All traces of fuel should be wiped off with a clean cloth and the fuel tap closed again.

5.3.3 Replace the fuel filter

1. Close the fuel taps (A5).
2. Note the direction of assembly for the fuel filter (A13-C1).
3. Place a suitable container underneath the fuel filter and undo the two clips (C2).
The fuel filter is removed.
4. Observing the direction of fitting, fit a new fuel filter and secure it using the two clips.
5. All traces of fuel should be wiped off with a clean cloth and the fuel taps opened.
6. Check that there are no leaks then close the fuel taps again.

5.3.4 Clean or replace the air filter

IMPORTANT	
	Risk of fire or explosion: for a foam element, only use soapy water and clean engine oil during this operation.

If the filter elements are excessively dirty or damaged (torn, pierced), it is essential to replace them with new elements and at least every 3 cleaning procedures.

1. Unlock the air filter cover (D4 & D3) and remove it.
2. Remove the filter elements (D5 & D6) for cleaning.
3. Clean the foam element: wash it in soapy water, carefully rinse it and leave it to dry completely.
4. Soak the foam element in a little clean engine oil and squeeze it to remove any excess oil (do not wring it out).
If there is too much oil remaining in the foam, the unit will emit smoke when it is first started.
5. Replace the paper element.
6. Refit the filter elements, then refit the air filter cover and lock it.

5.3.5 Replace the spark plug.

1. Disconnect the spark plug cap (F1).
2. Use a dry air spray to clean the spark plug wells.
3. Use a spark plug spanner to unscrew the spark plug (A16-F2) and discard it.
4. Fit a new spark plug in position and tighten it by hand to avoid damaging the threads.
5. Use a spark plug spanner to tighten the spark plug by 1/2 turn after it is seated to compress the washer.

5.3.6 Cleaning the spark arrester

1. On the exhaust silencer, unscrew the spark arrester mounting bolt (E2).
2. Remove the spark arrester (E1).
3. Using a wire brush, remove the carbon deposits from the spark arrester screen.
4. Check that the spark arrester is in good condition (no holes or cracks), and replace it if necessary.
5. Refit the spark arrester on the exhaust silencer protection (E3) and retighten the spark arrester mounting bolt.

5.3.7 Cleaning the generating set

To ensure it continues to run correctly, the unit must be cleaned regularly. If the unit is installed inside, always check that the installation is clean and in good condition. If the unit is being used outside (building sites, dusty, muddy or densely wooded areas, corrosive environment, etc.), it must be cleaned more frequently.

Use of water sprays or high pressure cleaning equipment is prohibited as this may seriously damage the unit.

1. Use a brush to gently clean the engine air intakes and outlets and, if present, the spark arrester.
2. Clean the unit with a sponge and water mixed with a mild detergent (car shampoo, for example), then rinse with fresh water to remove all traces of the cleaning product.
A cleaning foam may be used and wiped off using a soft, absorbent cloth. Stubborn stains may be removed using a suitable solvent (white spirit or equivalent) and wiped off using a soft, absorbent cloth.
3. Check the general condition of the unit (no leakage, tightness of nuts and bolts, connections and hoses, etc.)
4. Apply an anti-rust product to damaged areas, change defective parts and damaged labels if necessary.
Only use original parts and consult an agent if necessary.

6 Transporting and storing the generating set

6.1 Transport and handling conditions

The unit should be handled gently and sudden movements should be avoided. Ensure that the place where it is to be stored or used is carefully prepared beforehand. Before any fixed installation on a trailer or inside a vehicle, consult one of our approved agents.

Before transporting the unit, take the following necessary precautions:

1. Check that the routes to be used are smooth and drivable. If it proves necessary to use uneven roads, drain the fuel into a container before setting off.
2. Check that the bolts are correctly tightened, close the fuel tap (if fitted) and disconnect the battery (if fitted).
3. The unit should always be transported in its normal operating position; never lay it on its side. Ensure that the unit cannot fall from the vehicle carrying it, but without exerting too much force (risk of damaging the unit).

6.2 Storage conditions

This procedure for storing the unit or protecting it over the winter must be respected if it is not used for a period of up to 1 year. For longer periods of storage, it is recommended to contact your nearest agent or to start up the unit for a few hours every year, ensuring that the storage procedure is respected afterwards.

Drain the fuel and change the engine oil:

1. Start the unit and allow it to operate until it runs out of fuel.
2. Set the switch to OFF (A7).
3. Clean the sediment bowl.
4. Close the fuel taps (A5).
5. Top up the oil.

Grease the cylinder and valves:

6. Remove the spark plug (A16-F2) then, via its aperture, pour in approx. one teaspoon of new engine oil.
7. Refit a new spark plug in its place.
8. Pull the starter-recoil reel handle (A9) several times to distribute the oil inside the cylinder.

Storing the unit:

9. Clean the unit.
10. Cover it with a protective cover and store it in its normal position, in a clean, dry and well ventilated area.

7 Repairing minor faults

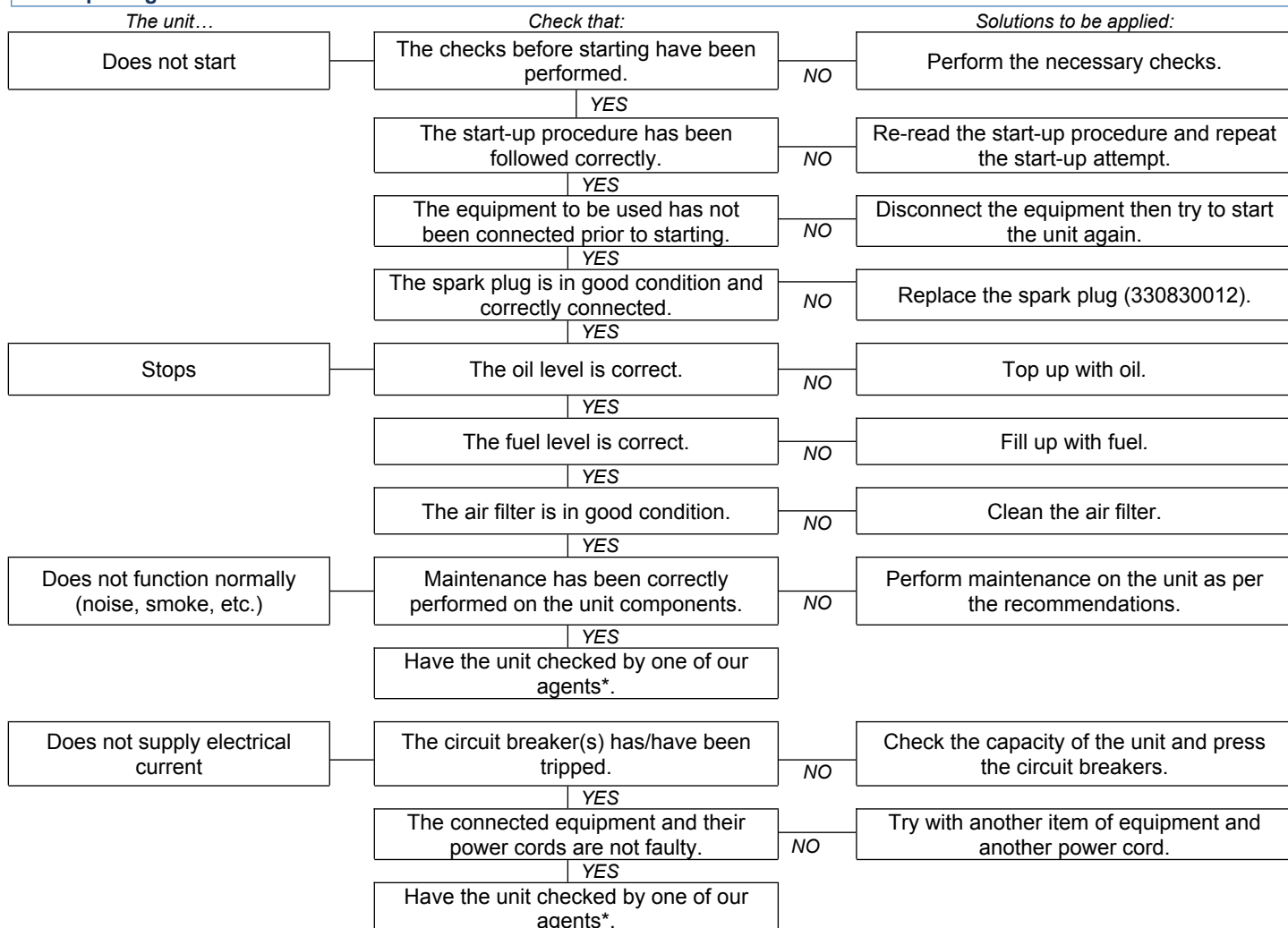

*France: 0.806.800.107 (call charge).

7.1 Generator Smart Care (Option)

If the unit has been equipped with the "GS101-Generator Smart Care" option (A18), it is necessary to change the batteries in the Bluetooth GSC101 box when the warning is displayed in the Generator Smart Care application (approximately every two years).

1. Use a small crosshead screwdriver to open the cover of the box,
2. Remove the used batteries and take them to a waste collection point so that they can be recycled,
3. Fit two new AAA batteries, observing the polarity (+/-),
4. Close the unit cover and carefully tighten the screws.



8 Technical specifications

8.1 Operating conditions

The stated outputs of the units are obtained under the reference conditions outlined in ISO 8528-1(2005):

Total barometric pressure: 100 kPa - Ambient air temperature: 25°C (298 K) - Relative humidity: 30%.

The unit's output is reduced by approximately 4% for every additional 10°C and/or approximately 1% for every additional 100m in altitude. Units can only operate while stationary.

8.2 Capacity of the generating set

Before connecting and operating the unit, calculate the electrical power required by the units to be used (in watts)*. To ensure optimal operation, the total wattage of all equipment used at the same time must be:

- greater than 60% of the rated load for the unit (risk of insufficient load);
- less than the rated load for the unit during continuous operation (risk of overload).

If the unit is run under or over its rated load frequently or for long periods of time, it can start to wear very quickly. Damage caused in this way will not be covered by the warranty.

*This load is usually indicated in the technical specifications or on the manufacturer's plate for the equipment. Some equipment requires a higher load when starting. This minimum required power must not exceed the unit's maximum power.

8.3 Generating set identification

The identification plate for the unit (example shown below) is affixed inside one of the skirts or on the chassis.

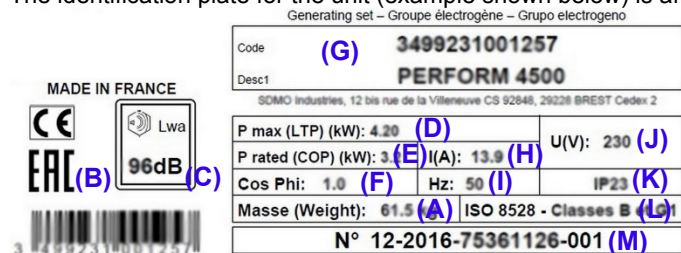

- | | |
|--------------------------------------|-------------------------|
| (A): Model | (G): Ground |
| (B): CE/EAC marking | (H): Current amperage |
| (C): Guaranteed acoustic power level | (I): Current frequency |
| (D): Maximum power | (J): Current voltage |
| (E): Nominal power | (K): Protection rating |
| (F): Power factor | (L): Reference standard |
| | (M): Serial number |

Serial numbers will be required when requesting troubleshooting advice or spare parts. For your records, please enter the unit and engine serial numbers below.

Unit serial number:/..... -	Engine manufacturer:(e.g. Kohler)	Engine serial number: (e.g Kohler (SERIAL NO. 4001200908))
--	-----------------------------------	---

8.4 Specifications

Model	PERFORM 3000 XL TB UK C5
Maximum power	2800 W
Rated output	2400 W
Acoustic pressure at 1 m	81 dB(A)
Acoustic measurement uncertainty	0,47 dB(A)
Engine type	CH270_C5
Maintenance kit	RKS1
Fuel tank capacity	13 L
Recommended fuel	Unleaded petrol
Recommended oil	10W30
Oil sump capacity	0,60 L
Oil cut-out*	O
Direct current	X
Alternating current	230V-10.4A
Circuit breaker(s)**	O
Socket type	2x2P+T -115V-16A + 1x2P+T-230V-16A
Spark plug type	330830012
Battery	x
Dimensions l x w x h	65 x 51 x 54 cm
Weight (without fuel)	47,5 kg

o: standard x: not available

*Oil cut-out: If there is no oil in the engine sump or if the oil pressure is low, the oil cut-out mechanism automatically stops the engine to prevent any damage. If this occurs, check the engine oil level and top it up if necessary before looking for any other cause of the problem.

**Circuit breaker: The generating set's electrical circuit is protected by one or more magnetothermal, differential or thermal cut-out switches. In the event of an overload and/or short circuit, the supply of electrical energy may be cut. If necessary, replace the circuit breakers in the generating set with circuit breakers with identical nominal ratings and specifications.

8.5 Recommended fuel quality

Using fuel which does not comply with the following specifications exposes the equipment to irreversible damage not covered under warranty:

- Cleanliness and quality: ensure that the petrol used does not contain water and that it is fresh and clean (not out of date or contaminated). For the
- Octane rating: minimum octane rating of 87 (R+M)/2 or minimum octane rating of 90 (RON = Research Octane Number)
- Blends: the use of unleaded petrol containing up to 10% ethyl alcohol is authorised (France: SP95-E10). It is not permitted to use unleaded petrol containing less than 90% petrol, e.g. E15, E20 or E85. Blends of methyl tert-butyl ether (MTBE) and unleaded petrol are approved (up to a maximum of 15% MTBE by volume).

However, it is strongly recommended that the same type of fuel is used throughout the complete service life of the unit. If the unit is used infrequently (less than once a month), use new fuel with each use or add a stabilizing additive to the fuel tank.

8.6 EC Declaration of conformity

We, SDMO Industries - 270 rue de Kerervern, 29490 GUIPAVAS/CS 40047, 29801 BREST CEDEX 9 – France, hereby declare under our sole responsibility that the following generating sets:

Equipment description:	Make:	Trade name:	Type:	Serial numbers:
Generating set	KOHLER-SDMO	PERFORM 3000 XL TB UK C5	3499231003572	09-2019-00000000-000 > 52-2026-99999999-999

1. Comply with the safety requirements set out in the Low Voltage Directive - **2014/35/EU** of 26 February 2014 in application of the harmonized standard EN ISO 8528-13: 2016
2. Comply with the provisions of the following Directives:
 - Machinery - **2006/42/EC** of 17th May 2006 in application of the harmonized standard EN 8528-13: 2016
 - Electromagnetic compatibility - **2014/30/EU** of 26th February 2014 in application of the harmonized standards EN 60034-1: 2010 (COR 2010) / EN 61000-6-1: 2007 / EN 61000-6-2: 2005 (COR 2005) / EN 61000-6-3: 2007 (AMD1 2011, AMD1/COR 12) / EN 55011: 2009 (AMD 1 2010)
 - Relating to the restriction of the use of certain hazardous substances in electrical and electronic equipment (RoHS2) - **2011/65/EU** of 8th June 2011 (from 23rd July 2019) in application of the harmonized standard EN 50581: 2013
 - Relating to noise emission in the environment by equipment for use outdoors- **2000/14/EC** of 8 May 2000, via the compliance procedure set out in Annex VI:

Notified body:	Measured sound power level:	Guaranteed sound power level (LwA):	Rated output:
CETIM, BP 67- F60304 – SENLIS – FRANCE	94,86 dB(A)	95 dB(A)	2400W

Name and address of the person authorized to create and hold the technical file:

L. ANDRIEUX, 270 rue de Kerervern, 29490 GUIPAVAS / CS 40047, 29801 BREST CEDEX 9 – France.

GUIPAVAS, 11/2019

L. ANDRIEUX
President, SDMO Industries



9 Conditions of warranty

COMMERCIAL WARRANTY

Your unit is covered by a commercial warranty granted by *SDMO Industries*. This warranty must be applied by the distributor from which you purchased your unit, in accordance with the following provisions:

TERM:

The warranty for your unit is valid for a period of 36 months or 2000 operating hours, from the date of purchase. It applies to whichever of these thresholds is reached first. If the unit does not have a working hours counter, the number of operating hours will be deemed to be eight (8) hours per day.

TERMS FOR APPLICATION OF THE WARRANTY:

The warranty starts on the date the unit was purchased by the first user. This warranty is transferred with the unit if the first user chooses to transfer it, either free or for a charge; it is valid for the remaining duration of the initial warranty, which cannot be extended.

The warranty only applies upon presentation of a legible purchase invoice, which states the date of purchase, the unit type, the serial number, and the name, address and commercial stamp of the distributor. *SDMO Industries* reserves the right to refuse to honour the warranty in the absence of documentary evidence of the date and place of purchase of the unit. This warranty entitles the holder to the repair or replacement of the unit or its components, if deemed to be defective by *SDMO Industries* after expert analysis in its workshops; *SDMO Industries* reserves the right to modify the equipment on the unit to meet its obligations. The unit or components replaced under warranty become the property of *SDMO Industries*.

LIMITATION OF THE WARRANTY:

The warranty applies to units installed, used or maintained in accordance with the documentation provided by *SDMO Industries*, and in the event of any operating defect with the unit, caused by a fault with the design, manufacture or material. *SDMO Industries* does not guarantee the performance capabilities of the unit, or its operation or reliability if it is used for specific purposes. Under no circumstances can *SDMO Industries* be held responsible for any consequential loss, whether or not arising out of material damage, which includes but is not limited to the following: Any operating losses, costs or expenses resulting from unavailability of the unit, etc. The warranty is limited to the cost related to the repair or replacement of the unit or one of its components, excluding consumables. The warranty therefore covers the costs of parts and labour, excluding travel costs. The cost of transporting the unit or one of its components to the workshops of *SDMO INDUSTRIES* or one of its approved agents shall be borne by the Customer; the "return" transport costs shall be borne by *SDMO Industries*. However, in the event that the warranty does not apply, all transport costs shall be borne by the Customer.

CASES OF EXCLUSION FROM THE WARRANTY:

Warranty exclusion applies in the following cases: damage resulting from transporting the unit; incorrect installation or installation not complying with *SDMO Industries* recommendations and/or technical and safety standards; use of non-recommended products, components, replacement parts, fuel or lubricants; incorrect use or misuse of the unit; modification or conversion of the unit or any of its components not authorized by *SDMO Industries*; normal wear and tear of the unit or of one of its components; damage due to negligence, failure to monitor, service or clean the unit; force majeure, acts of God or other external causes (natural disaster, fire, impact, flooding, lightning, etc.); operation of the unit with insufficient load; inadequate storage conditions of the unit. The following components are also excluded from the warranty: the starter systems (batteries, starter motors, starter), the filters, the belts, the fuses, the switches, the lamps, the commutators, and all consumables and wearing parts.

TERMS AND CONDITIONS FOR APPLICATION:

The warranty must be applied by the distributor from which you purchased your unit. You are requested by *SDMO Industries* to locate your purchase invoice and contact the distributor or, where applicable, the Customer Service Department of *SDMO Industries*. Staff from this department can answer your questions concerning the warranty's application conditions; contact details are as follows: *SDMO Industries*, 270 rue de Kerervern – 29490 GUIPAVAS / CS 40047- 29801 BREST CEDEX 9 – Tel: France 0.806.800.107 (call charge) – Fax: +33298416307.

LEGAL GUARANTEES

Information for the consumer, who is defined as any individual acting for purposes outside of his or her trade, business, craft or profession.

SDMO Industries is liable for any conformity issues with your unit under the conditions set out in article L. 211-4 and following of the Consumer Code and for hidden defects in the sold item under the conditions set out in articles 1641 and following of the civil code. Under the conformity guarantee:

- you have a period of 2 years from the date your unit was delivered to make a claim under the statutory conformity guarantee.
- you may choose between repair or replacement of your unit, subject to the conditions set out in article L. 211-9 of the Consumer Code.
- you are required to send proof of the existence of the conformity issue with your unit within 6 months of the item's delivery. This period is extended to 24 months from 18 March 2016; this does not apply to used items.

The statutory guarantee applies independently of the commercial warranty provided by *SDMO Industries*.

You may also decide to implement the guarantee applicable to hidden defects with your unit under the conditions set out in article 1641 of the Civil Code. If there is a hidden defect with your unit, and you are required to provide proof, you may choose between cancellation of the sale or a reduction in the sale price in accordance with article 1644 of the Civil Code.

Articles of the Consumer Code

Article L211-4

The vendor is required to deliver goods that comply with the contract and is answerable for any non-compliances existing on delivery. It is also answerable for any non-compliances resulting from packing, assembly instructions or installation when in the charge of the latter under the terms of the contract or when carried out under its responsibility.

Article L211-5

To comply with the contract, the goods must:

1. Be suitable for the use customarily expected of similar goods and, if applicable, must:
 - match the description given by the Vendor and possess the qualities that the Vendor has presented to the Buyer in the form or a sample or model;
 - have the qualities a Buyer can legitimately expect, considering the public statements made by the Vendor, the producer or its representative, particularly in its advertising or labeling;
2. Or alternatively, present the characteristics mutually defined by the parties or be suitable for any special purpose desired by the Buyer which has been made known to the Vendor and which the Vendor has accepted.

Article L211-12

Action arising from a non-compliance is limited to a period of two years from the date of delivery of the goods.

Article L.211-16

When, during the term of the commercial warranty granted to the Buyer when the goods were purchased or repaired, the Buyer requests a repair from the Vendor which is covered by the warranty, any period of immobilisation of seven days or more shall be added to the remaining term of the warranty. This period shall apply from the date the Buyer requests that work is performed or when the goods in question were made available for repair, if this second date precedes the request for the work to be performed.

Articles of the Civil Code

Article 1641

The vendor is bound by the warranty for any hidden defects in the item sold which make it unsuitable for its intended purpose or which limit the said purpose to such an extent that the purchaser would not have acquired it, or would only have paid a lower price had they been aware of it.

Article 1648 sub-paragraph 1

The purchaser must instigate action resulting from unacceptable defects within two years of discovering the defect.