

Congratulations on the purchase of your log periodic aerial. The aerial is ideal for the reception of all available signals in strong and medium areas.

- F type connection
- Gain 6dBi
- Highly directional for high signal to noise ratio,
- Very low wind resistance
- Supplied fully assembled with mast clamp, F connector and rubber weather boot

Installation Instructions

For optimum results install the aerial using double screened CAI approved digital coax cable and screened coax outlets. You will need to fit the coax cable with the F type connector supplied to connect to the download (not supplied) to the F socket on the aerial.

1. Prepare the Coax Cable: Firstly fit the rubber weather boot provided, to the aerial end of the cable. Strip the end of the cable as shown in Fig. 1. Once you have stripped the cable, twist the braid and pull it back on itself, make sure that no braid is touching the copper core, this will cause a short on the cable and you will not get any signal.
2. Fitting the F connector: Now, simply twist on the 'F' connector supplied and trim the central conductor.

Fig. 1

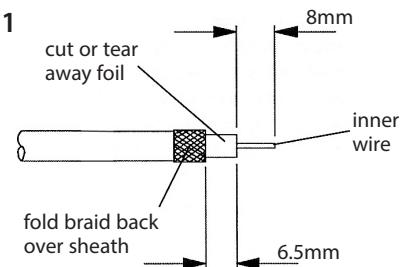
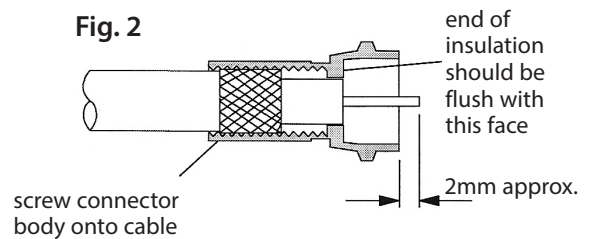

Fig. 2



For best results the aerial should be mounted on an outdoor aerial mast and pointed in the direction of the nearest transmitter* making sure it is in a position where the transmitter signal will not be obstructed by nearby trees and buildings. If you are in any doubt about the direction in which the aerial should be pointing or the orientation of the aerial (horizontal for main transmitter, vertical for relay transmitter) check your neighbours' aerials. The plate for the bracket has extra holes drilled at right angles to allow vertical mounting of the aerial.

The aerial comes fully assembled.

If mounting on an existing mast check that the mast is in good condition and firmly fixed.

3. Use the mast clamp supplied and tighten the wing nuts tightly until the aerial is held firmly in a horizontal position as shown in Fig. 3.

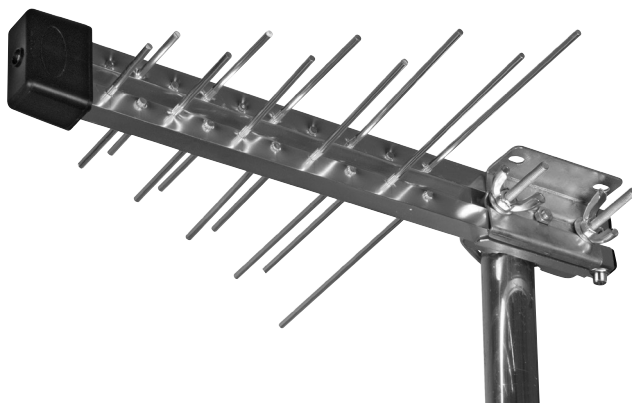
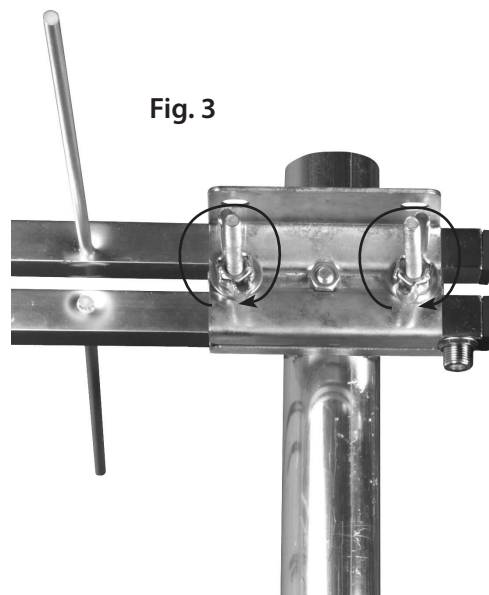
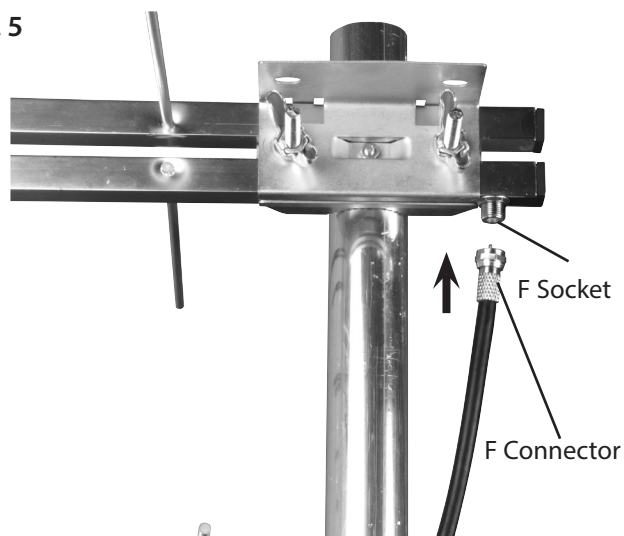

Fig. 3



4. Connect the aerial downlead to the 'F' socket on the back of the aerial (be careful not to over tighten the F connector) see Fig. 5.

Fig. 5



5. Slide the weather boot over the 'F' connector and socket to make a good seal - see Fig. 6. Make sure that the coax cable is taped to the mast. Use insulating tape, to secure the the coax downlead to the mast.

Fig. 6

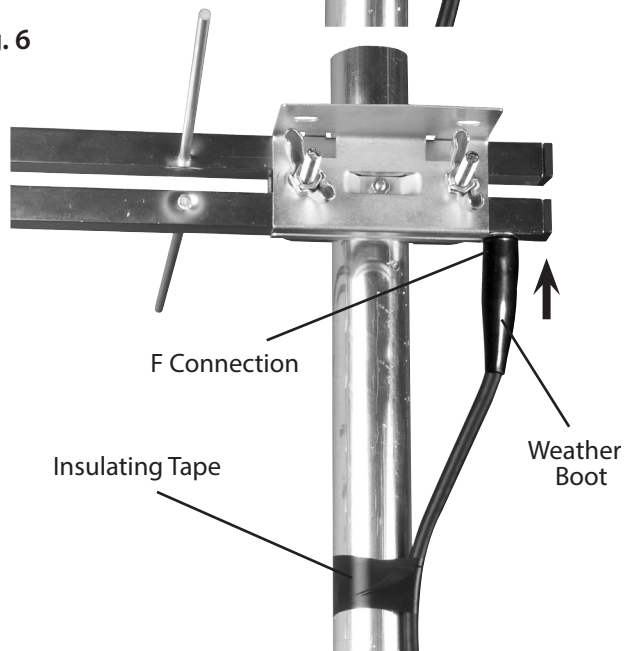

6. Finally connect the aerial to your TV or other reception device and check the picture. Fine adjust the direction of the aerial to obtain the optimum signal reception.

Troubleshooting

No picture:

Check all connections from aerial to TV.

Poor picture:

Check all connections from aerial to TV.
Check aerial is properly aligned to the correct transmitter.
If the aerial has been loft mounted try mounting outside.

Make sure new digital coax cable has been used throughout the installation.

Caution

When mounting the assembled aerial, always observe safety precautions and use the correct equipment.

Unless you are competent in the use of ladders and other access equipment, do not work outdoors at roof height.

If in any doubt, refer to a qualified aerial installer.

Check the transmitter signal is not obstructed by nearby trees or buildings.

If in a very weak signal area or for long cable runs, installing a masthead amplifier will improve the signal.

If in a strong signal area the signal strength may need to be reduced by fitting an attenuator.

For further information, please contact:

Customer careline: 08457 573479

(Local Rate - UK Only)

Technical Support: www.philex.com/support/

Other Useful Websites for Digital Advice:

*To find out what DTT channels should be available locally and to find out where your nearest transmitter is (distance and compass bearing) visit: **Digital UK Website:** <http://www.digitaluk.co.uk/postcodechecker/>