



# 50cm Hedge Trimmer

with 20V 2Ah Lithium-Ion Battery & Charger

WEV20HT  
1938201002

## en - Original Instructions

**Save these instructions**

**Sales & Support: 01793 333212**

Before use please read & understand this manual; paying particular attention to the safety instructions before use.

Incorrect use of the product could put the operator or machine in danger.

Whilst every effort has been made to ensure the accuracy of information contained in this manual, our policy of continuous improvement determines the right to make modifications without prior warning.

Images are used for illustration purposes only.



## INSTRUCTION MANUAL

14 October 20

---

### *Copyright Notice*

Copyright © Handy Distribution

Permission is granted to reproduce this publication for personal & educational use only.

Commercial copying, redistribution, hiring or lending is prohibited.

No part of this publication may be stored in a retrieval system or transmitted in any other form or means without written permission from Handy Distribution.

In all cases this copyright notice must remain intact.

## **CONTENTS**

### **INTENDED USE**

### **GENERAL SAFETY INSTRUCTIONS**

### **SPECIFICATION**

### **KNOW YOUR MACHINE**

### **BATTERY**

### **CHARGING**

### **OPERATION**

### **CLEANING & MAINTENANCE**

### **STORAGE & TRANSPORTATION**

### **TROUBLE SHOOTING**

### **PARTS DIAGRAM & LIST**

### **EC DECLARATION OF CONFORMITY**

### **INTENDED USE**

The basic version of the equipment is a handheld lithium battery powered hedge-trimmer, intended for private use, i.e. for use in home and gardening environments. It is designed to cut foliage with a maximum diameter of 16mm.

The hedge-trimmer is for private use only, whose annual operating time generally does not exceed 50 hours. Public facilities, sporting facilities and agricultural / forestry applications are excluded.

Please read this entire manual prior to operating the equipment. It instructs you how to safely and easily set up, operate and maintain your machine. Please be sure that you and any other persons who will operate the machine, always carefully follow the recommended safety practices. Failure to do so could result in personal injury or property damage.

#### **TO THE OWNER**

All information in this manual is relative to the most recent product information available at the time of printing. Review this manual frequently to familiarise yourself with the machine, its features and operation. Please be aware that this Instruction Manual may cover a range of product specifications for various models. Characteristics and features discussed and/or illustrated in this manual may not be applicable or exact to all models.

We reserve the right to change product specifications, designs, and equipment without notice and without incurring obligation. If you have any problems or questions concerning the machine, phone your local authorised service dealer or ourselves. Throughout this manual, all references to *right* and *left* side of the machine are observed from the operating position.



## INSTRUCTION MANUAL

















### **WARNING**

For safety reasons, the hedge-trimmer may not be used as a drive unit for other equipment or toolkits of any kind, unless specifically advised to do so by the manufacturer. The equipment is to be used only for its prescribed purpose. Any other use is deemed to be a case of misuse. The user/operator and not the manufacturer will be liable for any damage or injuries of any kind caused because of this.

Please note that our equipment has not been designed for use in commercial, trade or industrial applications. Our warranty will be 90 days from the original date of sale for commercial, trade or industrial businesses or for equivalent purposes.

## GENERAL SAFETY INSTRUCTIONS

It is important that you read and understand the owner's manual and labels affixed to the machine. Learn its application and limitations as well as the specific potential hazards. Retain these instructions for future reference. The operator is responsible for following the warnings & instructions in this manual and on the product.

	Read & understand operator's manual before using the machine. Failure to follow instructions could result in death or serious injury.		Always hold the hedge trimmer with both hands when operating.
	Wear gloves to protect your hands Wear safety shoes.		Check your machine before turning it on. Keep guards in place & in working order. Frequently check to see that foreign objects are removed from the working area before turning it on. Replace damaged, missing or failed parts before using it.
	Whenever the machine is in use, safety glasses must be worn to safeguard against flying objects. Hearing protection must also be used to protect the users hearing. Face masks are also recommended to avoid inhalation of debris.		Do not expose to rain or damp conditions
	Keep all bystanders & animals at least 15 metres away from the machine during operation. If approached, stop the machine immediately.		<b>STAY ALERT</b> Safety alert symbol. Used to alert you to potential personal injury hazards. Obey all safety messages that follow this symbol to avoid possible injury.
 <b>DANGER</b>	Indicates an imminently hazardous situation which, if not avoided, will result in serious injury.	 <b>WARNING</b>	Indicates a potentially hazardous situation which, if not avoided, could result in serious injury.
 <b>CAUTION</b>	Indicates a potentially hazardous situation which, if not avoided, may result in minor or moderate injury.	<b>CAUTION</b>	Used without the safety alert symbol, indicates a potentially hazardous situation which, if not avoided, may result in property damage.
	According to the European directive 2012/19/EU for Waste Electrical & Electronic Equipment and its implementation into national law, electrical and electronic equipment that are no longer usable must be collected separately & disposed of in an environmentally correct manner.		Sound Power Level (Image used for illustration purposes only, check machine and Declaration of Conformity for actual reading)
	CE marking is a certification mark that indicates conformity with health, safety, and environmental protection standards for products sold within the European Economic Area.		Separate collection of used products and packaging allow materials to be recycled & used again. Reuse of recycled materials helps prevent environmental pollution and reduces the demand for raw material.



# INSTRUCTION MANUAL

## GENERAL SAFETY RULES



### WARNING

Before you put the machine into operation, you must read this instruction manual.

When using this machine, observe the following safety instructions to remove the risk of personal injury or material damage. Please also observe the special safety instructions in the respective chapters. Where applicable, follow the legal directives or regulations for the prevention of accidents in relation to the use of this machine.

When using electric/battery tools, basic safety precautions, including the following, should always be followed to reduce the risk of serious personal injury and/or damage to the unit.

## GENERAL OPERATION

1. Read this instruction manual carefully in its entirety before attempting to assemble this machine. Read, understand, and follow all instructions on the machine and in the manual(s) before operation. Keep this manual in a safe place for future and regular reference and for ordering replacement parts.
2. Be completely familiar with the controls and the proper use of this machine before operating it.
3. This machine is a precision piece of power equipment, not a plaything. Therefore, always exercise extreme caution. This machine has been designed to perform one job: to cut out moss and weeds from the root. Do not use it for any other purpose.
4. Never allow children under 16 years of age to operate this machine. Children 16 and over should read and understand the instructions and safe operation practices in this manual and on the machine and should be trained and always supervised by an adult.
5. Only responsible individuals who are familiar with these rules of safe operation should be allowed to use this machine.
6. Thoroughly inspect the area where the equipment is to be used. Remove all stones, sticks, wire, bones, toys, and other foreign objects, which could be tripped over or picked up and thrown by the machine. Thrown objects can cause serious personal injury.
7. Plan your working pattern to avoid discharge of material toward roads, pathways, bystanders, and the like. Also, avoid discharging material against a wall or obstruction, which may cause discharged material to ricochet back toward the operator.
8. To help avoid blade contact or a thrown object injury, stay in operator zone behind handles and keep children, bystanders, helpers, and pets at least 20 metres from machine while it is in operation. Stop machine if anyone enters area.
9. Always wear safety glasses or safety goggles during operation and while performing an adjustment or repair to protect your eyes. Thrown objects which ricochet can cause serious injury to the eyes.
10. Wear sturdy, rough-soled work shoes and close-fitting trousers and shirts. Shirts and trousers that cover the arms and legs and steel-toed shoes are recommended. Never operate this machine in bare feet, sandals, slippery or light-weight (e.g. canvas) shoes.
11. Do not put hands or feet near or in moving parts, especially the cutting blades.
12. Never operate the machine without proper shields, guards, control lever or other safety protective devices in place and working.
13. Never operate the machine with damaged safety devices. Failure to do so, can result in personal injury.
14. Do not hold on to the machine if you are falling; release the handle immediately.
15. Do not operate the machine while under the influence of alcohol or drugs.
16. The trigger/lever mechanisms are a safety device. Never attempt to bypass its operation. Doing so makes the safety device inoperative and may result in personal injury through contact with the moving blades. The trigger/lever must operate easily in both directions and automatically return to

- the disengaged position when released.
17. Never operate in wet grass. Always be sure of your footing. A slip and fall can cause serious personal injury. If you feel you are losing your footing, release the trigger/lever immediately and the blades stop moving after release.
  18. Operate only in daylight or good artificial light. Walk, never run.
  19. Stop the blades when moving to another work area.
  20. If the machine starts to vibrate abnormally, stop the motor, and check immediately for the cause. Vibration is generally a warning of trouble.
  21. Shut the motor off and wait until the blades come to a complete stop. Then remove the battery before cleaning the blades. Never place any part of the body in the blade area until you are sure they have stopped moving and battery has been removed from the machine and contact cannot be made between the two.
  22. Never operate without proper shields, discharge cover, trigger/lever or other safety protective devices in place and working. Never operate with damaged safety devices. Failure to do so can result in personal injury.
  23. Only use parts and accessories made for this machine by the manufacturer. Failure to do so can result in personal injury.
  24. If situations occur which are not covered in this manual, use care and good judgement. Contact your nearest Approved Service Dealer for assistance

#### **SLOPE OPERATION**

Slopes are a major factor related to slip and fall accidents, which can result in severe injury. Operation on slopes requires extra caution. If you feel uneasy on a slope, or it is greater than 15 degrees, do not scarify on it.

##### **Do:**

1. Exercise extreme caution when changing direction on slopes.
2. Watch for holes, ruts, rocks, hidden objects, or bumps which can cause you to slip or trip. Tall grass can hide obstacles.
3. Always be sure of your footing. A slip and fall can cause serious personal injury. If you feel you are losing your balance, release the trigger/lever immediately and the blades will stop immediately.

##### **Do Not:**

1. Do not use near drop-offs, ditches, or embankments, you could lose your footing or balance.
2. Do not scarify on slopes greater than 15 degrees.
3. Do not scarify on wet grass. Unstable footing could cause slipping.

#### **CHILDREN**

Tragic accidents can occur if the operator is not alert to the presence of children. Children are often attracted to the machine and the activity. They do not understand the dangers. Never assume that children will remain where you last saw them.

1. Keep children out of the cutting area and under care of a responsible adult other than the operator.
2. Be alert and turn the hedge-trimmer off, if a child enters the area.
3. Before and while moving backwards, look behind and down for small children.
4. Use extreme care when approaching blind corners, doorways, shrubs, trees, or other objects that may obscure your vision of a child who may run into the operator.
5. Never allow children under 16 years of age to operate this machine. Children 16 and over should read and understand the instructions and safe operation practices in this manual and on the machine and be trained and supervised by an adult.



# INSTRUCTION MANUAL

## SERVICE

### General Service:

1. Before cleaning, repairing, or inspecting, make certain the blades and all moving parts have stopped. Disconnect the battery from the machine to prevent unintended starting.
2. Check the blades at frequent intervals for proper tightness. Also, visually inspect blades for damage. Replace with the original equipment manufacture's (O.E.M.) parts only, listed in this manual. "Use of parts which do not meet the original equipment specifications may lead to improper performance and compromise safety!"
3. Keep all nuts, bolts, and screws tight to be sure the equipment is in safe working condition.
4. Never tamper with safety devices. Check the correct operation regularly.
5. After striking a foreign object, stop the motor, disconnect the battery from the machine. Thoroughly inspect for any damage. Repair the damage before starting and operating the machine.
6. Hedge-trimmer components, guards and shields are subject to wear and damage which could expose moving parts or allow objects to be thrown. For safety protection, frequently check components and replace immediately with original equipment manufacturers (O.E.M.) parts only, listed in this manual. "Use of parts which do not meet the original equipment specifications may lead to improper performance and compromise safety!"
7. Do not change the motor's settings. The motor has been set for the maximum safe operating speed.
8. Maintain or replace safety and instruction labels, as necessary.
9. Observe proper disposal laws and regulations. Improper disposal of fluids and materials can harm the environment.

### DO NOT MODIFY THE MOTOR

To avoid serious injury or death, do not modify the motor in any way. Tampering with the motor settings can cause it to operate at unsafe speeds and lead to premature failure. Never tamper with factory settings of the motor. Please refer to this manual, before undertaking any inspection, repair, or maintenance.

### PERSONAL SAFETY

1. This machine is not intended for use by persons (including children) with reduced physical, sensory or mental capabilities, or lack of experience and knowledge, unless they have been given supervision or instruction concerning use of the machine by a person responsible for their safety.
2. Children should be supervised to ensure that they do not use or play with the machine.
3. Stay alert, watch what you are doing and use common sense when operating this machine.
4. Do not use this machine while you are tired, ill or under the influence of drugs, alcohol, or medication. A moment of inattention while operating this machine can cause you to lose control & may result in series personal injury.
5. Use safety equipment. Always wear eye protection. Safety equipment such as a dust mask, non-skid safety shoes, hard hat, or hearing protection used for appropriate condition will reduce personal injuries.
6. Dress properly. Do not wear loose clothing or jewellery. Keep your hair, clothing & gloves away from moving parts. Loose clothes, jewellery or long hair can be caught in moving parts.
7. Prolonged use of the machine may lead to disorders of blood circulation in hands caused by vibration. These effects can be worsened by low ambient temperatures and/or by gripping the handgrips excessively tightly. Period of use you can extend with appropriate gloves or regular breaks. Take frequent work breaks. Limit the amount of exposure per day.



### **BATTERY TOOL USE AND CARE**

1. Recharge only with the charger specified by the manufacturer. A charger that is unsuitable for one type of battery may create a risk of fire when used with another battery.
2. Use power tools only with specifically designated battery. Use of any other battery may create a risk of injury and fire
3. When the battery is not in use, keep it away from other metal objects, like paper clips, coins, keys, nails, screws or other small metal objects, which can make a connection from one terminal to another. Shorting the battery terminals together may cause burns or a fire.
4. Under abusive conditions, liquid may be ejected from the battery; avoid contact.
5. If contact accidentally occurs, flush with water. If liquid contacts eyes, additionally seek medical help. Liquid ejected from the battery may cause irritation or burns.

### **HEDGE TRIMMER SAFETY WARNINGS**

1. Keep all parts of the body away from the cutter blade. Do not remove cut material or hold material to be cut when blades are moving. Make sure the switch is off when clearing jammed materials. A moment of inattention while operating the hedge trimmer may result in serious personal injury.
2. Carry the hedge trimmer by the handle with cutter blade stopped. When transporting or storing the hedge trimmer always fit the cutting device cover. Proper handling of the hedge trimmer will reduce possible personal injury from the cutter blades.
3. Hold the power tool by insulated gripping surface only, because the cutter blade may contact hidden wiring. Cutter blades contacting a "live" wire may make exposed metal parts of the power tool "live" and could give the operator an electric shock.

### **INTENDED USE**

The product is only intended for use outdoors. For safety reasons the product **MUST** be adequately controlled by using the two-handed operation. The product is designed for home or domestic use. It is intended to cut and trim hedges, shrubs and similar vegetation. It should be used in dry, well illuminated conditions. It is **NOT** intended to cut grass, trees or branches. It should not be used for any other purpose than hedge trimming.

### **RESIDUAL RISK**

Even when the product is used as described, it is still impossible to eliminate certain residual risk factors. The following hazards may arise in use and the operator should pay special attention to avoid the following:

1. The blades cannot be guarded whilst cutting. Contact with the blades can cause serious injury. Keep the blade away from yourself and others. Cover it with the blade protector whenever not in use.
2. Injury caused by vibration. Always use the right tool for the job, use designated handles and restrict working time and exposure.
3. Exposure to noise can cause hearing injury. Wear ear protection and limit exposure

### **RISK REDUCTION**

It has been reported that vibrations from hand-held tools may contribute to a condition called Raynaud's Syndrome in certain individuals. Symptoms may include tingling, numbness and blanching of the fingers, usually apparent upon exposure to cold. Hereditary factors, exposure to cold and dampness, diet, smoking and work practices are all thought to contribute to the development of these symptoms. There are measures that can be taken by the operator to possibly reduce the effects of vibration:

1. Keep your body warm in cold weather. When operating the unit wear gloves to keep the hands and wrists warm. It is reported that cold weather is a major factor contributing to Raynaud's Syndrome.
2. After each period of operation, exercise to increase blood circulation.
3. Take frequent work breaks. Limit the amount of exposure per day.

If you experience any of the symptoms of this condition, immediately stop use and see your doctor about these symptoms.



## INSTRUCTION MANUAL



**WARNING:**

Injuries may be caused, or aggravated, by prolonged use of a tool. When using any tool for prolonged periods, ensure you take regular breaks.



**DANGER OF FIRE!**

Never charge batteries in the vicinity of acids or easily flammable materials.

Charge battery only at a temperature between 10 - 45 °C. After a heavy load, first allow the battery to cool.



**DANGER OF EXPLOSION!**

Protect the device from direct exposure to heat and fire.

Do not place on heating units or expose to strong sunlight for an extended period.

Operate the device only at temperatures between -10 °C to + 45 °C..



**RISK OF SHORT CIRCUIT!**

For disposal, transport or storage, pack the battery in a plastic bag or a cardboard box, or isolate the contacts with adhesive tape.

Do not open the battery pack.

### SAFE DISPOSAL OF BATTERIES



Our batteries are designed according to the latest state of technology and optimised for the use in electric tools. Lithium ion cells contain hazardous substances and may therefore not be disposed off with normal household waste.

Our batteries are lithium ion cells and are therefore subject to special disposal regulations. Bring defective batteries to your specialist dealer. Before disposing of the tool, remove the battery.

We wish to encourage users to act in an environmentally friendly manner.

## SPECIFICATION

<b>Model</b>	<b>WEV20HT</b>
<b>Product Number</b>	<b>1938201002</b>
Voltage	18Vd.c (20Vd.c Max)
No Load Speed	1200 rpm
Blade Length	500 mm
Cutting Capacity	16 mm
Maximum Run Time (Unloaded)	45 mins
Charge Time (Up to)	4 hours
Guarantee Sound Power Level	L <sub>WA</sub> 99 dB(A) - K <sub>pA</sub> 3 dB(A)
Vibration	Front Handle 1.55 m/s <sup>2</sup> , Rear Handle 1.58 m/s <sup>2</sup> Uncertainty K: 1.5 m/s <sup>2</sup>
Weight without Battery	N.W 2.8kg

Consistent with our policy of continuous improvement, WEBB reserves the right to change the design and configuration of any of its products without notice or obligation. Therefore, please treat the text and images in this manual for illustrative purposes only. They may in no case serve as a basis for any legal claim.

**If you require any assistance with regards to the contents or operation of your machine, please call our Customer Service Team on 01793 333212 or email [customerservice@webbgardenpower.co.uk](mailto:customerservice@webbgardenpower.co.uk)**  
**Opening hours weekdays: February to October 8:30am - 5:30pm / November to January 8:30am - 5:00pm (Closed Bank Holidays)**



## INSTRUCTION MANUAL

### KNOW YOUR MACHINE

1. Rear Handle	2. Trigger
3. Front Handle	4. Safety Lever
5. Hand Guard	6. Blade Assembly
7. Blade Guard	8. Battery 2Ah
9. Charger	

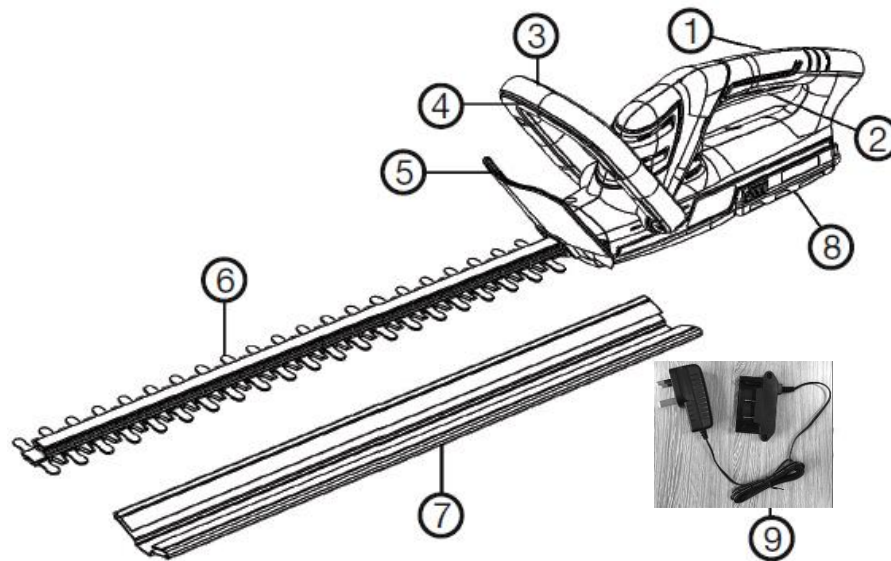

### BATTERY

#### CARE

- There will be some charge present in the Battery on delivery, but to ensure maximum running time, charge your Battery for 4-hours before first use.
- If over a period the Battery quickly runs down after a full 4-hour charging period, a replacement Battery is needed.
- To prevent permanent Battery damage, never store in a discharged condition.
- Contact your retailer or local approved service dealer for a replacement Battery and for safe disposal of your old Battery.
- The Battery is a "High Power", 20 Volt 2.0 Amp-Hour item. It is "Sealed for Life and no maintenance is required."

#### IMPORTANT

**Dispose of your old battery safely. Do not cut open, burn or incinerate.**

#### BATTERY INSTALLATION & REMOVAL

Hold the tool and the battery carriage firmly when installing or removing battery cartridge. Failure to hold the tool and the battery cartridge firmly may cause them to slip off your hands and result in damage to the tool and battery cartridge and a personal injury.

### TO REMOVE

Depress release button (A) on the back of battery cartridge (B) to release the battery. Pull the battery cartridge out of tool.

### TO INSTALL

Align the battery with the cavity in the handle. Insert the battery into the handle until the battery release button locks into place. You should hear a “click” once the battery is installed. Note: The battery can only be installed one way.

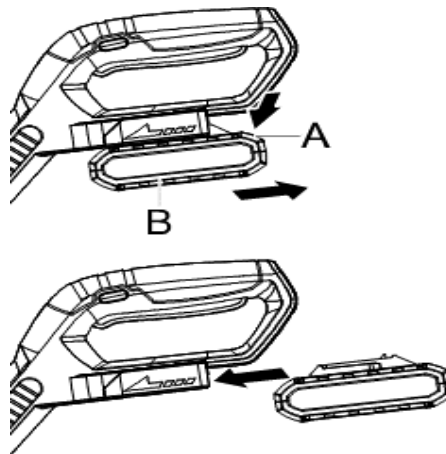

(Images may differ from actual machine)

### WINTER STORAGE

- Fully charge for 4-hours before winter storage.
- Re-charge the Battery every 3 to 4 months for a full 4-hour charging period to top up the battery during winter storage.
- Avoid extended storage without recharging.
- Store in a cool dry place.

## CHARGING



The battery must be charged for approximately 4 hours before using it for the first time. Use only the original charger supplied with this machine or approved replacement. Use charging unit only in dry rooms.

### CHARGING LIGHTS

Remove the battery from the charger once it is fully charged. Charging an empty battery will take up to 4 hours to fully recharge.

### BATTERY CHARGER



#### WARNING

Risk of electric shock and short circuiting. Use approved and intact wall sockets. Make sure that the cable is not damaged. Replace cable if it appears to be damaged in any way



## INSTRUCTION MANUAL

### CONNECTING CHARGER TO POWER SOURCE

Connect the battery charger to the voltage and frequency specified in this manual and on the rating plate. Put the electric plug in an earthed socket-outlet. The LED on the battery charger lights up green.

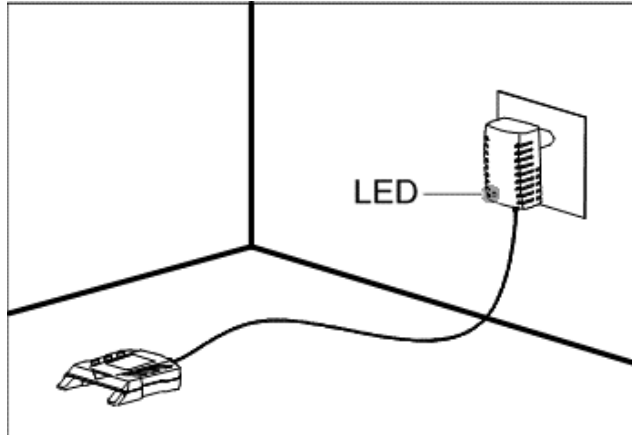

### CONNECTING CHARGER TO BATTERY

- The battery must be charged before using it the first time.
- Install charger on the top of battery and push until the charger connects firmly with the battery.
- The LED will turn RED on the charger, when the battery is connected to the battery charger.
- When the LED on the charger turns to GREEN, the battery is fully charged.
- Disconnect the power plug. Never pull the power cable of the charger to disconnect it from the wall socket.
- Remove battery from battery charger.

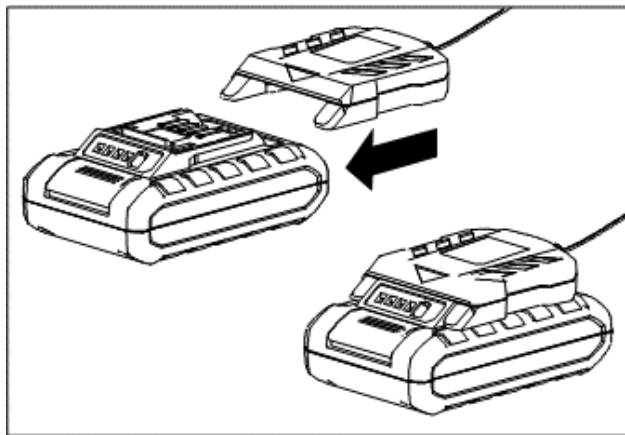

### NOTE:

Lithium-ion batteries can be charged at whatever charging level. The charging process can be cancelled or started whatever the battery's charge level is.

### WINTER STORAGE

- Fully charge for 4-hours before winter storage.
- Re-charge the Battery every 3 to 4 months for a full 4-hour charging period to top up the battery during winter storage.
- Avoid extended storage without re-charge.
- Store in a cool dry place.

### GENERAL INSTRUCTIONS:

In order to maintain the long service life of the battery, always follow the instructions below:

The line trimmer will automatically switch off when the battery voltage is low. The battery must then be recharged before the tool can be used again.

Always recharge the lithium-ion battery prior to any prolonged period of non-use, i.e. before storing away in autumn/winter.

The charging time is 4-hours maximum for a battery that is completely empty.

The lithium-ion rechargeable battery can be charged at any charge level and charging can be interrupted at any time without damaging the battery (no memory effect).

## OPERATION



### DANGER

Risk of injury! The device may only be put into operation if there are no defects. If a part is defective it must be replaced before the device is used again.



### WARNING

Risk of injury! Before starting work check the area and remove all objects which may be kicked up by the unit.

### SWITCHING ON AND OFF

Ensure the battery is housed in the trimmer, with an audible click.

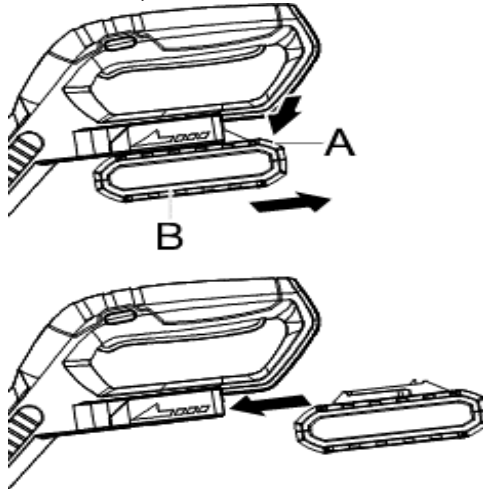

(Images may differ from actual machine)



## INSTRUCTION MANUAL

### Switching on:

Pull the On/Off trigger upwards with your right hand.

Push in the safety lever with your left hand.

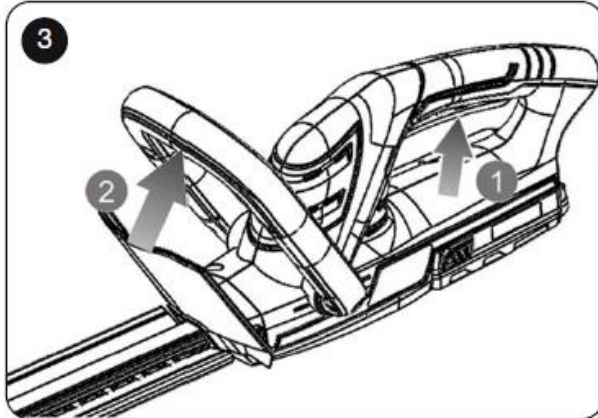

### Switching off:

Release the On/Off trigger or safety lever.



### WARNING

Never attempt to lock a switch in the ON position

### TRIMMING INSTRUCTIONS

**WORKING POSITION** (Figure 4) – Maintain proper footing and balance and do not overreach. Wear safety goggles, non-skid footwear when trimming. Hold the unit firmly in both hands and turn the unit ON.

Always hold the trimmer, as shown in the illustrations in this manual, with one hand on the trigger/rear handle and one hand on the safety lever. Never hold the unit by the hand.

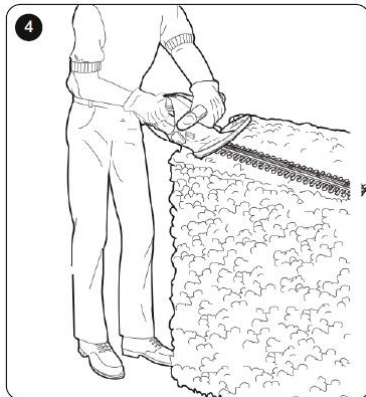



**TRIMMING NEW GROWTH** (Figure 5) - A wide, sweeping motion, feeding the blade teeth through the twigs is most effective. A slight downward tilt of the blade, in the direction of motion gives the improved cutting.



**CAUTION:**

Do not cut stems greater than 16 mm. Use the trimmer only for cutting normal shrubbery around houses and buildings.

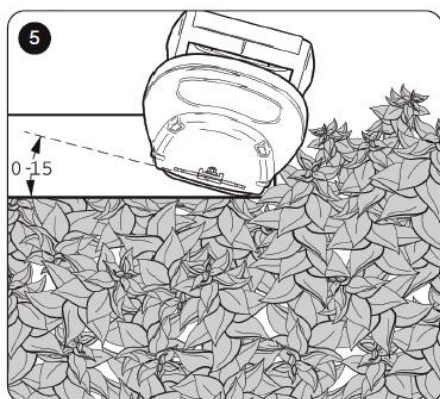

**LEVEL HEDGES** (Figure 6) – To obtain exceptionally level hedges, a piece of string can be stretched along the length of the hedge as a guide.

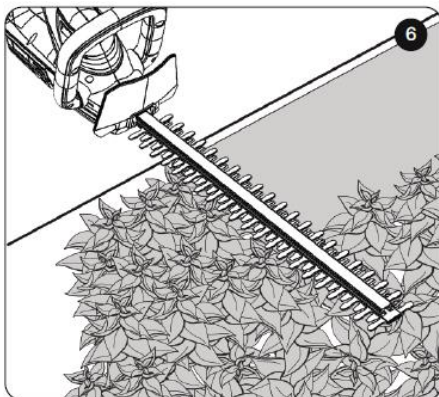

**SIDE TRIMMING HEDGES** (Figure 8) – Hold the trimmer as shown and begin at the bottom and sweep up.

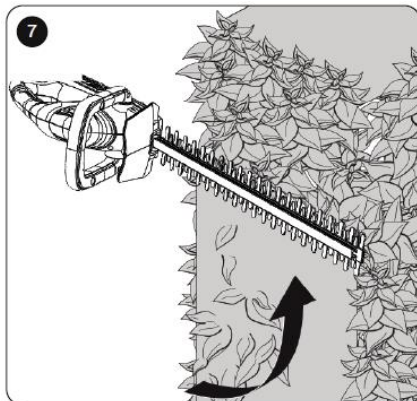



**WARNING**

To guard against injury, observe the following:

- Read this instruction manual before using. Save the instruction manual.
- Check the hedge for foreign objects, such as wire or fences before each use.
- Keep hands on handles. Don't overreach.
- Do not use under wet conditions.



**CAUTION**

Blade may coast after turning off.



**DANGER**

Keep hands away from blades.

## CLEANING & MAINTENANCE



**DANGER**

Prior to conducting maintenance or cleaning: Remove the battery from the machine.

The trimmer blade could still move after being switched off! Always remove battery before performing any work on the trimmer!

**Note:** Clean unit immediately after every use. Hedge debris when dry is very hard and are very difficult to remove.

**BEFORE EACH USE**

What?	How?
Check the battery, charger and machine for damage.	Conduct a visual inspection and have any faulty component replaced.

**IF NECESSARY**

What?	How?
Cleaning the device	Use a clean soft brush or damp cloth.
Lubricate blades	With a rust preventative solution or light machine oil

## MAINTENANCE

A plastic blade cover is supplied with your trimmer for storing. Remove the battery and slip the hedge trimmer blade into the sheath, as shown in (Figure 8).

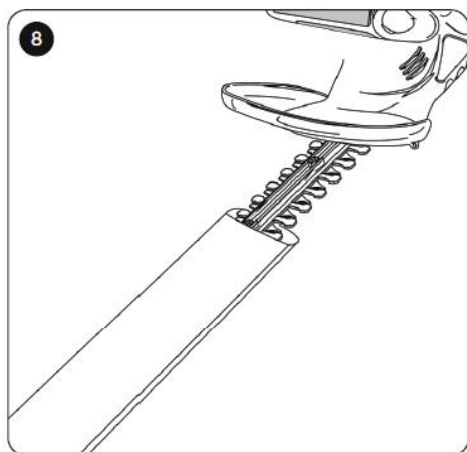

### WARNING

Remove battery before servicing, cleaning or removing material from the gardening appliance. The cutting blades are made from high quality, hardened steel and with normal usage, they will not require sharpening. However, if you accidentally hit a wire fence (figure 9), stones, glass or other hard objects, you may put a nick in the blade. There is no need to remove this nick if it does not interfere with the movement of the blade. If it does interfere, remove the battery and have an approved service dealer, use a fine-toothed file or sharpening stone to remove the nick. If you drop the trimmer, carefully inspect it for damage. If the blade is bent, housing cracked, or handles broken or if you see any other condition that may affect the trimmer's operation, contact your local approved service dealer for repairs before putting it back into use. Fertilisers and other garden chemicals contain agents which greatly accelerate the corrosion of metals. Do not store the unit on or adjacent to fertilisers or chemicals. With the battery removed, use only mild soap and a damp cloth to clean the unit. Never let any liquid get inside the unit; never immerse any part of the unit into a liquid. Prevent the blades from rusting by applying a film of light machine oil after cleaning.

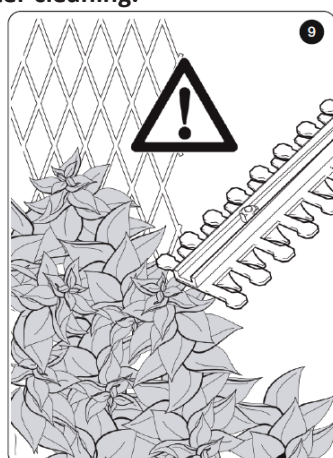



# INSTRUCTION MANUAL

## STORAGE

Store the tool in a dry and well-ventilated place.

## TRANSPORTATION

Always remove the battery from the machine and ensure the blade guard is securely placed over the blade assembly, when transporting the product.

## TROUBLE SHOOTING



**Switch off the trimmer and disconnect the battery before inspecting, cleaning or working on the thread.**

Error/Fault	Cause	Remedy
Slow running, noisy or hot blades.	Dry, corroded blades.	Lubricate blades with rust preventative solution or light machine oil.
	Blades or blade support bent.	Straighten blade or blade support. To be actioned by an approved service dealer.
	Bent or damaged teeth.	Straighten teeth. To be actioned by an approved service dealer.
	Loose blade bolts.	Tighten blade bolts.
Unit will not start.	Battery not installed properly.	Check battery installation.
	Battery not charged.	Check battery charging requirements.
	Safety Lever not fully operated.	Check that safety lever is fully pulled back prior to moving trigger.
Battery won't charge.	Battery not inserted into charger.	Insert battery into charger until green LED appears. Charge up to 4 hours if battery totally drained.
	Charger not plugged in.	Plug charger into a working outlet. Refer to "Important Charging Notes" for more details.
		Check current at outlet by plugging in a lamp or other appliance.
Surrounding air temperature too hot or too cold	Move charger and tool to an area which has a temperature of above 40° degree F (4.5°C) or below 105° degree F (+40.5°C).	

If you can't fix the fault yourself, contact your retailer. Please be aware that any improper repairs will also invalidate the warranty and additional costs may be incurred.





# INSTRUCTION MANUAL

## PARTS DIAGRAM

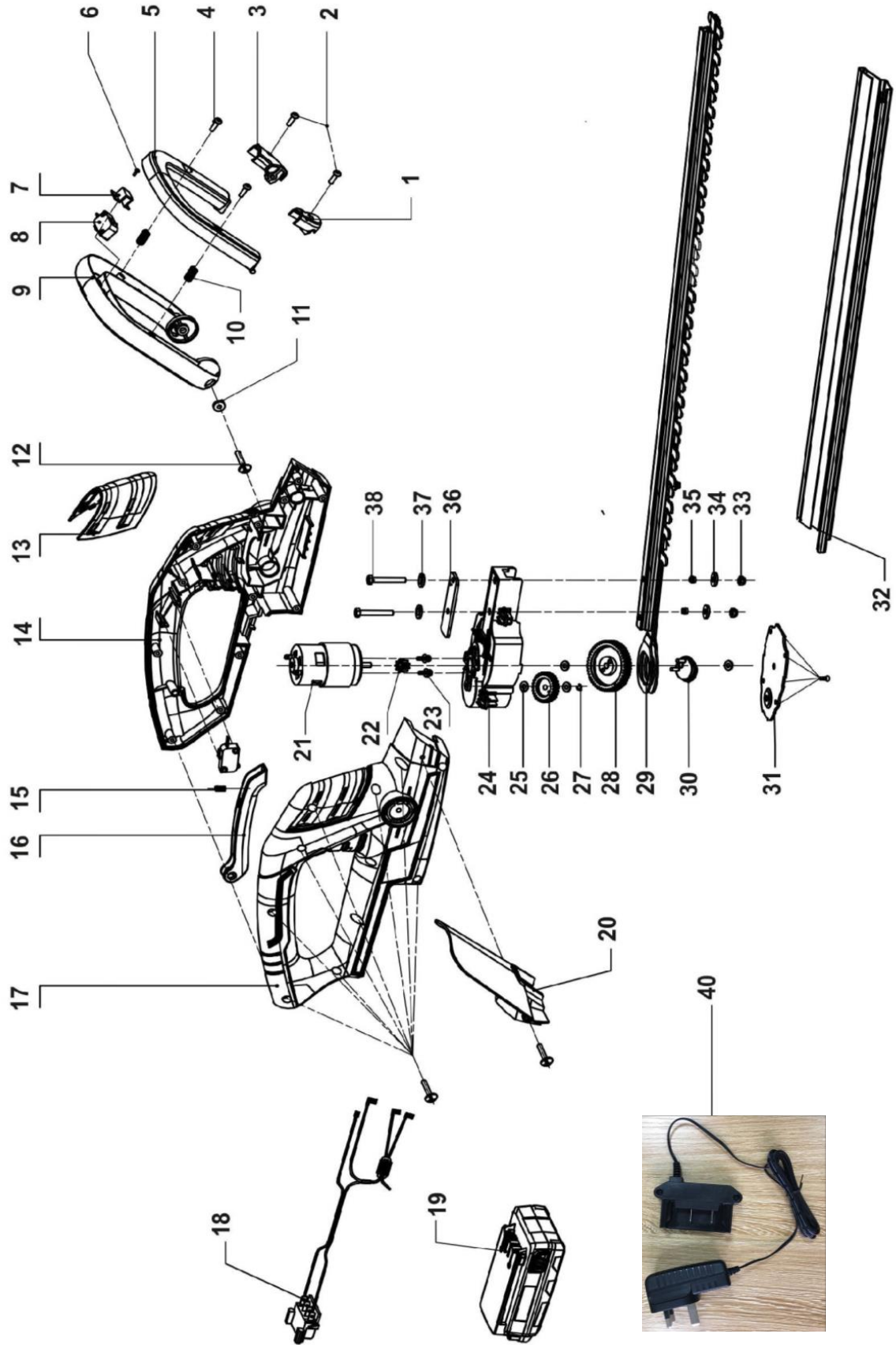

## PARTS LIST

Item No	Webb Part No.	Description	QTY	Item No	Webb Part No.	Description	QTY
1	WE144-301062870	Handle Right Cap	1	21	WE144-102010429	Motor Assembly	1
2	WE124-104030136	Self-Tapping Screw ST4.2x15	25	22	WE144-103070102	Motor Gear	1
3	WE144-301062871	Handle Left Cap	1	23	WE144-104030081A	Triple Screw Assembly	2
4	WE144-104030370	Cross Head Tapping Screw	2	24	WE144-301062873-1	Gearbox Assembly	1
5	WE144-301062872	Safety Lever	1	25	WE144-104010149	Shim	5
6	WE144-104030427	Self-Tapping Screw	2	26	WE144-103070101	Mid Gear	1
7	WE144-103020092	Switch Fixing Frame	1	27	WE124-104050028	Split Washer	1
8	WE144-102020110	Switch	2	28	WE144-103070100	Big Gear Wheel	1
9	WE144-301062873	Handle	1	29	WE144-4990076-1	Blade Assembly	1
10	WE144-103060234	Safety Lever Spring	2	30	WE144-103070099	Eccentric Gear	1
11	WE144-104010018	Flat Washer	2	31	WE144-103990626	Gear Box Cover	1
12	WE132-104040161	Cross Head Screw	2	32	WE144-301062752	Blade Cover	1
13	WE144-301062874	Motor Cover	1	33	WE125-104020017	Lock Nut	2
14	WE144-301062875	Left Housing Assembly	1	34	WE144-103040103	Flat Washer 2	2
15	WE137-103060073	Trigger Spring	1	35	WE144-103990627	Washer	2
16	WE143-301062665	Trigger	1	36	WE144-103990628	Support Bar	1
17	WE144-301062876	Right Housing Assembly	1	37	WE144-104010086	Spring Washer	2
18	WE144-4100138	Internal Conductor Assembly	1	38	WE144-104040178	Hex Bolt	2
19	WEV20B2	20V Battery	1	40	WEV20C	20V Charger	1
20	WE144-301062877	Hand Shield	1				



## EC DECLARATION OF CONFORMITY

**We Handy Distribution Ltd - SN3 5HY (Importer) declare that the product:**

**Designation:** Lithium-ion Battery Hedge Trimmer

**Model(s):** WEV20HT

**Product Number:** 1938201002

**Type/Serial No.** As per rating label on machine

**Battery:** 18Vd.c - 20V d.c Max

**No Load Speed:** 1200 rpm

**Max. Cutting Width:** 16 mm

**This machine conforms to EU Directives, to which this declaration relates & corresponds to the relevant basic safety and health requirements of Directive:**

Machinery Directive 2006/42/EC

EMC Directive 2014/30/EU

**For the relevant implementation of the safety and health requirements mentioned in the Directives, the following standards and/or technical specification(s) have been respected:**

EN 60745-1:2009+A11:2010, EN 60745-2-15:2009+A1:2010

EN 55014-1:2017, EN 55014-2:2015

**Guaranteed Sound Power Level:**  $L_{WA} = 90\text{dB(A)}$

**Vibration Level:** Front Handle  $1.55\text{ m/s}^2$ , Rear Handle  $1.58\text{ m/s}^2$  (Uncertainty K:  $1.5\text{ m/s}^2$ )

**Notified Body:**

Intertek Testing Services Shanghai

**Addresses:**

Building No. 86, 1198 Qinzhou Road (North), Shanghai 200233, China

**Authorised signatory and technical file holder**

**Date:** 13/10/2020

**Name:** Mr Simon Belcher

**Signature:**

**Position:** Chairman

**Company:** Handy Distribution Ltd

**Address:** Murdock Rd, Swindon, Wiltshire, SN3 5HY.







## INSTRUCTION MANUAL

This Service Book is provided with your Webb, to help you look after your purchase to our recommendations and enable you to take advantage of the conditional manufacturer domestic warranty\*.

Present this service book to your authorised Webb repair dealer, whenever a service or a warranty appraisal is required.

The booklet is applicable to the following products, in the UK only:

- Ride On Lawn Tractors
- Cylinder Lawnmowers
- Petrol Rotary Lawnmowers
- Petrol Hand Held Range

Please register your machine using the following pages or at [www.webbgardenpower.co.uk](http://www.webbgardenpower.co.uk). By registering your machine, you agree to maintain the machine in accordance with the service schedules specified in this manual and services duly recorded. (Not applicable for Webb electric handheld machines). You may be asked to produce this booklet as proof of servicing in the event of a claim. Proof of purchase should also be kept as a reference.

Ensure you have the following information available from your machine product label. The two examples below can be found on your machine:



1. Model Number

2. Serial & Product Number

Please complete using BLOCK CAPITALS.  
Sections marked\* must be completed to validate Warranty.

### 1. Users Statement of Warranty

Each new machine is warranted against defective material or assembly of material under normal usage. The warranty applies to the original purchaser, is not transferable and covers faulty parts and the labour involved in replacing and repairing those parts, which are of original manufacture.

### 2. Period of Warranty - valid from 1 January 2020

**Webb (excludes Dynamic, Legacy & Heritage)**, 2 year conditional warranty from the original date of sale to the first domestic user.

**Webb (Dynamic, Legacy & Heritage)** 1 year warranty from the original date of sale to the first domestic user.

90 days from the original date of sale to the professional/commercial or for hire user.

Engine warranty as per the engine manufacturer's warranty, which will be supplied with the machine.

90 days from the original date of sale for Replacement Spare Parts

All machines' must be serviced within the first 14 months from the original date of purchase, to qualify for a second year parts & labour warranty, details of the service must be recorded in the service record within this manual.

A reduced warranty period of 90 days applies to those items which are subject to normal wear and tear and in normal use, will need replacement or adjustment.

These items are chargeable after 90 days of ownership.

Filters  
Tyres / Wheels  
Drive chains and belts  
Brake & clutch friction components  
Control cable & starter cords  
Fluids & lubricants  
Spark plugs  
Blades (Lawnmowers & Brushcutters)  
Cutter bars (Hedgecutters)  
Drive & clutch cable surfaces  
Nylon Lines (Line Trimmers)  
Carburettor cleaning  
Bearings  
Bushes  
Electric cable  
Grass collectors

### 3. Not covered by this warranty

(a) The warranty policy does not cover any depreciation or damages caused by ordinary wear, rusting or corrosion, lack of correct maintenance or operation, misuse, abuse, lack of transportation or accident.

(b) The warranty policy does not cover any costs necessary for the standard periodic maintenance services instructed by the operators manual, or service parts replacement which would include oil, filters, tyres, belts, brake linings, fuses, blades, seals and other service parts unless it can be proven that the item has evidence of faulty manufacture.

(c) The warranty policy will not cover failure or damage caused as a result of parts or accessories being modified without the written approval of GJ Handy & Co Ltd.

(d) The warranty policy will not cover the unit if non-genuine parts have been fitted and as a result damage has occurred to the unit.

(e) The warranty policy is non-transferable and is only applicable to the original purchaser.

### 4. Disclaimer

(a) This warranty is only a remedy for defect of products. GJ Handy & Co Ltd will never warranty in terms of the merchantability or the fitness for a particular purpose.

(b) No person is authorised to make any warranties, representations or promises, expressed or implied, on behalf of GJ Handy & Co Ltd, or to modify the terms conditions or limitation of this warranty policy in any way.



## INSTRUCTION MANUAL

(c) Neither GJ Handy & Co Ltd nor any company affiliated with GJ Handy & Co Ltd shall be liable in any event or manner whatsoever for incidental or consequential damages or injuries, including, but not limited to, loss of crops, loss of profit, out of pocket expenses or profits, rental of substitute equipment or other commercial losses.

### *5. General*

(a) Most warrantable failures show up within the first few weeks of use. These failures are usually straightforward and warranty assessment is relatively easy.

(b) Failures relating to cutter decks and belts need careful investigation, as the cause may not always be straightforward. Look for damage to blades and pulleys especially when the cutter belt or blade boss have snapped or cracked as this could be due to impact damage.

(c) Customers should always refer to the operator/instruction manual when any disputed problem arises, you will find most areas covered within the manual.

## Protecting your machine

### *Maintenance*

Regular maintenance of your Webb machine is essential to ensure it operates, safely, efficiently and therefore reducing the environmental impact.

It is the owner's responsibility to ensure that their Webb machine is maintained at specific intervals. Any approved Webb service dealer can undertake a service, which are specialised in our products and will be aware of your particular machine and any technical updates which will save valuable time & money.

If you are using your machine in dry, dusty or high temperatures, you will need to service the machine more regularly.

### *Fuel (if applicable)*

Due to ongoing efforts by fuel companies to reduce emissions, unleaded petrol will oxidize & deteriorate in storage overtime, leaving residue from detergent components.

Fuel deterioration problems may occur when petrol is stored for over 30 days. If you are planning to store fuel for over 30 days, we recommend you add Handy Parts Sure-Start fuel stabilizer to fresh fuel after purchasing. Sure-Start cannot reconstitute stale fuel.

### *Storage*

When storing your machine for an extended period, we do recommend that you follow the instructions of engine instruction manual.

Always store the fuel in a clean, approved and sealed container. If the container is steel, ensure it is not corroded. If the container is not filled to its recommended capacity, air can accelerate fuel deterioration.

Always store fuel away from direct sunlight, in a dark, cool environment.

Your servicing Webb approved dealer will stamp & date the below relevant sections, when the correct service actions have been completed.  
PLEASE ENSURE THE SERVICE BOOK IS AVAILABLE FOR THE DEALER, DURING SERVICE WORK.

## 1st Service

This must be stamped by an approved service dealer to qualify for a free second year warranty.  
(Excluding the Webb Electric Handheld machines)

12 Months

Date

24 Months

Date

36 Months

Date



## INSTRUCTION MANUAL

48 Months

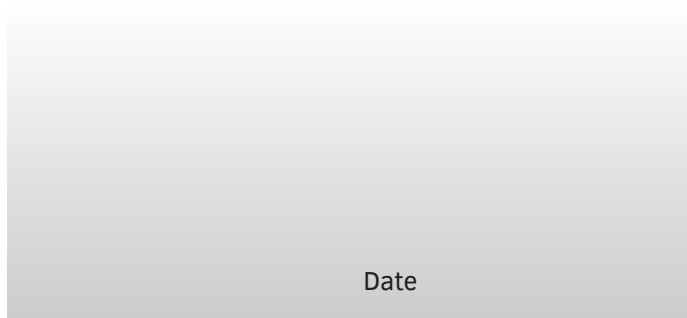

60 Months

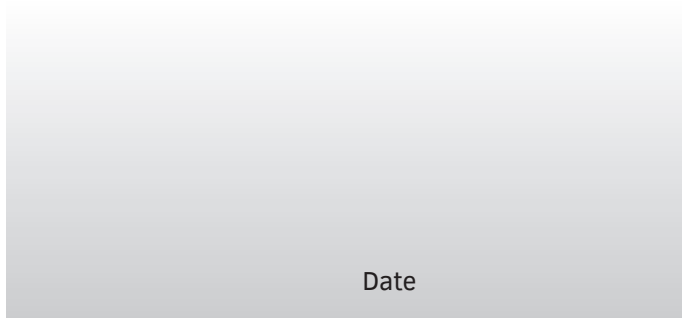

72 Months

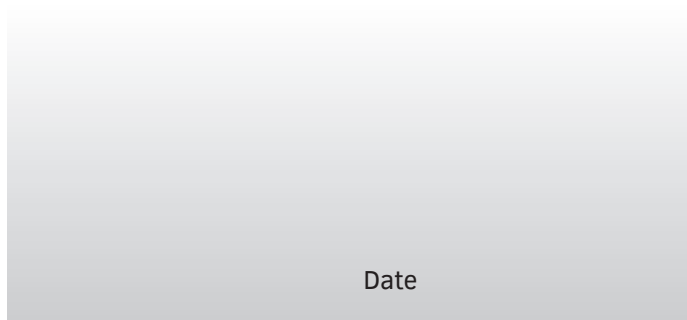

84 Months

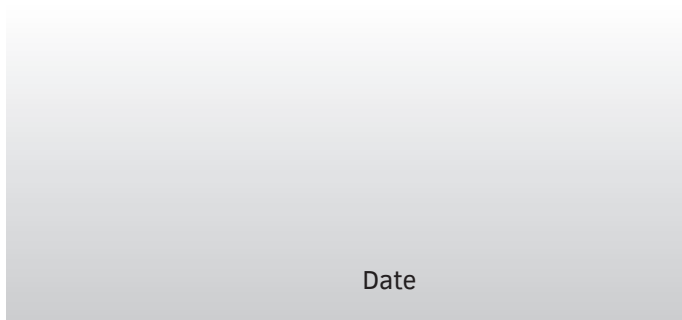

96 Months

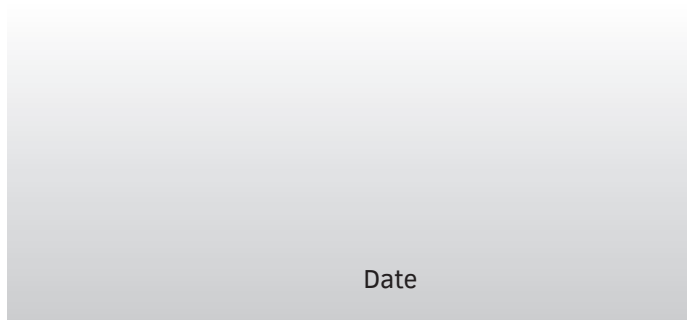

108 Months

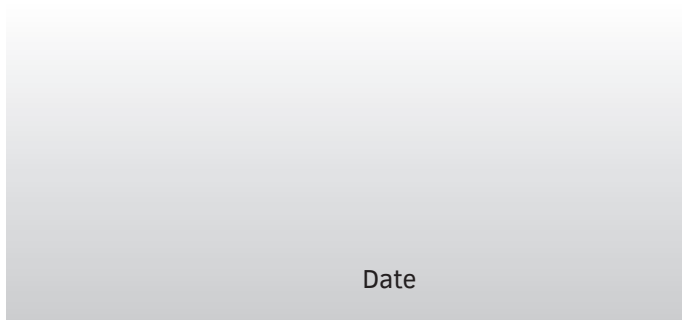

120 Months

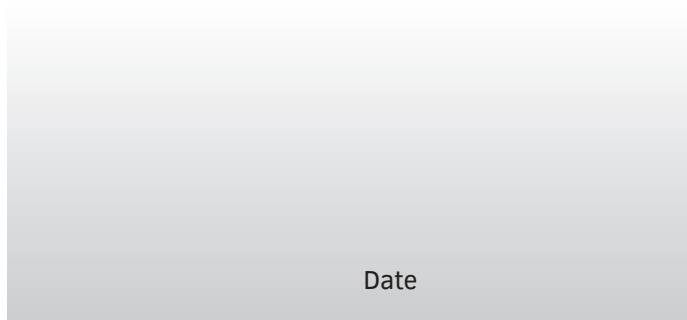

132 Months

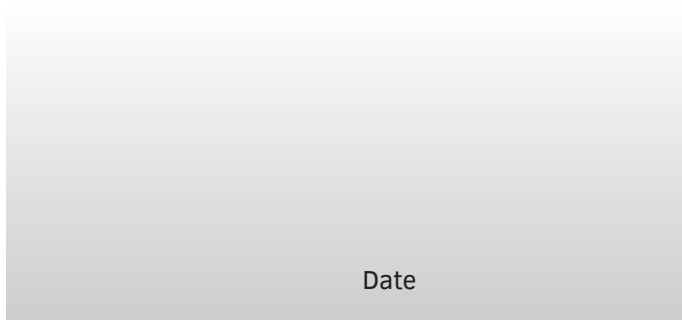

Product Information (\* Compulsory)

If you have registered online, this form is not necessary.  
PLEASE POST THIS COPY TO THE ADDRESS OVERLEAF

*Model No:	
*Product No:	
*Serial No:	
*Date of Purchase:	

Personal Information (\* Compulsory)

*Title		*Forename		*Surname	
*House Number		*House Name			
*Address 1					
*Address 2					
*Town					
*County					
*Postcode					
Home Tel			Mobile Tel		
Email					

Age	18 to 25		26 to 35		36 to 45		46 to 60		61 to 80		81 & over
*Usage	Domestic Use			Commercial/Professional/Hire Use							

\*Dealer Stamp (if available)



\*Selling Retailer (If dealer stamp not available)

*Dealer Name	
*Dealer Address	
*Date of Purchase	

Webb Lawnmowers privacy commitment to machine owners.

The information supplied, helps us to improve the products & services we provide, including information that we believe is relevant to your and/or your machine. We value your trust by giving us this information about yourself and we are committed to protecting your privacy.

Webb, its associated companies, authorised dealers or third parties working on our behalf may wish to contact you regarding **PRODUCT RECALLS** specific to your machine. Please advise how you wish to be contacted for this specific reason only:

Post  Telephone  Email

From time to time Webb, its associated companies, authorised dealers or third parties working on our behalf may wish to contact you regarding our products, services, offers or just opinions, which may be used for marketing, research or analysis purposes.

If you wish to be contacted by any of the following methods, please tick the relevant boxes:

Post  Telephone  Email

You may give Webb Lawnmowers notice in writing at any time that you no longer wish to receive direct marketing communications

Webb Lawnmowers  
Murdock Road  
Dorcan  
Swindon  
Wiltshire  
SN3 5HY