



INSTRUCTION MANUAL

66cm (26") PUSH LAWN SWEEPER

Model No: THPLS -- Product No: 193847002

ASSEMBLY REQUIRED
SAVE THESE INSTRUCTIONS
SPARES & SUPPORT: 01793 333212

IMPORTANT

Please read & understand this manual, paying attention to the safety instructions, before use.
The manufacturer reserves the right to change the product specification & livery according to
continued product improvements.

Images used are for illustration purposes only.

CONTENTS

SPECIFICATION

IMPORTANT INFORMATION

GENERAL SAFETY INSTRUCTIONS

KNOW YOUR PRODUCT

ASSEMBLY

OPERATION & ADJUSTMENT

MAINTENANCE

STORAGE

PARTS DIAGRAM & LIST

ASSEMBLY IS REQUIRED

This product requires assembly before use. See the "Assembly" section for instructions.

Please check that all parts required for the assembly of this spreader are included. If for any reason, you believe a part for the assembly is missing or damaged, please contact us.

**If you require any assistance with regards to the contents or operation of
your machine, please contact us:**

TEL: 01793 333212

(MON – FRI 8.00AM TO 5.30PM EXCL. BANK HOLIDAYS)

EMAIL: customerservice@handydistribution.co.uk

SPECIFICATION

The manufacturer reserves the right to change the product specification and livery according to continued product improvements.

Model	THPLS
Product Number	193847002
Hopper Dimensions (mm)	600 x 560 x 650
Product Dimensions (mm)	1240 x 830 x 770
Wheel Size (mm)	254
Hopper Capacity (Litre)	200



WARNING

Read this instruction manual carefully before operating this machine. Make sure that you are familiar with the controls and properly operate the machine. Following these instructions to reduce the risk of fire, electric shock or personal injury.

IMPORTANT INFORMATION

INTENDED USE

The product is intended for domestic use only. This product is **not** intended for commercial use. Generally acknowledged accident prevention regulations and enclosed safety instructions must be observed. Only perform work described in these instructions for use, any other use is incorrect. The manufacturer will not assume responsibility for damage resulting from such use.

DESIGNED FOR DOMESTIC USE ONLY.











The Push Lawn Sweeper is designed for use in private gardens, but not in public facilities, parks or sports grounds and not for agricultural or forestry use. The product is designed to collect grass, twigs, leaves and other light garden material. This is not a commercial product. Compliance with this manual supplied by the manufacturer is a prerequisite for the proper usage of the machine. The operating manual contains servicing and maintenance instructions as well as directions for use.

TRAINING

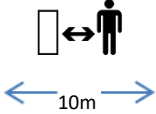
Read the instructions carefully: Be familiar with the controls and the proper use of the equipment. Never allow children or people unfamiliar with these instructions to use the product. Local regulations can restrict the age of the operator. Never operate while people, especially children, or pets are nearby. Keep in mind that the operator or user is responsible for accidents or hazards involving the machine that occur to other people or their property.

GENERAL SAFETY INSTRUCTIONS

Read and understand the owner’s manual and labels affixed to the product. Learn its application and limitations as well as the specific potential hazards. Retain these instructions for future reference. The operator is responsible for following the warnings & instructions in this manual and on the product.

	Read & understand operator’s manual before using the machine. Failure to follow instructions could result in death or serious injury.		DANGER Beware of sharp edges, which can continue to rotate after the product has come to a standstill.
	Wear gloves to protect your hands Wear foot protection		Whenever the machine is in use, we recommend safety glasses are worn to safeguard against flying objects. Face masks are also recommended to avoid inhalation of debris.
	Keep all bystanders & animals at least 10 metres away from the machine during operation. If approached, stop the machine immediately.		Check your machine before using. Keep guards in place and in working order. Frequently check to see that foreign objects are removed from the tool area before operating. Replace damaged, missing or failed parts before using it.
	Safety alert symbol. Used to alert you to potential personal injury hazards. Obey all safety messages that follow this symbol to avoid possible injury.		Indicates an imminently hazardous situation which, if not avoided, will result in serious injury.
	Indicates a potentially hazardous situation which, if not avoided, could result in serious injury.		Indicates a potentially hazardous situation which, if not avoided, may result in minor or moderate injury.
CAUTION	Used without the safety alert symbol, indicates a potentially hazardous situation which, if not avoided, may result in property damage.		Do not expose to rain or damp conditions

STAY ALERT

Do not operate the machine while under the influence of drugs, alcohol, or any medication that could affect your ability to use it properly. Do not use this machine when you are tired or distracted from the job at hand. Be aware of what you are doing at all times. Use common sense.

AVOID DANGEROUS CONDITIONS

Make sure there is adequate surrounding workspace. Cluttered areas invite injuries. Keep your work area clean with sufficient light. Keep the area around the machine clear of obstructions, grease, oil, rubbish and other debris which could cause persons to fall onto moving parts.

INSPECT YOUR MACHINE

Check all bolts, nuts, and screws for tightness before each use, especially those securing guards and drive mechanisms. Vibration during use, may cause these to loosen.

Form a habit of checking to see that all other tools/equipment are removed from the working area before turning it on.

Replace damaged, missing or failed parts before using it. Warning labels carry important information. Replace any missing or damaged warning labels.

DRESS PROPERLY

Do not wear loose clothing, gloves, scarfs, neckties or jewellery (rings, wrist watches), which can be caught in moving parts. Protective electrically non-conductive gloves and non-skid heavy duty footwear are highly recommended when working. Wear a face or dust mask if the operation is dusty. Always wear safety glasses/goggles and/or face shields. Everyday eyeglasses have only impact resistant lenses; they are not safety glasses/goggles. Wear protective hair covering to contain long hair, preventing it from getting caught in machinery.

KEEP BYSTANDERS AND CHILDREN AWAY

Keep unauthorised persons a minimum distance of 10 metres away from the machine. If approached, stop the machine immediately. Do not allow children to handle, climb on or in the machine. Do not carry passengers in the hopper.

DO NOT OVERREACH

Keep proper footing and balance at all times when using the machine. Never stand on the machine. Serious injury could occur if the machine is tipped or if the moving parts are unintentionally contacted. Do not store anything above or near the machine, where anyone might stand on the machine to reach them.

AVOID INJURY FROM UNEXPECTED ACCIDENT

Keep hands & feet out of the way of all moving parts. Do not place any part of your body or any tool e.g. in the machine during operation.

DO NOT FORCE TOOL

Always work within the rated capacity. Do not use the machine for a purpose for which it was not intended. The machine operates better in dry conditions; however it will pick up damp garden debris. The product should not be used in wet conditions, the product may become clogged.

MAINTAIN YOUR MACHINE WITH CARE

Clean the machine immediately after use. Keep the machine clean to ensure it operates to its full & safest performance. When maintaining this machine, only the manufacturer's original replacement parts should be used. The use of non-original manufacturer parts may invalidate your warranty.

PROTECT THE ENVIRONMENT

Take left over materials to an authorised collection point or follow the stipulations in the country where the machine is used. Do not discharge into drains, soil or water.

STORE IDLE EQUIPMENT

When not in use, the machine should be stored in a dry location. Keep the machine away from children and others not qualified to use it.

BE SURE OF FOOTING

Avoid large holes and ditches when using the sweeper. Be careful when operating on steep grades (hill) the sweeper may tip over. Do not push close to creeks, ditches and public highways.

DO NOT TOW

This product should not be attached and towed behind any motorised product.

KNOW YOUR PRODUCT

Read this owner's manual before operating the equipment. Familiarise yourself with the location and function of the controls and features. Save this manual for future reference.

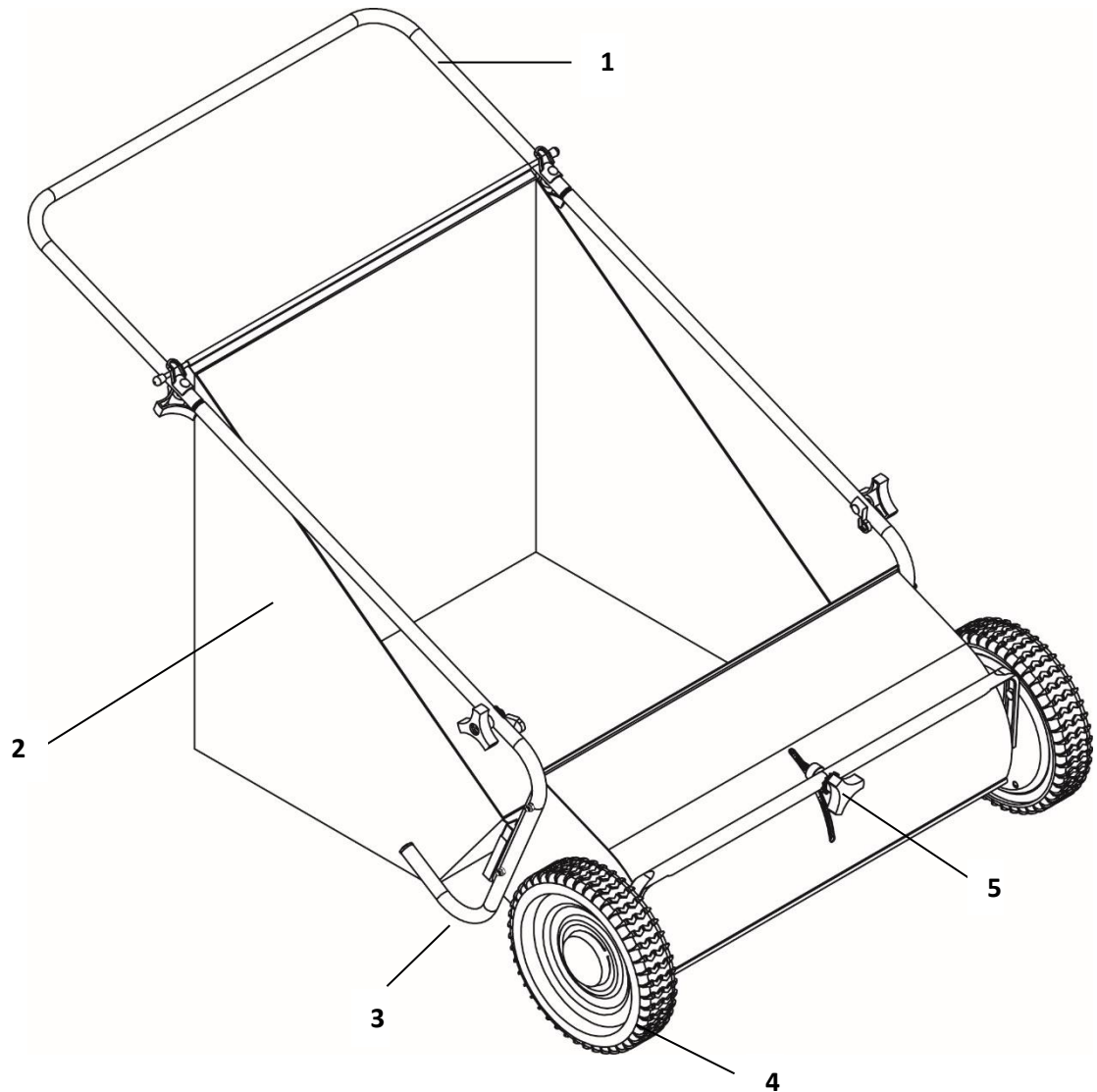

1. Handle – Pushes and moves the sweeper easily.
2. Hopper Bag – Do not exceed the rated load capacity 200 litres.
3. Support Leg – Provides stability to load and sweeper.
4. Wheel – 25.4cm Heavy duty.
5. Hand Knob – Brush height adjuster

ASSEMBLY

Read and follow all instructions for assembly and operation. Failure to assemble this equipment correctly, could result in serious injury to the user, bystanders, or cause equipment damage.

Take all parts out of the carton and inspect components to ensure there are no missing pieces, before starting to assemble the push lawn sweeper, following steps 1 through 5.

TOOLS REQUIRED

10mm Spanners

COMPONENTS

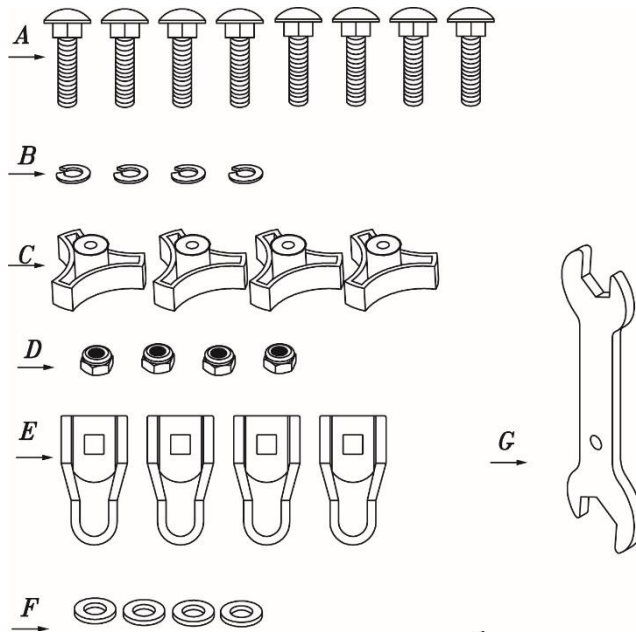

REF.	QTY.	DESCRIPTION
A	8	M6x30 Carriage Bolt
B	4	Ø6 Lock Washer
C	4	Handle Knob
D	4	M6 Nylon Lock Nut
E	4	Bag Rod Clips
F	4	Ø6 Flat Washer
G	1	Wrench

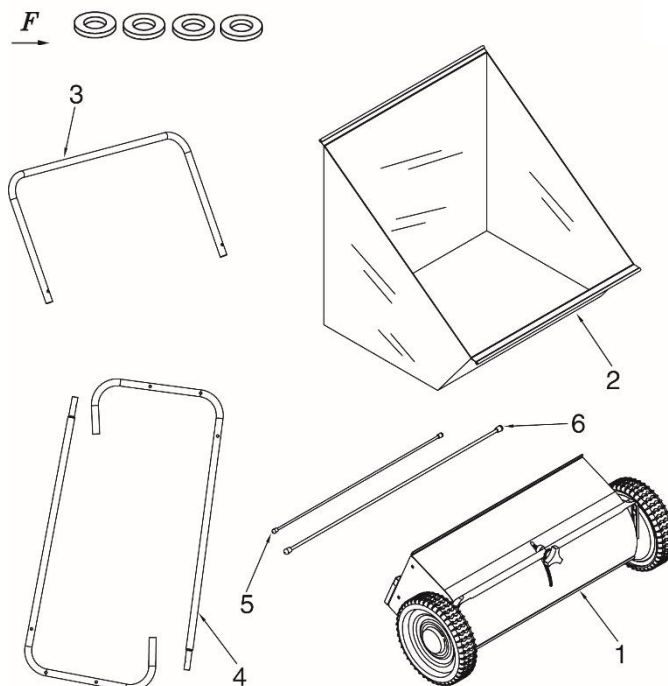

REF.	QTY.	DESCRIPTION
1	1	Sweeper Assembly
2	1	Hopper Bag
3	1	Handle Frame
4	2	Support Leg
5	1	Short Bag Rod with Rubber End Caps
6	1	Long Bag Rod with Rubber End Caps

STEP 1 - INSTALL SUPPORT LEGS TO SWEEPER HOUSING

Attach the support leg to the sweeper assembly and secure with M6 x 30 carriage bolt and M6 nylon lock nut (Fig. 1). Do not fully tighten yet. Repeat for the other side.

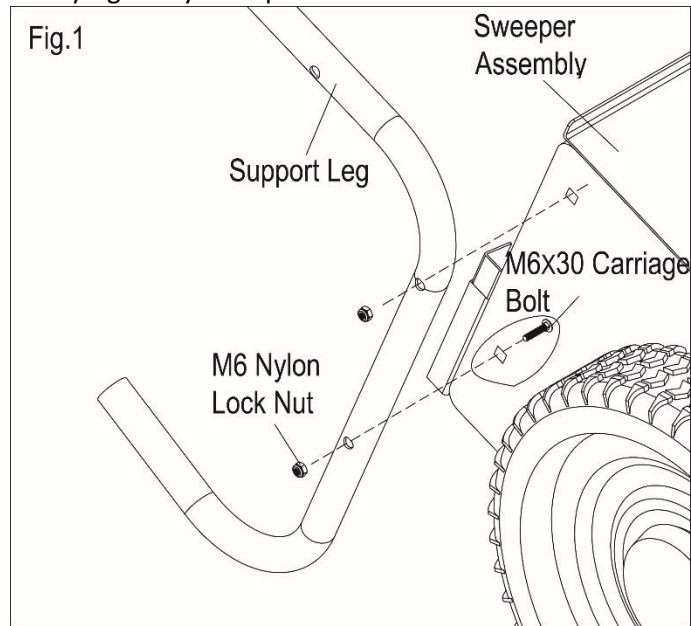

STEP 2 - ATTACH HANDLE TO SUPPORT LEGS

Assemble the handle frame to the support legs. Align the holes in the handle frame and support legs (Fig. 2).

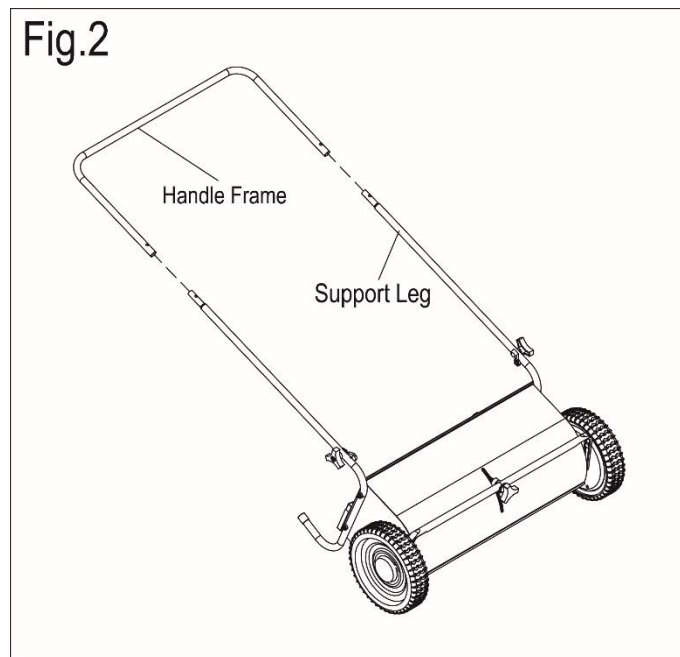

Secure the support legs & handle frame with two M6 x 30 carriage bolts, bag rod clips, flat washers, lock washers, and handle knobs (Fig. 3).

Fully tighten all hardware in steps 1 & 2.

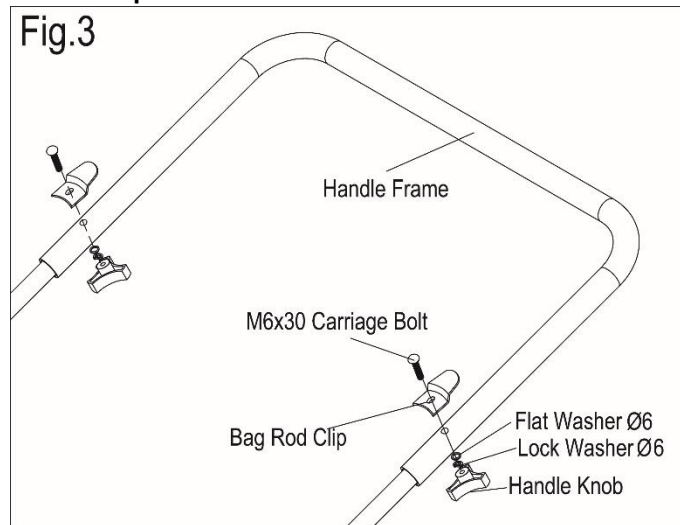

STEP 3 - ATTACH BAG ROD CLIPS

Put two bag rod clips on the inside of each support leg, secure with M6 x 30 carriage bolt, a flat washer, a lock washer, and a handle knob (Fig. 4).

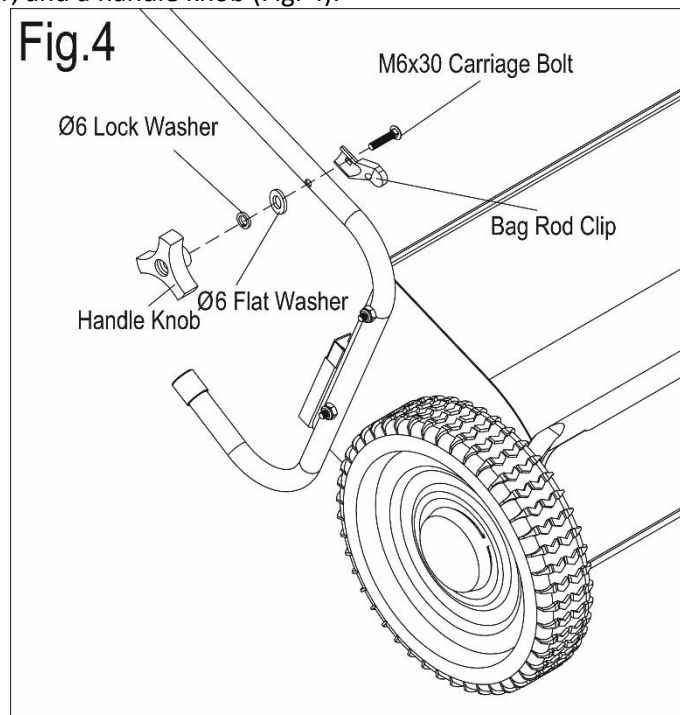

STEP 4 - ASSEMBLE HOPPER BAG HARDWARE

Slide the long bag rod through the top of the hopper bag along the stitched area. Slide the short bag rod through the bottom of the hopper bag along the stitched area. (Fig. 5).

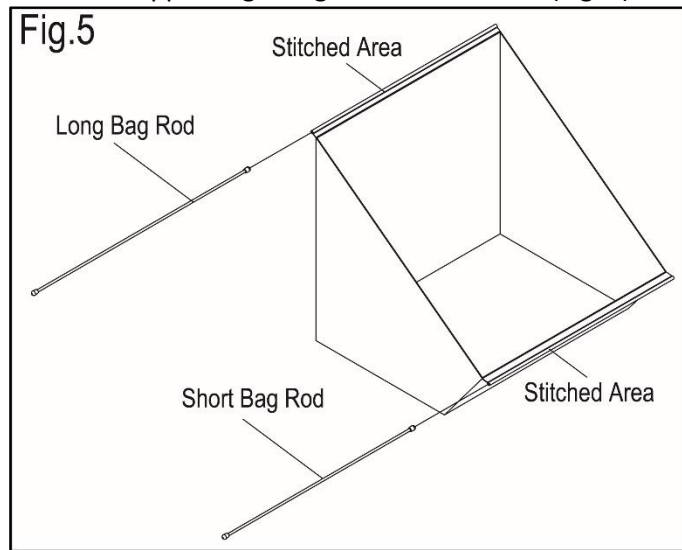

STEP 5 - ATTACH HOPPER BAG TO SWEEPER

Place the hopper bag assembly on the sweeper & frame assembly by inserting the long bag rod in to the two rod clips on the handle frame, and the short bag rod into the two openings on each side of the housing assembly. Hook the plastic straps on the bag flaps under the bag clips on the support legs (Fig. 6).

Make sure all hardware and the hopper bag is installed correctly before operating the sweeper.

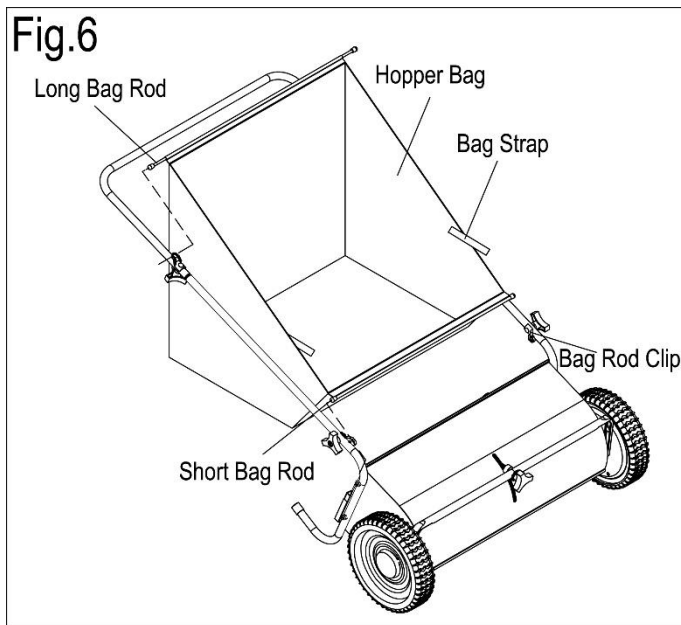

Long Bag Rod Location

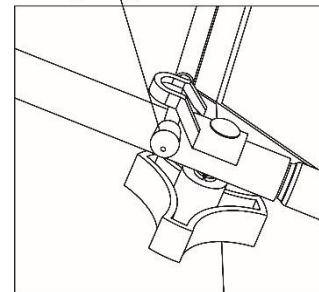

Short Bag Rod Location

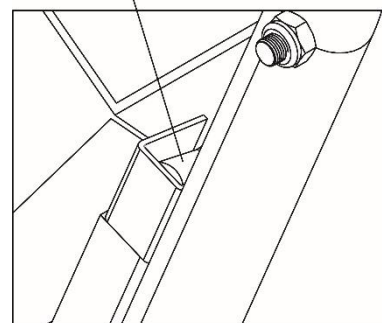

OPERATION / ADJUSTMENT



The product must only be put into operation if no defects are found. It is crucial that defective parts are replaced before the product is used again. Check the safety equipment & the safe condition of the product: Check all parts to make sure that they fit tightly. Check whether there are any visible defects: broken parts, cracks, etc.

BRUSH HEIGHT ADJUSTMENT

Unlock the height adjustment lock by turning the locking knob counterclockwise (Fig. 7).

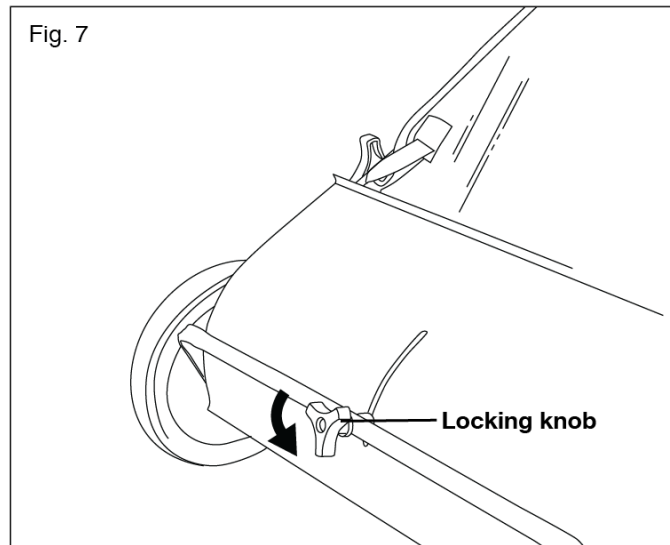

Use hand to hold the handle (see arrow) to adjust the brush height by lifting the handle up and down, several times. Tighten the Handle Knob at your desired height.

Note: sometimes you may need your hand to slide the height adjustment tube.

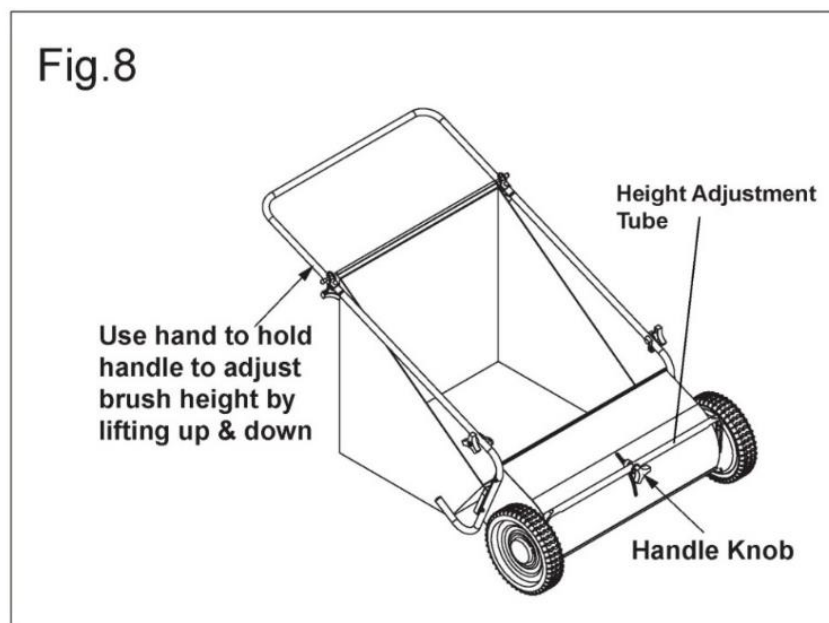

Adjust the brush scale according to the height of handle position. Lock the height lock by turning the locking knob clockwise.

Scale	Handle Position (cm)
2	110
1	100
0	80
-1	65
-2	55

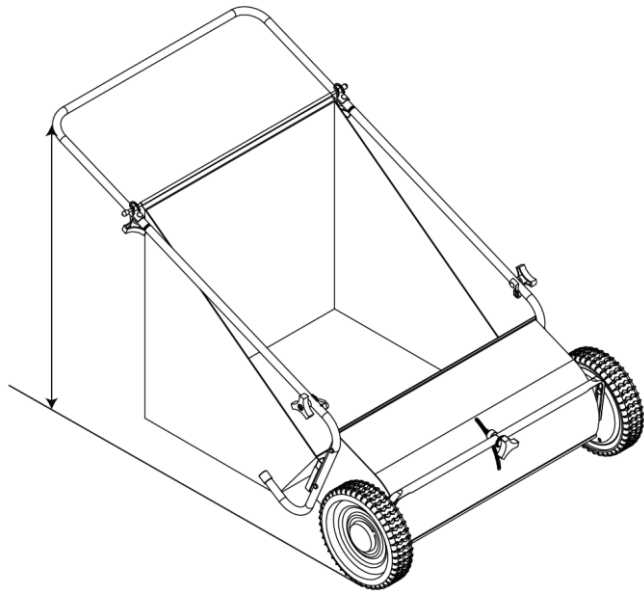

BASIC SWEEPING METHOD

Push sweeper forward at normal walking speed; it does not operate when pulled backwards.

NOTE: Always mow the grass to an even height before sweeping for best results collecting grass.

EMPTYING HOPPER BAG

To dump the hopper bag, tip the sweeper forward allowing the material to fall out.

You can also take the hopper bag off the sweeper to empty.



WARNING!

Always empty the hopper bag after each use. Damp or wet grass or leaves will cause damage to hopper if stored for an extended period of time.



WARNING!

DO NOT empty or unload the sweeper too close to fire!

The brushes and the hopper bag can be destroyed by excessive heat of flame.

MAINTENANCE

CLEANING

After each use, empty and clean the hopper. Rinse/dry inside and outside of the sweeper after each use.

STORING

Before storing, ensure that the machine is clean and dry. Store in a dry or protected area and coat exposed metal with a glossy enamel spray paint to touch up scratched or worn painted areas.

CHECK ALL NUTS, BOLTS AND FASTENING

Before each use, check all fastenings are tight & secure.

ONLY USE MANUFACTURER APPROVED PARTS

If a part needs replacing, only use the manufacturer's original parts. Non-original replacement parts will invalidate your warranty and may result in a safety hazard or poor operation.

NEVER EXCEED CAPACITY

Never exceed the hopper load capacity rating of 200 Litres, it will damage the hopper bag.

LUBRICATION - ANNUALLY CLEAN OUT AND LIGHTLY LUBRICATE PARTS.

The bearings in the sweeper have been pre-lubricated at the factory. However, it's recommended that a few drops of light oil should be added to the brush shaft bearings twice a year. Also, the gear should be cleaned every two years. After cleaning apply an even coat of light general purpose grease. Follow below steps to action:

Use a screw driver to pop off the hub cap (Fig. 9).

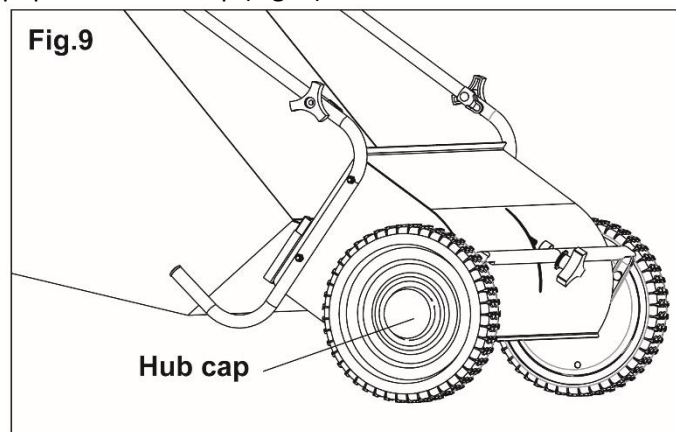

To remove the wheel, take out the circlip & the flat washer; you will see the gear and the shaft (Fig. 10).

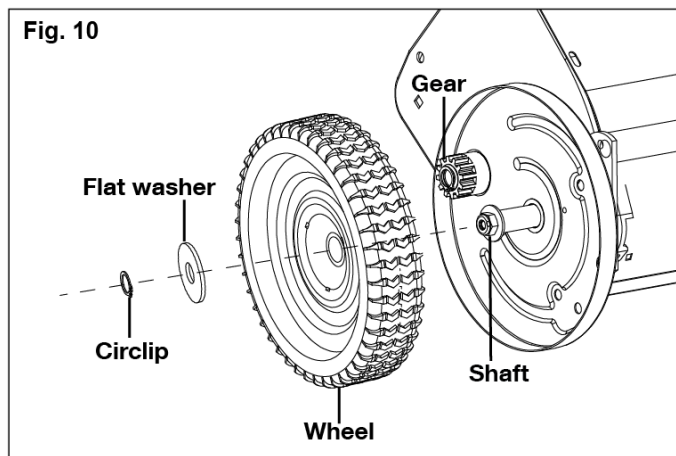

Remove the circlip on the gear, the gear can be taken off easily (Fig. 11). Clean the gear and lubricate the shaft as needed, then reassemble the wheel in a reverse sequence.

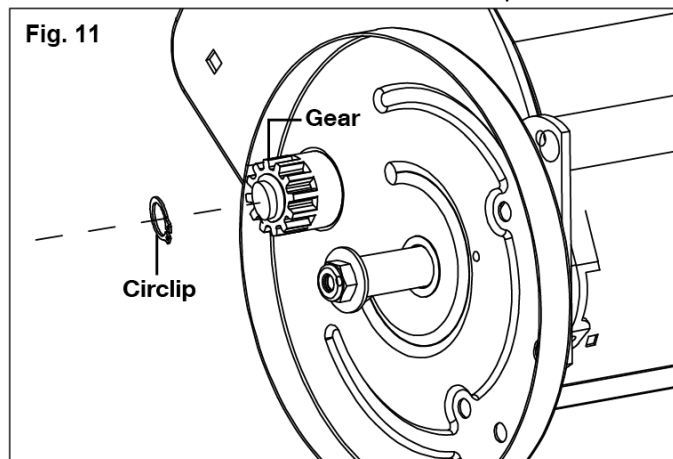

BRUSH REPLACEMENT

Before replacing the brush, remove the hopper bag from the sweeper, and flip the sweeper over. Remove all the nuts and bolts on the brush retainers, used for securing the brushes (Fig. 12).

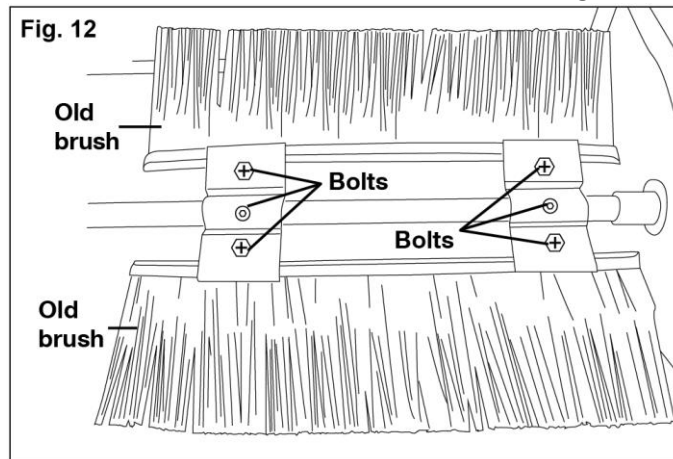

Remove the old brushes, the long brush retainer, and the short brush retainers from the sweeper (Fig. 13).

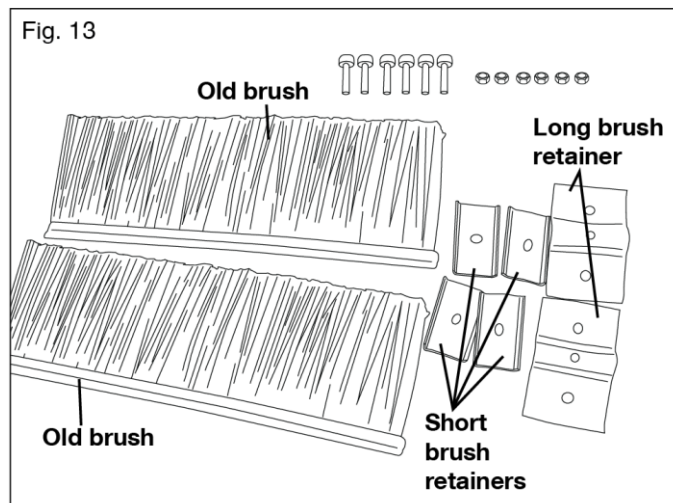

Insert new brushes between the long brush & the short brush retainers; fix with M6 nuts and hex bolts (Fig. 14).

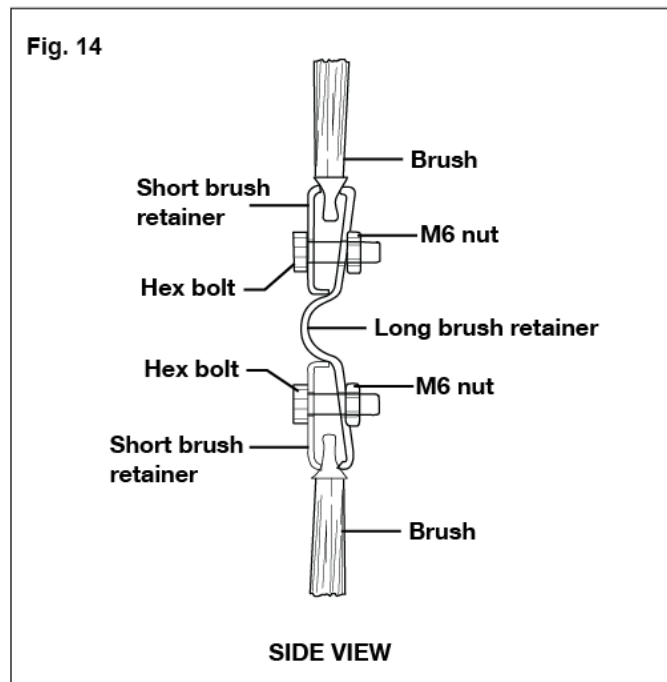

Fit the brush assembly onto the brush shaft; fix with a M5 nut and a M5 bolt (Fig. 15). Repeat the steps to install the remaining brush.

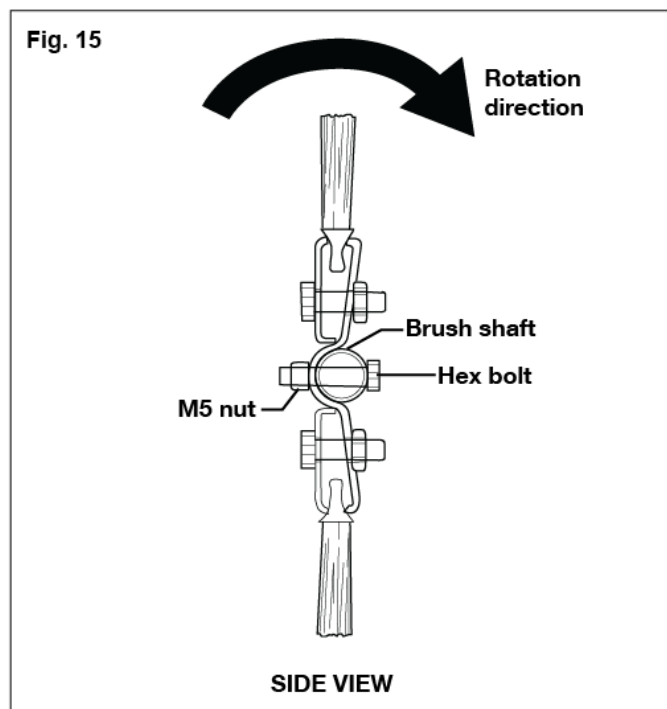

NOTE: The two sets of brushes should remain vertical to each other after assembly, as shown (Fig. 16).

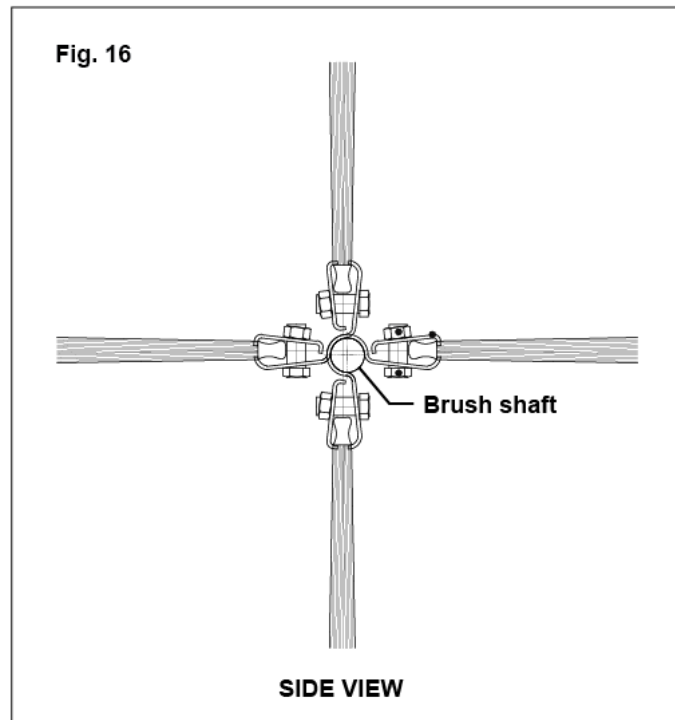

STORAGE

Store indoors or in protected area during severe weather and winter months.

Never allow anything left in the hopper bag to remain for an extended period of time.

Before storing, make sure the sweeper is dry and clean.

Never allow items to be stored above the sweeper, which could step on the sweeper to reach.

PARTS DIAGRAM

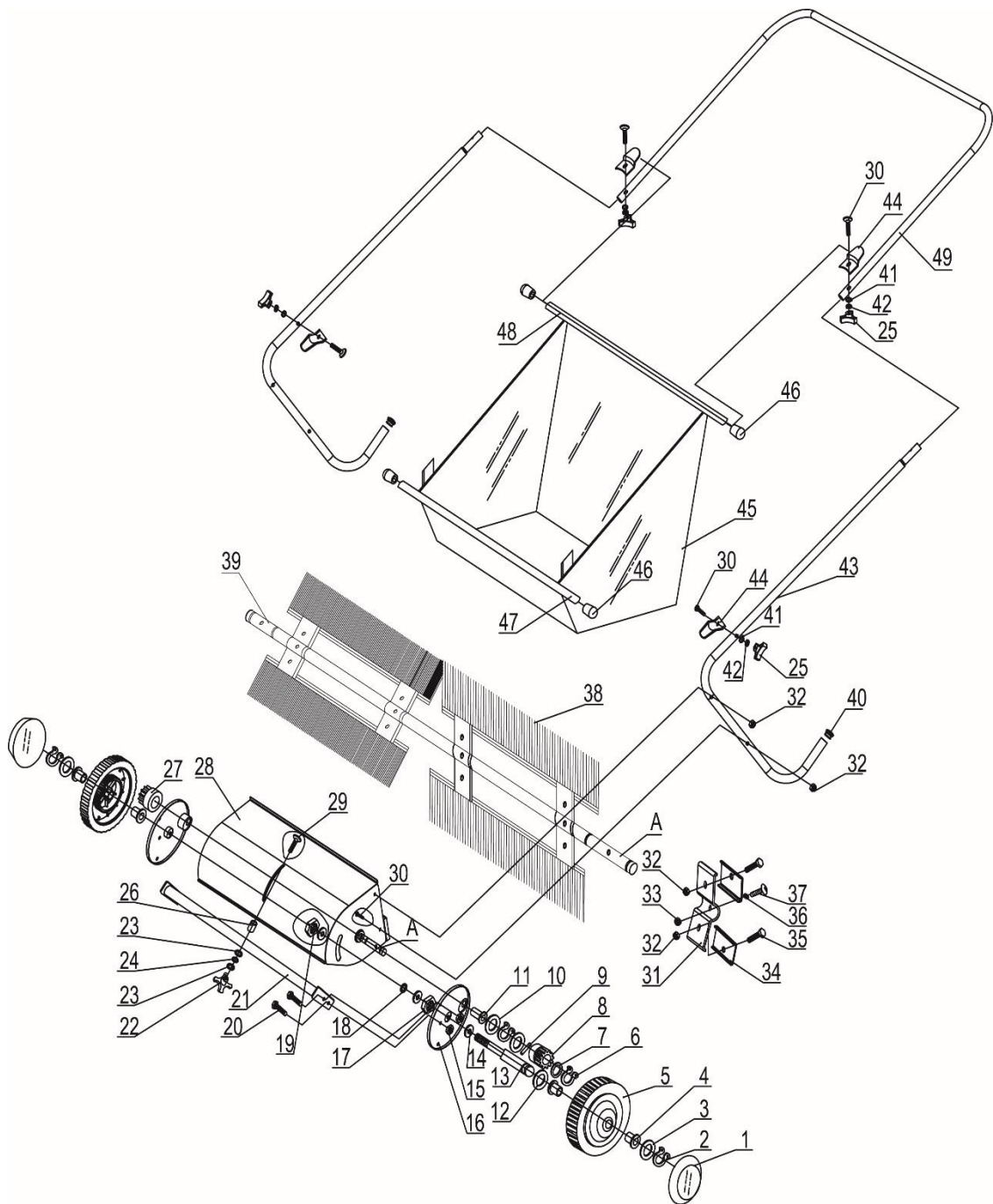

NOTE: Parts Lists are supplied for information purposes only, not all parts are stocked individually & we recommend you contact our Spares Team on 01793 333212 for expert advice.

PARTS LIST

REF#	HANDY PART NO.	DESCRIPTION	QTY
1	TH231-N28000032	Plastic Cover for Wheel	2
2	TH231-930416000FH	Back Ring Ø16	2
3	TH231-930716000DX	Flat Washer Ø16	2
4	TH231-NS260000004	Bushing	4
5	TH231-N28020000	Wheel	2
6	TH231-930415000FH	Back Ring Ø15	4
7	TH231-N28000037FH	Washer for Adjustment B	2
8	TH231-N28000030	Pinion Gear L.H.	1
9	TH231-940106020	Pin of Gear	2
10	TH231-N28000029FH	Washer for Adjustment A	4
11	TH231-NS260000008	Bearing for Brush	2
12	TH231-NS260000006	Washer for Adjustment F	2
13	TH231-NS260000009DX	Wheel Axle	2
14	TH231-930210000DX	Big Washer Ø10	6
15	TH231-920608000DX	Nylon Lock Nut M8	4
16	TH231-NS260000005	Dust Cover Assembly	2
17	TH231-920110000DX	Hex Nut M10	2
18	TH231-N28000036DX	Endplate Bushing	2
19	TH231-920610000DX	Nylon Lock Nut M10	2
20	TH231-910108012DX	Hex Bolt M8x12	4
21	TH231-NS260000001	Connect Tube	1
22	TH231-N28070000	Knob	1
23	TH231-930208000DX	Big Flat Washer Ø8	2
24	TH231-931008000FH	Wave Washer	1
25	TH231-NS260000015	Handle Knob	4

REF#	HANDY PART NO.	DESCRIPTION	QTY
26	TH231-NS260000014	Cushion Washer	1
27	TH231-N28000012	Pinion Gear R.H.	1
28	TH231-NS260010000	Housing Assembly	1
29	TH231-911408055DX	Carriage Bolt M8x55	1
30	TH231-911406030DX	Carriage Bolt M6x30	8
31	TH231-N28030001DX	Brush Clamp	4
32	TH231-920606000DX	Nylon Lock Nut M6	12
33	TH231-920605000DX	Nylon Lock Nut M5	4
34	TH231-N28030002DX	Brush Retainer	8
35	TH231-910206020DX	Hex Bolt M6x20	8
36	TH231-931605000FH	Star Washer Ø5	4
37	TH231-910205025DX	Hex Bolt M5x25	4
38	TH231-NS260021000	Brush	4
39	TH231-NS260000007DX	Brush Axle	1
40	TH231-N99000011	Plug	2
41	TH231-930106000DX	Flat Washer Ø6	4
42	TH231-930606000DX	Lock Washer Ø6	4
43	TH231-NS260000002	Support Leg	2
44	TH231-NS260000003	Bag Rod Clip	4
45	TH231-NS260030000	Hopper Bag	1
46	TH231-NS260000011	Plastic End Cover	2
47	TH231-NS260000012DX	Short Bag Rod	1
48	TH231-NS260000013DX	Long Bag Rod	1
49	TH231-NS260000010	Handle Frame	1

GJ HANDY & CO LTD USER WARRANTY POLICY

Users Statement of Warranty

Each new machine is warranted against defective material or assembly of material under normal usage. The warranty applies to the original purchaser and covers faulty parts and the labour involved in replacing and repairing those parts, which are of original manufacture.

Period of Warranty

All Webb & Webb Pro machines plus Sanli engines.

- a) 2 years from the original date of sale to the first domestic user.
- b) 90 days from the original date of sale to the professional/commercial user.
- c) 90 days from the original date of sale when used for hire.
- d) A reduced warranty period of 90 days applies to those items which are subject to normal wear and tear (e.g. but not limited to wheels, tyres, cutter bars, cylinders, blades, belts, cables, grass bags, spark plugs).
- e) Engines as per the manufacturer's warranty statement which will be supplied with the machine.
- f) 90 days from the original date of purchase for Replacement Spare Parts (unless normal wear & tear component, which are covered for 30 days).
- g) All machines' must be serviced within the first 12 months from the original date of purchase to comply with the warranty, failure to do so will invalidate the 2nd year of the warranty.

All Handy, Mowerland and Q-Garden products.

- a) 1 year from the original date of sale to the first domestic user.
- b) 90 days from the original date of sale to the professional/commercial user.
- c) 90 days from the original date of sale when used for hire.
- d) A reduced warranty period of 90 days applies to those items which are subject to normal wear and tear (e.g. but not limited to wheels, tyres, cutter bars, cylinders, bottom blades, belts, cables, collection bags, spark plugs).
- e) Engines as per the manufacturer's warranty statement which will be supplied with the machine.
- f) 90 days from the original date of purchase for Replacement Spare Parts (unless normal wear & tear component, which are covered for 30 days).

All warranty repairs must be undertaken by an authorised service dealer. These dealers have been accredited by GJ Handy & Co Ltd and agree to only use genuine parts and follow our repair procedures.

GJ HANDY & CO LTD USER WARRANTY POLICY

Not covered by this warranty

- a) The warranty policy does not cover any depreciation or damages caused by ordinary wear, rusting or corrosion, lack of correct maintenance or operation, misuse, abuse, lack of transportation or accident.
- b) The warranty policy does not cover any costs necessary for the standard periodic maintenance services instructed by the operator's manual, or service parts replacement which would include oil, filters, tyres, belts, brake linings, fuses, blades, seals and other service parts unless it can be proven that the item has evidence of faulty manufacture.
- c) The warranty policy will not cover failure or damage caused as a result of parts or accessories being modified without the written approval of GJ Handy & Co Ltd.
- d) The warranty policy will not cover the unit if non-genuine parts have been fitted and as a result damage has occurred to the unit.
- e) The warranty policy is non-transferable and is only applicable to the original purchaser.

Disclaimer

- a) This warranty is only a remedy for defect of products. GJ Handy & Co Ltd will never warranty in terms of the merchantability or the fitness for a particular purpose.
- b) No person is authorised to make any warranties, representations or promises, expressed or implied, on behalf of GJ Handy & Co Ltd, or to modify the terms conditions or limitation of this warranty policy in any way.
- c) Neither GJ Handy & Co Ltd nor any company affiliated with GJ Handy & Co Ltd shall be liable in any event or manner whatsoever for incidental or consequential damages or injuries, including, but not limited to, loss of crops, loss of profit, out of pocket expenses or profits, rental of substitute equipment or other commercial losses.

General

- a) Most warrantable failures show up within the first few weeks of use. These failures are usually straightforward and warranty assessment is relatively easy.
- b) Failures relating to cutter decks and belts need careful investigation, as the cause may not always be straightforward. Look for damage to blades and pulleys especially when the cutter belt or blade boss have snapped or cracked as this could be due to impact damage.
- c) Customers should always refer to the operator/instruction manual when any disputed problem arises, you will find most areas covered within the manual.

NOTES

For spares or support of your Handy product,
please contact us:

Tel: 01793 333212

(Mon – Fri 8.00am to 5.30pm excl. Bank Holidays)

Email: customerservice@handydistribution.co.uk

To see our range of garden machinery & equipment visit:

www.thehandy.co.uk

Making gardening easier & affordable since 1938

Distributed by Handy Distribution, Murdock Road, Dorcan, Swindon, SN3 5HY