



INSTRUCTION MANUAL

TOWED ROLLER

MODEL NO: THTD -- PRODUCT NO: 1938118001

EN - ORIGINAL INSTRUCTIONS

ASSEMBLY REQUIRED

SAVE THESE INSTRUCTIONS

SPARES & SUPPORT: 01793 333212

FOR YOUR SAFETY

Please read & understand this manual, paying attention to the safety instructions, before use.
Incorrect use of the product could put the operator or machine in danger.
Whilst every effort has been made to ensure the accuracy of information contained in this manual, our policy of continuous improvement determines the right to make modifications without prior warning.
Images used are for illustration purposes only

Copyright Notice

Copyright © Handy Distribution

Permission is granted to reproduce this publication for personal & educational use only.

Commercial copying, redistribution, hiring or lending is prohibited.

No part of this publication may be stored in a retrieval system or transmitted in any other form or means without written permission from Handy Distribution.

In all cases this copyright notice must remain intact.

CONTENTS

SPECIFICATIONS

IMPORTANT INFORMATION

GENERAL SAFETY INSTRUCTIONS

COMPONENTS

ASSEMBLY

OPERATION

CLEANING

STORAGE & TRANSPORT

PARTS DIAGRAM & LIST

WARRANTY

ASSEMBLY IS REQUIRED

This product requires assembly before use. See the "Assembly" section for instructions.

Please check that all parts required for the assembly of this spreader are included. If for any reason you believe a part for the assembly is missing or damaged, please contact us.

If you require assistance with regards to the contents or operation of the machine, please contact us:

TEL: 01793 333212

EMAIL: customerservice@handydistribution.co.uk

(MON – FRI 8.00AM TO 5.30PM EXCL. BANK HOLIDAYS)

SPECIFICATIONS

The manufacturer reserves the right to change the product specification and livery according to continued product improvements.

Model Number	THTGR
Product Number	1938103001
Working Width	980mm
Drum Diameter	400mm
Product Dimensions	W1050 x L1070 x H400mm
Drum Capacity (Water)	120L
Drum Capacity (Sand)	113.2L
Weight	G.W 24.2kg - N.W 21.5kg
Weight (Filled with Water)	121kg
Weight (Filled with Sand)	219kg

IMPORTANT INFORMATION

INTENDED USE

The product is intended for domestic gardens for the rolling soil, grass or and garden. It may not be filled with stones, glass, metal, bones, plastics or material scraps.

This product is not intended for commercial use. Generally acknowledged accident prevention regulations and enclosed safety instructions must be observed. Only perform work described in these instructions for use, any other use is incorrect. The manufacturer will not assume responsibility for damage resulting from such use.

GENERAL SAFETY INSTRUCTIONS

Read and understand the owner's manual and labels affixed to the product. Learn its application and limitations as well as the specific potential hazards. Retain these instructions for future reference. The operator is responsible for following the warnings & instructions in this manual and on the product.

READ THE MACHINE MANUAL

Read the vehicle owner's manual and vehicle safety rules to know how to operate the vehicle before using this equipment.

STAY ALERT

Do not operate the machine while under the influence of drugs, alcohol, or any medication that could affect your ability to use it properly. Do not use this machine when you are tired or distracted from the job at hand. Be aware of what you are doing at all times. Use common sense.

USERS

Never allow children to operate the towing vehicle or roller. Do not allow adults to operate without having read these instructions.

PASSENGERS

Do not allow anyone to ride or sit on the roller or frame or on the towing vehicle.

BEWARE BYSTANDERS/PETS

Keep the area of operation clear of all persons, particularly children and pets.

HANDLE WITH CARE

Always handle with care and wear sturdy footwear and protective gloves when operating this roller.

AVOID DANGEROUS CONDITIONS

Ensure there is adequate surrounding workspace. Cluttered areas invite injuries. Keep your work area clean with sufficient light. Keep the area around the machine clear of obstructions, grease, oil, rubbish & other debris which could cause persons to fall onto moving parts.

INSPECT YOUR MACHINE

Check all bolts, nuts & screws for tightness before each use, especially those securing guards & drive mechanisms. Vibration during use, may cause these to loosen. Replace damaged, missing or failed parts before using.

Warning labels carry important information.

Replace any missing or damaged warning labels.

CRUSH AND CUT HAZARDS

Always keep your hands and feet clear from moving parts while operating the equipment. Always keep the work area clean and clear when operating.

CONDITIONS

Always operate up and down a slope, never across the face of a slope. This equipment should be operated at reduced speed on rough terrain, along creeks and ditches and on hillsides, to prevent tipping and loss of control. Do not drive too close to a creek or a ditch. Do not tow this equipment on a highway or any other public thoroughfare. Always begin with the transmission in first (low) gear & the engine at low speed. Gradually increase the speed as conditions permit. The vehicle braking and stability may be affected with the roller attached. Be aware of changing conditions on slopes. Refer to safety rules in the vehicle owner's manual, concerning safe operation on slopes.

DRESS CORRECTLY

Do not wear loose clothing, gloves, scarfs, neckties or jewellery (rings, wrist watches), which can be caught in moving parts.

DO NOT OVERREACH

Always keep proper footing and balance when using the machine. Never stand on the machine. Serious injury could occur if tipped or moving parts are unintentionally contacted. Do not store anything above or near the machine, someone might stand on the machine to reach them.

AVOID INJURY FROM UNEXPECTED ACCIDENT

Keep hands & feet out of the way of all moving parts. Do not place any part of your body or any tool in moving parts during operation.

DO NOT FORCE TOOL

Always work within the rated capacity. Do not operate for a purpose for which it was not intended.

MAINTAIN YOUR MACHINE WITH CARE

Clean the machine immediately after use. Keep the machine clean to ensure it operates to its full & safest performance. When maintaining this machine, only the manufacturer's original replacement parts should be used. The use of non-original manufacturer parts may invalidate your warranty.

STORE IDLE EQUIPMENT

When not in use, the machine should be stored in

a dry location, out of direct sunlight. Keep the machine away from children & others not qualified.

OPERATION SPEED

Do not exceed 6mph, to avoid personal injury and/or equipment damage.

FILLING THE DRUM - WATER

When filling the drum with water, do not connect a hose pipe via a fixed coupling, which could cause a build-up of pressure within the drum. Always empty the roller drum after you have finished using it, in order to prevent it from rusting and also protect from sub-zero temperatures. Anti-freeze can be used for further protection.

FILLING THE DRUM – SAND

When filling the drum with sand, it is recommended a large funnel is used to ease the filling method.

SAFETY SYMBOLS



Read & understand the operator's manual before using the machine. Failure to follow instructions could result in death or serious injury.



Risk of slicing. Keep hands out of the way of all moving parts.



Wear protective gloves to protect your hands



Wear foot protection



Safety alert symbol. Used to alert you to potential personal injury hazards. Obey all safety messages that follow this symbol to avoid possible injury.



DANGER

Indicates an imminently hazardous situation which, if not avoided, will result in serious injury.



WARNING

Indicates a potentially hazardous situation which, if not avoided, could result in serious injury



CAUTION

Indicates a potentially hazardous situation which, if not avoided, may result in minor or moderate injury.

CAUTION



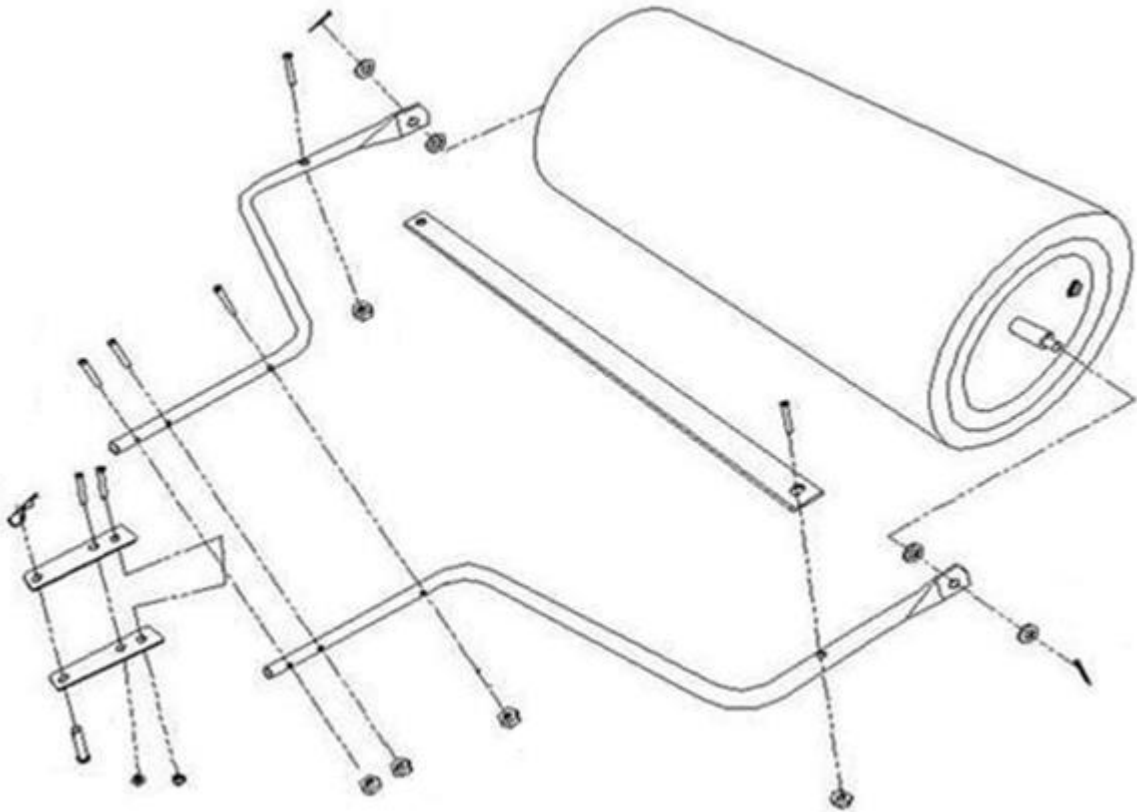

Used without the safety alert symbol indicates a potentially hazardous situation which, if not avoided, may result in property damage.

COMPONENTS

Contents: 2x Pull Bars, Scraper Bar, Drum, Fill/Drain Plug with Seal, Fixing Kit (Incl. R-Pin, Tow Bolt, 3x 70mm Bolt, 2x Coach Bolt, 2x Bolt 55mm, 2x Washer, 2x Split Pin, 8x Nut, 2x Plastic Bush, 2x Clevis Jaws)



ASSEMBLY

	<p>Insert a Plastic Bush onto the inside of the Drawbar.</p>
	<p>Place the Bush and Drawbar onto the Roller Shaft. The Bush should be between the Drawbar and the Roller Shaft, as shown.</p> <p>Secure with a Washer and Split Pin. Repeat for the other side.</p>
	<p>Loosely fit the three 70mm Bolts and Nuts through both parts of the Drawbar, as shown.</p>
	<p>Fit the two Clevis Jaws to the Drawbar using two 55mm Bolts and Nuts, ensuring that the Bolts are between the two front 70mm Bolts and the two Drawbar parts, as shown.</p>

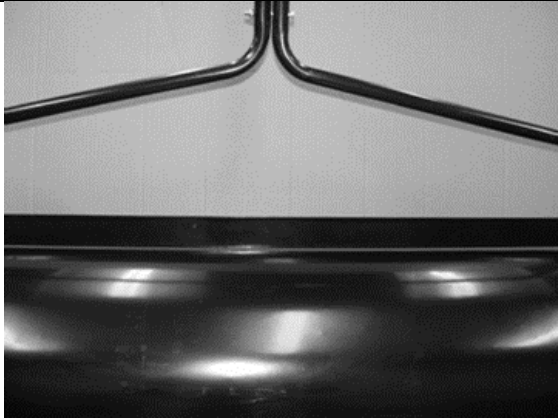

Fit the Scraper to the Drawbar assembly using the 40mm Coach Bolts and Nuts. Ensure that the scraper just clears the Roller before tightening the Nuts.

Tighten all Nuts and Bolts.

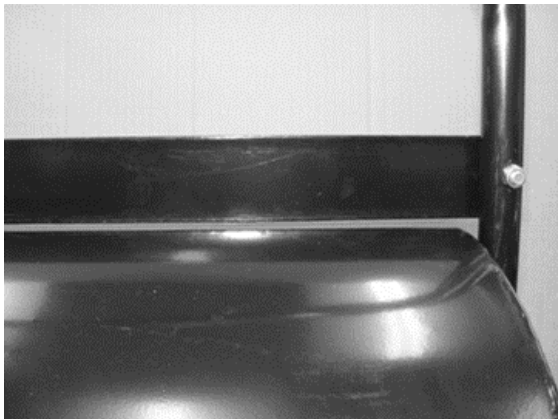

Insert the Towing Pin and secure with the R-Clip, as shown.

OPERATION / ADJUSTMENT



DANGER

The product must only be put into operation if no defects are found. It is crucial that defective parts are replaced before the product is used again. Check the safety equipment and the safe condition of the product: Check all parts to make sure that they fit tightly. Check whether there are any visible defects: broken parts, cracks, etc.



DANGER

The product must only be put into operation if no defects are found. It is crucial that an defective parts are replaced before the product is used again.

Check the safety equipment and the safe condition of the product:

- Check whether the drum is secure in it's fixings.
- Check all parts to make sure that they fit tightly.
- Check whether there are any visible defects: broken parts, cracks, etc.

Never use the roller up and down slopes. Always work across a slope, ensuring you have a stable footing.

The Roller may be filled with water or sand by removing the Fill/Drain plug, filling with the required amount and replacing the plug. If using water in the Roller you may want to add anti-freeze during cold weather, however the roller still needs to be drained before winter storage, in order to avoid frost damage, even if you have used anti-freeze

MAINTENANCE

LUBRICATE

Maintenance spray or multi-purpose grease can be applied to the wheel axle prior to long-term storage.

CLEANING

After each use thoroughly wash the machine with a stiff brush.

STORING

Before storing, ensure that the machine is clean and dry.

Store in a dry or protected area and coat exposed metal with light oil when not in use.

CHECK ALL NUTS, BOLTS AND FASTENING

Before each use check all fastenings are tight & secure.

APPEARANCE

If rust appears on the shield or spring tines, sand lightly and coat with enamel paint.

NEVER EXCEED LOAD CAPACITY

To avoid damaging the spreader, never exceed the rated load capacity of 45.5kg (100lb)

ONLY USE MANUFACTURER APPROVED PARTS

If a part needs replacing, only use the manufacturer's original parts. Non-original replacement parts will invalidate your warranty and may result in a safety hazard or poor operation.

STORAGE & TRANSPORT

STORAGE



WARNING

Make sure that unauthorised persons do not have access to the device!

- Store the machine in a dry place
- Store away from direct sunlight
- Do not store anything above or near the machine, where anyone might stand on the machine to reach them.
- Keep the machine away from children and others not qualified to use it.

TRANSPORT

- Secure the device against slipping.
- When shipping, use the original packaging if possible.

PARTS DIAGRAM & LIST

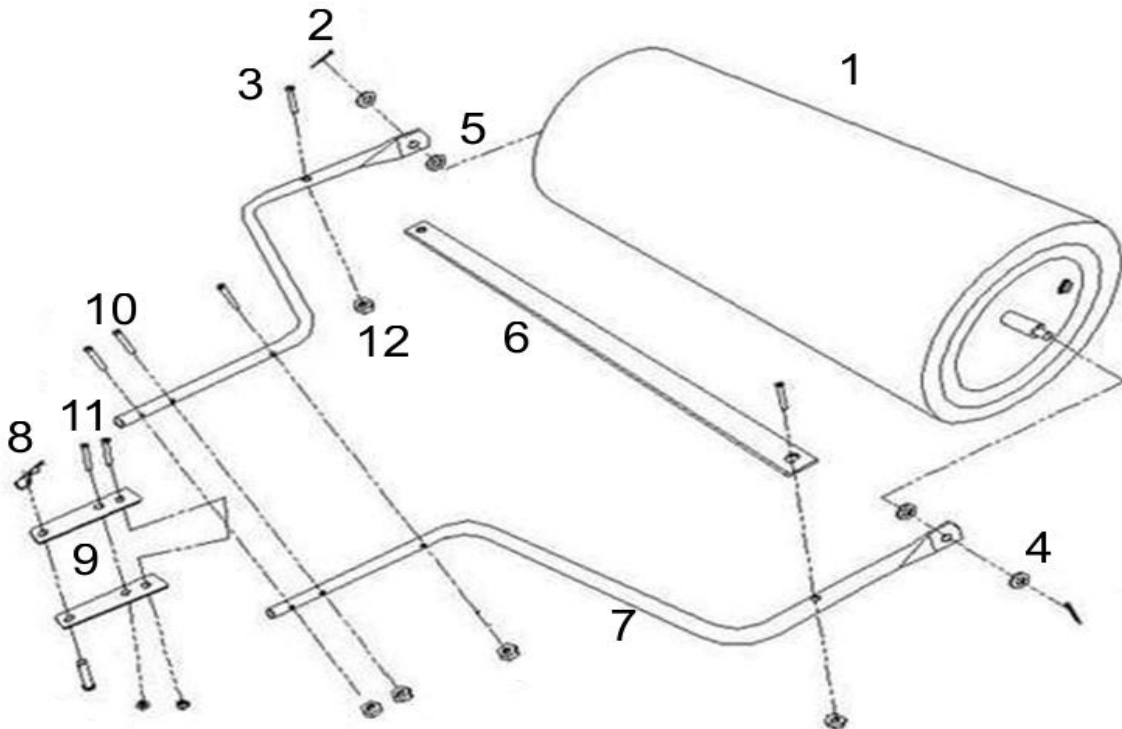

Item No	Part No	Description	Qty
1	TH160-ROLLER	Drum	1
2	TH166-7	Split Pin	2
3	TH160-4	Coach Bolt 40mm	2
4	TH160-6	Washer	2
5	TH160-9	Plastic Bush	2
6	TH160-13	Scraper Bar (Gun Metal)	1
7	TH160-11	Drawbar (Gun Metal)	2
8	TH160-1	R-Pin	1
9	TH160-12	Clevis Jaw (Gun Metal)	2
10	TH160-3	Bolt 70mm	3
11	TH160-5	Bolt 55mm	2
12	TH160-8	Nut	7
	TH160-10	Fixing Kit (Incl. 2, 3, 4, 5, 8, 10, 11, 12)	

NOTE: Parts Lists are supplied for information purposes only, not all parts are stocked individually & we recommend you contact our Spares Team on 01793 333212 for expert advice.

GJ HANDY & CO LTD USER WARRANTY POLICY

Users Statement of Warranty

Each new machine is warranted against defective material or assembly of material under normal usage. The warranty applies to the original purchaser and covers faulty parts and the labour involved in replacing and repairing those parts, which are of original manufacture.

Period of Warranty

Webb (excludes Electric Handheld, Dynamic, Heritage, Legacy), Webb Pro, Sanli Engine

- a) 2 years from the original date of sale to the first domestic user.
- b) 90 days from the original date of sale to the professional/commercial user.
- c) 90 days from the original date of sale when used for hire.
- d) A reduced warranty period of 90 days applies to those items which are subject to normal wear and tear (e.g. but not limited to wheels, tyres, cutter bars, cylinders, cutting blades, blade boss, belts, cables, nylon line & spool, collection bags, spark plugs).
- e) Engines are supplied with a separate warranty to the machine. The engine manufacturers warranty statement which will be supplied within the engine instruction manual. All enquiries and warranty repairs should be discussed with the engine manufacturer or approved warranty repair dealer.
- f) 90 days from the original date of purchase for Replacement Spare Parts (unless normal wear & tear component, which are covered for 30 days).
- g) All machines' must be serviced within the first 12 months from the original date of purchase to comply with the warranty, failure to do so will invalidate the 2nd year of the warranty.

Webb Electric Handheld, Webb Dynamic, Heritage & Legacy, Handy, Mowerland, Q-Garden

- a) 1 year from the original date of sale to the first domestic user.
- b) 90 days from the original date of sale to the professional/commercial user.
- c) 90 days from the original date of sale when used for hire.
- d) A reduced warranty period of 90 days applies to those items which are subject to normal wear and tear (e.g. but not limited to wheels, tyres, cutter bars, cylinders, cutting blades, blade boss, belts, cables, nylon line & spool, collection bags, spark plugs).
- e) Engines are supplied with a separate warranty to the machine. The engine manufacturers warranty statement which will be supplied within the engine instruction manual. All enquiries and warranty repairs should be discussed with the engine manufacturer or approved warranty repair dealer.
- f) 90 days from the original date of purchase for Replacement Spare Parts (unless normal wear & tear component, which are covered for 30 days).

All warranty repairs must be undertaken by an authorised service dealer. These dealers have been accredited by GJ Handy & Co Ltd and agree to only use genuine parts and follow our repair procedures.

Not covered by this warranty

- a) The warranty policy does not cover any depreciation or damages caused by ordinary wear, rusting or corrosion, lack of correct maintenance or operation, misuse, abuse, lack of transportation or accident.
- b) The warranty policy does not cover any costs necessary for the standard periodic maintenance services instructed by the operator's manual, or service parts replacement which would include oil, filters, tyres, belts, brake linings, fuses, blades, seals and other service parts unless it can be proven that the item has evidence of faulty manufacture.
- c) The warranty policy will not cover failure or damage caused as a result of parts or accessories being modified without the written approval of GJ Handy & Co Ltd.
- d) The warranty policy will not cover the unit if non-genuine parts have been fitted and as a result damage has occurred to the unit.
- e) The warranty policy is non-transferable and is only applicable to the original purchaser.

Disclaimer

- a) This warranty is only a remedy for defect of products. GJ Handy & Co Ltd will never warranty in terms of the merchantability or the fitness for a particular purpose.
- b) No person is authorised to make any warranties, representations or promises, expressed or implied, on behalf of GJ Handy & Co Ltd, or to modify the terms conditions or limitation of this warranty policy in any way.
- c) Neither GJ Handy & Co Ltd nor any company affiliated with GJ Handy & Co Ltd shall be liable in any event or manner whatsoever for incidental or consequential damages or injuries, including, but not limited to, loss of crops, loss of profit, out of pocket expenses or profits, rental of substitute equipment or other commercial losses.

General

- a) Most warrantable failures show up within the first few weeks of use. These failures are usually straightforward and warranty assessment is relatively easy.
- b) Failures relating to cutter decks and belts need careful investigation, as the cause may not always be straightforward. Look for damage to blades and pulleys especially when the cutter belt or blade boss have snapped or cracked as this could be due to impact damage.
- c) Customers should always refer to the operator/instruction manual when any disputed problem arises, you will find most areas covered within the manual.

**For spares or support of your handy product,
please contact us:**

Tel: 01793 333212

**Email: customerservice@handydistribution.co.uk
(Mon – Fri 8.00am to 5.30pm excl. Bank Holidays)**

To see our range of garden machinery & equipment visit:

www.thehandy.co.uk

Making gardening easier & affordable since 1938

Distributed by Handy Distribution, Murdock Road, Dorcan, Swindon, SN3 5HY