



# INSTRUCTION MANUAL

# TOWED DRAG MAT

Model No: THDM -- Product No: 193846001

ASSEMBLY REQUIRED

SAVE THESE INSTRUCTIONS

SPARES & SUPPORT: 01793 333212

Please read & understand this manual, paying attention to the safety instructions, before use. The manufacturer reserves the right to change the product specification and livery according to continued product improvements.

Images used are for illustration purposes only.

02/02/2017



# CONTENTS

**SPECIFICATION**

**IMPORTANT INFORMATION**

**GENERAL SAFETY INSTRUCTIONS**

**ASSEMBLY**

**OPERATION**

**MAINTENANCE & STORAGE**

**PARTS DIAGRAM & LIST**

**USER WARRANTY**

## **ASSEMBLY IS REQUIRED**

This product requires assembly before use. See the “Assembly” section for instructions.

Please check that all parts required for the assembly of this spreader are included. If for any reason you believe a part for the assembly is missing or damaged, please contact us.

**If you require any assistance with regards to the contents or operation of your machine, please contact us:**

**TEL: 01793 333212**

**(MON – FRI 8.00AM TO 5.30PM EXCL. BANK HOLIDAYS)**

**EMAIL: [customerservice@handydistribution.co.uk](mailto:customerservice@handydistribution.co.uk)**

## **SPECIFICATION**

The manufacturer reserves the right to change the product specification and livery according to continued product improvements.

|                       |                   |
|-----------------------|-------------------|
| <b>Model</b>          | <b>THDM</b>       |
| <b>Product Number</b> | <b>193846001</b>  |
| Matt Dimensions (mm)  | (L)1525 x (W)1220 |
| Weight                | 18kg              |

# IMPORTANT INFORMATION

## INTENDED USE

The device is intended for to level or smooth dirt or gravel.

This product is not intended for commercial use.



Generally acknowledged accident prevention regulations and enclosed safety instructions must be observed.

Only perform work described in these instructions for use. Any other use is incorrect.

The manufacturer will not assume responsibility for damage resulting from such use.

## GENERAL SAFETY INSTRUCTIONS

It is important that you read and understand the owner’s manual and labels affixed to the machine. Learn its application and limitations as well as the specific potential hazards. Retain these instructions for future reference. The operator is responsible for following the warnings & instructions in this manual and on the product.

|   |   |  |  |
|---|---|--|--|
|  <p><b>WARNING</b><br/>Read &amp; understand operators manual before using this machine. Failure to follow operating instructions could result in death or serious injury.</p> | <p>Read &amp; understand operator’s manual before using the machine. Failure to follow instructions could result in death or serious injury.</p>  |  | <p>Risk of Slicing.<br/>Keep hands out of the way of all moving parts.</p> |
|   | <p>Use safety equipment. Always wear eye protection. Safety equipment such as a dust mask, non-skid safety shoes, hard hat, and heavy duty work gloves used for appropriate conditions will reduce personal injuries.</p> |  |  |



Safety alert symbol. Used to alert you to potential personal injury hazards. Obey all safety messages that follow this symbol to avoid possible injury.



### DANGER

Indicates an imminently hazardous situation which, if not avoided, will result in serious injury.



### WARNING

Indicates a potentially hazardous situation which, if not avoided, could result in serious injury



### CAUTION

Indicates a potentially hazardous situation which, if not avoided, may result in minor or moderate injury.

### CAUTION

Used without the safety alert symbol indicates a potentially hazardous situation which, if not avoided, may result in property damage.

### **STAY ALERT**

Do not operate the machine while under the influence of drugs, alcohol, or any medication that could affect your ability to use it properly. Do not use this machine when you are tired or distracted from the job at hand. Be aware of what you are doing at all times. Use common sense.

### **AVOID DANGEROUS CONDITIONS**

Make sure there is adequate surrounding workspace. Cluttered areas invite injuries. Keep your work area clean with sufficient light. Keep the area around the machine clear of obstructions, grease, oil, rubbish and other debris which could cause persons to fall onto moving parts.

### **INSPECT YOUR MACHINE**

Check all bolts, nuts, and screws for tightness before each use, especially those securing guards and drive mechanisms. Vibration during use, may cause these to loosen.

Form a habit of checking to see that all other tools/equipment are removed from the working area before using.

Replace damaged, missing or failed parts before using it.

Warning labels carry important information. Replace any missing or damaged warning labels.

### **DRESS PROPERLY**

Do not wear loose clothing, gloves, scarfs, neckties or jewellery (rings, wrist watches), which can be caught in moving parts. Protective electrically non-conductive gloves and non-skid heavy duty footwear are highly recommended when working. Wear protective hair covering to contain long hair, preventing it from getting caught in machinery.

### **KEEP BYSTANDERS AND CHILDREN AWAY**

Keep unauthorised persons away from the machine. If approached, stop the machine immediately.

Do not allow children to handle or climb on the machine.

### **DO NOT OVERREACH**

Keep proper footing and balance at all times when using the machine. Never stand on the machine. Serious injury could occur if the machine is tipped or if the moving parts are unintentionally contacted. Do not store anything above or near the machine, where anyone might stand on the machine to reach them.

### **AVOID INJURY FROM UNEXPECTED ACCIDENT**

Keep hands & feet out of the way of all moving parts. Do not place any part of your body or any tool e.g. in the machine during operation.

### **DO NOT FORCE TOOL**

Always work within the rated capacity. Do not use the machine for a purpose for which it was not intended.

### **NEVER LEAVE MACHINE UNATTENDED**

Do not leave the machine unattended until it has come to a complete stop.

### **MAINTAIN YOUR PRODUCT WITH CARE**

Clean the machine immediately after use. Keep the machine clean to ensure it operates to its full & safest performance. When maintaining this machine, only the manufacturer's original replacement parts should be used. The use of non-original manufacturer parts may invalidate your warranty.

### **PROTECT THE ENVIRONMENT**

Take left over materials to an authorised collection point or follow the stipulations in the country where the mixer is used. Do not discharge into drains, soil or water.

### **STORE IDLE EQUIPMENT**

When not in use, the machine should be stored in a dry location. Keep the machine away from children and others not qualified to use it.

## ASSEMBLY

- Lay the harrow onto the ground and stretch out flat.
- The rounded heads of the carriage bolts (7) should be facing upwards.
- Check all the fasteners to ensure that they are tight.
- Fasten the quick link (1) onto the chain (2) at any desired position to pull the harrow straight or at angles.
- Additional weight may be added to the unit by placing 8" concrete blocks along the front section as shown in the diagram below. **NOTE - Hold down straps may be necessary to secure blocks into place.**
- After you have located the quick link in the desired position, hook the link into the hole of your hitch plate.

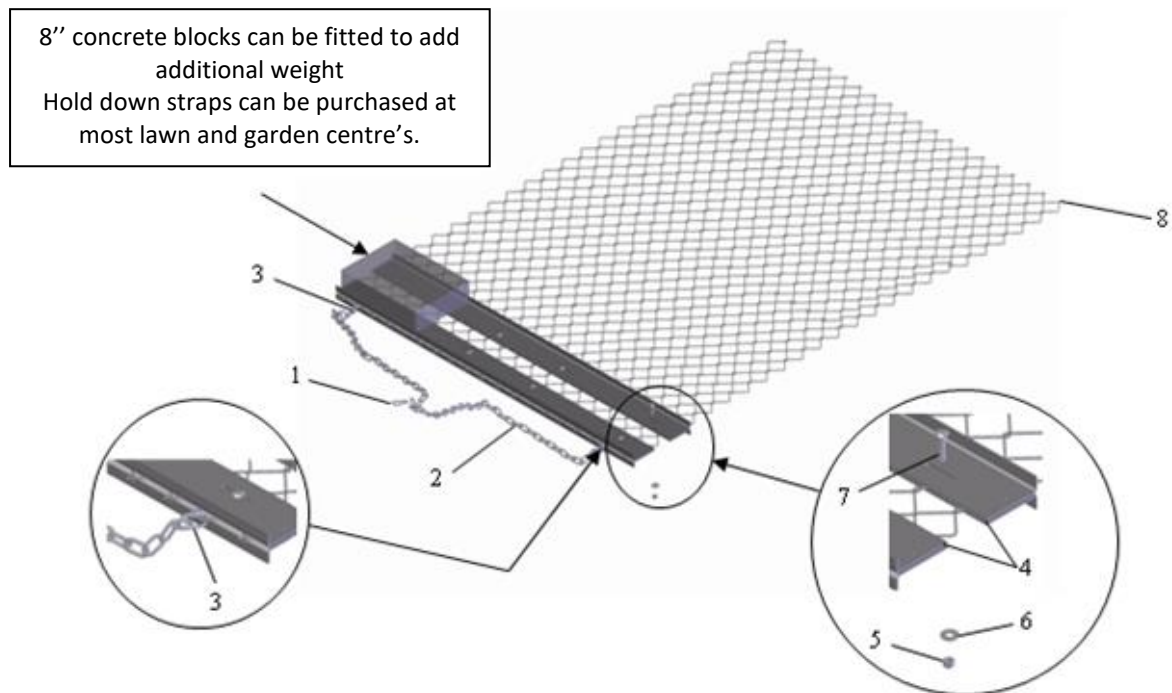

# OPERATION



## WARNING

Before using the Drag Mat, review the below instructions & safety information within the manual. Failure to follow these instructions may result in property damage or injury to the operator or bystanders.

- **ALWAYS** inspect the Drag Mat prior to each use for faulty or damaged components.
- **IMMEDIATELY** replace or repair damaged or worn components before using.
- **CHECK & TIGHTEN** all hardware before each use.
- **ALWAYS** secure and lock the Drag Mat to the vehicle hitch before operating.
- **ONLY** use approved vehicles when towing the Drag Mat (Lawn/Garden Tractors and ATVs)
- **ONLY** use the Drag Mat for its intended purpose.
- **DO NOT** use the Drag Mat on public roads.
- **NEVER** exceed 10mph when towing the Drag Mat.
- **BE CAREFUL** when operating on steep gradients (hills) the Lawn/Garden Tractors and ATVs may tip over.
- **ALWAYS** operate at a reduced speed in rough terrain, along creeks, ditches and on hillsides.
- **DO NOT** operate close to creeks, ditches and public roads.
- **DO NOT** make sharp turns as this may cause the Lawn/Garden Tractor or ATV tyres to rub against the Drag Mat.
- **ALWAYS** slow down before turning.
- **NEVER** reverse when using the Drag Mat.
- **DO NOT** allow anyone to sit or stand on the Drag Mat.
- **DO NOT** allow children to play on, stand upon or climb in the Drag Mat.
- **ALWAYS** keep your hands and feet clear from moving parts while operating the equipment.
- **ALWAYS** keep the work area clean and clear when operating.
- **ALWAYS** wear safety gear, eye protection, gloves and work boots when operating the Drag Mat.



## CAUTION

To avoid possible injury, be sure that no bystander is near the Drag Mat before releasing the latch.



## CAUTION

Vehicle braking & stability may be affected by the Drag Mat. Be aware of changing conditions on slopes.

# MAINTENANCE & STORAGE



## WARNING

**Improper maintenance & storage of the Drag Mat may void your warranty.**

### MAINTENANCE

- After each use clean any material out of the Drag Mat.
- Rinse/dry the Drag Mat after each use.
- Periodically check all nuts & bolts for tightness.

### **IMPORTANT:**

Only use the manufacturer's original replacement parts. Non-original replacement parts will invalidate your warranty and may result in a safety hazard or poor operation. Parts are available by calling 01793 333212.

### STORAGE

- Never allow material to remain in the Drag Mat for extended periods of time.
- For years of trouble free service, make sure the Drag Mat is clean and dry before storing.
- Store indoors or in a protected area during severe weather and winter months.
- For convenience, roll the Drag Mat to reduce amount of storage space used.
- Annually clean and lightly lubricate parts with Maintenance spray.



# PARTS DIAGRAM & LIST

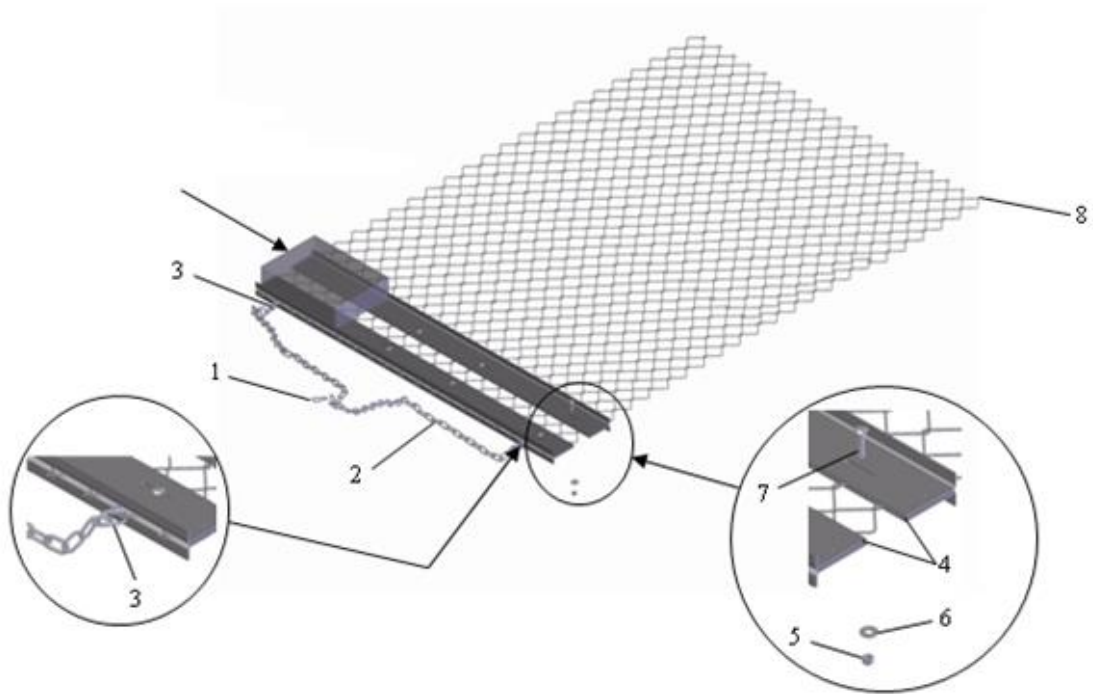

| Ref | Part No. | Description                | Qty |
|-----|----------|----------------------------|-----|
| 1   | TH182-1  | QUICK LINK                 | 1   |
| 2   | TH182-2  | 6 ' CHAIN                  | 1   |
| 3   | TH182-3  | 3/16" CHAIN CONNECTOR      | 2   |
| 4   | TH182-4  | HARROW PLATE               | 4   |
| 5   | TH182-5  | M6 NYLOCK NUT              | 8   |
| 6   | TH182-6  | FLAT WASHER                | 8   |
| 7   | TH182-7  | M6 X 35 CARRIAGE BOLT      | 8   |
| 8   | TH182-8  | 4' X 5' X 9-GA. LINK FENCE | 1   |

# GJ HANDY & CO LTD USER WARRANTY POLICY

## **Users Statement of Warranty**

Each new machine is warranted against defective material or assembly of material under normal usage. The warranty applies to the original purchaser and covers faulty parts and the labour involved in replacing and repairing those parts, which are of original manufacture.

## **Period of Warranty**

### **All Webb & Webb Pro machines plus Sanli engines.**

- a) 2 years from the original date of sale to the first domestic user.
- b) 90 days from the original date of sale to the professional/commercial user.
- c) 90 days from the original date of sale when used for hire.
- d) A reduced warranty period of 90 days applies to those items which are subject to normal wear and tear (e.g. but not limited to wheels, tyres, cutter bars, cylinders, bottom blades, belts, cables, grass bags, spark plugs).
- e) Engines as per the manufacturer's warranty statement which will be supplied with the machine.
- f) 90 days from the original date of purchase for Replacement Spare Parts (unless normal wear & tear component, which are covered for 30 days).
- g) All machines' must be serviced within the first 12 months from the original date of purchase to comply with the warranty, failure to do so will invalidate the 2nd year of the warranty.

### **All Handy, Mowerland and Q-Garden products.**

- a) 1 year from the original date of sale to the first domestic user.
- b) 90 days from the original date of sale to the professional/commercial user.
- c) 90 days from the original date of sale when used for hire.
- d) A reduced warranty period of 90 days applies to those items which are subject to normal wear and tear (e.g. but not limited to wheels, tyres, cutter bars, cylinders, bottom blades, belts, cables, collection bags, spark plugs).
- e) Engines as per the manufacturer's warranty statement which will be supplied with the machine.
- f) 90 days from the original date of purchase for Replacement Spare Parts (unless normal wear & tear component, which are covered for 30 days).

All warranty repairs must be undertaken by an authorised service dealer. These dealers have been accredited by GJ Handy & Co Ltd and agree to only use genuine parts and follow our repair procedures.

*VERSION 4 (10-16)*

02/02/2017

# GJ HANDY & CO LTD USER WARRANTY POLICY

## **Not covered by this warranty**

- a) The warranty policy does not cover any depreciation or damages caused by ordinary wear, rusting or corrosion, lack of correct maintenance or operation, misuse, abuse, lack of transportation or accident.
- b) The warranty policy does not cover any costs necessary for the standard periodic maintenance services instructed by the operator's manual, or service parts replacement which would include oil, filters, tyres, belts, brake linings, fuses, blades, seals and other service parts unless it can be proven that the item has evidence of faulty manufacture.
- c) The warranty policy will not cover failure or damage caused as a result of parts or accessories being modified without the written approval of GJ Handy & Co Ltd.
- d) The warranty policy will not cover the unit if non-genuine parts have been fitted and as a result damage has occurred to the unit.
- e) The warranty policy is non-transferable and is only applicable to the original purchaser.

## **Disclaimer**

- a) This warranty is only a remedy for defect of products. GJ Handy & Co Ltd will never warranty in terms of the merchantability or the fitness for a particular purpose.
- b) No person is authorised to make any warranties, representations or promises, expressed or implied, on behalf of GJ Handy & Co Ltd, or to modify the terms conditions or limitation of this warranty policy in any way.
- c) Neither GJ Handy & Co Ltd nor any company affiliated with GJ Handy & Co Ltd shall be liable in any event or manner whatsoever for incidental or consequential damages or injuries, including, but not limited to, loss of crops, loss of profit, out of pocket expenses or profits, rental of substitute equipment or other commercial losses.

## **General**

- a) Most warrantable failures show up within the first few weeks of use. These failures are usually straightforward and warranty assessment is relatively easy.
- b) Failures relating to cutter decks and belts need careful investigation, as the cause may not always be straightforward. Look for damage to blades and pulleys especially when the cutter belt or blade boss have snapped or cracked as this could be due to impact damage.
- c) Customers should always refer to the operator/instruction manual when any disputed problem arises, you will find most areas covered within the manual.

For spares or support of your handy product,  
please contact us:

Tel: 01793 333212

(Mon – Fri 8.00am to 5.30pm excl. Bank Holidays)

Email: [customerservice@handydistribution.co.uk](mailto:customerservice@handydistribution.co.uk)

**To see our range of garden machinery & equipment visit:**

**[www.thehandy.co.uk](http://www.thehandy.co.uk)**

**Making gardening easier & affordable since 1938**

Distributed by Handy Distribution, Murdock Road, Dorcan, Swindon, SN3 5HY