

The Strom E-Boiler

INSTALLATION GUIDE

4TH ISSUE
FOR REV 2 BOILERS ONLY

REMEMBER TO REGISTER
WWW.STROMLTD.COM/GUARANTEE

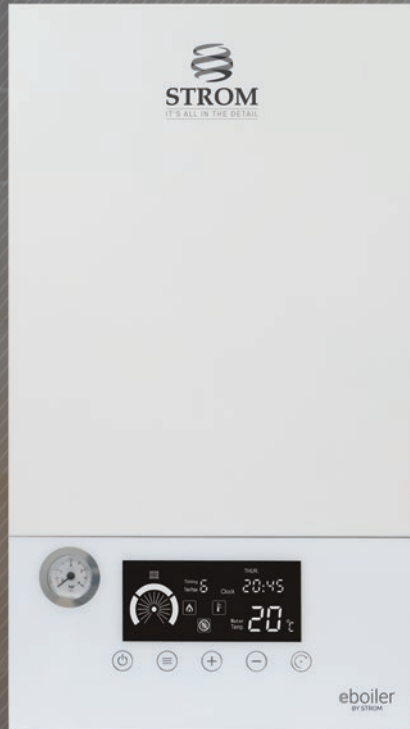

THE FUTURE OF HEATING
IT'S ALL IN THE DETAILS...

www.stromltd.com
STROM LIMITED 2021



STROM
IT'S ALL IN THE DETAIL

Electric Boilers

INTRODUCTION

Please read the whole manual before attempting installation and follow these installation instructions carefully following the correct operating instructions to ensure long life of this Strom Electric Boiler. These instructions must be conserved and given to any new user.

All boilers come with a full **2-year warranty** from the date of registration (registration must occur within the first 45 days of purchase) unless purchased with a promotional warranty. The warranty relates to any manufacturing defects and covers the replacement of any faulty parts and labour costs. The warranty will not cover damage to the boiler through poor installation, and any consequent water damage or leaks into the boiler - All plumbing must be checked before the boiler is left with the end user for normal operation and water tightness. The warranty will not cover charges that have not been organised by Strom Ltd.

This appliance is not intended for use by anyone (including children) with reduced physical, sensorial or mental capacities, or lack of experience with the appliance, unless they have been given supervision or instruction by a competent person responsible for their safety.

BY FITTING THIS BOILER YOU AGREE:

- YOU HAVE CARRIED OUT ALL HEAT LOSS CALCULATIONS ON THE PROPERTY AND ARE SURE THAT THIS BOILER IS SUITABLE FOR THE APPLICATION.
- YOU HAVE CARRIED OUT A VOLTAGE AND LOAD TEST TO DETERMINE THE CORRECT SIZED BREAKER IS USED.
- YOU HAVE CHECKED IN THE CASE OF THE COMBINATION BOILER THAT THE HOT WATER FLOW RATE IS SUFFICIENT FOR THE APPLICATION
- THAT THE BOILER IS FITTED IN A MANOR AND LOCATION WHERE IT CANNOT BE ACCESSED BY UNAUTHORISED/UNQUALIFIED PERSONS.
- TO BE BOUND TO THE TERMS AND CONDITIONS ON THE LAST PAGE OF THIS MANUAL.
 - THE BOILER HAS BEEN RECEIVED IN GOOD CONDITION.
 - AN ELECTRICAL CERTIFICATE WILL BE PROVIDED IMMEDIATELY AFTER A LIVE CONNECTION HAS BEEN MADE TO THE BOILER, THIS IS A CONDITION OF THE WARRANTY. PART P REGULATIONS CLEARLY STATE THAT WHEN ANY NEW CIRCUIT OR ALTERATION TO AN EXISTING CIRCUIT HAS OCCURED A CERTIFICATE MUST BE PROVIDED.
- A PART P CERTIFICATE WILL BE ISSUED IN ACCORDANCE WITH BUILDING REGULATIONS UK. BOILERS REGARDLESS OF FUEL TYPE ARE CLASSED AS NOTIFIABLE WORKS.

This electric boiler must be fitted in accordance with the following: -

- The local building regulations
- UK building regulations

BS EN 12828

Heating systems in buildings: Design for water-based heating systems.

BS EN 12831

Heating systems in buildings: Method for calculation of the design heat load

BS EN 14336

Heating systems in buildings: Installation and commissioning of water-based heating systems

BS7671

Requirements for electrical installations. IEE Wiring Regulations. Seventeenth edition

BS EN 7593

Code of practice for treatment of water in heating systems

1. Load Check

- A load check should be taken into consideration when installing high output boilers

2. Central heating design

- Detailed recommendations are provided in BS EN 12828 and BS EN 6700

3. Location

- The boiler can be installed in almost any location, but consideration should be given to the potential of frost or damp conditions, and to the future maintenance of the equipment. Clearance should be allocated for the removal of the front panel if necessary and for air flow into the boiler. The boiler must be installed in an upright position, failure to do so will invalidate the warranty. The wall where the boiler is being sited should be strong enough to support the weight of the boiler when full.

Electric Boilers

STAYING COMPLIANT

When installing an electric boiler it is important to pay attention to all national and local laws and by-laws to make sure that you are safe and your installation is compliant.

Installations of electric boilers should only be completed by qualified electricians who are members of a competent persons scheme. It is a requirement in law and of the schemes that an electrical installation certificate is provided for electric boiler installs as this will class as a “a new circuit or significant alteration of an existing circuit”.

Building regulations also stipulate that boiler installations regardless of fuel type are notifiable by law. The easiest way to comply is to use a competent person who in addition to the electrical installation certificate will need to legally provide you with a Part P certificate.

Below is an extract from the Department For Communities & Local Government showing what is required:

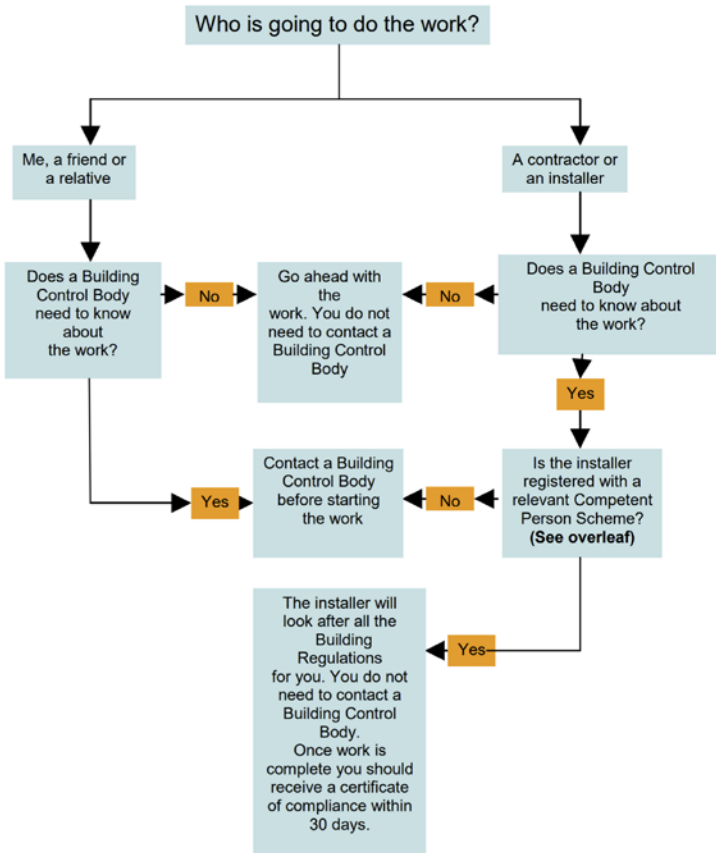

Remember even as the homeowner it is your job to ensure that your property complies with this law. Failure to do so may result in legal fines being levied, insurance policies being cancelled, and possible prison sentences. Selling your house may also prove difficult without the correct paperwork in place.

For more information about the requirements for electrical works being carried out look at a competent persons scheme website like:

www.NICEIC.com

Or check out the building regulations approval site at:

<https://www.gov.uk/building-regulations-approval>

Electric Boilers

BOILER SPECIFICATION

COMBINATION ALL ELECTRIC BOILER...

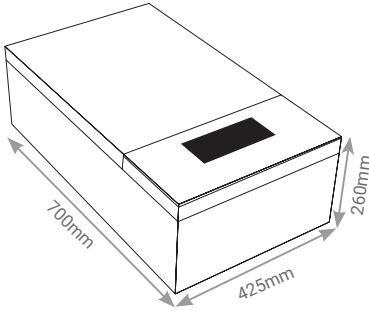

	SINGLE PHASE			THREE PHASE		
	7kW	11kW	14.4kW	18kW	21kW	24kW
Voltage	230V	230V	230V	400V	400V	400V
Amps	32A	55A	62A	27A	32A	36A
Recommended Breaker	40A	63A	63A	32A	40A	40A
Recommended Cable Size	4mm ²	10mm ²	10mm ²	3x4mm ²	3x6mm ²	3x6mm ²
Max. Heating Pressure	1.5 Bar					
Min. Heating Pressure	0.5 Bar					
Max. DHW Pressure	6.0 Bar					
DHW Flow Rate (ltrs/min)*	4	6	7	9	10	12
Heating Connection Size	3/4" Male (We Recommend Flexi Hoses, Not Irons)					
DHW Connection Size	1/2" Male (We Recommend Flexi Hoses, Not Irons)					
PRV Connection Size	1/2" Female					

*Recommended Flow Rate To Offer 30 Degree Temperature Rise Of Incoming Cold Mains Supply

SYSTEM ALL ELECTRIC BOILER...

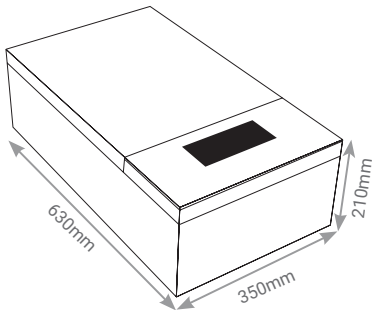

	SINGLE PHASE			THREE PHASE		
	7kW	11kW	14.4kW	18kW	21kW	24kW
Voltage	230V	230V	230V	400V	400V	400V
Amps	32A	55A	62A	27A	32A	36A
Recommended Breaker	40A	63A	63A	32A	40A	40A
Recommended Cable Size	4mm ²	10mm ²	10mm ²	3x4mm ²	3x6mm ²	3x6mm ²
Max. Heating Pressure	1.5 Bar					
Min. Heating Pressure	0.5 Bar					
Max. Flow Temp	80°C					
Min. Flow Temp	20°C					
Heating Connection Size	3/4" Male (We Recommend Flexi Hoses, Not Irons)					
PRV Connection Size	1/2" Female					

WHATS IN THE BOX?

1. BOILER
2. INTEGRATED WALL MOUNTING BRACKET
3. WALL MOUNTING GUIDE
4. 3 x EXPANDING WALL BOLTS

Electric Boilers

INSTALLATION SCHEDULE

Please ensure that all steps of the installation schedule are carried out in this order, and only this order. Failing to carry out the installation in this order may result in damage to the boiler and incorrect function of the system.

PRIOR TO INSTALLATION

1. HEAT LOSS CALCULATION.

Correctly calculate the correct size unit for the properties heating demand. We regret to inform you that after installation there is no way to boost the output of the unit so it is important you get the correct unit for the property. Strom are unable to assist with these calculations.

2. HOT WATER CALCULATION.

COMBI BOILER ONLY

For combination units ensure that the boiler has a sufficient heat output to provide the correct temperature & flow of water required for the application. If you need help calculating this please contact Strom.

3. VOLTAGE & LOAD CALCULATION.

Typically the UK single phase supply is 230V, all our technical data is based on this, however you should do a measurement and correctly determine the correct input voltage, this will determine the size of breaker and cable size required. All our breaker and cable size recommendations are only that, and should be checked against your requirements.

4. MAINS WATER PRESSURE.

COMBI BOILER ONLY

The maximum rated pressure of the units is 6bar, where water pressure is approaching this limit, or where dynamic pressure varies and may exceed this a pressure reducing set on the mains supply should be installed.

All of these considerations must be made prior to at least installation but preferably before purchase is made. Regretably once the box to the boiler has been opened we are unable to accept returns of the product unless the product is faulty or does not operate as advertised by Strom.

IMPORTANT

It is important that once you start installing the boiler you do not leave it unattended with power connected or water in the circuits unless the whole installation and all steps have been completed. If you intend to leave the boiler unattended without completing the installation you should ensure that no leaks are present or possible, and that the electric have been isolated.

INSTALLATION

- | | |
|---------------------------------|-------------|
| 1. COMPLETE SYSTEM PIPING. | SEE PAGE 12 |
| 2. WALL MOUNT THE BOILER. | SEE PAGE 23 |
| 3. CONNECT, FILL & FLUSH BOILER | SEE PAGE 25 |
| 4. CHECK ALL WATER CONNECTIONS | SEE PAGE 28 |
| 5. MAKE ELECTRICAL CONNECTION | SEE PAGE 29 |
| 6. WIRE AN EXTERNAL THERMOSTAT | SEE PAGE 30 |
| 7. CHECK ELECTRIC CONNECTIONS | SEE PAGE 31 |
| 8. POWER ON THE BOILER | SEE PAGE 32 |
| 9. SET BOILER PARAMETERS | SEE PAGE 33 |
| 10. SET PUMP SPEED & PURGE AIR | SEE PAGE 34 |
| 11. SET DHW FLOW & TEMPERATURE | SEE PAGE 35 |

POST INSTALLATION

- | | |
|-----------------------------|---|
| 1. PROGRAM THERMOSTAT. | REFER TO MANUFACTURERS MANUAL |
| 2. TEST HEATING & HOT WATER | SEE PAGE 36 |
| 3. COMPLETE CHECK LIST | SEE PAGE 37 |
| 4. ASK OWNER TO REGISTER | REFER TO www.stromltd.com/guarantee |

Electric Boilers

HEAT ONLY SCHEMATIC

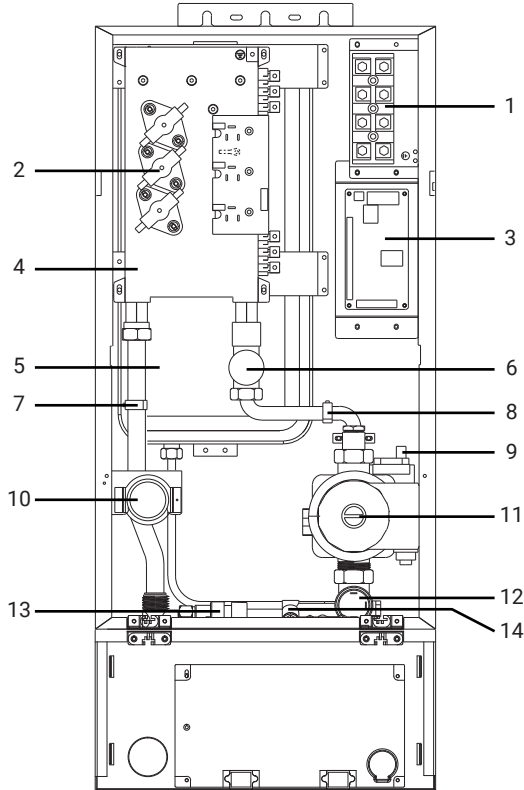

- | | | | |
|----|--|-----|---|
| 1. | Power Connection Terminals | 8. | Temperature Sensor For Heat Return |
| 2. | Thermal Cut-Outs | 9. | Automatic Air Vent (access behind pump) |
| 3. | Control PCB (thermostat connections) | 10. | Pressure Gauge |
| 4. | Heating System Patented Heat Exchanger | 11. | Pump |
| 5. | Heating Expansion Vessel | 12. | Pressure Sensor (linked to gauge) |
| 6. | Dedicated Heating Flow Sensor | 13. | Pressure & Expansion Relief Valve |
| 7. | Temperature Sensor For Heat Flow | 14. | Heating System Filling Valve |

Electric Boilers

COMBI SCHEMATIC

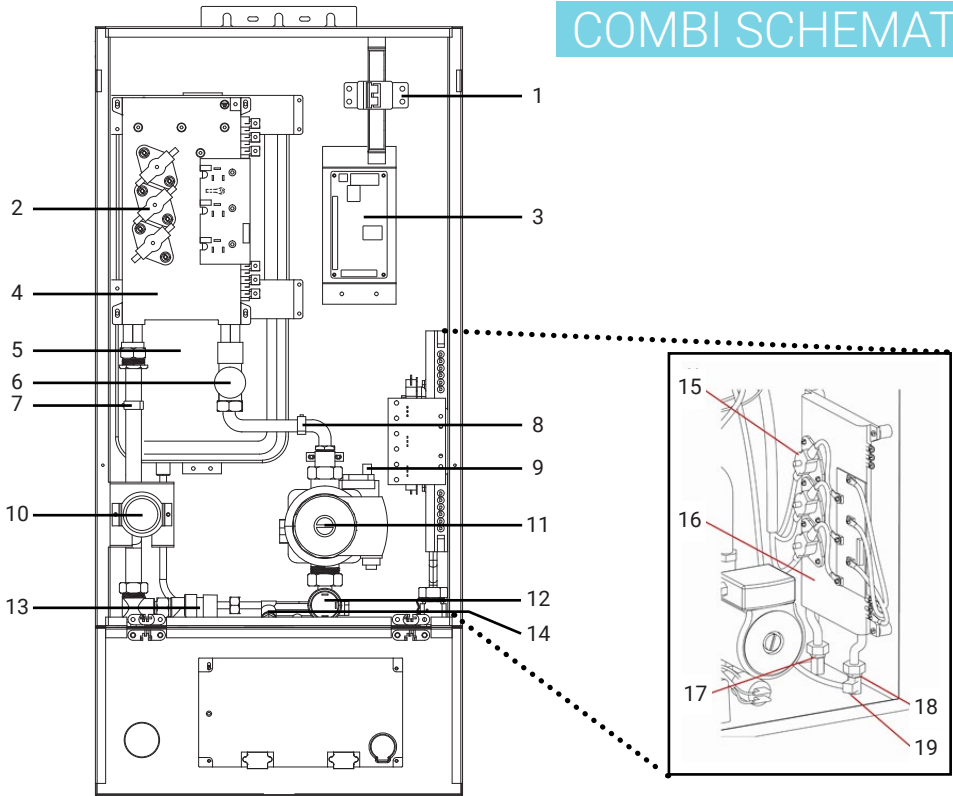

- | | | | |
|-----|---|-----|---|
| 1. | Power Connection Terminals | 11. | Pump |
| 2. | Thermal Cut-Outs | 12. | Pressure Sensor (linked to gauge) |
| 3. | Control PCB (thermostat connections) | 13. | Pressure & Expansion Relief Valve |
| 4. | Heating System Patented Heat Exchanger | 14. | Heating System Filling Valve |
| 5. | Heating Expansion Vessel | 15. | Thermal Cut-Outs |
| 6. | Dedicated Heating Flow Sensor | 16. | Hot Water Patented Heat Exchanger |
| 7. | Temperature Sensor For Heat Flow | 17. | Temperature Sensor For Hot Water Outlet |
| 8. | Temperature Sensor For Heat Return | 18. | Temperature Sensor For Cold Water Inlet |
| 9. | Automatic Air Vent (access behind pump) | 19. | Flow Sensor For Domestic Hot Water |
| 10. | Pressure Gauge | | |

Electric Boilers

SCREEN DIAGRAM

POWER INDICATOR

Shows if the boiler is receiving power & powered on

BOILER ACTIVITY

Shows if the boiler is heating water or central heating.

(Combi Only)

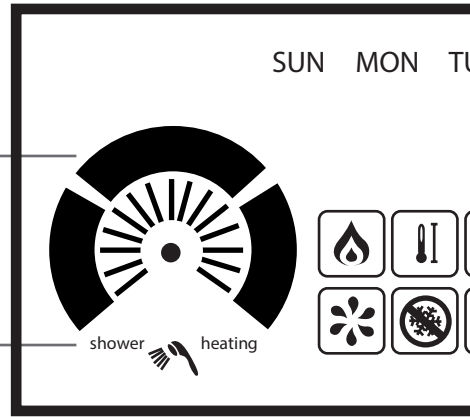

POWER BUTTON

Turns the boiler On or Off.



MENU BUTTON

Used by the installer to enter configuration mode.



INCREASE

Increases va
temper



IGNITION

The boiler is currently heating up either for heating or hot water.



RETURN TEMPERATURE

The return temperature is too high.



RETURN TEMPERATURE

The return temperature has reached the temperature differential set by the installer.

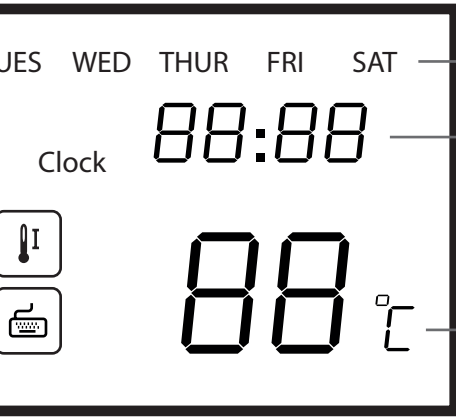

DATE INDICATOR

CLOCK

Shows the current time as set during boiler setup.

TEMPERATURE

Shows the current temperature of the heating or hot water.



INCREASE VALUE

Increases value such as temperature.



DECREASE VALUE

Decreases value such as temperature.



ADMIN MENU

Used only under instruction by Strom.



PUMP RUNNING

While lit solid the pump is running and is performing as expected.



FROST PROTECT

The boiler is too cold and is entering a defrost cycle in attempt to prevent damage to the boiler.



THERMOSTAT STATUS

While lit solid there is an external thermostat fitted and there is a demand for heat, while flashing there is either no thermostat fitted or no demand for heat.

Electric Boilers

SYSTEM PIPING

The boiler must be installed by a competent and certified plumber or heating engineer and systems should be designed to meet the current building regulations in force at the time of installation.

Strom Limited are not responsible for faulty installations which are performed by unqualified tradespeople.

DESIGN NOTES:

ISOLATION VALVES:

For ease of removal from the system, it is recommended that full bore isolation valves are fitted on the flow and return pipework from the boiler. Do not use standard ball valves, as this can restrict the flow in and out of the boiler and result in detrimental performance.

AUTOMATIC AIRVENTS

An automatic air vent is already built into the boiler. However, if the boiler is to be used in tandem with a hot water cylinder, an additional air vent should be fitted in the vicinity of the cylinder coil. An airvent should always be considered at the highest point in a system to aid in purging the system of any air.

AUTOMATIC BYPASS VALVE

An automatic bypass valve is integral to any system and **MUST** be installed as part of this installation. The ABV should be fitted to begin opening as the first valve, radiator, or actuator shuts in the system, this stops excess pressure from building in the system on the flow side. Failure to fit and set the ABV can result in poor performance and premature boiler failure.

WATER CONNECTIONS

For filling the heating system, reference should be made to BS EN 14336. There must be no connection between the central heating systems and the main water supply, and all local water bylaws must be observed. Any connection made between the mains water and heating system must be disconnected after use.

WATER PURGES

Install purges in the radiators and any high points in the heating system to aid in removing air.

DRAIN POINT

A drain point should be fitted at the lowest point of the heating system. It is not acceptable to drain the boiler through a safety valve as debris can prevent the correct operation of the valve.

HEATING EXPANSION VESSEL





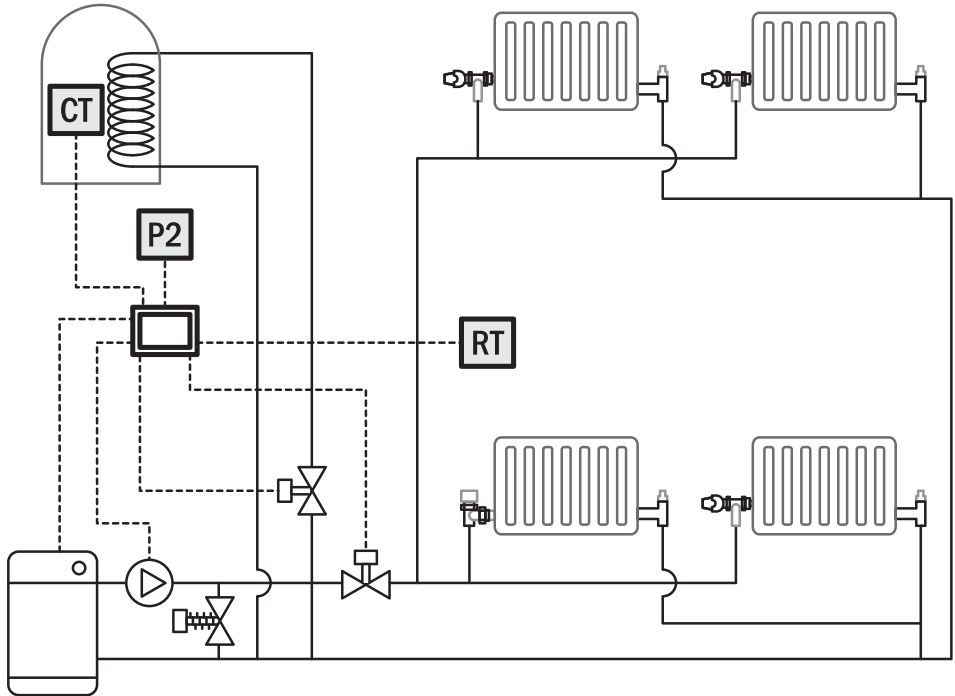

An expansion vessel is fitted internally within the boiler to provide room for thermal expansion of water under regular operating conditions. However, if the system contains significant volumes of water, an additional heating expansion vessel should be fitted externally.

PART L COMPLIANT LAYOUTS

HEAT ONLY BOILER

PROGRAMMER, ROOM THERMOSTAT & TRV'S - 2 PORT VALVE CONTROL (<150m²)



- 
BOILER
- 
2 PORT
- 
3 PORT
- 
ABV
- 
WHEEL
HEAD
VALVE
- 
LOCK
SHIELD
VALVE
- 
THERMASTIC
RAD VALVE

- 
ROOM
STAT
- 
PROG
ROOM
STAT
- 
MULTI
CHAN
PROG
- 
TWO
CHAN
PROG
- 
ONE
CHAN
PROG
- 
CYL
STAT
- 
JUNCT.
BOX
- WIRING

DIAGRAMS PROVIDED AS GUIDANCE ONLY, FINAL DESIGN SHOULD BE DECIDED UPON BY A QUALIFIED PLUMBER INLINE WITH CURRENT PART L GUIDELINES.

Electric Boilers

PART L COMPLIANT LAYOUTS

HEAT ONLY BOILER

PROGRAMMER, ROOM THERMOSTAT & TRV'S - 3 PORT VALVE CONTROL (<150m²)

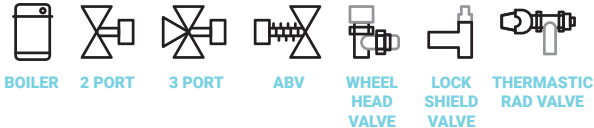
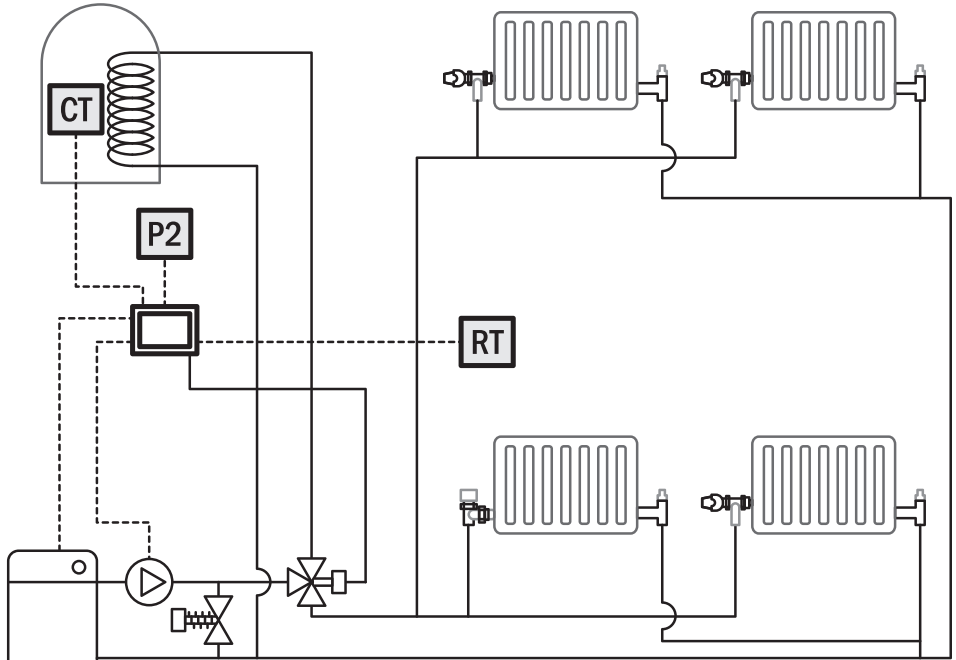





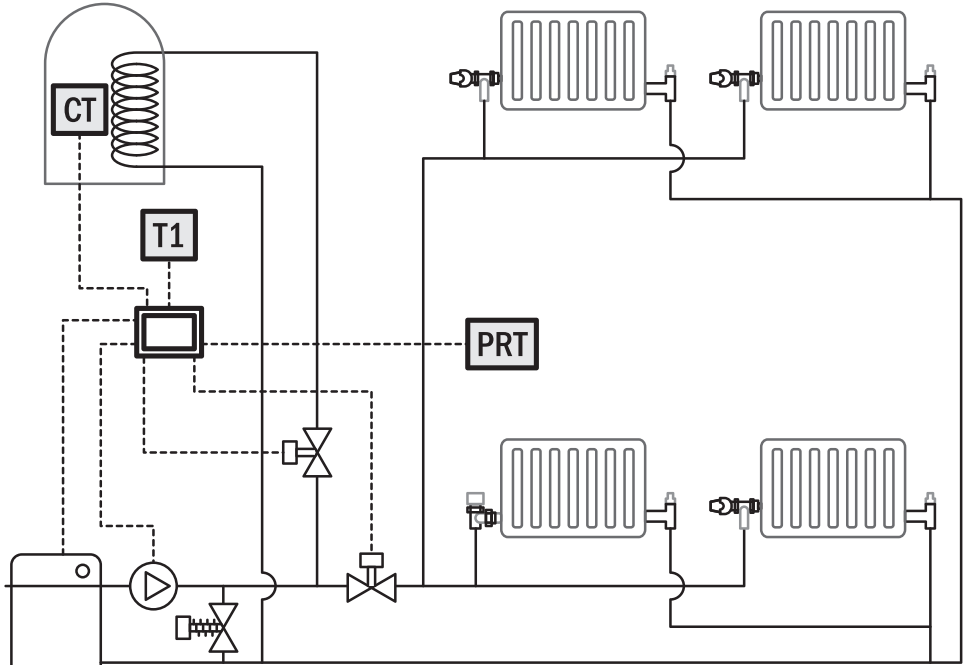

DIAGRAMS PROVIDED AS GUIDANCE ONLY, FINAL DESIGN SHOULD BE DECIDED UPON BY A QUALIFIED PLUMBER INLINE WITH CURRENT PART L GUIDELINES.

HEAT ONLY BOILER

PROGRAMABLE ROOM THERMOSTAT & TRV'S - 2 PORT VALVE CONTROL (<150m²)



- 
BOILER
- 
2 PORT
- 
3 PORT
- 
ABV
- 
WHEEL
HEAD
VALVE
- 
LOCK
SHIELD
VALVE
- 
THERMASTIC
RAD VALVE

- 
ROOM
STAT
- 
PROG
ROOM
STAT
- 
MULTI
CHAN
PROG
- 
TWO
CHAN
PROG
- 
ONE
CHAN
PROG
- 
CYL
STAT
- 
JUNCT.
BOX
- WIRING

DIAGRAMS PROVIDED AS GUIDANCE ONLY, FINAL DESIGN SHOULD BE DECIDED UPON BY A QUALIFIED PLUMBER INLINE WITH CURRENT PART L GUIDELINES.

Electric Boilers

PART L COMPLIANT LAYOUTS

HEAT ONLY BOILER

PROGRAMABLE ROOM THERMOSTAT & TRV'S - 3 PORT VALVE CONTROL (<150m²)

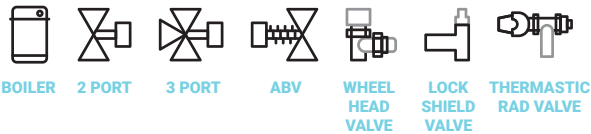
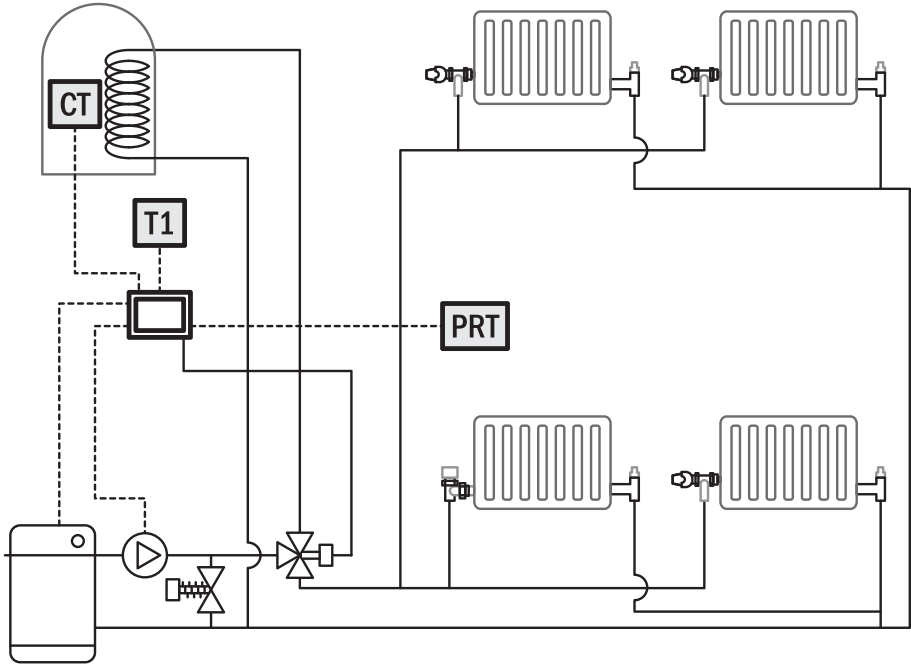

DIAGRAMS PROVIDED AS GUIDANCE ONLY, FINAL DESIGN SHOULD BE DECIDED UPON BY A QUALIFIED PLUMBER IN LINE WITH CURRENT PART L GUIDELINES.

COMBINATION BOILER

PROGRAMMER, ROOM THERMOSTAT & TRV'S - 2 PORT VALVE CONTROL (<150m²)

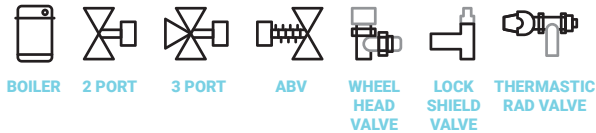
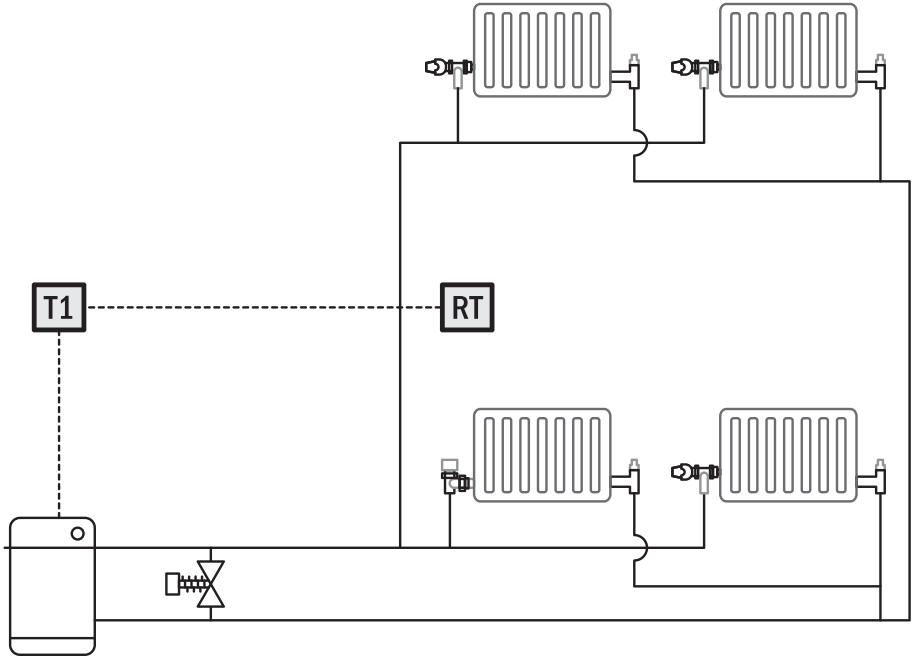

DIAGRAMS PROVIDED AS GUIDANCE ONLY, FINAL DESIGN SHOULD BE DECIDED UPON BY A QUALIFIED PLUMBER INLINE WITH CURRENT PART L GUIDELINES.

Electric Boilers

PART L COMPLIANT LAYOUTS

HEAT ONLY BOILER

PROGRAMABLE ROOM THERMOSTAT & TRV'S - 2 PORT VALVE CONTROL (<150m²)

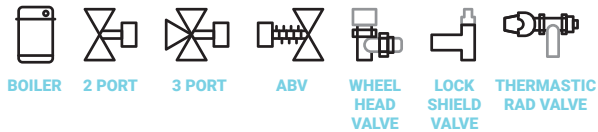
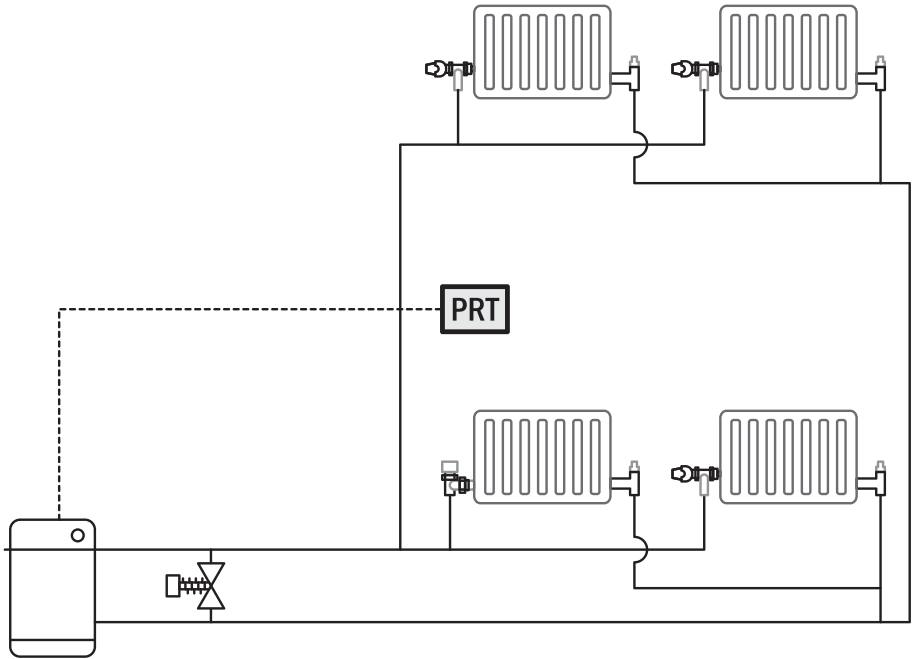





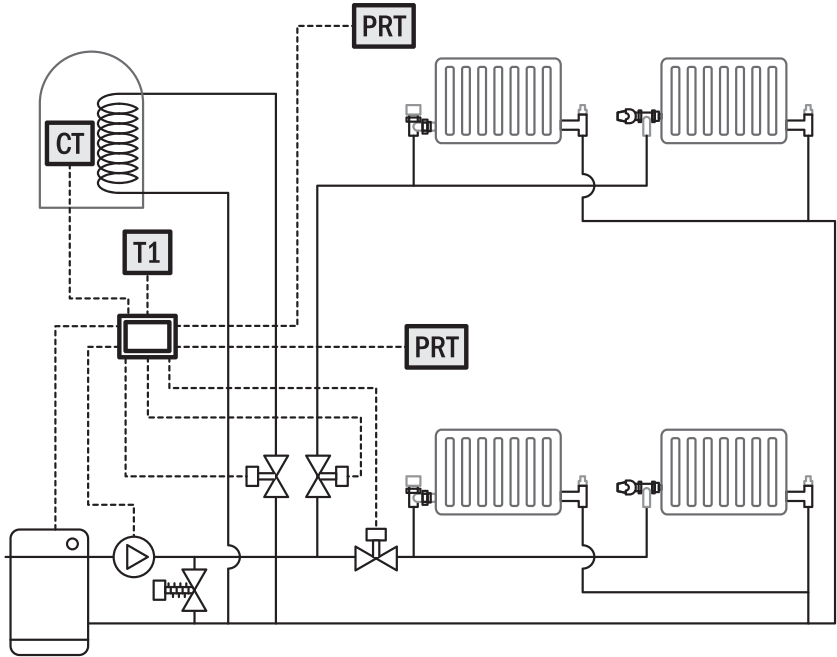

DIAGRAMS PROVIDED AS GUIDANCE ONLY, FINAL DESIGN SHOULD BE DECIDED UPON BY A QUALIFIED PLUMBER IN LINE WITH CURRENT PART L GUIDELINES.

HEAT ONLY BOILER

PROGRAMMABLE ROOM THERMOSTATS & TRV'S (150m²+)



- 
BOILER
- 
2 PORT
- 
3 PORT
- 
ABV
- 
WHEEL
HEAD
VALVE
- 
LOCK
SHIELD
VALVE
- 
THERMASTIC
RAD VALVE

- RT**
ROOM
STAT
- PRT**
PROG
ROOM
STAT
- P3+**
MULTI
CHAN
PROG
- P2**
TWO
CHAN
PROG
- T1**
ONE
CHAN
PROG
- CT**
CYL
STAT
- 
JUNCT.
BOX
- WIRING

DIAGRAMS PROVIDED AS GUIDANCE ONLY, FINAL DESIGN SHOULD BE DECIDED UPON BY A QUALIFIED PLUMBER INLINE WITH CURRENT PART L GUIDELINES.

Electric Boilers

PART L COMPLIANT LAYOUTS

HEAT ONLY BOILER

MULTI CHANNEL PROGRAMMER, ROOM THERMOSTATS & TRV'S (150m²+)

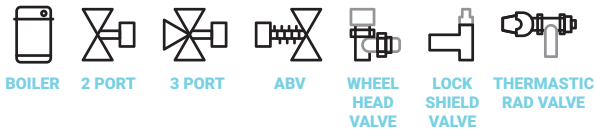
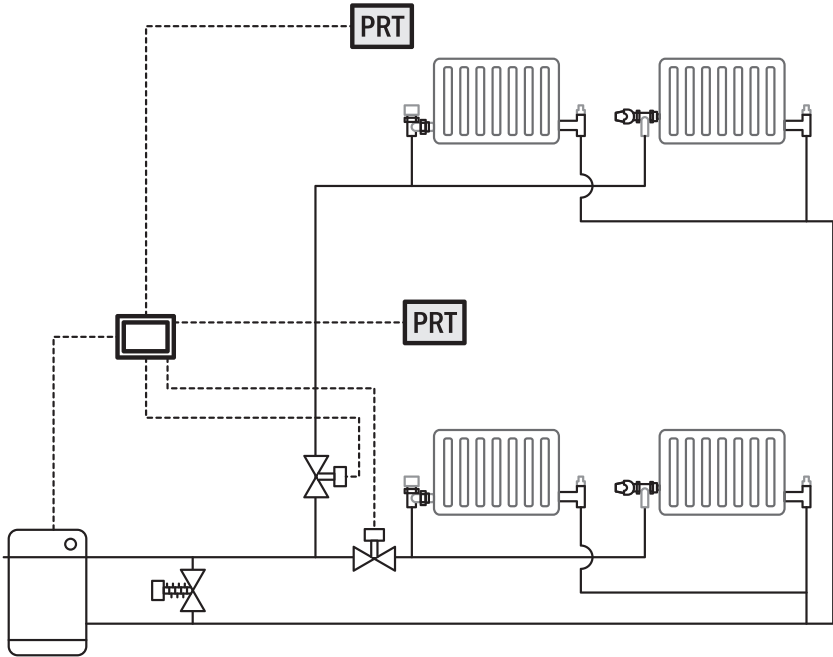





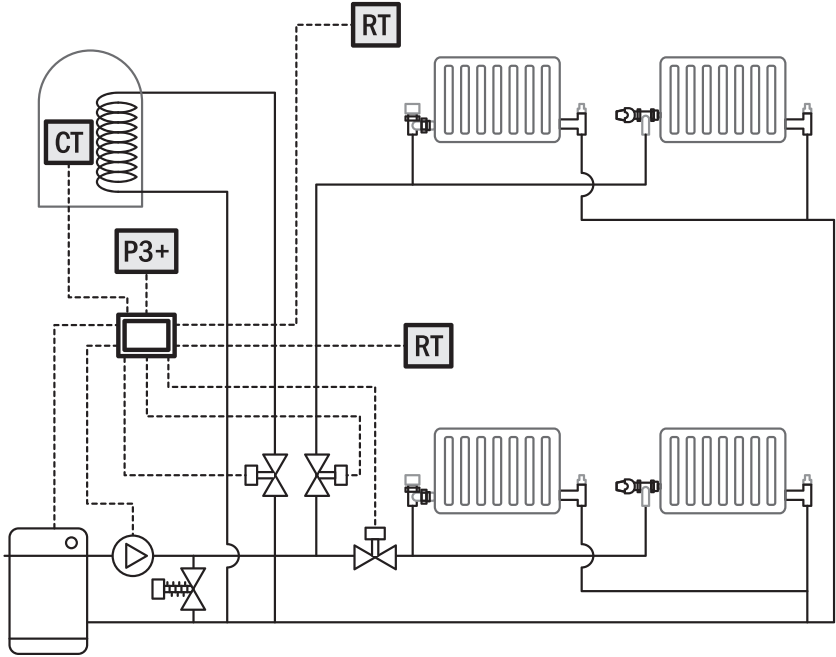

DIAGRAMS PROVIDED AS GUIDANCE ONLY, FINAL DESIGN SHOULD BE DECIDED UPON BY A QUALIFIED PLUMBER IN LINE WITH CURRENT PART L GUIDELINES.

COMBINATION BOILER

PROGRAMMABLE ROOM THERMOSTATS & TRV'S (150m²+)



- 
BOILER
- 
2 PORT
- 
3 PORT
- 
ABV
- 
WHEEL
HEAD
VALVE
- 
LOCK
SHIELD
VALVE
- 
THERMASTIC
RAD VALVE

- RT

ROOM
STAT
- PRT

PROG
ROOM
STAT
- P3+

MULTI
CHAN
PROG
- P2

TWO
CHAN
PROG
- T1

ONE
CHAN
PROG
- CT

CYL
STAT
- [Junction Box Icon]

JUNCT.
BOX
- WIRING

DIAGRAMS PROVIDED AS GUIDANCE ONLY, FINAL DESIGN SHOULD BE DECIDED UPON BY A QUALIFIED PLUMBER INLINE WITH CURRENT PART L GUIDELINES.

Electric Boilers

PART L COMPLIANT LAYOUTS

COMBINATION BOILER

TWIN ZONE PROGRAMMER, THERMOSTATS & TRV'S (150m²+)

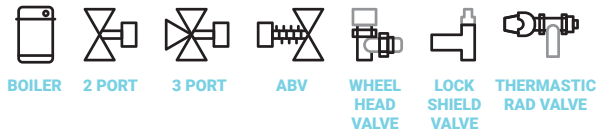
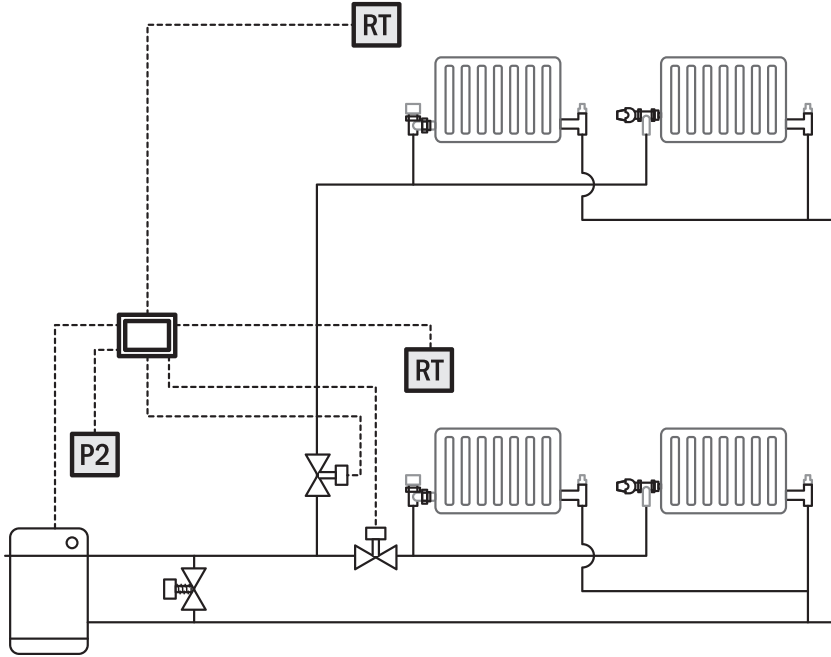

DIAGRAMS PROVIDED AS GUIDANCE ONLY, FINAL DESIGN SHOULD BE DECIDED UPON BY A QUALIFIED PLUMBER IN LINE WITH CURRENT PART L GUIDELINES.

WALL MOUNTING THE BOILER

IMPORTANT

When choosing a location to mount the boiler it is important that you consider clearance, servicing the boiler, and safe and suitable operation.

The boiler should be fitted out of the reach of children, people of deminished responsibility, and people who may otherwise access the boiler internals without the proper skills and qualifications as opening the boiler should only be done by a qualified electrician after first isolating the electrical supply. If there is the possibility that the boiler could be opened without first isolating the electrical supply then you must install it in a fashion that prevents access to the boiler, such as a lockable cupboard.

In terms of clearance strom recommend at least 100mm from all fixed obstructions on all sides of the boiler.

Please ensure that the designated wall for mounting the boiler has the structural integrity to support the unit when full. The following guidance is provided for sound solid brick wall mounting, your mounting may vary.

1. Using a drill create 6 holes as per the including wall mounting diagram. The upper holes should be $\Phi 8$ diameter, and the lower holes $\Phi 6$.
2. Secure the 3 supplied $\Phi 8$ expansion bolts into the top three holes.

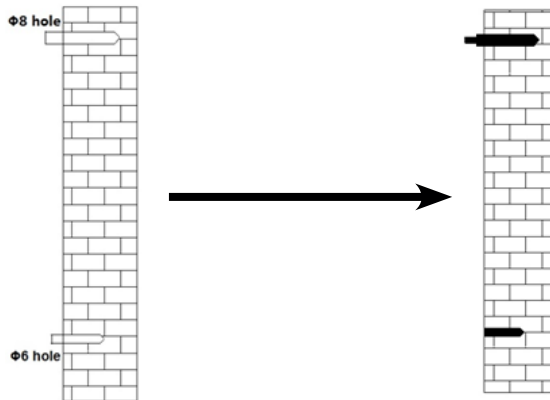

Electric Boilers

WALL MOUNTING THE BOILER

3. Hang the boiler from the top three bolts before securing the boiler to the wall using standard fastenings at the bottom.

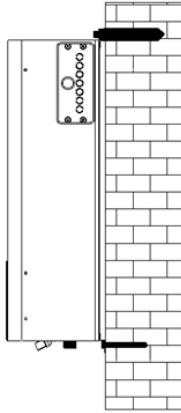

4. Please make sure that the boiler is now firmly fixed in position and unable to move. Failure to secure the boiler may cause damage to the wall and boiler in the future.

MAKING CONNECTIONS:

- The connections for flow and return must be carried out according to the colour scheme and labelling marked on the boiler.
- The connections for mains water inlet and outlet must be carried out according to the colour scheme and labelling marked on the boiler.
- When tightening or loosening threaded connections, always use suitable tools such as open-end adjustable spanners. Do not use pipe wrenches, extensions or unsuitable tools that may cause damage or water leaks.
- High temperature flexible hoses are recommended for all connections, however if you are using irons please ensure that you secure both connections and do not apply more torque than necessary as you may split in the internal pipework of the boiler or weaken it, both will render the warranty void and increases the chances of a leak that would not be covered by the warranty.

HEATING FLOW & RETURN:

These connections are $\frac{3}{4}$ " for connection to 22mm pipe. Suitable diameter service valves should be installed at the flow and return to allow the boiler to be isolated for maintenance without draining the entire heating system. We recommend flexi-hoses as overtightening irons may damage the boiler internals which is not covered under warranty.

HOT WATER INLET & OUTLET: (COMBINATION BOILERS ONLY)

These connections are $\frac{1}{2}$ " for connection to 15mm pipe with service valve on the inlet for flow restriction. We recommend flexi-hoses as overtightening irons may damage the boiler internals which is not covered under warranty.

PRESSURE RELIEF VALVE:

The boiler comes with a barb fitting for quick connection in temporary applications, however we recommend the removal of this to expose a $\frac{1}{2}$ " female connection, this can then be converted to 15mm copper pipe and discharged according to current building regulations.

Electric Boilers

WATER CONNECTIONS

FILLING POINT:

A convenient fill point has been added to the boiler called the “water replenishing valve”. A temporary connection should be made to this point when initially filling the boiler or topping the water pressure up. This must be closed once the system is up to pressure and the air has been purged. Alternatively, this can be left closed and a traditional filling loop can be used for filling of the heating system and replacing any water lost during servicing or bleeding the system. The filling loop should be installed in close vicinity to the boiler or connected to the water replenishing connection. The filling loop should be installed to current water regulations and should be removed after filling and the valves sealed with suitable caps.

FLUSHING:

The system must be flushed to 10% of mains PPM (chloride and otherwise) or lower to ensure that the water system is not detrimental to the lifespan of the boiler. If the boiler is being installed into an existing heating system, a power flush must be carried out on the radiators and pipework to remove any potential debris.

HEATING SYSTEM INITIAL FILL:

Ensure that both flow and return isolation valves fitted as part of your installation are fully open. Find the Automatic Airvent behind the pump and ensure that the cap is freely moving and not screwed down in the closed position. Connect the filling loop to the Water Replenishing connection, open the valve fully and allow the system to fill slowly until the pressure gauge reads between 1 and 1.5 bar, at which point the replenishing valve should be shut. Ensure that you add inhibitor to your system, refer the manufacturers guidance for dilution rates. For the moment please leave the filling loop connected until you have purged the air out of the system.

HOT WATER INITIAL FILL: (COMBINATION BOILERS ONLY)

Ensuring that the isolating valve before the cold water inlet is fully open, open all hot water taps on the hot water circuit 1 at a time and run until all air has ceased coming out of the tap, it is important to wait a moment until all spluttering has stopped. If any air remains in the hot water element of the boiler when power is turned on the water heating element can prematurely fail.

Electric Boilers

CHECK WATER CONNECTIONS

It is important not only to check for leaks on the pipework installed by yourself, but also to check the internals of the boiler for any leaks over a few hours after installing the boiler.

Every boiler is pressure tested inside our factory however after a long journey and installation it can sometimes be necessary to tighten connections when water escapes occur. Please do not unnecessarily tighten connections, or over tighten them, only as required in the few hours after initial installation.

If you are unable to check for leaks in the few hours after installation please drain down and only fill the system again when you have the time to do so. This applies to one circuit on a system boiler and both circuits on a combination boiler.

POWER SUPPLY:

The supply cable to the boiler should be of sufficient size to carry the load capacity required. It should be wired through a linked isolator switch with minimum contact gaps of 3mm in every pole, and the system protected by a suitably rated circuit breaker.

It is essential that the boiler is properly earthed, and the wiring tested to current IEE regulations.

The following table shows the specification for the full selection of Strom Boilers, please check carefully your model and read off from the table below. Calculations should always be done to ensure that the information is correct for your circumstances, as variances in installations can change the breaker size and or cable size, for instance voltage varies from property to property and does not necessarily follow any regional variances.

Rated Boiler Output	7kW	11kW	14.4kW	18kW	21kW	24kW
Single / Three Phase	Single	Single	Single	Three	Three	Three
Rated Voltage	230VAC	230VAC	230VAC	400VAC	400VAC	400VAC
Current (A) @ Rated Voltage	32	55	63	27.3	31.8	36.4
Minimum MCB/RCB (A)	40	63	63	32	40	40
Minimum Cable Size (mm²)	4	10	10	3 x 4.0	3 x 6.0	3 x 6.0

The terminal connection block is at the top right-hand side of the boiler and is accessible via the removal of the front panel. The supply cable should be safely routed to this point through the cable entry point at the top of the right-hand panel of the boiler.

Ensure the connection cables are correctly wired into the correct terminals and are securely in position.

CABLE TYPE:

For ease of installation Strom always recommend a multi strand high temperature flexible cable such as HO7 cable, please consult your electrical distributor, and always make sure that size of cable is correct for the number of amps used as different cables can have different ratings at different core sizes.

Electric Boilers

CONNECTING EXTERNAL THERMOSTAT

Because no programming or temperature control can be done by the boiler itself it is necessary to fit an external thermostat. It is recommended that you fit time and temperature control in the form of separate programmer and thermostat(s) or in the form of all in one programmable thermostat(s). More information can be found on system types on page 11.

The following information is provided as a guide only and refers to Strom manufactured heating controls, however you should follow the guidance of the manufacturer when connecting the thermostat to the Strom Boiler. We regret that we cannot offer any wiring advice of competitor products, and can only refer in those circumstances to the connections on our boiler.

BOILER WIRING:

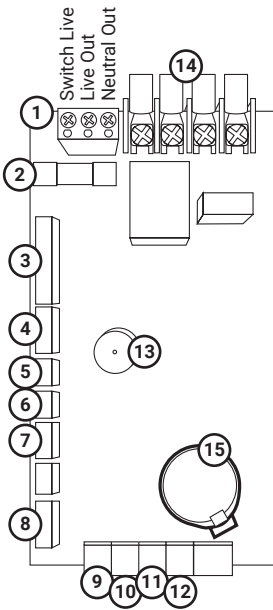

The PCB control board for the heating circuit is located in the right hand side of the boiler between the pump and the main electrical supply point.

- | | |
|------------------------------|--------------------------------|
| 1. Terminal Block | 9. Pressure Switch |
| 2. 6 Amp Fuse | 10. Heating Cut-out |
| 3. Heating Power Board | 11. Heating Flow Temperature |
| 4. Water Power Board | 12. Heating Return Temperature |
| 5. Water Outlet Temp. Sensor | 13. Buzzer |
| 6. Water Inlet Temp. Sensor | 14. Heat Exchanger Power |
| 7. Water Flow Sensor | 15. Internal Memory Battery |
| 8. Touch Control Panel | |

THERMOSTAT WIRING:

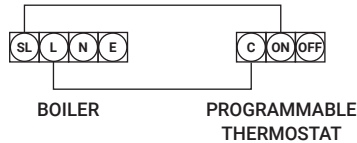

All wiring must be carried out in accordance with current IEE BS7671 wiring regulations.

All electrical connections must be made by a qualified electrician.

CHECKING ELECTRICAL CONNECTIONS

It is important before powering on the boiler for the first time that all electrical connections are checked, this is not only your own connections but also the factory made ones too. Whilst all factory made connections are tested at the factory it is possible that during transit or installation connections may have come loose.

For Screwed connections please check for cable movement and tighten with a Screwdriver if necessary and for ribbons and push plastic connectors please gently apply pressure to make sure they are firmly seated. Please check the following connections:

1. The main power supply connections to the unit, both installer and factory made.
2. The spade connections labelled as number 14 on the PCB control board opposite.
3. The thermostat connections labelled as number 1 on the PCB control board opposite.
4. Push connectors labelled 3 - 12 if present on the PCB control board opposite.
5. All terminations on the heating element (these are the braided connections).
6. All connections made on the PCB above the heating element (these are braided connections).
7. All terminations on the hot water elements (these are the braided connections) - Combi only.
8. All earth terminations both factory made and installer made.



Electric Boilers

POWERING ON THE BOILER

IMPORTANT

Before powering on the boiler for the first time please make sure you have completed the following:

1. All aspects of the manual preceding this section have been completed as instructed.
2. The fitted thermostat or programmer is set to the off position, or where off is not possible the thermostat is set to the lowest possible temperature.
3. Make sure that any power isolators inside the boiler are turned on, the boiler casing is secured, and the lower flap is in the upright position.
4. The boiler can now be powered on by activating power at the breaker in the consumer unit. The boiler will initially power on in standby mode. The power button will bring the boiler out of standby mode, but for the time being leave the boiler in this mode so that the boiler settings can be configured.

SET THE BOILER PARAMETERS

The boiler has 3 key parameters that need to be set in order to make the boiler function correctly:

CLOCK

The time function displays the Time on the front of the boiler during normal operation, this helps the homeowner to confirm that the programmer has been programmed correctly by letting them see the time the boiler has become activated.

BOILER FLOW TEMPERATURE

The boiler flow temperature displays on the boiler as "HEAt". The default position is 65°C, this should however be set to the design temperature of the heating system, in many cases on existing properties with standard radiator systems 65°C will be correct, however underfloor heating systems and low temperature radiator systems may be as low as 35°C. If this is not adjusted on set correctly the boiler may cycle and experience overheating problems. If a hot water cylinder is present most systems would be remain set at 65°C

BOILER DIFFERENTIAL

The boiler differential temperature displays on the boiler as "dIFF". When the boiler finally reaches the flow temperature set on the boiler the heat exchanger will turn off to allow heat to dissipate in the system. It will only fire again when the temperature drops by the number degrees set in this setting. For example if FLOW is set as 65°C and dIFF is set as 15°C when the boiler flow hits 65°C it will not reactivate until 50°C is reached. Default position for this setting is 15°C.

CHANGING THE SETTINGS:

To change the settings **with the boiler still in the standby position** press and hold the Menu button (see page 10) until "CLOCK" begins to flash, using the up and down button press set the time, pressing the menu button again to move from hours to minutes. If the boiler doesnt enter the admin mode it is likely the boiler is not in the standby position, press and hold the power button until the boiler enters standby and try again.

Pressing the Menu button again will cause HEAt to be displayed, again using the up and down button set the heat output to the correct design temperature.

Finally press the Menu button again and dIFF will be displayed, finally using the up and down buttons for the final time set the heat differential of the boiler.

Press and hold the power button for a few seconds waiting for the boiler to beep and for the Admin menu to be exited.

Electric Boilers

SET PUMP SPEED & PURGE AIR

Before moving the boiler out of standby mode please check and complete the following actions:

1. The boiler has been properly configured in the previous step.
2. The airvent on the pump is open with the dust cap moving freely.
3. Set the pump to pump speed one, this for many installations should be adequate.

The boiler can no be activated, press and hold the power button until the boiler beeps and exits standby mode. The first thing you will notice is the flashing Thermostat Status Symbol, this means that currently there is no demand from the thermostat for heating.

Activate the thermostat so that it is now calling for heat, the Thermostat Status Symbol should now remain static and lit. The pump will fire up and after a few seconds the ignition symbol should illuminate and heat should start being produced.

While the pump is running you should begin to purge all air from the system by bleeding all radiators and airvents in the system. Once bled the system should run almost silently with very little noise coming from the boiler or pump. Once all air is purged you can begin to alter the pump speed to suit your needs, normally a 15 to 20 degree differential between the flow and return is desirable, and the pump speed can be increased or decreased to achieve this differential.

You should also now take the time to set the Automatic Bypass Valve on the system, with all TRV's on the system open and the pump set at the correct speed set the Autobypass Valve to only just closed, now confirm you have the correct setting by closing only one of the TRV's, the bypass valve should now start to allow small amounts of water to pass.

Finally now that all the air has been purged from the system check the final pressure reading of the heating circuit, and top up if required. Once set please disconnect the filling loop or water supply to the water replenishment valve, and ensure that all connections are capped off until required again at a future date.

SET DHW FLOW & TEMPERATURE

COMBINATION BOILERS ONLY

The hot water side of the electrical combination boiler relies on setting the correct flow rate of water going in to the unit, if the water going in to the unit is too fast then the unit will be unable to cope with the demand and the water will come out cold. You should aim to set your boiler to approximately the following flowrates, you can do this by restricting the isolation valve fitting on the cold water of the inlet during installation.

Rated Boiler Output	7kW	11kW	14.4kW	18kW	21kW	24kW
Recommended Flowrate (LPM)	4	6	7	10	12	13

With the hot water tap open and running the temperature of the hot water outlet can now be set on the boiler by using the up and down button. The temperature cannot be adjusted without a hot tap being open. Remember this setting does not guarantee the output, it only sets the maximum possible output, the output temperature will rely on the flow rate going in to the boiler as above.

Electric Boilers

TESTING HEATING & HOT WATER

Before completing the installation checklist please take the time to check the Heating Circuit and Domestic Hot Water Circuit (Combi's only). This final check is important to ensure that you do not have to reattend site at a later date to correct any issues.

HEATING TEST

1. Set the thermostat to a temperature approximately 4-5 degrees above current room temperature and ensure that the boiler fires.
2. Leave the boiler running for several minutes and check that the radiators are beginning to get warm.
3. After approximately 15 minutes check the temperature differential between the flow and return is approximately 15 to 20°C, if not please refer to setting the pump speed on page 34.
4. Wait until the thermostat reaches temperature and deactivates the boiler.
5. Now set the thermostat 4-5 degrees higher and waiting for a few minutes check to see if the boiler successfully fires again.
6. Return the thermostat to its required position to complete testing.

HOT WATER TEST

1. Open a hot water tap and ensure that the boiler fires.
2. Give the boiler a few minutes to reach temperature.
3. Check that the tap is outputting water at the correct temperature, if not please refer to setting the hot water flow and temperature on page 35.
4. Close the hot water tap to complete testing.

PLUMBER TO COMPLETE...

COMPANY NAME:

PLUMBERS NAME:

COMPANY ADDRESS:

COMPANY TELEPHONE:

DATE OF INSTALLATION: / / PRODUCT CODE:

WAS THIS A EXISTING INSTALL OR NEW INSTALL? EXISTING NEW INSTALL

HOW MANY HEATING ZONES ARE INSTALLED? 1 2 3+

HAS THE FILLING LOOP BEEN REMOVED & CAPPED OFF? YES NO

WAS AN ABV FITTED? AT WHAT SETTING? YES NO SETTING:

WHAT IS THE HEATING PRESSURE SET AT? . Bar

WHAT IS THE INCOMMING MAINS PRESSURE? . Bar

WHAT HAS THE BOILER FLOW TEMPERATURE BEEN SET AT? °C

WHAT HAS THE BOILER DIFFERENTIAL TEMP. BEEN SET AT? °C

WHAT PUMP SPEED HAS BEEN SET ON THE BOILER?

NOTES:

BY SIGNING YOU AGREE THAT YOU HAVE INSTALLED THE BOILER IN ACCORDANCE WITH THIS MANUAL AND THAT THE BOILER IS WORKING AS INTENDED WITHOUT ANY LEAKS AND ALL INSTALLER MADE AND FACTORY MADE CONNECTIONS HAVE BEEN CHECKED.

SIGNED: _____ DATE: _____

Electric Boilers

ELECTRICIANS CHECKLIST

ELECTRICIAN TO COMPLETE...

COMPANY NAME:

ELECTRICIANS NAME:

COMPANY ADDRESS:

COMPANY TELEPHONE:

DATE OF INSTALLATION: / /

WHAT IS THE INCOMING MAINS VOLTAGE AT THE FUSE BOARD? VAC

WHAT IS THE INCOMING MAINS VOLTAGE AT THE APPLIANCE? VAC

WHAT SIZE BREAKER HAS BEEN FITTED FOR THE BOILER? AMPS

WHAT IS THE DRAW OF THE APPLIANCE FOR HEATING? AMPS

WHAT IS THE DRAW OF THE APPLIANCE FOR HOT WATER? AMPS

WHAT SIZE CABLE WAS INSTALLED TO THE APPLIANCE? . MM²

WHAT IS THE APPROXIMATE CABLE RUN TO THE BOILER? M

WHAT TYPE OF CABLE HAS BEEN USED?

NOTES:

BY SIGNING YOU AGREE THAT YOU HAVE INSTALLED THE BOILER IN ACCORDANCE WITH THIS MANUAL AND THAT THE BOILER IS WORKING AS INTENDED WITHOUT ANY LEAKS AND ALL INSTALLER MADE AND FACTORY MADE CONNECTIONS HAVE BEEN CHECKED.

SIGNED: _____ DATE: _____

ERROR CODE	POTENTIAL CAUSE	SOLUTION
E0	Heating system contains a lack of water or pressure is not sufficient for circulation.	Add treated water to the heating system and bring the pressure to a suitable level.
	Water pressure switch is damaged.	Check the pressure for the system is above 1 bar, and then carry out a continuity test across the pressure sensor.
	Loose connection for pressure switch.	Check the wiring and reseal connection if loose.
E1	Loose connections between heating outlet temperature sensor & PCB	Check the wiring and reseal connection if loose.
	Faulty temperature sensor for heating outlet.	Call Strom on 0333 344 24 74
E2	Loose connection between the heating return temperature sensor & PCB	Check the wiring and reseal connection if loose.
	Faulty temperature sensor for heating return.	Call Strom on 0333 344 24 74
E3	Heating system flow temperature overheating.	Check that there is sufficient system circulation. If the boiler has been set for temperatures in excess of 75°C please reduce to between 70 & 75.
E4	Heat exchanger overheating.	The boiler will automatically begin circulating again once the heat exchanger has cooled.
E5	Flow sensor failure.	Call Strom on 0333 344 24 74
	Pump failure.	
E6	Loose connection between domestic hot water outlet temp. sensor & PCB.	Check the wiring and reseal connection if loose.
	Faulty temp. sensor for domestic hot water outlet.	Call Strom on 0333 344 24 74
E7	Domestic hot water temperature greater than 73°C	Reduce temperature setting on the boiler, or increase the mains water flow rate.
E8	Loose connection between domestic hot water inlet temp. sensor & PCB	Check the wiring and reseal connection if loose.
	Faulty temperature sensor for domestic hot water inlet	Call Strom on 0333 344 24 74

Electric Boilers

FAULT FINDING

E9	Poor water circulation	<ul style="list-style-type: none"> - Check ABV is fitted and set correctly - Check pump speed is set correctly - Check there is no air in the system - Ensure all isolation valves are open
	Loose PCB Connection	Check connection between dedicated heating flow sensor and PCB
EA	Power supply to the boiler is too high.	Check supply voltage & correct. Re-check all wiring to the unit.
Indicators on the control panel are off.	Power supply failure.	Re-check all wiring to the unit.
	Loose connection from the control board to main PCB.	Check the wiring and reseal connection if loose.
	Display board failure.	Call Strom on 0333 344 24 74
Control panel is not registering touch commands.	Display board failure.	
Heating temperature is low/the device is not heating up.	Heating element failure	
	Thermal cut-out failure	
	Triac burnout	
	Control board failure	
The hot water for the showers/taps is not hot enough.	The mains water flow rate is too high.	Reduce water flow to a suitable level to allow element to heat incoming water. If problem persists please contact Strom on 0333 344 24 74.
	The temperature setting for the boiler is too low.	Adjust the temperature setting via the control panel on the boiler.

STROM BOILERS DO NOT REQUIRE PARTICULAR MAINTENANCE OTHER THAN THE FOLLOWING:

The heating system must be filled and maintained when the water is cold, between a pressure of 1 – 1.5 bar. Frequent refilling of the system can cause scaling, corrosion and damage to a heating system and should be avoided wherever possible. Regular pressure loss could be indicative of a leak within the system and should be investigated. When the system is refilled always check the level of inhibitor in the system and re-fill where necessary.

UNDER NO CIRCUMSTANCES SHOULD THE BOILER BE SWITCHED ON WHEN THE SYSTEM IS DRY.

The boiler contains an installed frost-protection program. For this to operate, power must be supplied to the boiler at all times. Anti-freeze can be added to the heating system (no more than 20% by volume) if the boiler is going to be stood unused for long periods of time. Otherwise, the boiler should be disconnected from the electricity supply and the system fully drained to avoid any frost damage.



Electric Boilers

WARRANTY INFORMATION

All Strom products are supplied in accordance with standard Terms & Conditions (available on request or via our website). This Policy also applies in addition to our terms and conditions to any Strom Electric Boilers and by fitting this product you are agreeing to be bound by these Terms & Conditions and this Policy. This Policy sets out the Warranty Period and exclusions which apply to Electric Boilers, for other products please see our website or their corresponding manuals. This Policy is subject to our Standard Terms and Conditions and should be read in conjunction with those terms. We reserve the right to amend this policy at any time.

Warranty Details:

Subject to the exclusions set out below and any applicable points in our Terms and Conditions, faulty parts and products will be replaced or repaired free of charge by Strom, or one of its representatives during the applicable Warranty Period. Where work is carried out by personnel not associated with Strom, or without Strom's knowledge we will be unable to cover the associated costs, parts, and labour charges. If Strom or its representatives are unable to attend your property in a timely manor we reserve the right to allow third parties to undertake the work once a pre-agreed cost has been agreed with Strom directly (agreements via third parties will not be accepted).

Exclusions:

1. This policy only applies where:

- i. The product is installed and used strictly in accordance with the Terms and Conditions and the instructions supplied with the product; and
- ii. the failure is not due to accident, misuse, abuse, unsuitable water conditions (including contaminants or inappropriate water pressure), limescale build up, or to any alteration, modification or repair by any party not expressly nominated by Strom.
- iii. Unsuitable water conditions include:
 - a) Private water supplies that are not regulated by water authorities
 - b) Hard water that is left untreated
 - c) Water additives that lead to product corrosion
 - d) The absence of corrosion inhibitor in heating circuits

2. This warranty does not cover damage resulting from non-operation of the product or consequential damage to any other goods, furnishings or property.

3. This warranty does not apply to any consumables associated with the product.

4. Installations that have not been carried out by person/s that do not hold the relevant qualifications required in their field to carry out the works undertaken. An electrical installation certificate from a qualified electrician must be provided for your install, failure to supply this certificate will render any warranties null and void.

5. Warranties are non-transferable and must be purchased as new from one of our distributors.

Warranty Periods:

All Strom Boilers comes with a standard out of box warranty of 1 year, however by completing the included promotional guarantee procedure within 45 days of purchase (please see warranty documentation) the warranty will be extended to the offered promotional duration free of charge. The promotional period may vary dependent on supplier, model, or package purchased. All details set out in the included warranty documentation.

Electric Boilers

CONDITIONS OF SALE

1. DEFINITIONS

"Buyer" means the person who accepts a quotation of the Company for the sale of the Goods or whose order for the Goods is accepted by the Company
"Company" means Ström Limited

"Conditions" means the terms and conditions of sale set out in this document and any special terms and conditions agreed in writing by the Company and the Buyer
"Contract" means the contract for the purchase and sale of the Goods
"Goods" means the goods which the Company is to supply and which the Buyer agrees to buy in accordance with these conditions

"Price" means the price for the Goods including transport and insurance (if any)
1.2 Any reference in these Conditions to any provision of a statute shall be construed as a reference to that provision as amended, re-enacted or extended at the relevant time
1.3 The headings in these Conditions are for convenience only and shall not affect their interpretation

2. BASIS OF SALE

2.1 The Company shall sell and the Buyer shall purchase the Goods in accordance with:

2.1.1 the Company's quotation (if provided by the Company and accepted by the Buyer) or
2.1.2 (if the Company does not submit a quotation and following a request or purported order from the Buyer for Goods) in accordance with the Company's offer to the Buyer (if accepted by the Buyer) subject in either case to these Conditions, which shall govern the Contract to the exclusion of any other terms, conditions to which any such quotation or offer is accepted, or purported to be accepted

2.2 Any variation to these Conditions (including any special terms and conditions agreed between the parties) shall be inapplicable unless agreed in writing by the Company
2.3 Any advice or recommendation given by the Company or its employees or agents to the Buyer or its employees or agents as to the storage application or use of the Goods which is not confirmed in writing by the Company is followed or acted upon at the Buyer's own risk and accordingly the Company shall not be liable for any loss or damage which is not so confirmed
2.4 Any typographical error or other error or omission in any price list, literature quotation or price schedule submitted by the Company or any information issued by the Company shall be subject to correction without any liability on the part of the Company

2.5 All specifications, drawings, particulars of weight and dimension and performance data contained in any of the Company's literature are approximate only

2.6 The Company reserves the right to improve and/or modify any specifications, designs and dimensions without notice

2.7 For the avoidance of doubt nothing in these Conditions or any Contract shall confer on any third party any benefit or the right to enforce any term of the Conditions or any Contract whether pursuant to the Contracts (Rights of Third Parties) Act 1999 or otherwise

3. THE PRICE AND PAYMENT

3.1 The Price shall be either:-
3.1.1 the Company's quoted price which shall only be valid for 30 days from the date after which the Price may be altered by the Company and shall be subject to the Company requiring, or
3.1.2 where no price has been quoted the Price listed in the then current price list of the Company sent by the Company to the Buyer from time to time

3.2 Except as otherwise stated in the Company's quotation or in any price list of the company or otherwise stated between the Buyer and the Company, all prices are given by the Company to include the Company's charges for transport and insurance

3.3 The Price and any other sums payable by the Buyer to the Company is exclusive of any applicable Value Added Tax, which the Buyer shall be additionally liable to pay to the Company

3.4 Subject to any special terms agreed in writing between the Buyer and the Company, the Company may invoice the Buyer for the Price of the Goods on or at any time after delivery of the Goods, (or any instalment of the Goods) unless the goods are to be collected by the Buyer or the Buyer expressly fails to take delivery of the Goods, in which event the Buyer shall be entitled to invoice the Buyer for the Price at any time after the Company has notified the Buyer that the Goods are ready for collection or (as the case may be) that the Buyer has tendered delivery of the Goods

3.5 Save as otherwise agreed in writing, payment of the Price and VAT shall be due within the agreed period from the date of the invoice without deduction or set off. Time for payment shall be of the essence

3.6 If the Buyer fails to make any payment on the due date then without prejudice to any other right or remedy available to the Company the Company shall be entitled to:

3.6.1 cancel the contract or suspend any further deliveries to the Buyer
3.6.2 appropriate any payment made by the Buyer to such of the Goods (or the Goods supplied under any other contract between the Buyer and the Company) as the Company may think fit (notwithstanding any purported appropriation by the Buyer) and
3.6.3 charge the Buyer interest (both before and after any judgement) on the amount unpaid at the rate of 8% per annum above the base rate or a further rate of base rate from time to time until payment in full is made (a part of a month being treated as a full month for the purpose of calculating interest)

4. THE GOODS

4.1.1 The quantity and description of the Goods shall be as set out in the Company's quotation or in the Company's offer (as the case may be); and
4.1.2 the quality of the Goods shall be as specified in the Company's quotation or (where there is no quotation) in the Company's literature and brochure for the Goods in question

4.2 The Buyer shall be responsible for the Company for ensuring the accuracy of the terms of any order and any information supplied for the Company as to its requirements (including but without limitation the use to which the Goods will be put) and any applicable specification submitted by the Buyer and for giving the Company any necessary information relating to the Goods within a sufficient time to enable the Company to perform the Contract in accordance with its terms

4.3 If the Goods are to be manufactured or any process is to be applied to the Goods by the Company in accordance with a specification submitted by the Buyer the Buyer shall indemnify the Company against all trade marks or other distinctive demands, liabilities and expenses awarded against or incurred by the Company in connection with or paid or agreed to be paid by the Company in settlement of any claim for infringement of any trade mark or other distinctive demands, liabilities or intellectual property rights of any other person which results from the Company's use of the Buyer's specification or from compliance by the Company with the Buyer's instructions which are not expressly reserved

4.4 No order which has been accepted by the Company may be cancelled by the Buyer except with the agreement in writing of the Company and on terms that any deposit paid shall be repaid and that the Buyer shall indemnify the Company in full against all loss (including loss of profit costs (including the cost of all labour and materials used) damages and expenses incurred by the Company in carrying out any work under the Goods or otherwise) as a result of cancellation

4.5 All designs, sketches, or similar articles supplied by or submitted in confidence to the Company shall remain the property of the Company and may not be disclosed by or used by, copied or otherwise reproduced by the Buyer without the prior written consent of the Company

5. DELIVERY OF GOODS

5.1 Unless otherwise agreed in writing the Company shall deliver the Goods to such delivery address as is specified in the Buyer's order at such time as the Goods or part thereof (as the case may be) are ready for delivery

5.2 The Buyer shall be responsible for offloading the Goods at the delivery address and shall advise the Company of any special unloading, byelaws or rules relating to parking or loading of vehicles at the delivery address

5.3 The Buyer shall be responsible for ensuring that access to the delivery address is wholly by a road with a surface capable of withstanding the weight and size of a vehicle carrying the Goods

5.4 Any dates quoted for delivery of the Goods are approximate only and the Company shall not be responsible for any delay in delivery of the Goods or any loss caused Time for delivery shall not be of the essence unless previously agreed by the Company in writing The Goods may be delivered by the Company in advance of

the Delivery Date upon giving reasonable notice to the Buyer
5.5 Where the Goods are to be delivered in instalments each delivery shall constitute a separate contract and failure by the Company to deliver any one or more instalments in accordance with these Conditions shall not constitute a breach of any other instalment and the Buyer shall be obliged to accept and pay for any one or more instalments shall not entitle the Buyer to treat the Contract as a whole as repudiated

5.6 Where any reason whatsoever to take delivery of the Goods fails to give the Company adequate delivery instructions at the time stated for delivery (other than by reason any cause beyond the Buyer's reasonable control or by reason of the Buyer's fault) then the Buyer shall be liable for any other right or remedy available to the Company the Buyer may:

5.6.1 store the Goods until actual delivery and charge the Buyer for the reasonable costs (including re-delivery) of returning the Goods to the Company's premises, storage and for transport, packaging and insurance for re-delivery of the Goods; or
5.6.2 sell the Goods at the best price readily obtainable and after deducting all reasonable storage and selling expenses account to the Buyer for the excess over the Price or charge the Buyer for any shortfall below the Price

5.8 Goods may not be returned to the Company except by prior written permission of an authorised officer of the Company and such return shall be subject to payment by the Buyer of handling and re-stocking charges, transport and all other costs incurred by the Company the Buyer may:

6.1 RISK AND RETENTION OF TITLE
6.1.1 goods supplied by the Company shall be at the Buyer's risk immediately upon delivery to the Buyer or into custody on the Buyer's behalf or to the Buyer's Order. The Buyer shall effect adequate insurance of the goods against all risks to the full invoice value of the goods, such insurance to be effective from the time of delivery until property in the goods shall pass to the Buyer as hereinafter provided

6.2 property in the goods supplied hereunder will pass to the Buyer when full payment has been made by the Buyer to the Company for:-
6.2.1 the Goods, and
6.2.2 all other goods the subject of to all other contract between the Buyer and the Company which, at the time of payment of the full price of the goods sold under this contract, are to be returned to the Buyer but not paid for in full

6.3 until property in the goods supplied hereunder passes to the Buyer in accordance with paragraph (3) above

6.4 the Buyer shall be liable in a fiduciary capacity for us and shall store the same separately from any other goods in the Buyer's possession and in a manner which enables them to be identified as our goods

6.5 the Buyer shall be liable to return the goods to the Company should the Company authorities representative so request. All the necessary incidents of the contract shall be deemed to be retained by the Company until the Goods are returned to the Company in accordance with paragraph (3) above

6.4 The Buyer's right to return the goods shall be forthwith upon the happening of any of the following events, namely:-
6.4.1 the Buyer's failure to make payment in full for the goods in the time stipulated in clause 3 hereof

6.4.2 If the Buyer, not being a company, commits any act of bankruptcy, makes a request to the Buyer or into custody on the Buyer's behalf or to the Buyer's Order, entitle a petition for a Bankruptcy Order to be presented

6.4.3 If the Buyer, being a company, does anything or fails to do anything which would constitute an administration or an administration order or the appointment of any assets or which would entitle any person to present a petition for winding up or to apply for an administration order

6.5 If the Buyer or the Company is an irrevocable licence to enter to assist the Buyer or premises owned or occupied by the Buyer or in the possession of the Buyer for the purposes of repossessing and recovering any such property of the Company or to exercise the powers conferred by the Company on the Buyer shall not be responsible for and the Buyer will indemnify the Company against all expenses incurred by the Buyer in connection with the exercise of the powers conferred by the Company on the Buyer in connection with the exercise of the powers conferred by the Company on the Buyer

6.6 The Buyer shall be responsible for the goods which it was not reasonably practicable to avoid

6.7 notwithstanding paragraph (3) hereof and subject to paragraph (3) hereof, the Buyer shall be permitted to sell the goods to third parties in the normal course of business. In this respect the Buyer shall act in the capacity of the Companies (6.1) and (6.2) and the proceeds of such sale shall be paid to the Company

6.6.1 shall be held in trust for us in a manner which enables such proceeds to be identified as such, and:-
6.6.2 the Buyer shall indemnify the Company against all expenses incurred by the Company in connection with the exercise of the powers conferred by the Company on the Buyer in connection with the exercise of the powers conferred by the Company on the Buyer

6.7.1 the Buyer shall indemnify the Company in connection with the exercise of the powers conferred by the Company on the Buyer in connection with the exercise of the powers conferred by the Company on the Buyer

6.8.2 take all necessary steps to prevent title to the goods from passing to the landlord of such land or building

6.8.3 forthwith inform the Company in writing of such affliction and of the address of the land or building concerned. The Buyer warrants to repair and make good any defects in such land or building and to indemnify the Company against all loss damage or liability the Company may incur or sustain as a result of affliction or removal

6.9 The Buyer shall indemnify the Company against all loss damage or liability the Company may incur or sustain as a result of affliction or removal

6.9.1 The Buyer shall indemnify the Company against all loss damage or liability the Company may incur or sustain as a result of affliction or removal

6.9.2 The Buyer shall indemnify the Company against all loss damage or liability the Company may incur or sustain as a result of affliction or removal

6.9.3 The Buyer shall indemnify the Company against all loss damage or liability the Company may incur or sustain as a result of affliction or removal

6.9.4 The Buyer shall indemnify the Company against all loss damage or liability the Company may incur or sustain as a result of affliction or removal

6.9.5 The Buyer shall indemnify the Company against all loss damage or liability the Company may incur or sustain as a result of affliction or removal

6.9.6 The Buyer shall indemnify the Company against all loss damage or liability the Company may incur or sustain as a result of affliction or removal

6.9.7 The Buyer shall indemnify the Company against all loss damage or liability the Company may incur or sustain as a result of affliction or removal

6.9.8 The Buyer shall indemnify the Company against all loss damage or liability the Company may incur or sustain as a result of affliction or removal

6.9.9 The Buyer shall indemnify the Company against all loss damage or liability the Company may incur or sustain as a result of affliction or removal

6.9.10 The Buyer shall indemnify the Company against all loss damage or liability the Company may incur or sustain as a result of affliction or removal

6.9.11 The Buyer shall indemnify the Company against all loss damage or liability the Company may incur or sustain as a result of affliction or removal

6.9.12 The Buyer shall indemnify the Company against all loss damage or liability the Company may incur or sustain as a result of affliction or removal

6.9.13 The Buyer shall indemnify the Company against all loss damage or liability the Company may incur or sustain as a result of affliction or removal

6.9.14 The Buyer shall indemnify the Company against all loss damage or liability the Company may incur or sustain as a result of affliction or removal

6.9.15 The Buyer shall indemnify the Company against all loss damage or liability the Company may incur or sustain as a result of affliction or removal

6.9.16 The Buyer shall indemnify the Company against all loss damage or liability the Company may incur or sustain as a result of affliction or removal

6.9.17 The Buyer shall indemnify the Company against all loss damage or liability the Company may incur or sustain as a result of affliction or removal

6.9.18 The Buyer shall indemnify the Company against all loss damage or liability the Company may incur or sustain as a result of affliction or removal

6.9.19 The Buyer shall indemnify the Company against all loss damage or liability the Company may incur or sustain as a result of affliction or removal

6.9.20 The Buyer shall indemnify the Company against all loss damage or liability the Company may incur or sustain as a result of affliction or removal

implied by Section 12 of the Sale of Goods Act 1979 shall not be limited
7.5 Subject as expressly provided in these Conditions all other warranties conditions or terms whether implied by statute or common law or otherwise are hereby excluded

7.6 If the Company fails to deliver the Goods for any reason other than any cause beyond the Company's reasonable control or the Buyer's fault then the Company shall only be liable to the Buyer for the price of the Goods and shall be liable to the excess (if any) of the cost to the Buyer (in the cheapest available market) similar goods to replace those not delivered over the Price of the Goods

7.7 The Buyer shall examine all Goods delivered forthwith following delivery. Any claim by the Buyer which is based on any defect in the quality or condition of the Goods or their failure to correspond with specification shall (whether or not delivery refused by the Buyer) be notified to the Company within 7 days from the date of delivery or (where the defect or failure was not apparent on reasonable inspection) within a reasonable time after discovery of the defect or failure (if delivery is not refused and the Buyer does not notify the Company accordingly) the Buyer shall not be entitled to reject the Goods and the Company shall have no liability for such defect or failure and the Buyer shall be bound to pay the Price as if the Goods had been delivered in accordance with the Contract. No event shall be treated as entitling the Buyer to reject the Goods on the basis of any defect or failure which is so slight that it would be unreasonable for the Buyer to reject them

7.8 The Company shall be entitled to examine any Goods which are the subject of any claim by the Buyer and to remove such Goods or any part thereof for testing. No tests carried out by the Buyer will be recognised by the Company unless carried out strictly in accordance with a method previously agreed by the Company as being suitable for the purpose

7.9 Where any valid claim in respect of any of the Goods which is based on any defect in the quality or condition of the Goods or their failure to meet specification is notified to the Company in accordance with these Conditions the Company shall be entitled to repair or replace the Goods or to refund to the Buyer (or a proportionate part of the Price) but the Company shall have no further liability to the Buyer

7.10 Where failed Goods are returned to the Company and subsequently found to have no fault found or failed due to reasons) outside these terms and conditions, the Company reserves the right to return the Goods to the Buyer

7.11 Without prejudice to the provisions of clauses 7.5, 7.6, 7.7, 7.9 and 7.10 the Buyer shall indemnify the Buyer under or in connection with the Contract and shall not be entitled to recover the Price of the Goods

7.12 The Company shall not be liable to the Buyer or be deemed to be in breach of the contract if the Buyer fails to deliver in performing or any failure to perform any of the Company's obligations in relation to the Goods (if the delay or failure was due to any cause beyond the Company's reasonable control) without limiting the foregoing, the following shall be regarded as causes beyond the Buyer's reasonable control

7.12.1 act of god, explosion, flood, pest, or inclement weather, fire or accident;
7.12.2 war or threat of war, sabotage, insurrection, civil disturbance or requisition;
7.12.3 acts, restrictions, regulations, by-laws, prohibitions or measures of any kind on the part of any Government or authority having jurisdiction of the Company;
7.12.4 imports or exports, regulations or embargoes;
7.12.5 strikes, lockouts or other industrial action or trade disputes (whether or not the employees of the Company)

7.12.6 difficulties in obtaining raw materials, labour, fuel, parts or machinery;
7.12.7 power failure, failure of tele-communications links, failure or breakdown of plant, machinery or equipment;
7.12.8 theft or malicious damage;
7.12.9 defaults for any reason whatsoever of suppliers or sub-contractors of the Company

7.12.10 incompleteness or inaccuracy of any technical information which it is the responsibility of the Buyer to provide

8. INSOLVENCY OF THE BUYER

8.1 This clause applies if the Buyer is a composition or voluntary arrangement with its creditors (being an individual or firm) becomes bankrupt or (if the company) becomes subject to an administration order or seeks an out of court route into administration goes into liquidation (whether or not the Company is a creditor of the Buyer) or reconstruction or a moratorium comes into force in respect of the Buyer (within the meaning of the Insolvency Act 1986), or

8.2 an insolvency administrator is appointed to receive or manage or administer or administrator is appointed of any of the property or assets of the Buyer, or

8.3 the Buyer ceases or threatens to cease to carry on business or

8.4 the Buyer reasonably apprehends that any of the events mentioned above is about to occur in relation to the Buyer and notifies the Buyer accordingly

8.5 If this clause applies then without prejudice to any other right or remedy available to the Company the Company shall be entitled to stop any Goods in transit, cancel the Contract or suspend any further deliveries under the Contract without any liability to the Buyer and if the Goods have been delivered but not paid for the Price shall become immediately due and payable notwithstanding any previous agreement or arrangement to the contrary

8.6 HEALTH AND SAFETY INFORMATION
The Buyer agrees and undertakes with the Company to ensure that the provisions of all instruction manuals including health and safety instructions and any other information or document relating to the use of the Goods provided by the Company with the Goods are fully implemented so as to ensure so far as is reasonably practicable that the Goods will be safe without risk to health at all times, when it is being installed, used, cleaned or maintained by a person at work and that all such manuals instructions or documents remain with the Goods

8.7 GENERAL
10.1 The Contract is personal to the Buyer which may not assign or dispose of any of its rights or obligations or otherwise delegate any of its obligations under the Contract without the written consent of the Company

10.2 The Company shall be entitled to assign its rights and obligations under the Contract to and sub-contract or otherwise delegate any of its obligations under the Contract

10.3 Any notice required or permitted to be given by either party to the other under these Conditions shall be in writing including a facsimile addressed to that party at a registered office of the Company or to such other address as may be the relevant time have been notified pursuant to this provision to the party giving the notice and shall be deemed to have been received by the party to whom it was addressed, if sent by facsimile, if sent by post, 24 hours after posting

10.4 No waiver by the Company of any breach of the Contract by the Buyer shall be considered as a waiver of any subsequent breach of the same or any other provision 10.5 If any provision of these Conditions is held to be invalid or unenforceable or incompetent authority to be invalid or unenforceable in whole or in part the validity of the other provisions of these Conditions and the remainder of the provision in question shall not be affected

10.6 The Contract and these Conditions shall be governed by the laws of England
10.7 The parties hereby submit to the non-exclusive jurisdiction of the English courts

10.8 The Buyer shall indemnify the Company for all costs and damages, including attorneys' fees, suffered by the Company as a result of the Buyer's actual or threatened breach of these terms and conditions

11. INFORMATION
The Company will provide the Buyer with information as to the proper safe use of the Goods and shall be responsible for all times and comply with the Company's instructions or other information relating to the use of the Goods

Specific product warranty terms are available on request.



THE FUTURE OF HEATING
IT'S ALL IN THE DETAILS...

www.stromltd.com
STROM LIMITED 2020

