

SUPPLIED COMPONENTS		#	DESCRIPTION	QTY
		1	MIDDLE / REAR ROOF BRACKET	6
		2	FRONT ROOF BRACKET	2
		3	P160 RUBBER PAD	8
		4	TOP HAT COVER	8
		5	TOP HAT	8
		6	ROOF BAR	4
SUPPLIED FIXING KIT		#	DESCRIPTION	QTY
		1	M6x25 HEX BOLT	14
		2	M6 SERRATED FLANGE NUT	16
		3	M6x16 COACH BOLT	16
		4	M6 SHAKEPROOF	14
		5	M6x20 WASHER	14
		6	RUBBER WASHER	14

TOOLS REQUIRED: 10mm SPANNER / RATCHET

This FITTING INSTRUCTION is the property of VAN GUARD ACCESSORIES LTD. and must not be used for manufacturing purposes, copied nor communicated in any way to third parties without written permission from VAN GUARD ACCESSORIES LTD.

IN8121_A - IW - 06/10/2014

Van Guard Accessories Ltd
Fair Oak Close, Exeter Airport Business Park,
Exeter, Devon, EX5 2UL
www.van-guard.co.uk

1 Remove roof plugs to reveal the vehicles fixing points.

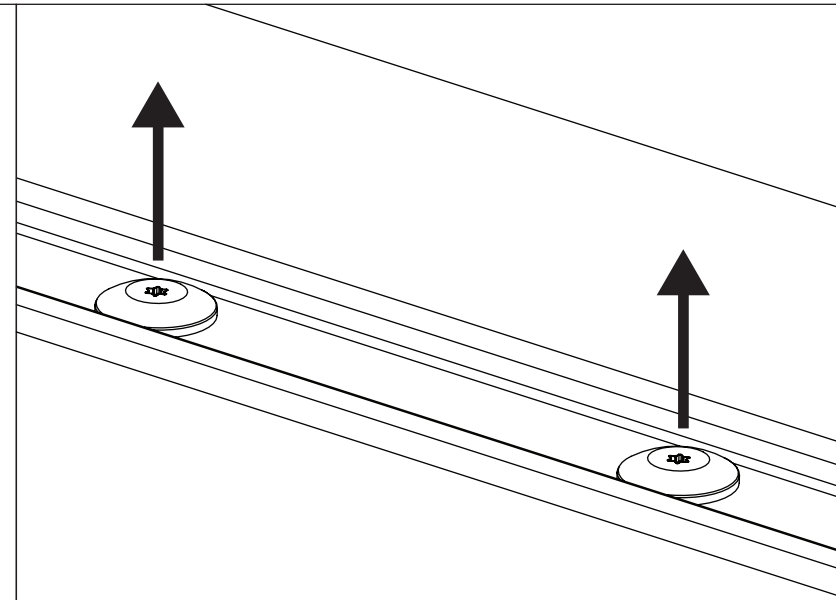
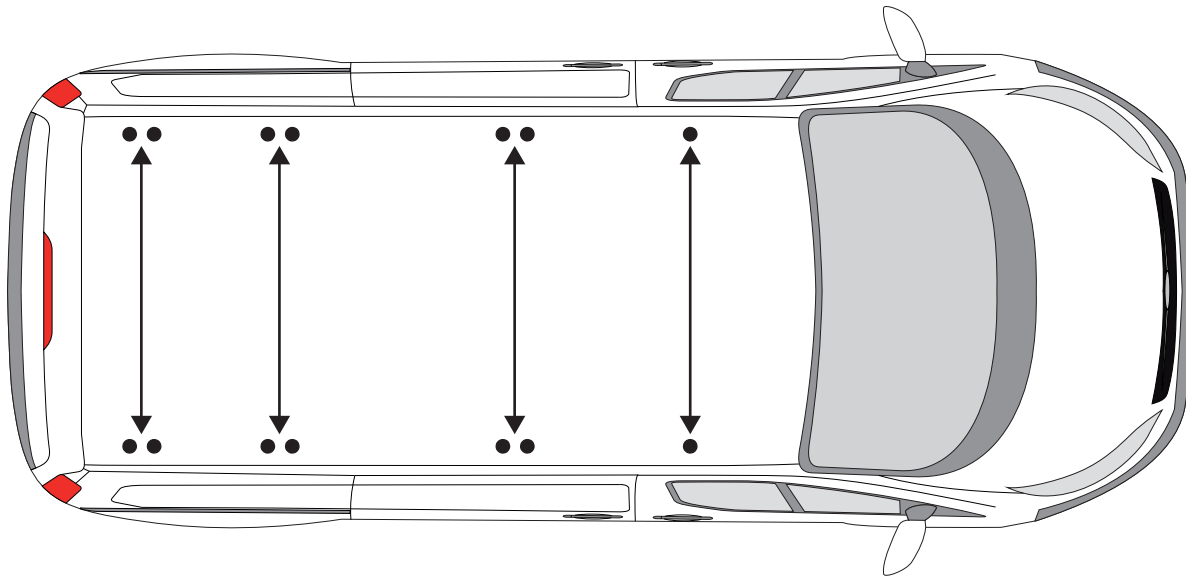

2 Stick rubber pads to the underside of all roof brackets.

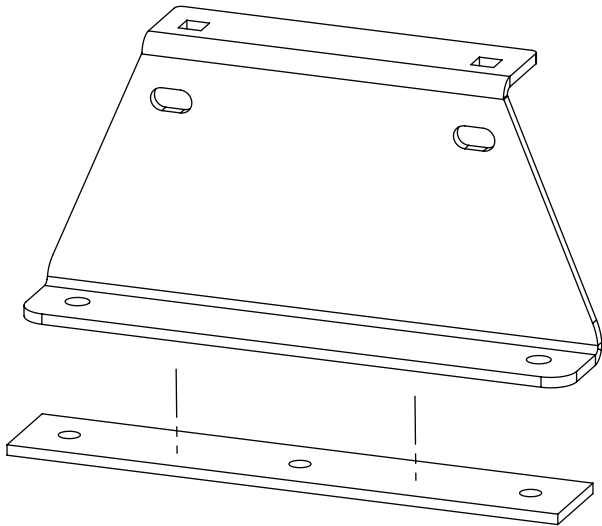

3 The roof brackets need to be positioned on the vehicle as shown below.

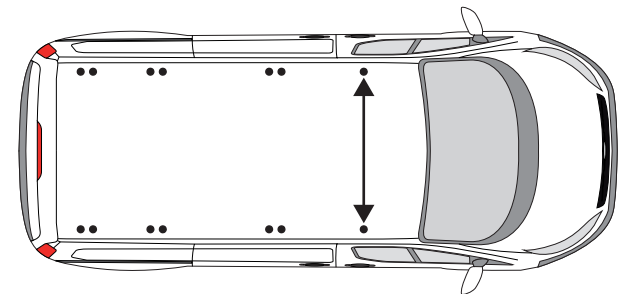
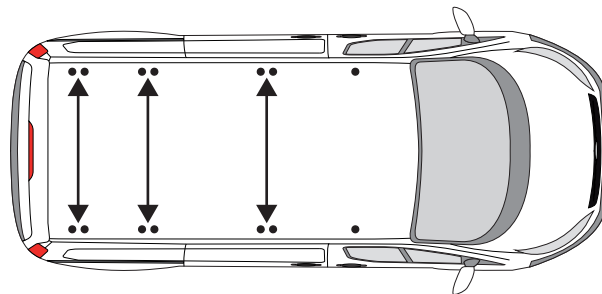
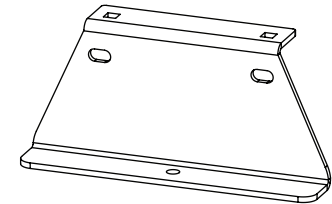
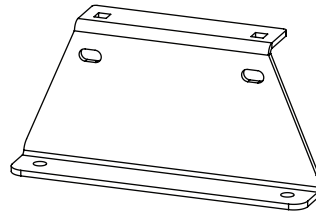

4 Secure roof brackets to the vehicles fixing points using M6x25 hex bolts, M6 shakeproofs, M6x20 washers & rubber washers. Ensure that the top hat flange is facing inwards.

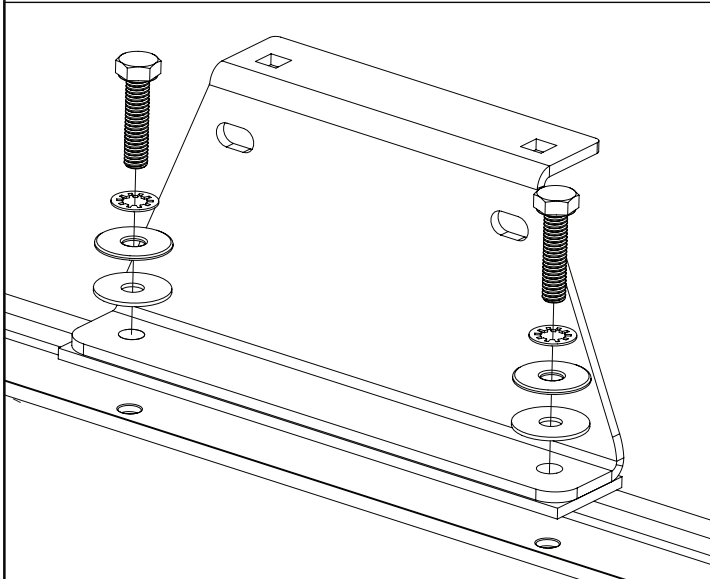

5 Place roof bars onto the roof brackets with the t-slot facing upwards, secure using top hat brackets, M6x16 coach bolts & M6 serrated nuts.

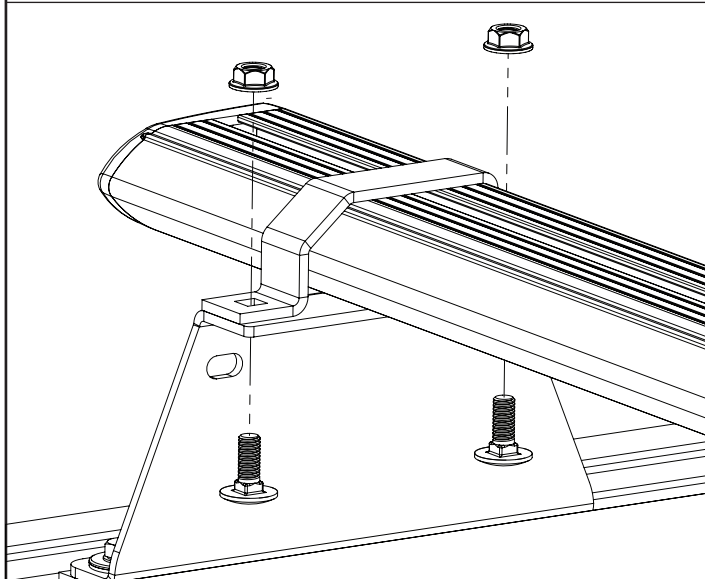

6 Flex the top hat covers over the top hat brackets into position as shown below. Ensure that the covers click into the front and rear of the top hat brackets.

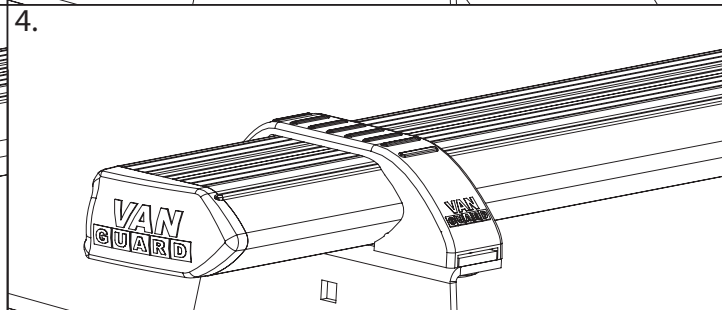
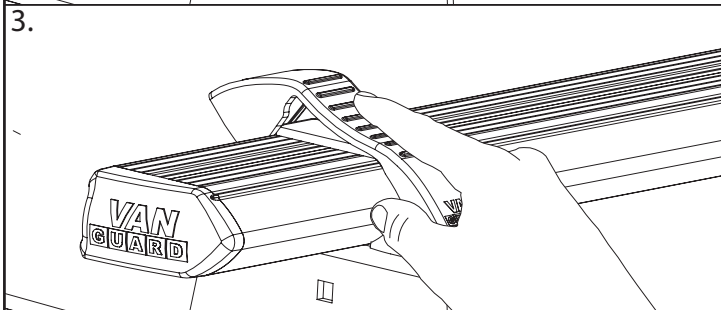
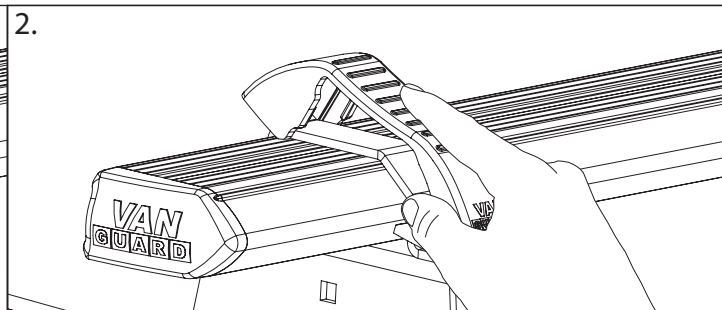
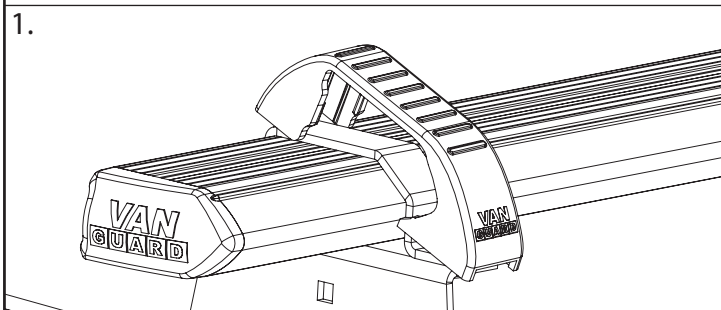

7 Once in position tighten all fixings to 8Nm. Periodically check all fixings.



**TIGHTEN
TO
8Nm**

NOTES:

Maximum load is 55kg per bar. Please check that the vehicle manufacturers load bearing capacity for the roof is not exceeded. (Refer to the vehicle handbook)

Periodically check all fixings.

Retain these instructions for future reference.