

VG313-2

2 Heavy duty aluminium roof bars - Ford Transit Courier 2014 onwards

SUPPLIED COMPONENTS

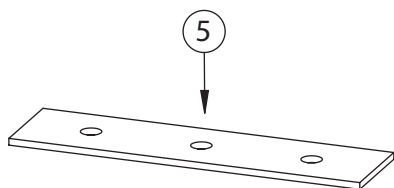
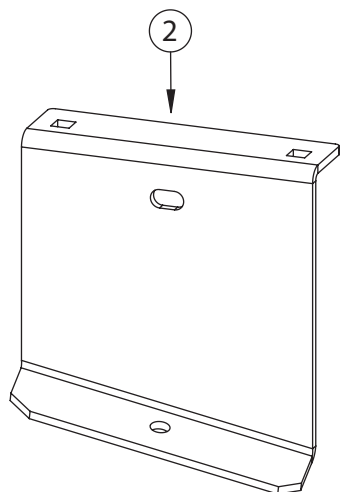
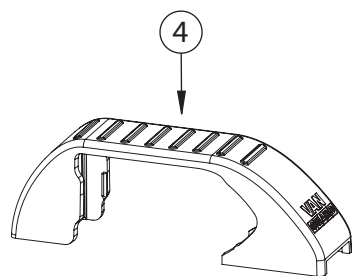
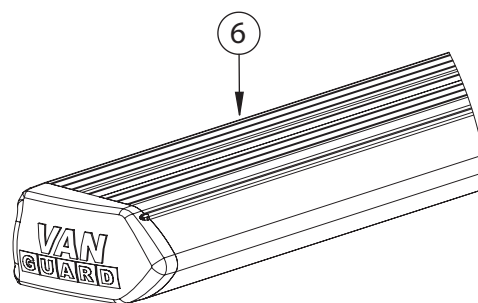
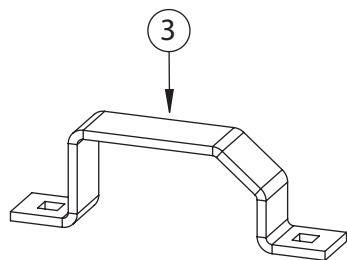
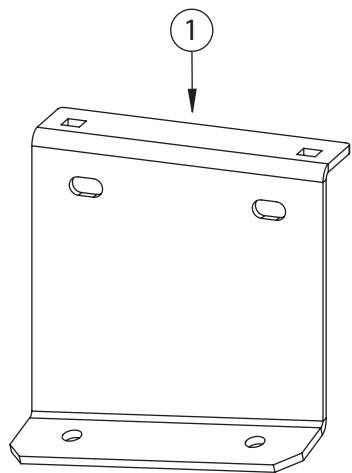

| # | DESCRIPTION | QTY |
|---|--------------------|-----|
| 1 | REAR ROOF BRACKET | 2 |
| 2 | FRONT ROOF BRACKET | 2 |
| 3 | TOP HAT | 4 |
| 4 | TOP HAT COVER | 4 |
| 5 | P105 RUBBER PAD | 4 |
| 6 | ROOF BAR | 2 |

SUPPLIED FIXING KIT

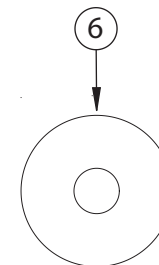
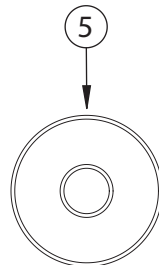
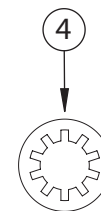
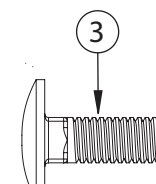
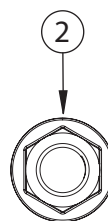
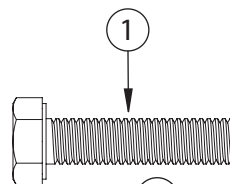

| # | DESCRIPTION | QTY |
|---|------------------------|-----|
| 1 | M6x25 HEX BOLT | 6 |
| 2 | M6 SERRATED FLANGE NUT | 8 |
| 3 | M6x16 COACH BOLT | 8 |
| 4 | M6 SHAKEPROOF | 6 |
| 5 | M6x20 WASHER | 6 |
| 6 | RUBBER WASHER | 6 |

TOOLS REQUIRED: 10mm SPANNER / RATCHET

This FITTING INSTRUCTION is the property of VAN GUARD ACCESSORIES LTD. and must not be used for manufacturing purposes, copied nor communicated in any way to third parties without written permission from VAN GUARD ACCESSORIES LTD.
IN8118_A - IW - 04/07/2014

Van Guard Accessories Ltd
Fair Oak Close, Exeter Airport Business Park,
Exeter, Devon, EX5 2UL
www.van-guard.co.uk

1

The roof brackets are handed to suit both sides of the vehicle and are angled to suit the slope of the roof. The brackets need to be positioned on the vehicle as shown below with the top hat flange facing inwards.

REAR (HANDED) - ILLUSTRATION SHOWS OFFSIDE

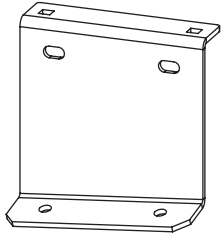

FRONT (HANDED) - ILLUSTRATION SHOWS OFFSIDE

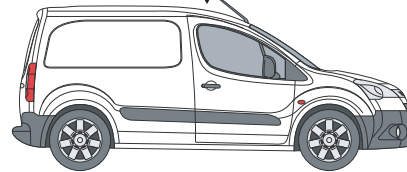
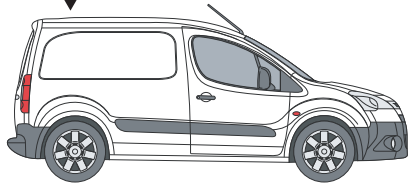
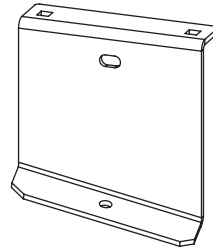
**2**

Stick rubber pads to the underside of all roof brackets.

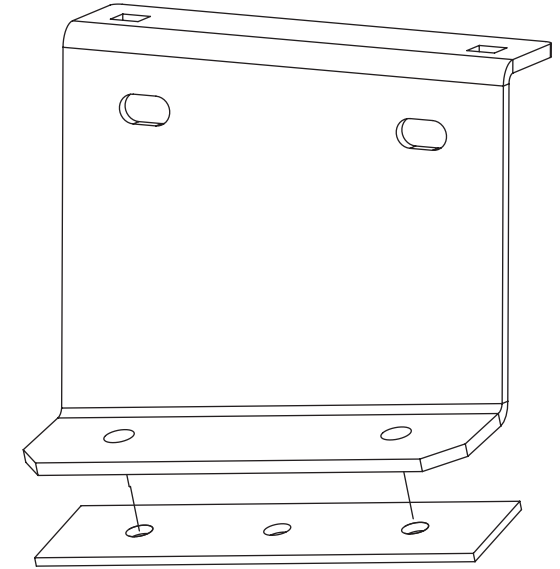
**3**

Remove roof plugs to reveal the vehicles fixing points. **Do not remove the front most roof plug as this is not required.**

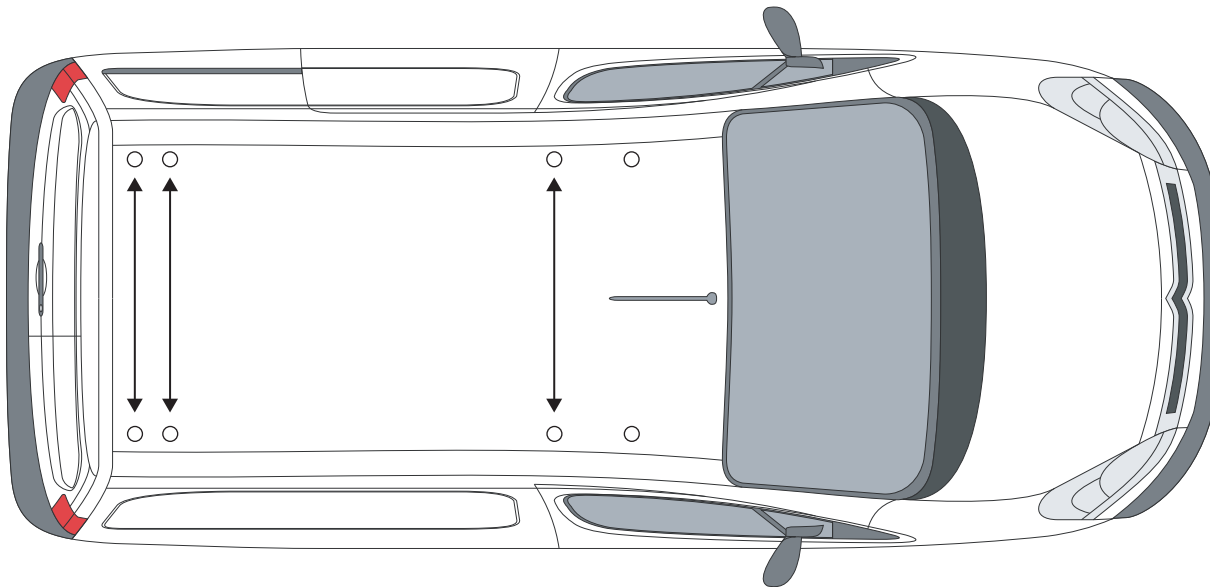
**4**

Secure roof brackets to the vehicles fixing points using M6x25 hex bolts, M6 shakeproofs, M6x20 washers & rubber washers. Ensure that the top hat flange is facing inwards.

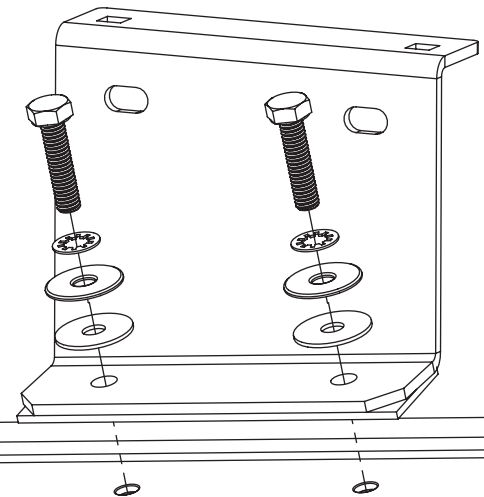

5 Place roof bars onto the roof brackets with the t-slot facing upwards, secure using top hat brackets, M6x16 coach bolts & M6 serrated nuts.

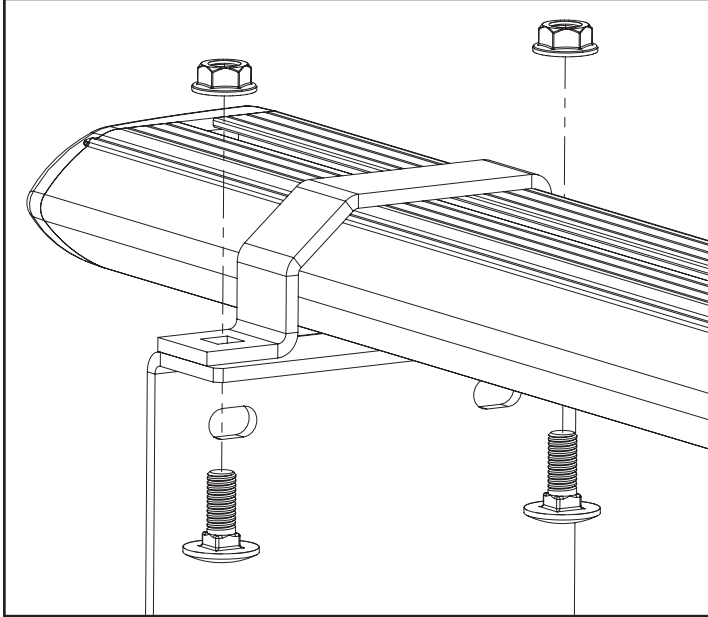

6 Flex the top hat covers over the top hat brackets into position as shown below. Ensure that the covers click into the front and rear of the top hat brackets.

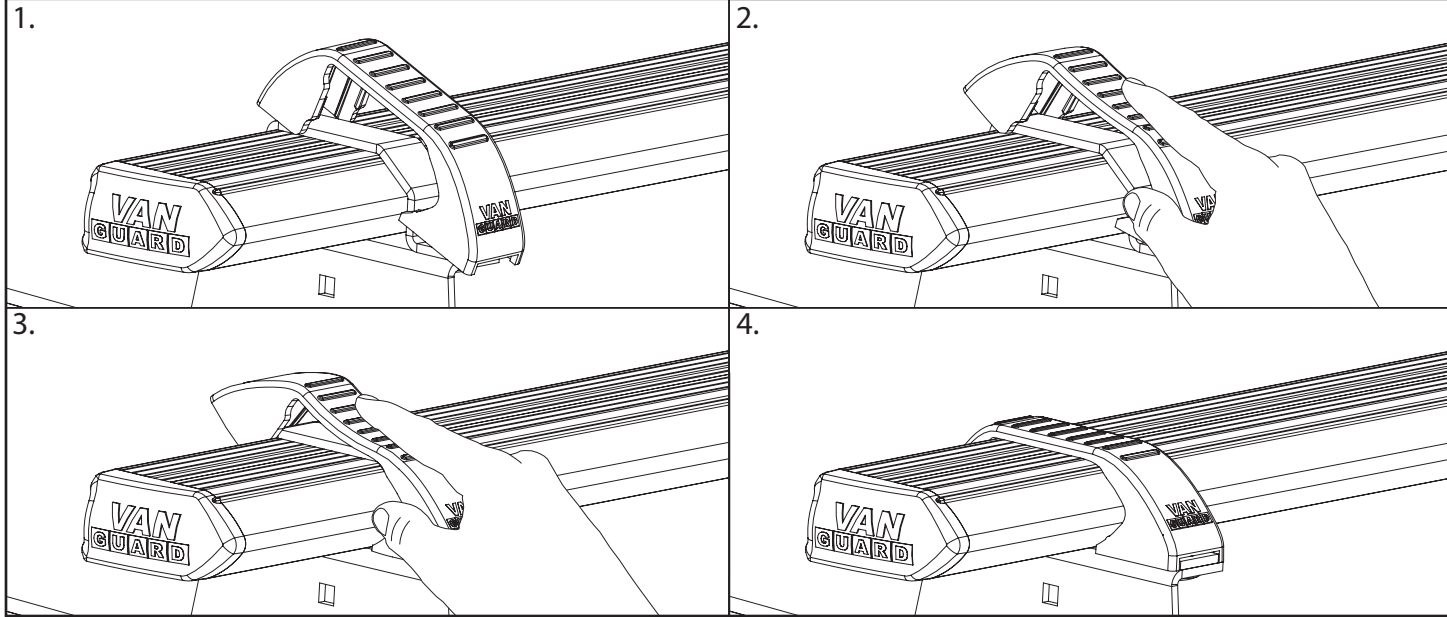

7 Once in position tighten all fixings to 8Nm. Periodically check all fixings.



**TIGHTEN
TO
8Nm**

NOTES:
Maximum load is 55kg per bar. Please check that the vehicle manufacturers load bearing capacity for the roof is not exceeded. (Refer to the vehicle handbook)
Periodically check all fixings.
Retain these instructions for future reference.

VAN GUARD