

# VG282-3

## 3 Heavy duty aluminium roof bars - Nissan NV200

### SUPPLIED COMPONENTS

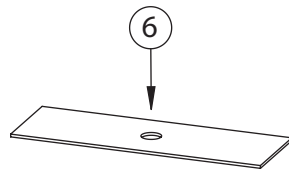
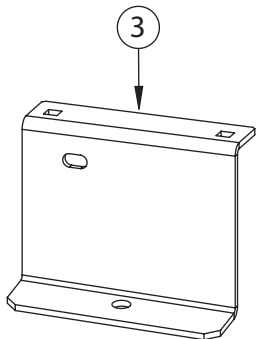
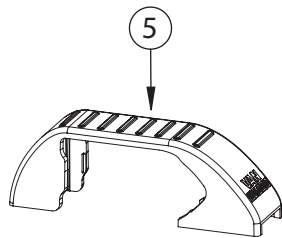
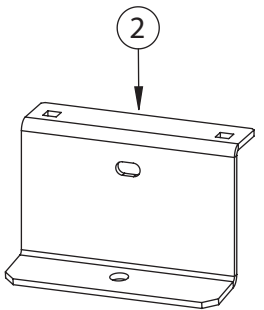
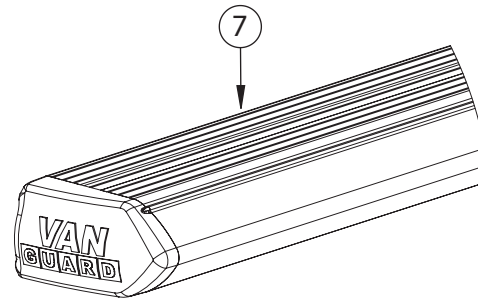
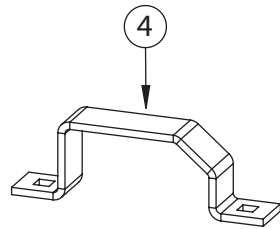
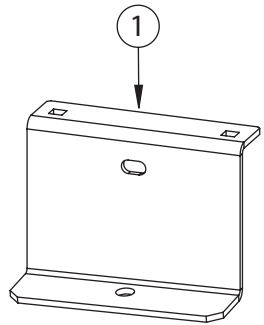

| # | DESCRIPTION         | QTY |
|---|---------------------|-----|
| 1 | REAR ROOF BRACKET   | 2   |
| 2 | MIDDLE ROOF BRACKET | 2   |
| 3 | FRONT ROOF BRACKET  | 2   |
| 4 | TOP HAT             | 6   |
| 5 | TOP HAT COVER       | 6   |
| 6 | H90 RUBBER PAD      | 6   |
| 7 | ROOF BAR            | 3   |

### SUPPLIED FIXING KIT

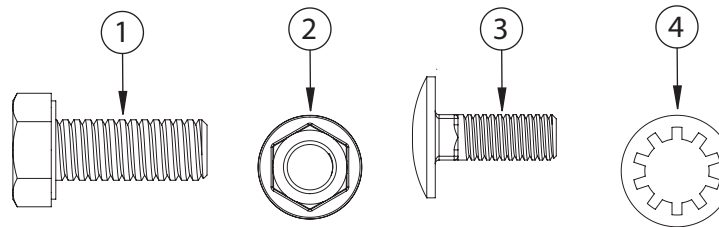

| # | DESCRIPTION            | QTY |
|---|------------------------|-----|
| 1 | M8x20 HEX BOLT         | 6   |
| 2 | M6 SERRATED FLANGE NUT | 12  |
| 3 | M6x16 COACH BOLT       | 12  |
| 4 | M8 SHAKEPROOF          | 6   |

TOOLS REQUIRED: 10mm & 13mm SPANNER / RATCHET

This FITTING INSTRUCTION is the property of VAN GUARD ACCESSORIES LTD. and must not be used for manufacturing purposes, copied nor communicated in any way to third parties without written permission from VAN GUARD ACCESSORIES LTD.  
IN8094\_A - IW - 03/05/2013

Van Guard Accessories Ltd  
Fair Oak Close, Exeter Airport Business Park,  
Exeter, Devon, EX5 2UL  
www.van-guard.co.uk

**1** The front and rear roof brackets are handed to suit both sides of the vehicle and are angled to suit the slope of the roof. The brackets need to be positioned on the vehicle as shown below with the top hat flange facing inwards.

REAR (HANDED) - ILLUSTRATION SHOWS OFFSIDE

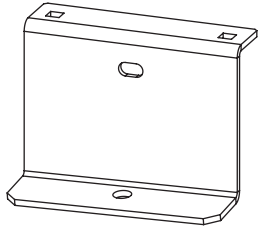

MIDDLE

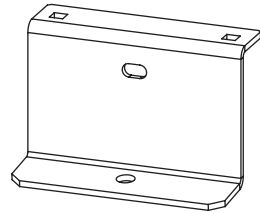

FRONT (HANDED) - ILLUSTRATION SHOWS OFFSIDE

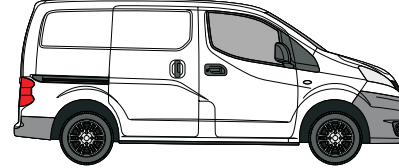
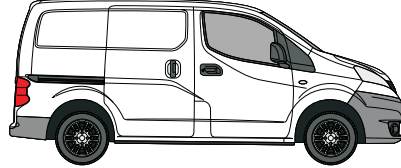
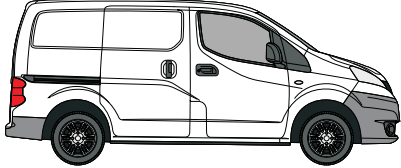
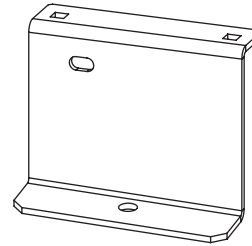

**2** Remove roof plugs to reveal the vehicles fixing points.

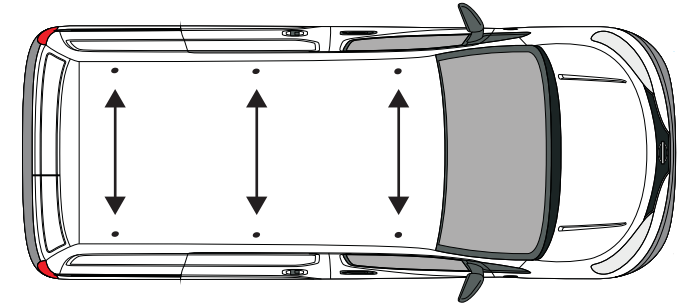

**3** Stick rubber pads to the underside of all roof brackets.

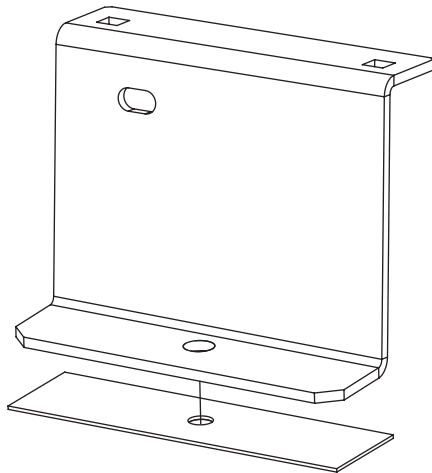

**4** Secure roof brackets to the vehicles fixing points using M8x20 hex bolts & M8 shakeproofs. Ensure that the top hat flange is facing inwards.

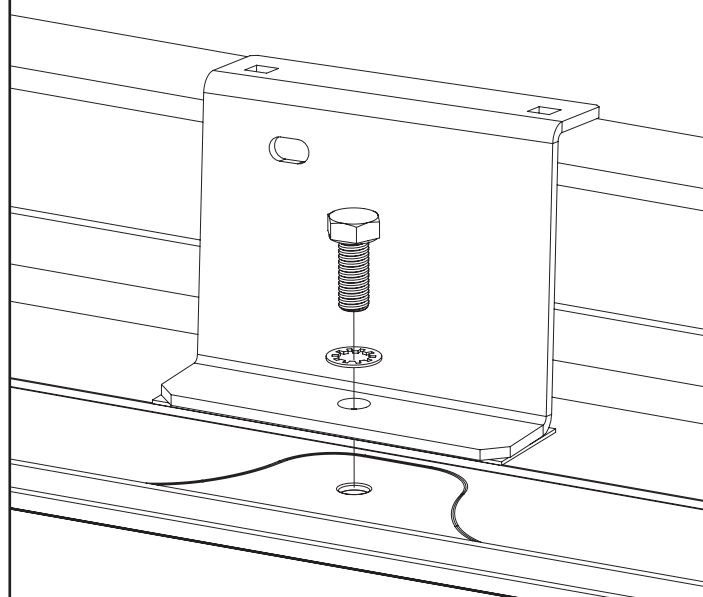

**5** Place roof bars onto the roof brackets with the t-slot facing upwards, secure using top hat brackets, M6x16 coach bolts & M6 serrated nuts.

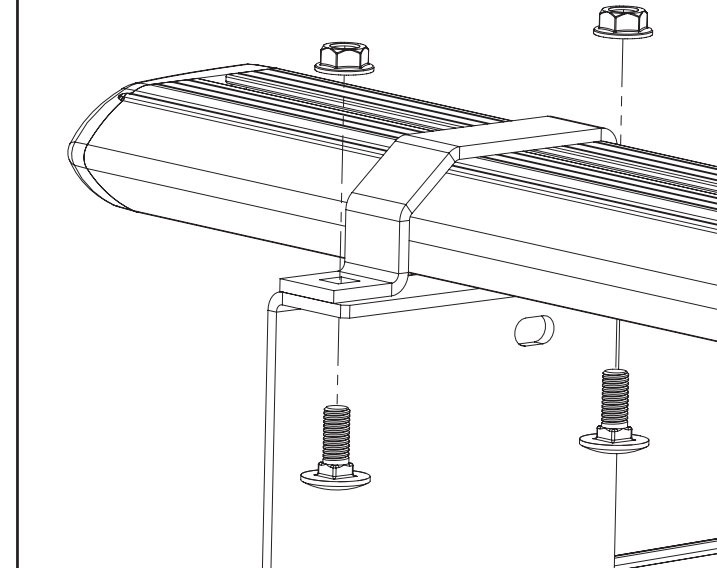

**6**

Flex the top hat covers over the top hat brackets into position as shown below. Ensure that the covers click into the front and rear of the top hat brackets.

1.

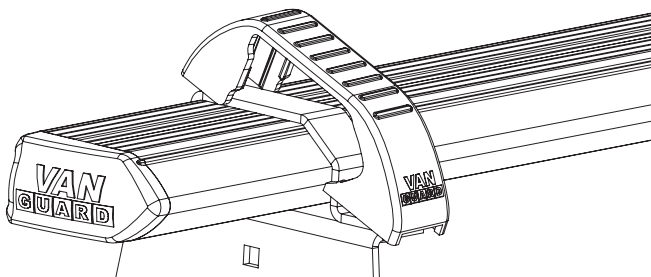

2.

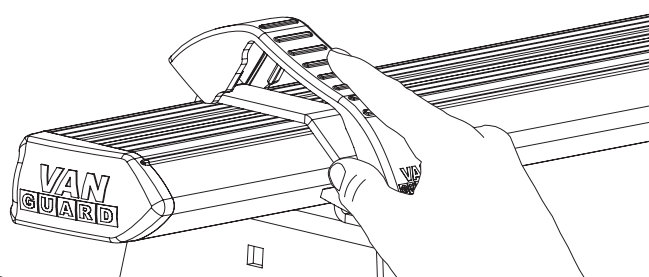

3.

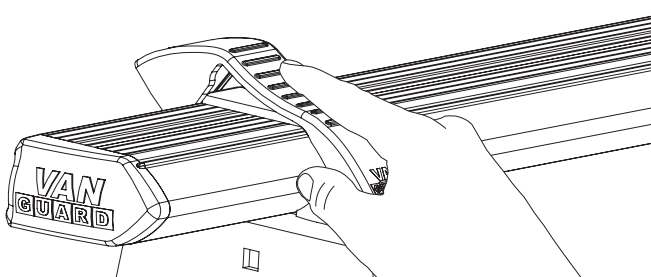

4.

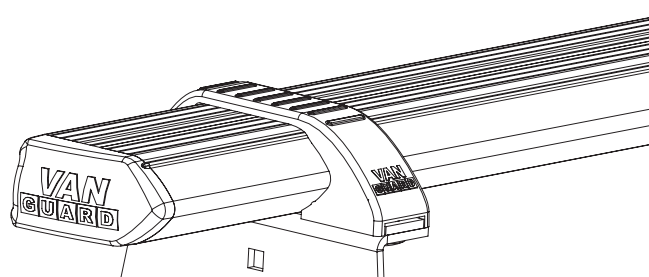
**7**

Once in position tighten all M6 fixings to 8Nm and all M8 fixings to 12Nm. Periodically check all fixings.



**TIGHTEN  
TO  
8/12Nm**

**NOTES:**

Maximum load is 55kg per bar. Please check that the vehicle manufacturers load bearing capacity for the roof is not exceeded. (Refer to the vehicle handbook)

Periodically check all fixings.

Retain these instructions for future reference.

# VAN

# GUARD