**Robert Bosch GmbH**

Power Tools Division
70764 Leinfelden-Echterdingen
GERMANY

www.bosch-pt.com

1 609 92A 0YJ (2015.03) 0 / 134 EURO



1 609 92A 0YJ

GHA FC2 Professional

BOSCH

de Originalbetriebsanleitung	pl Instrukcja oryginalna	sl Izvirna navodila
en Original instructions	cs Původní návod k používání	hr Originalne upute za rad
fr Notice originale	sk Pôvodný návod na použitie	et Algupärane kasutusjuhend
es Manual original	hu Eredeti használati utasítás	lv Instrukcijas oriģinālvalodā
pt Manual original	ru Оригинальное руководство по эксплуатации	lt Originali instrukcija
it Istruzioni originali	uk Оригінальна інструкція з експлуатації	ko 사용 설명서 원본
nl Oorspronkelijke gebruiksaanwijzing	kk Пайдалану нұсқаулығының түпнұсқасы	ar تعليمات التشغيل الأصلية
da Original brugsanvisning	ro Instrucțiuni originale	fa دفترچه راهنمای اصلی
sv Bruksanvisning i original	bg Оригинална инструкция	
no Original driftsinstruks	mk Оригинална упатство за работа	
fi Alkuperäiset ohjeet	sr Originalno uputstvo za rad	
el Πρωτότυπο οδηγιών χρήσης		
tr Orijinal işletme talimatı		





Deutsch	Seite	3
English	Page	7
Français	Page	11
Español	Página	15
Português	Página	19
Italiano	Pagina	23
Nederlands	Pagina	27
Dansk	Side	31
Svenska	Sida	34
Norsk	Side	38
Suomi	Sivu	41
Ελληνικά	Σελίδα	45
Türkçe	Sayfa	49
Polski	Strona	53
Česky	Strana	57
Slovensky	Strana	61
Magyar	Oldal	65
Русский	Страница	69
Українська	Сторінка	74
Қазақша	Бет	78
Română	Pagina	82
Български	Страница	85
Македонски	Страна	89
Srpski	Strana	93
Slovensko	Stran	97
Hrvatski	Stranica	101
Eesti	Lehekülg	104
Latviešu	Lappuse	108
Lietuviškai	Puslapis	112
한국어	페이지	116
عربي	صفحة	123
فارسی	صفحه	127



English

Read and strictly observe the safety warnings in the operating instructions of the cordless drill/driver.

Hammer Safety Warnings

- ▶ **Wear ear protectors.** Exposure to noise can cause hearing loss.
- ▶ **Use the auxiliary handle provided with the GHA FC2 hammer adapter.** Loss of control can cause personal injury.
- ▶ **Hold power tool by insulated gripping surfaces when performing an operation where the cutting accessory may contact hidden wiring.** Cutting accessory contacting a "live" wire may make exposed metal parts of the power tool "live" and could give the operator an electric shock.







Additional Safety and Working Instructions

- ▶ **Wear protective gloves.** The hammer adapter may become hot when operated for extended periods of time.
- ▶ **Before any work on the machine (e. g., maintenance, tool change, etc.) as well as during transport and storage, set the rotational direction switch to the centre position.** Unintentional actuation of the On/Off switch can lead to injuries.
- ▶ **Use appropriate detectors to determine if utility lines are hidden in the work area or call the local utility company for assistance.** Contact with electric lines can lead to fire and electric shock. Damaging a gas line can lead to explosion. Penetrating a water line causes property damage.
- ▶ **When working with the machine, always hold it firmly with both hands and provide for a secure stance.** The power tool is guided more secure with both hands.
- ▶ **Secure the workpiece.** A workpiece clamped with clamping devices or in a vice is held more secure than by hand.
- ▶ **Inserting SDS-plus Drilling Tools:** Check the latching by pulling the tool.
- ▶ **Replace a damaged dust protection cap immediately.** The dust protection cap largely prevents the penetration of drilling dust into the tool holder during operation. When inserting the tool, pay attention that the dust protection cap is not damaged.
- ▶ **Dusts from materials such as lead-containing coatings, some wood types, minerals and metal can be harmful to one's health and cause allergic reactions, lead to respiratory infections and/or cancer.** Materials containing asbestos may only be worked by specialists.
 - As far as possible, use a dust extraction system suitable for the material.
 - Provide for good ventilation of the working place.
 - It is recommended to wear a P2 filter-class respirator.
 Observe the relevant regulations in your country for the materials to be worked.



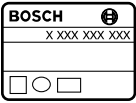













- ▶ **Prevent dust accumulation at the workplace.** Dusts can easily ignite.
- ▶ To save energy, only switch the power tool on when using it.
- ▶ **If the application tool should become blocked, switch the machine off. Loosen the application tool.**
- ▶ **When switching on with a blocked drilling tool, high torque reaction can occur.**
- ▶ **To make it easier to dismount the hammer adapter from the power tool, run the application tool 2 to 3 turns in left rotation (see figure 9, page 132).**
- ▶ **Always wait until the machine has come to a complete stop before placing it down.** The tool insert can jam and lead to loss of control over the power tool.
- ▶ **Avoid unintentional switching on. Ensure the On/Off switch is in the off position before inserting battery pack.** Carrying the power tool with your finger on the On/Off switch or inserting the battery pack into power tools that have the switch on invites accidents.

Symbols

The following symbols are important for reading and understanding the operating instructions. Please take note of the symbols and their meaning. The correct interpretation of the symbols will help you to use the machine in a better and safer manner.

Symbol	Meaning
	GSR 14,4 V-EC FC2/ GSR 18 V-EC FC2: Cordless Drill Driver Grey-marked area: Handle (insulated gripping surface)
	GHA FC2: Hammer adapter Grey-marked area: Handle (insulated gripping surface)
	Article number
	Read all safety warnings and all instructions
	Before any work on the machine itself, remove the battery from the power tool.
	Wear protective gloves

8 | English

Symbol	Meaning
	Always wear ear protection.
	Wear safety glasses/goggles
	Movement direction
	Reaction direction
	Next step of action
	Prohibited action
	Hammer Drilling
	Switching On
	Switching Off
	Low speed/impact rate
	High speed/impact rate
	Right/left rotation
	Tool holder
U	Rated voltage
E	Impact energy per stroke according to EPTA-Procedure 05/2009
n	Rated speed
n _s	Impact frequency at rated speed
	Concrete
∅	Drilling diameter, max.
	Weight according to EPTA-Procedure 01/2003
	Audible engagement (multiple)
*	Value dependent of the battery pack being used

Symbol	Meaning
L _{WA}	Sound power level
L _{PA}	Sound pressure level
a _h	Vibration total value
K	Uncertainty

Delivery Scope

Hammer adapter with auxiliary handle.
Application tools and other accessories shown or described are not part of the standard delivery scope.

A complete overview of accessories can be found in our accessories program.

Intended Use

The power tool (GSR 14,4 V-EC FC2/GSR 18 V-EC FC2 with GHA FC2 hammer adapter) is intended for hammer drilling in concrete, brick and stone.

The GHA FC2 hammer adapter must be used only with the GSR 14,4 V-EC FC2 and GSR 18 V-EC FC2 cordless drill/drivers.

Technical Data

The technical data of the machine are listed in the table on page 128.

Declaration of Conformity

We declare under our sole responsibility that the product described under "Technical Data" is in conformity with all relevant provisions of the directives 2009/125/EC (Regulation 1194/2012), 2011/65/EU, until 19 April 2016: 2004/108/EC, from 20 April 2016 on: 2014/30/EU, 2006/42/EC including their amendments and complies with the following standards: EN 60745-1, EN 60745-2-6.

Technical file (2006/42/EC) at:
Robert Bosch GmbH, PT/ETM9,
70764 Leinfelden-Echterdingen, GERMANY

Henk Becker Helmut Heinzlmann
Executive Vice President Head of Product Certification
Engineering PT/ETM9

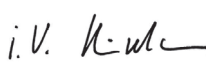
PPA.
 i.V. 

Robert Bosch GmbH, Power Tools Division
70764 Leinfelden-Echterdingen, GERMANY
Leinfelden, 17.12.2014

Noise/Vibration Information

The measured values of the machine are listed in the table on page 128.

Sound emission values determined according to EN 60745-2-6.

Vibration total values a_h (triax vector sum) and uncertainty K determined according to EN 60745-2-6.









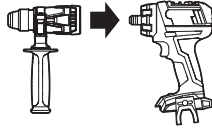

The vibration level given in this information sheet has been measured in accordance with a standardised test given in EN 60745 and may be used to compare one tool with another. It may be used for a preliminary assessment of exposure. The declared vibration emission level represents the main applications of the tool. However if the tool is used for different applications, with different accessories or insertion tools or is poorly maintained, the vibration emission may differ. This may significantly increase the exposure level over the total working period.

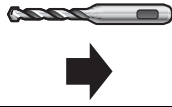
An estimation of the level of exposure to vibration should also take into account the times when the tool is switched off or when it is running but not actually doing the job. This may significantly reduce the exposure level over the total working period.

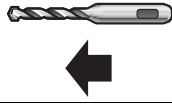
Identify additional safety measures to protect the operator from the effects of vibration such as: maintain the tool and the accessories, keep the hands warm, organisation of work patterns.

Mounting and Operation

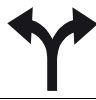
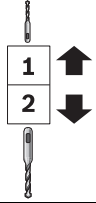
The following table indicates the action objectives for mounting and operation of the power tool. The instructions for each action objective are shown aside. Depending on the type of application, various instruction combinations are required. Observe the safety instructions.

Action	Figure	Please observe	Page
Mounting the hammer adapter			129
Inserting SDS-plus Drilling Tools		 	129
Removing SDS-plus Drilling Tools		  	129
Selecting the drilling position			130
Reversing the rotational direction			130
Gear selection, mechanical			131
Changing the position of the auxiliary handle			131

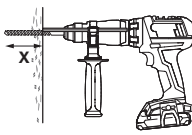
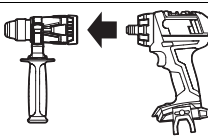
10 English			
Action	Figure	Please observe	Page
Adjusting the drilling depth X (The depth stop is available as an accessory.)		8	131
Dismounting the hammer adapter		9	132
Selecting Accessories	-		133

Maintenance and Cleaning

- **For safe and proper working, always keep the machine and ventilation slots clean.**

After each use, clean the tool, the GHA FC2 hammer adapter with tool holder, the ventilation slots of the power tool and the ventilation slots of the battery.

After-sales Service and Application Service

In all correspondence and spare parts order, please always include the 10-digit article number given on the type plate of the machine.

Our after-sales service responds to your questions concerning maintenance and repair of your product as well as spare parts. Exploded views and information on spare parts can also be found under:

www.bosch-pt.com

Bosch's application service team will gladly answer questions concerning our products and their accessories.

Great Britain

Robert Bosch Ltd. (B.S.C.)
P.O. Box 98
Broadwater Park
North Orbital Road
Denham
Uxbridge
UB 9 5HJ

At www.bosch-pt.co.uk you can order spare parts or arrange the collection of a product in need of servicing or repair.

Tel. Service: (0344) 7360109

E-Mail: boschservicecentre@bosch.com

Ireland

Origo Ltd.
Unit 23 Magna Drive
Magna Business Park
City West
Dublin 24
Tel. Service: (01) 4666700
Fax: (01) 4666888

Australia, New Zealand and Pacific Islands

Robert Bosch Australia Pty. Ltd.
Power Tools
Locked Bag 66
Clayton South VIC 3169
Customer Contact Center
Inside Australia:
Phone: (01300) 307044
Fax: (01300) 307045
Inside New Zealand:
Phone: (0800) 543353
Fax: (0800) 428570
Outside AU and NZ:
Phone: +61 3 95415555
www.bosch.com.au

Republic of South Africa

Customer service

Hotline: (011) 6519600

Gauteng – BSC Service Centre

35 Roper Street, New Centre
Johannesburg
Tel.: (011) 4939375
Fax: (011) 4930126
E-Mail: bsctools@icon.co.za

KZN – BSC Service Centre

Unit E, Almar Centre
143 Crompton Street
Pinetown
Tel.: (031) 7012120
Fax: (031) 7012446
E-Mail: bsc.dur@za.bosch.com

Western Cape – BSC Service Centre

Democracy Way, Prosperity Park
Milnerton
Tel.: (021) 5512577
Fax: (021) 5513223
E-Mail: bsc@zsd.co.za

Bosch Headquarters

Midrand, Gauteng
Tel.: (011) 6519600
Fax: (011) 6519880
E-Mail: rbsa-hq.pts@za.bosch.com

Disposal

The machine, accessories and packaging should be sorted for environmental-friendly recycling.

Do not dispose of power tools into household waste!

Only for EC countries:



According to the European Directive 2012/19/EU for Waste Electrical and Electronic Equipment and its implementation into national right, power tools that are no longer usable must be collected separately and disposed of in an environmentally correct manner.

Subject to change without notice.

Français

Lisez et observez strictement les consignes de sécurité de la notice d'utilisation de la perceuse-visseuse sans fil.

Avertissements de sécurité pour les marteaux

- ▶ **Portez des protections auditives.** L'exposition aux bruits peut provoquer une perte de l'audition.
- ▶ **Utilisez la poignée supplémentaire fournie avec l'embout perforateur GHA FC2.** Une perte de contrôle peut provoquer des blessures.
- ▶ **Tenir l'outil par les surfaces de préhension isolées, lors de la réalisation d'une opération au cours de laquelle l'organe de coupe peut entrer en contact avec un câble non apparent.** Le contact avec un fil « sous tension » peut également mettre « sous tension » les parties métalliques exposées de l'outil électrique et provoquer un choc électrique sur l'opérateur.

Autres instructions de sécurité et d'utilisation

- ▶ **Portez des gants de protection.** L'embout perforateur peut devenir très chaud lors d'une utilisation prolongée.
- ▶ **Avant d'effectuer des travaux sur l'outil électroportatif (p. ex. travaux d'entretien, changement d'outils, etc.) et avant de le transporter ou de le stocker, bloquez toujours l'interrupteur Marche/Arrêt en position médiane.** Il y a risque d'accidents lorsqu'on appuie par mégarde sur l'interrupteur Marche/Arrêt.
- ▶ **Utiliser des détecteurs appropriés afin de déceler des conduites cachées ou consulter les entreprises d'approvisionnement locales.** Un contact avec des conduites d'électricité peut provoquer un incendie ou un choc électrique. Un endommagement d'une conduite de gaz peut provoquer une explosion. La perforation d'une conduite d'eau provoque des dégâts matériels.

▶ **Toujours bien tenir l'outil électroportatif des deux mains et veiller à toujours garder une position de travail stable.** Avec les deux mains, l'outil électroportatif est guidé de manière plus sûre.

▶ **Bloquer la pièce à travailler.** Une pièce à travailler serrée par des dispositifs de serrage appropriés ou dans un étau est fixée de manière plus sûre que tenue dans les mains.

▶ **Mise en place d'un accessoire de travail SDS-plus :** Vérifiez si l'accessoire est bien encliqueté en tirant sur ce dernier.

▶ **Faire immédiatement remplacer un capot anti-poussière endommagé.** Le capot anti-poussière empêche dans une large mesure la pénétration de poussière dans le porte-outil pendant le fonctionnement de l'appareil. Lors du montage de l'outil, veillez à ne pas endommager le capot anti-poussière.

▶ **Les poussières de matières comme les peintures contenant du plomb, certaines essences de bois, certains minéraux ou métaux peuvent être nuisibles à la santé et peuvent causer des réactions allergiques, des maladies des voies respiratoires et/ou un cancer.** Les matériaux contenant de l'amiante ne doivent être travaillés que par des personnes qualifiées.

- Si possible, utilisez un dispositif d'aspiration des poussières approprié au matériau.
- Veillez à bien aérer la zone de travail.
- Il est recommandé de porter un masque respiratoire avec un niveau de filtration de classe P2.

Respectez les règlements spécifiques aux matériaux à traiter en vigueur dans votre pays.

▶ **Évitez toute accumulation de poussières à l'emplacement de travail.** Les poussières peuvent facilement s'enflammer.

▶ Afin d'économiser l'énergie, ne mettez l'outil électroportatif en marche que quand vous l'utilisez.

▶ **Au cas où l'outil de travail serait bloqué, arrêtez l'outil électroportatif. Desserrez l'outil de travail.**

▶ **Lorsqu'on met l'appareil en marche, l'outil de travail étant bloqué, il peut y avoir de fortes réactions.**

▶ **Pour faciliter le retrait de l'embout perforateur, faites tourner l'accessoire de travail de 2 à 3 tours en rotation gauche (voir fig. 9, page 132).**

▶ **Avant de déposer l'outil électroportatif, attendre que celui-ci soit complètement à l'arrêt.** L'outil risque de se coincer, ce qui entraînerait une perte de contrôle de l'outil électroportatif.

▶ **Éviter une mise en marche par mégarde. S'assurer que l'interrupteur Marche/Arrêt est effectivement en position d'arrêt avant de monter un accu.** Le fait de porter l'outil électroportatif en laissant le doigt sur l'interrupteur Marche/Arrêt ou de mettre en place l'accu dans l'outil électroportatif lorsque celui-ci est en marche peut entraîner des accidents.