

Manual

**mira**  
GO

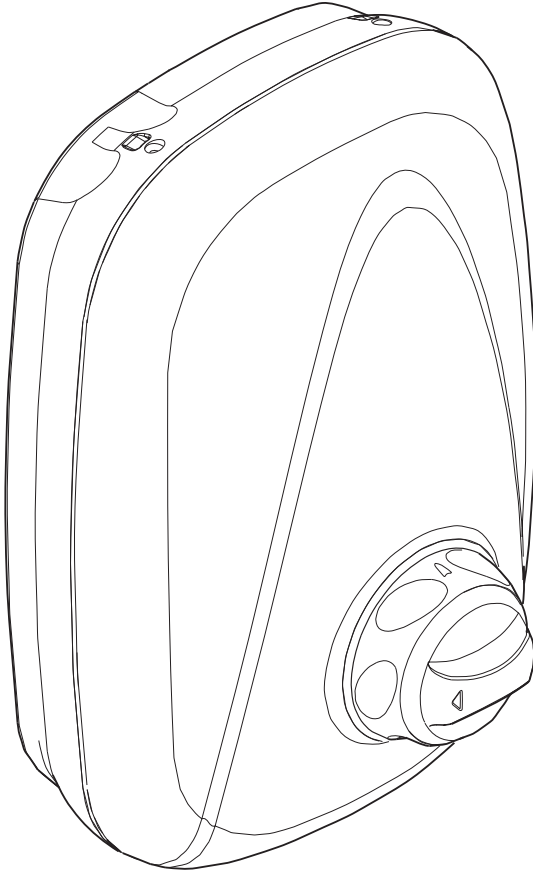

MANUAL

POWER SHOWER

Installation and User Guide

These instructions are to be left with the user

# CONTENTS

<b>Introduction</b> .....	<b>3</b>
Guarantee .....	3
Patents .....	3
<b>Important Safety Information</b> .....	<b>4</b>
Warning! .....	4
Caution! .....	6
<b>Pack Contents</b> .....	<b>7</b>
<b>Dimensions</b> .....	<b>8</b>
<b>Specifications</b> .....	<b>9</b>
<b>Installation Requirements</b> .....	<b>10</b>
<b>Installation</b> .....	<b>11</b>
General.....	11
Electrical.....	11
Plumbing .....	12
<b>Commissioning</b> .....	<b>19</b>
<b>Operation</b> .....	<b>20</b>
<b>Fault Diagnosis</b> .....	<b>21</b>
Fault Diagnosis - User Maintenance .....	21
Fault Diagnosis - Installer Maintenance .....	22
<b>Maintenance</b> .....	<b>24</b>
Cleaning .....	24
Handset.....	24
<b>Spare Parts</b> .....	<b>25</b>
<b>Accessories</b> .....	<b>26</b>
<b>Notes</b> .....	<b>27</b>
<b>Customer Service</b> .....	<b>28</b>

# INTRODUCTION

The Mira GO Manual Power Shower is an all-in-one power shower with an integral mains voltage pump, and separate controls for flow and temperature. It features a 15 mm dual entry push-fit manifold which supports various inlet supply configurations. The manifold includes inlet filters and check valves.

Designed to be surface mounted, the Mira GO Manual Power Shower comes complete with an adjustable spray handset with three settings, flexible hose, adjustable slider, sliding rail, soap tray and bracket.

## Guarantee

For domestic installations, Mira Showers guarantee the Mira GO Manual Power Shower against any defect in materials or workmanship for a period of **one** year from the date of purchase (shower fittings for one year).

For terms and conditions refer to the back cover of this guide.

Application	Valve Only
Domestic	✓
Light Commercial	✓
Heavy Commercial	x

## Patents

Patents	GB: 2 340 210
---------	---------------

If you experience any difficulty with the installation or operation of your new Power Shower, please refer to '**Fault Diagnosis**', before contacting Kohler Mira Ltd. Our telephone and fax numbers can be found in the back of this guide.

# IMPORTANT SAFETY INFORMATION

## Warning!

1. **Read all of these instructions and retain this guide for later use.**
2. **DO NOT CONNECT THE APPLIANCE TO A MAINS-FED WATER SUPPLY.** Such a connection will damage the Appliance, and is not covered under the manufacturer's guarantee.
3. **DO NOT** allow the Appliance to be run dry.
4. Products manufactured by us are safe and risk-free, provided that they are installed, used and maintained in good working order, in accordance with our instructions and recommendations.
5. **THIS APPLIANCE MUST BE EARTHED. MAKE SURE SUPPLEMENTARY BONDING COMPLIES WITH THE 'REQUIREMENTS FOR ELECTRICAL INSTALLATIONS' BS7671.**
6. This product is suitable for installation within Zone 1 and is rated IP X4.
7. This product is not suitable for areas with very high humidity (i.e steam rooms). Please consult your installer.
8. In accordance with 'The Plugs and Sockets etc. (Safety) Regulations' in force at the time of installation, this appliance is intended to be permanently connected to the fixed electrical wiring of the mains system.
9. Turn off the electrical and water supplies before commencing installation. The electricity must be turned off at the mains and the appropriate circuit fuse removed, if applicable.
10. Refer to the wiring diagram before making any electrical connections.
11. This appliance must be provided with means for disconnection that is incorporated into the fixed wiring in accordance with the relevant local wiring regulations
12. Make sure all electrical connections are tight, to prevent overheating.
13. **DO NOT** twist the individual cable cores of the live and neutral conductors, as this will prevent them from entering the terminal block.
14. Switch off the appliance at electrical isolating switch when not in use. This is for safety and is recommended with all electrical appliances.
15. **DO NOT** install the product in a position in which service access is restricted.
16. **DO NOT** install the appliance in a position where it may become frozen.
17. Make sure that any pipework that could become frozen is properly insulated.
18. **DO NOT** switch on if there is a possibility that the water in the appliance is frozen. The shower unit must not be fitted where it may be exposed to freezing conditions.
19. The water supplies to this product must be isolated if the product is not to be used for a long period of time. If the product or pipework is at risk of freezing during this period they should also be drained of water.
20. **DO NOT** fit any form of outlet flow control as the outlet acts as a vent for the tank body. Only Mira Showers recommended outlet fittings should be used.

21. If the shower is dismantled during installation or servicing then upon completion the product must be inspected to ensure there are no leaks.
22. **DO NOT** commission this appliance if water leaks from the unit.
23. **DO NOT** operate this appliance if water leaks from this appliance.
24. Only a competent person should remove the front cover. We recommend any maintenance work is carried out by a Mira Service Engineer or qualified tradesperson.
25. Mains connections are exposed when the cover is removed. Isolate the electrical and water supply before removing the cover.
26. If any of the following conditions occur, isolate the electricity and water supplies and refer to **To contact us**, on the back page of this guide.
  - If the cover is not correctly fitted and water has entered the appliance case
  - If the case is damaged
  - If the shower begins to make an odd noise, smell or smoke
  - If the shower shows signs of a distinct change in performance, indicating a need for maintenance
  - If the the shower is frozen
27. The shower head must be de-scaled regularly. Lack of regular shower head cleaning will lead to poor performance and cause early failure of the appliance. Refer to the Shower Fittings User Guide for more information.
28. Unless otherwise stated, electrical equipment such as extractor fans, pumps must not be connected via this product.
29. If pipework and/or electrical cables enter the shower from the rear through a hole in the wall . Provision must be made to prevent water ingress back into the wall structure.
30. Care is required when adjusting flow or temperature, make sure that the temperature has stabilised.
31. Rapid/Excessive movement of the flow and/or temperature control levers may result in momentary unstable blend temperatures.
32. **DO NOT** position the handset to spray water directly on to the appliance. Eg. When cleaning shower control.
33. Make sure that you fully understand how to operate this shower and make sure that it is properly maintained in accordance with the instructions given in this manual.
34. Having completed the installation, make sure that the user is familiar with the operation of the appliance.
35. When this appliance has reached the end of its serviceable life, it should be disposed of in a safe manner, in accordance with current local authority recycling, or waste disposal policy.
36. Moving parts are exposed when the cover is removed.

## **Caution!**

- 1. Read all of these instructions and retain this guide for later use.**
2. Make sure that this guide is left with the user. Pass on this guide in the event of change of ownership of the installation site.
3. Follow all warnings, cautions and instructions contained in this guide, and on or inside the shower.
4. Installation must be carried out in accordance with these instructions, and must be conducted by designated, qualified and competent personnel.
5. The electrical installation must comply to 'BS 7691 Requirements for Electrical Installations' (commonly referred to as the IEE Wiring Regulations Part 7, or any particular regulations and practices, specified by the local electricity supply company) in force at the time of installation. The installation should be carried out by an electrician or contractor who is registered, or is a member of, an association such as:
  - National Inspection Council for Electrical Installation and Contracting (NICEIC), throughout the UK
  - The Electrical Contractors Association (ECA), England and Wales
  - The Electrical Contractors Association of Scotland (ECAS)
6. The plumbing installation must comply with the requirements of UK Water Regulations/Bye-laws (Scotland), Building Regulations or any particular regulations and practices, specified by the local water company or water undertakers. The installation should be carried out by a plumber or contractor who is registered, or is a member of, an association such as:
  - Institute of Plumbing (IOP), throughout the UK
  - National Association of Plumbing, Heating and Mechanical Services Contractors (NAPH & MSC), England and Wales
  - Scottish and Northern Ireland Plumbing Employers' Federation (SNIPEF), Scotland and Northern Ireland
7. This appliance is not thermostatic and can produce scalding temperatures if not operated in accordance with the instructions given in this manual.
8. This appliance is not intended for use by persons (including children) with reduced physical, sensory or mental capabilities, or lack of experience and knowledge, unless they have been given supervision or instruction concerning the use of the appliance by a person responsible for their safety.
9. Children should be supervised to make sure that they do not play with the appliance.
10. Sunburn or skin conditions can increase your sensitivity to hot water.

# PACK CONTENTS

Tick the appropriate boxes to familiarise yourself with the part names and to confirm that the parts are included.

1 x Manual Power Shower

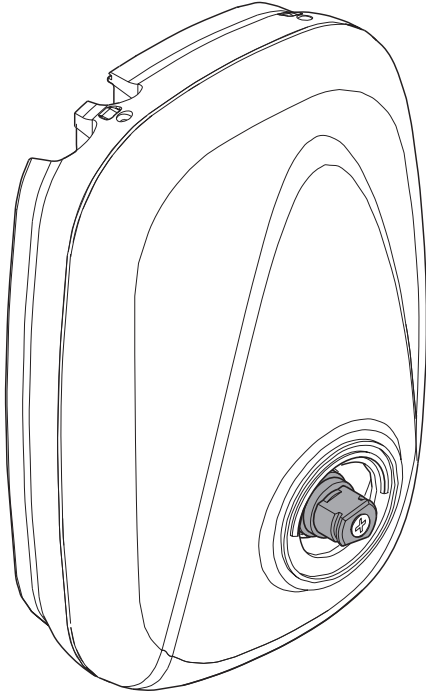

4 x Case Inserts

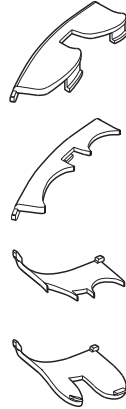

1 x Flow Control Knob

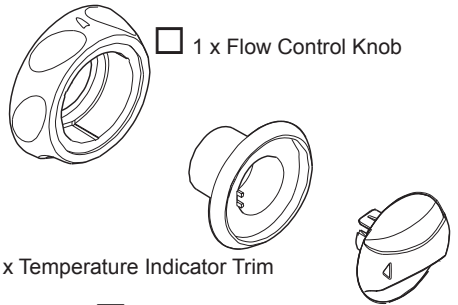

1 x Installation and User Guide

1 x Temperature Indicator Trim

1 x Guarantee Registration Document

1 x Temperature Control Knob

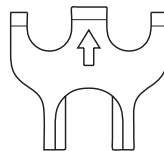

1 x Push-Fit Release Tool

# DIMENSIONS

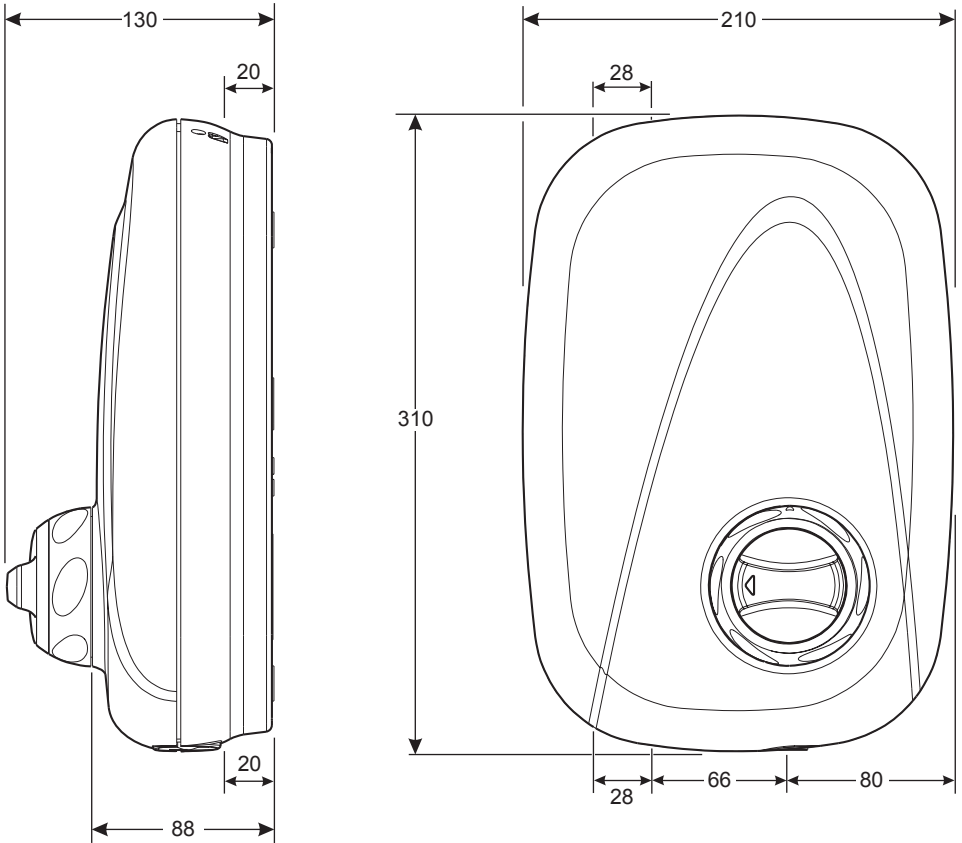

*All dimensions are nominal and in millimetres.*



# SPECIFICATIONS

## Electrical

**Power Supply:** 230 - 240 V at 50 Hz, fused at 3 Amps, via a double pole fused switch (not supplied) with a minimum contact separation of 3 mm for each contact.

**Electrical Connections:** Terminal block will accept cable up to 2.5 mm<sup>2</sup>. Minimum cable size (cross-sectional area) required under normal installation conditions is 1 mm<sup>2</sup>.

**Power Consumption:** 150 W maximum

## Plumbing Connections

**Inlet Connections:** 2 x 15 mm Push-fit manifold

**Outlet Connection:** 1/2" BSP male

## Operating Parameters

**Cold Water Temperature:** Maximum inlet temperature **30 °C**

**Hot Water Temperature:** Maximum inlet temperature **65 °C**

**Warning!** For safety reasons set the maximum temperature of the stored hot water to 65 °C or less. Such temperatures are considered sufficient to meet all normal requirements and will minimise the deposition of scale in hard water areas.

## Operating Pressure

Minimum maintained pressure: **1.0 kPa (0.01 bar)** or **100 mm** head of water

Maximum maintained pressure: **50 kPa (0.5 bar)**

Maximum static pressure: **100 kPa (1 bar)** or **10 m** head of water

**Duty Cycle:** The Mira GO Manual Power Shower pump is now continuously rated. The motor is fitted with a self-resetting thermal trip, designed to operate if motor temperatures become too high due to abnormally high supply voltages.

**Noise:** The acoustic noise from the pump motor has been reduced with the use of anti-vibration rubber feet and rubber wall plugs. The type of wall the Appliance is fixed to will also affect the perceived noise level, solid walls will provide a quieter operation.

## Standards

The Mira GO Manual Power Shower complies with all relevant directives for CE marking.

# INSTALLATION REQUIREMENTS

**Gravity Fed System** - The shower **MUST** be fed from a cold water cistern and hot water cylinder providing nominally equal pressure.

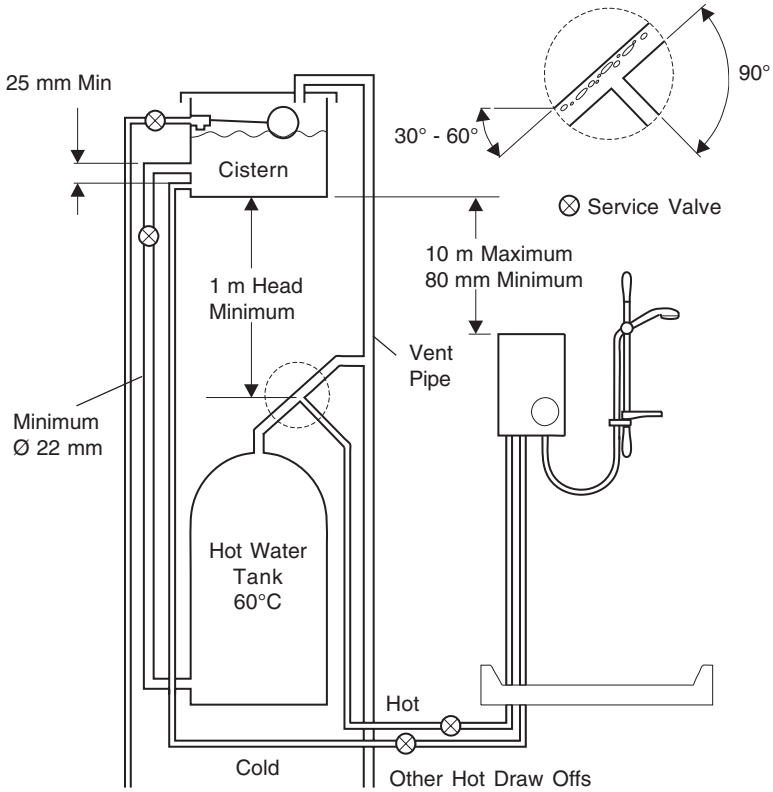

# INSTALLATION

## General

1. **Do not** take risks with plumbing or electrical equipment.
2. **Do not** install the shower unit in a position where it could become frozen.
3. Isolate electrical and water supplies before proceeding with the installation of the shower unit.
4. The shower unit **must** be fed from a cold water storage cistern and hot water cylinder with equal pressures. The shower unit **must not** be connected to a mains cold water supply, unvented high pressure systems or multi-point/combination gas water heaters.
5. The installation **must** be carried out by a competent installer.
6. Decide on a suitable position for the shower unit (minimum distance of 200 mm from the ceiling to allow for the fitting and removal of the cover). The position of the appliance and the shower fittings must provide a minimum gap of 25 mm between the spillover level of the shower tray/bath and the handset, to prevent backsiphonage.
7. Avoid layouts where the hose will be sharply kinked. This may reduce the life of the hose.
8. The shower unit is designed for surface mounting only and **must not** be recessed into any wall or cavity, or tiled up to, as this prevents air circulating to the rear of the unit.

## Electrical

1. The shower unit **must be earthed** by connecting the supply cable earth conductor to the earth terminal.  
**Supplementary bonding:** Within the bathroom or shower room, all accessible conductive parts of electrical equipment and extraneous conductive parts that are likely to introduce earth potential, must be electrically bonded to earth using a minimum cable size of 4.0 mm<sup>2</sup> if the cable is not mechanically protected (2.5 mm<sup>2</sup> if mechanically protected).
2. Power supply cable **must** have a minimum cross sectional area of 1 mm<sup>2</sup>.
3. Power supply **must** be 230-240 V at 50 Hz. The isolating switch **must** be double pole switched, fused at 3 Amps, with at least a 3 mm contact separation gap to each pole.
4. **Do not** turn the electrical supply on until all plumbing connections have been made and the shower unit has been commissioned as the unit **must not** be operated dry.
5. A 30 mA RCD (residual current device) **must** be fitted. This may be part of the consumer unit or a separate unit.
6. Fuses do not give personal protection against electric shock.

## Plumbing

1. A **minimum** storage capacity of cold water of 230 litres (50 gallons) is required to provide adequate showering time. Insufficient storage may result in the pump being run dry.
2. Layout and sizing of pipework **must** be such that nominally equal inlet supply pressures are achieved and the effects on the shower performance of other draw-offs are minimised. Make sure the shower unit is the first draw-off from the water supply.
3. Avoid routing the high level hot feed pipe upward to the same level as the cold tank e.g. into loft space, as air locks may result.
4. **Do not** solder supply pipework connected to the shower unit as heat transfer may damage plastic components.
5. **Do not** use jointing compounds on the shower unit joints, they may cause damage to the mechanism inside.
6. **Do not** insert fingers into the push fit connections.
7. The supply pipe ends **must be free from burrs**, as these will damage the push fit seals.
8. **Do not** use stainless steel piping for inlet pipework.
9. If plated tubing is used for inlet pipework remove the plating from the last 25 mm of the tube to make sure of a good seal.
10. 15 mm polythene plastic pipe suitable for hot water may be used to supply the shower unit, but internal pipe supports **must be** used.
11. Supplies **must be** thoroughly flushed to remove any debris before connecting the shower unit.
12. Fit non-restrictive (free-flowing) isolating valves in the inlet pipework to the appliance. Make sure isolating valves can be accessed easily.

**Warning!** Do not fix the shower unit to the wall until plumbing and electrical installations have been completed.

1. Decide on a suitable location for the shower unit **avoiding buried cables and pipes**. The unit should be positioned at a height convenient for all the family (at least 200 mm below the ceiling to allow for the fitting and removal of the unit cover).

The handset should spray away from the shower unit, either down the centre line of the bath or across the shower cubicle opening. Make sure that when the hose retaining ring is placed on the lowest position on the slide bar, the handset does not fall below the **minimum clearance gap** between the bath or shower tray spillover level of 25 mm.

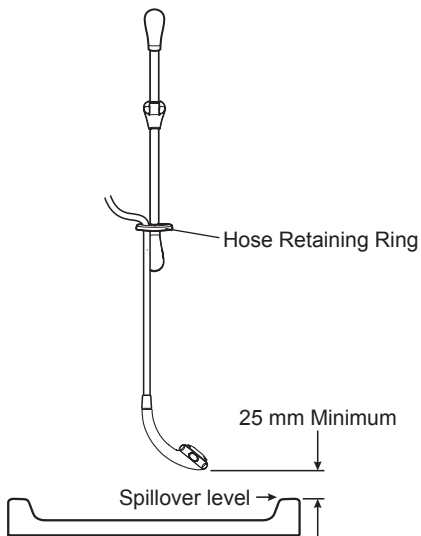

2. Hot and cold inlet supply connections are:

**Hot – Left      Cold – Right**

Run the hot and cold water supply pipes at 28 mm centres, make sure that the pipe ends project 30 mm into the inlet manifold.

**Warning!** Supply connections **must not** be connected in reverse.

**Caution! Do not** use stainless steel piping for inlet pipework.

**Caution!** If the pipework is chrome plated remove all traces of chrome from the connecting surfaces. If the chrome is not removed then the inlet manifold collets will **not** grip the supply pipe.

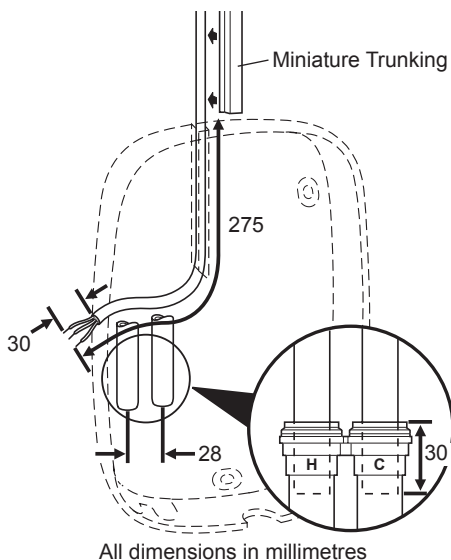

3. Make sure that the end of the supply pipework is cut squarely and is **free from burrs**, which will damage the inlet manifold seals.

Chamfer the end of the pipe to assist insertion into the fitting and prevent the 'O' seal tearing.

**Warning! Do not** insert fingers into the push-fit connectors as this can result in injury.

**Caution!** Thoroughly flush the incoming hot and cold water supply pipes to remove debris before connecting the shower unit.

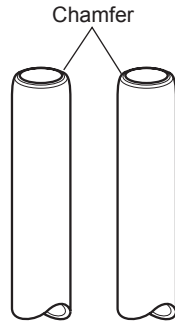

4. Run the electrical supply cable in surface mounted miniature trunking (not supplied). Allow sufficient cable to connect to the terminal block (approximately 275 mm). Strip back approximately 30 mm of outer cable insulation.

Trim the thinned section of the case covering the cable channel.

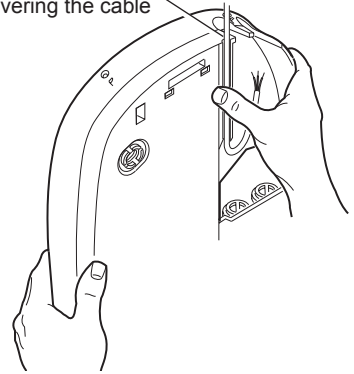

5. Loosen the three cover securing screws and remove the shower unit cover.

**Note!** The cover securing screws are captive and should **not** be unscrewed fully from the unit case.

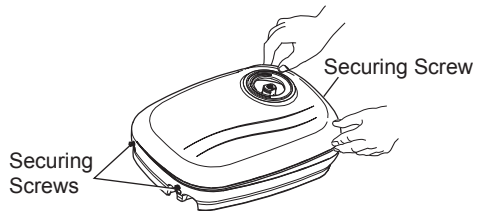

6. Insert the push-fit release tool between the flange of the blanking plug and the inlet manifold collet and lever the plugs outward. Whilst holding back on the collet, pull out the appropriate blanking plug by hand.

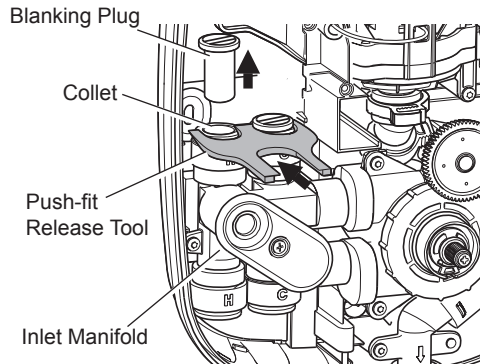

7. Temporarily locate the shower unit.

8. Position the shower unit on the wall and mark the three fixing points.

**Note!** Installers may wish to obtain alternative proprietary cavity fixings for dry lined, stud partition or dry partition wall structures.

9. Use the push-fit release tool to push the grey collars into the manifold to release the shower unit from the supply pipes.

**Warning!** Make sure there are no buried cables or pipes near the fixing points before drilling.

10. Drill 9.5 mm holes and fit the wall plugs supplied.

11. Cut away and trim the thinned section at the top or bottom of the case to allow the electrical supply cable to run down the rear of case.

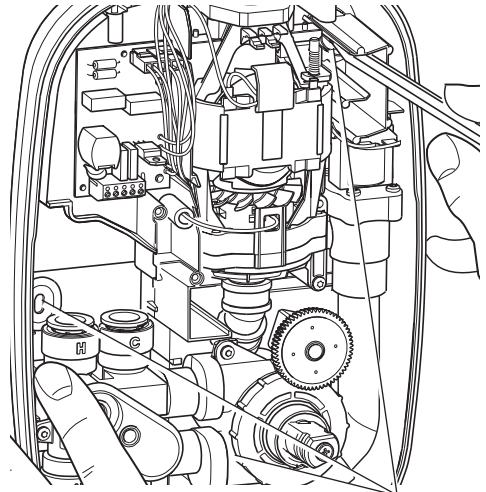

Fixing Points

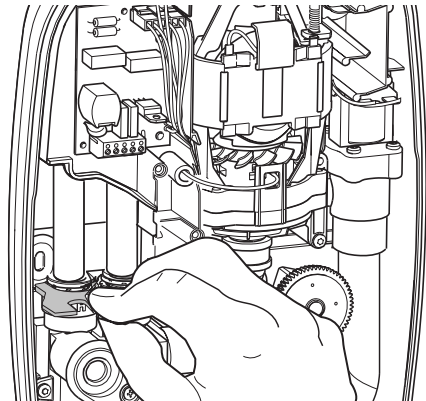

12. Fit the three rubber feet into the recesses in the rear of the case as shown. The feet will reduce the noise transmitted by the power shower through the wall.

**Warning!** Blanking plates should be fitted to stop water ingress into the inside of the unit.

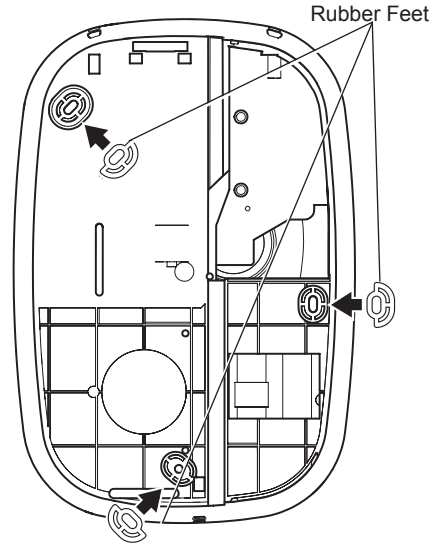

13. Fit the blanking plates to the unit case in the following manner.

For Top Inlet Pipework

Fit the half blanking plate to the top of the case.



Fit the full blanking plate to the bottom of the case.

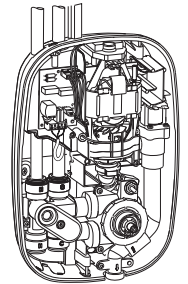

For Rear Inlet Pipework

Fit the full blanking plates to the top and bottom of the case.

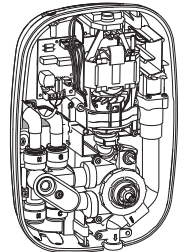

For Bottom Inlet Pipework

Fit the full blanking plate to the top of the case.



Fit the half blanking plate to the bottom of the case.

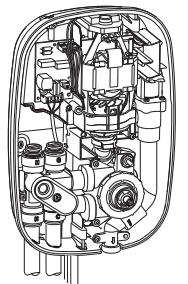



14. Locate the shower unit on the inlet supplies and push the inlet manifold onto the pipework until resistance is felt.

**DO NOT FORCE!**

**Note!** PTFE tape or liquid jointing compound must not be used and is **not** required to assist connection.

15. The inlet manifold collet and 'O' seals will seal automatically.

**Warning!** The shower unit **must** be fixed to the wall at all three fixing points. The fixing holes are elongated to assist in vertical and horizontal alignment.

16. Screw the shower unit to the wall using either the wall screws supplied or alternative fixings depending on the wall structure.

**Do not over tighten!**

Make sure that the electrical supply cable is correctly seated in the channel in the back of the case.

17. Connect the live, neutral and earth conductors of the electrical supply cable to the terminal block in the following manner.

L - Live terminal block

N - Neutral terminal block

⏚ - Earth terminal block

The earth supply cable must be sleeved and make sure that all the terminal connections are tight and that no insulation is pinched.

18. Make sure the flow control gear is set to the **OFF** position by turning the gear wheel **anticlockwise** until it stops. **DO NOT** force the gear wheel as damage will occur.

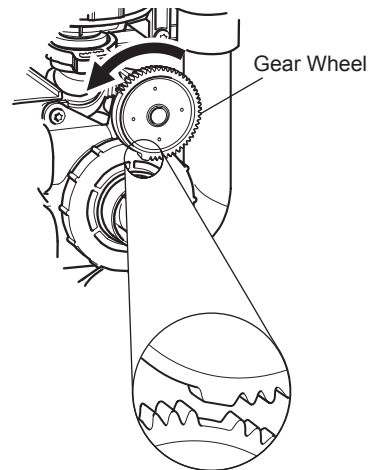
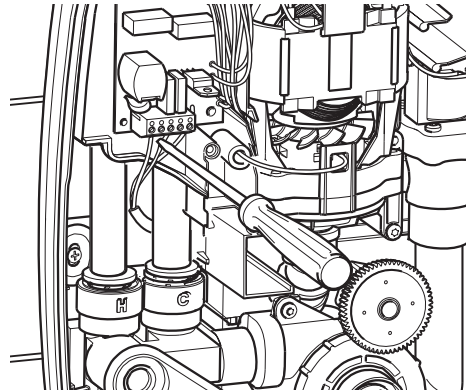
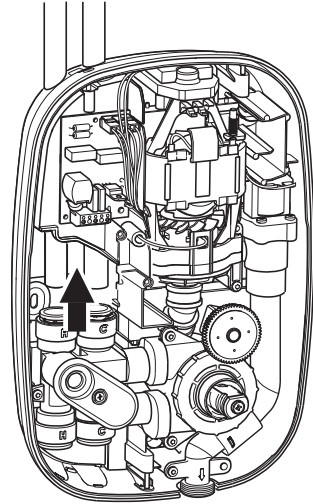

19. Refit the unit cover and secure with the three cover securing screws.

20. Insert the flow control knob in the OFF position.

21. Insert the temperature indicator trim and the inner temperature control knob.

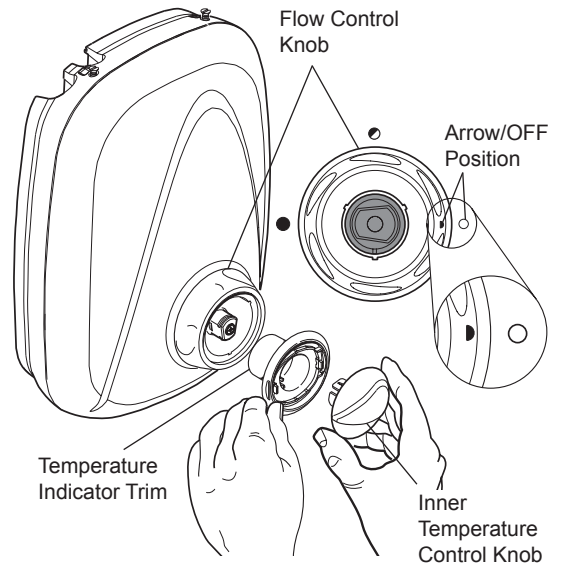
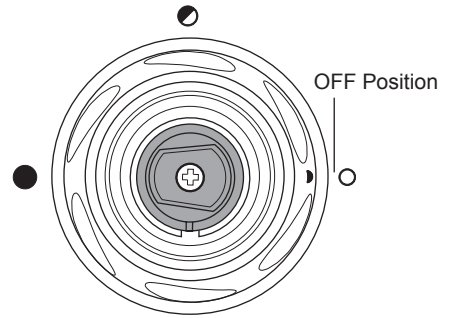

22. The power shower will now require commissioning, refer to **COMMISSIONING**.

23. Install the shower fittings, refer to the instruction manual supplied with the fittings.

# COMMISSIONING

The unit **must not** be run dry. Before proceeding any further with the installation the shower unit must be commissioned.

1. Connect the flexible hose to the outlet of the shower unit.

**Caution!** Do not over tighten.

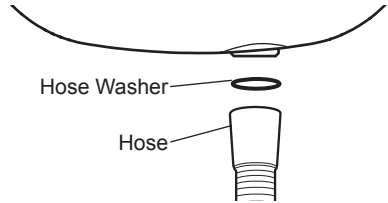

2. Turn on the water supplies and check for leaks.

3. Switch on the electrical supply.

4. Turn the outer flow control **anticlockwise** to full flow.

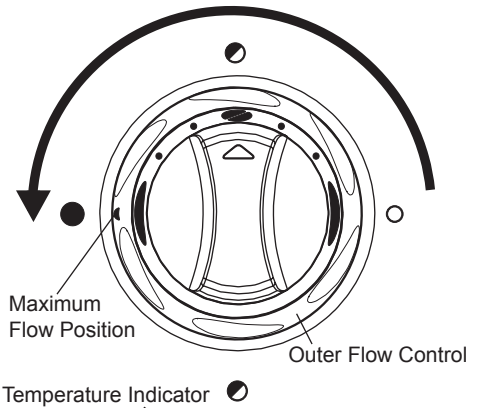

5. Rotate the inner temperature control anticlockwise to check the hot supply and clockwise to check the cold supply.

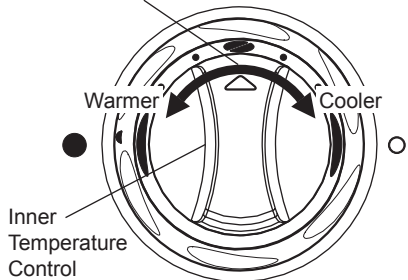

6. Turn the flow control **clockwise** to the **OFF** position.

7. The shower unit is now commissioned.

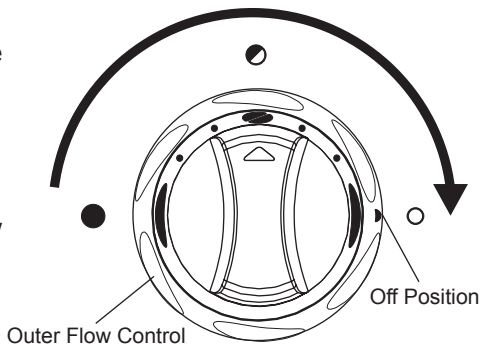

# OPERATION

**Warning!** The shower is a manual mixing shower which can select water temperatures from **FULL HOT** to **FULL COLD**. If the temperature control knob is turned anticlockwise fully the shower will deliver water at the same temperature as the stored hot water temperature (this will be the same temperature as the hot tap water temperature).

**Note!** The shower is a manual mixing shower. The showering temperature will change if the incoming water temperature changes. Therefore incoming water supply temperatures must remain constant if a stable showering temperature is to be achieved.

1. Turn the outer flow control knob until the desired flow of water is obtained. The flow of water will increase the further the control is turned **anticlockwise**.

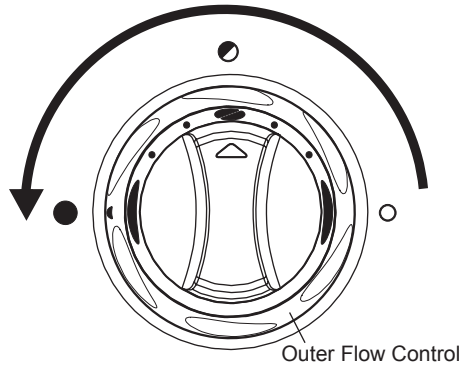

2. Turn the inner temperature control knob anticlockwise for warmer water and clockwise for cooler water.

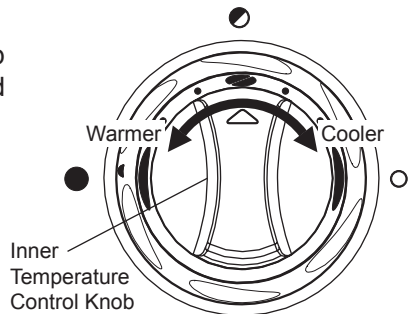

3. Turn the outer flow control knob fully **clockwise** to stop the flow of water.

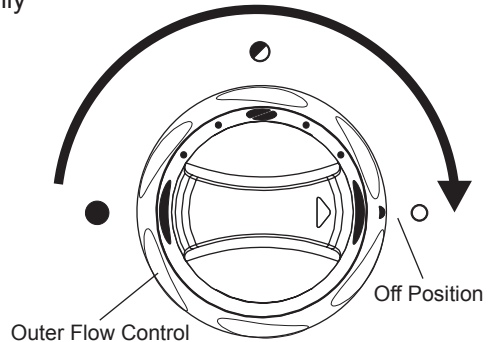

# FAULT DIAGNOSIS

## Fault Diagnosis - User Maintenance

The appliance is fully performance tested after assembly. Providing it has been correctly installed and is operated as advised, difficulties should not arise. In the unlikely event that you experience problems with your appliance then the following procedure will enable you to undertake basic fault finding before contacting the person responsible for installing your shower.

Malfunction	Cause	Remedy
The shower temperature is too cold.	The hot water cylinder temperature is less than 12 °C above the shower temperature.	Adjust the cylinder temperature. <b>Note!</b> It is recommended that stored water temperatures does not exceed <b>65 °C</b> .
The blend temperature is unstable.	The spray plate is blocked.  The inlet filters are blocked.  The isolating valve is partially closed.  Faulty plumbing system.	Clean the spray plate. Refer to the instruction manual supplied with the <b>shower fittings</b> .  Contact your installer.  Open the isolating valve.  Contact your installer.
The pump does not operate.	Electrical supply failure.  PCB failure.  Potentiometer failure.  The motor overheated and the thermal switch operated.	Contact your installer.  Contact your installer.  Contact your installer.  If the thermal switch operates repeatedly, contact customer service for further advice.
Low or no water flow.	Isolating valves are closed.  Inlet filters blocked.  Check the isolating valves are fitted incorrectly.  The appliance is sited above cold water storage cistern.    Faulty plumbing system (airlock).	Open the isolating valves.  Contact your installer.  Contact your installer.    The appliance is not suitable for negative head installations.  Refer to <b>INSTALLATION REQUIREMENTS</b> .  Contact your installer.

## Fault Diagnosis - Installer Maintenance

The Manual Power Shower is one part of an entire plumbing system. The fitting of a pump places additional requirements on the plumbing system. Some systems may require plumbing modifications to allow them to cope with higher flow rates.

Providing the Manual Power Shower has been correctly installed and is operated as advised, difficulties should not arise. Fault diagnosis and maintenance must be carried out by a competent person for whom the fault diagnosis table is provided.

In the event of any of the following tests failing, re-check as appropriate before contacting the Customer Support Department, (refer to the **Back Cover**).

<b>Malfunction</b>	<b>Cause</b>	<b>Remedy</b>
The shower runs for a short time (30-60 seconds) then the flow reduces, splutters or stops. Aggravated when other hot taps are in use. Less evident on full cold.	Air is being sucked down the vent pipe, as the hot take off to the shower is too high up the pipe.	Refer to the plumbing system diagram in <b>INSTALLATION REQUIREMENTS</b> for the correct connection method. <b>Note</b> the 1 metre hot takeoff dimension. Consider increasing the cold feed pipe to the cylinder to 28 mm diameter.
The shower runs cool after a short time (1-2 minutes) then flow splutters.	Air entering the hot pipework.	Refer to the plumbing system diagram in <b>INSTALLATION REQUIREMENTS</b> for the correct connection method.
Flow of water virtually stops and surges ON/OFF after a few minutes.	Insufficient storage of cold water in cistern (230 litres recommended).	Increase storage size of the cold water cistern.
The shower runs cold after 5-10 minutes.	Insufficient storage of hot water in cylinder.	Increase the storage size of the hot water cylinder.
The shower temperature is affected by the use of an adjacent hot/cold tap.	Insufficiently sized pipework for both systems to be used together.	Increase the pipe sizes or separately feed the shower. Refer to the plumbing system diagram in <b>INSTALLATION REQUIREMENTS</b> .

Malfunction	Cause	Remedy
Maximum shower temperature too cold.	Hot water cylinder temperature too low.	Adjust cylinder temperature. <b>Note!</b> The stored water temperature must not exceed <b>65 °C</b> .
The blend temperature unstable.	The spray plate is blocked.  The inlet filters are blocked.  The isolating valve is partially closed.	Clean the spray plate. Refer to the supplied <b>shower fittings manual</b> .  Clean the inlet filters.  Open the isolating valve.
The shower head is dripping.	The solenoid valve is faulty.	Renew the solenoid valve assembly.
The pump does not operate.	Electrical supply failure. PCB failure. Potentiometer failure.  The motor overheated and the thermal switch operated.	Check the power supply. Renew the PCB. Renew the harness assembly.  If the thermal switch operates repeatedly, contact customer services for further advice.
The pump does not stop or change speed when the flow knob is turned.	Potentiometer failure.  PCB failure.	Renew the harness assembly.  Renew the PCB.
Low or no water flow.	Isolating valves closed. Inlet filters blocked. Appliance sited above cold water storage cistern.  Plumbing system fault (airlock). Blocked spray plate.	Open the isolating valves. Clean the inlet filters.  The appliance is not suitable for negative head installations. Refer to <b>INSTALLATION REQUIREMENTS</b> .  Reroute the pipework to avoid airlock.  Clean the spray plate. Refer to the supplied <b>shower fittings manual</b> .

# MAINTENANCE

**Warning!** There are no user serviceable components beneath the cover of the appliance. Only a competent tradesperson should remove the cover.

Before removing the cover the electricity supply **must** be turned off at the mains and, if applicable, the appropriate circuit fuse removed. Mains electrical connections are exposed when the cover is removed.

Before replacing any parts make sure that the underlying cause of the malfunction has been resolved.

## **Cleaning**

Many household cleaners contain abrasives and chemical substances, and should not be used for cleaning plated or plastic fittings. These finishes should be cleaned with a mild washing up detergent or soap solution, and then wiped dry using a soft cloth.

## **Handset**

Poor shower performance can be avoided by regular cleaning of the handset. Use your thumb or soft cloth to wipe the rubber nozzles. The handset must also be descaled regularly.



# SPARE PARTS

- 147.67 Check Valve Pack
- 453.02 Cartridge - Manual
- 453.03 Motor Pump Assembly - components identified 'A'
- 453.07 Inlet Manifold Assembly - components identified 'B'
- 453.08 PCB Assembly - Power
- 453.12 Harness Assembly - Concentric - components identified 'C'
- 453.13 Solenoid Valve Assembly - components identified 'D'
- 453.14 Filter/Cap Assembly
- 453.15 Seal Pack - components identified 'E'
- 453.22 Stud Wall Fixing Kit (Push-fit Release Tool, 3 x Fixing Screws, 3 x Rubber Wall Plugs) - components identified 'H'
- 453.23 Mixer Valve Body - components identified 'F'
- 453.24 Inserts/Rubber Feet Pack - Power - components identified 'G'
- 453.28 Outlet Elbow Assembly
- 1532.333 Control Knob Assembly
- 1532.334 Cover

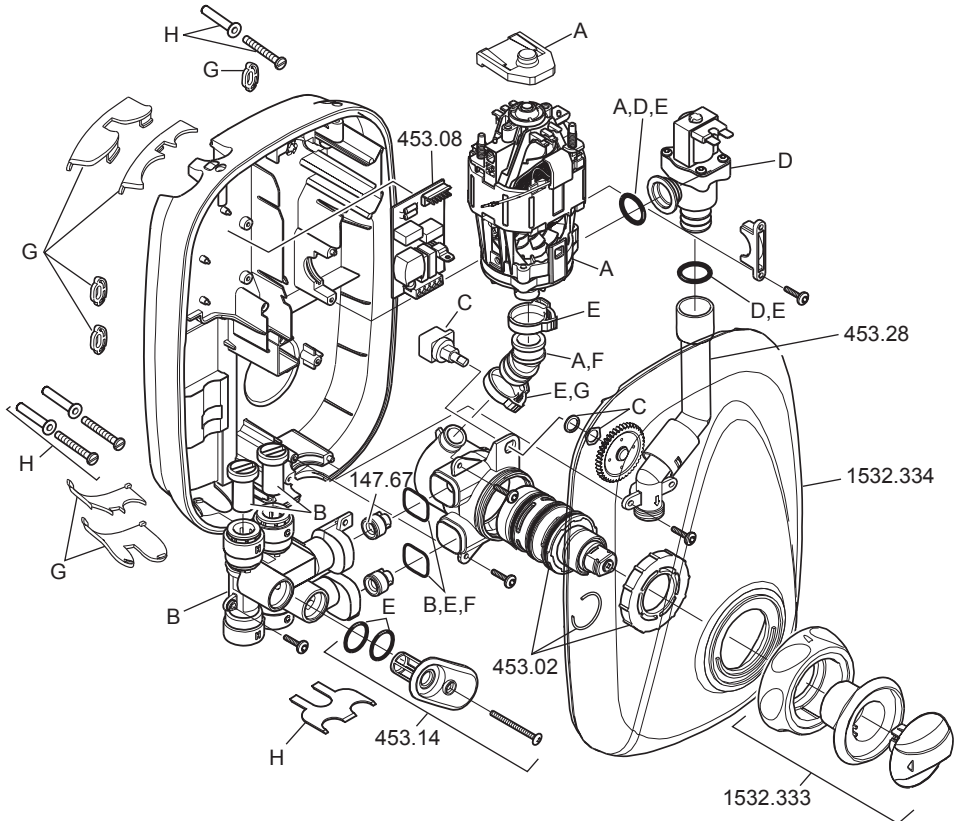

# ACCESSORIES

Genuine Mira accessories can be purchased direct from Customers Services (our contact details can be found on the back cover of this guide) or from approved stockists or merchants.



**Eco Showerhead**  
**White - 2.1668.001**  
**Chrome - 2.1668.002**

The Eco shower head gives you an invigorating shower, but reduces water consumption and heating costs.

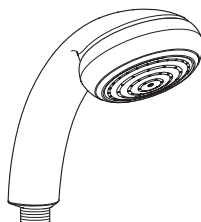

**Everclear Showerhead**  
**White - 2.1616.030**  
**Chrome - 2.1616.031**

Mira's new Everclear range has been specially designed for hard water areas and reduces the risk of lime scale build up.

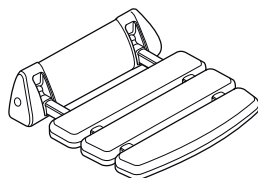

**Shower Seat**  
**White - 2.1536.128**  
**White/Chrome - 2.1536.129**

For use in or out of the showering area. Folds up when not in use. Maximum User Weight - 127 kg (20 stone) **Note!** Must be installed onto a solid wall.



**Premium Shower Seat**  
**White/Chrome - 2.1731.001**  
**Grey/Chrome - 2.1731.002**

Stylish, slim-line and robust shower seat for use in or outside of the shower area. Folds up when not in use. Maximum User Weight - 150 kg (23.5 stone) **Note!** Must be installed onto a solid wall.

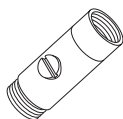

**Double Outlet Check Valve (DCV-H)**  
**Chrome - 1.0.110.55.1**

An outlet double check valve, designed to prevent the back flow or back-siphonage of potentially contaminated water, through shower controls which are fitted with a flexible shower hose as part of the outlet shower fitting.

# NOTES

# CUSTOMER SERVICE

## Guarantee

Your product has the benefit of our manufacturer's guarantee which starts from the date of purchase.

To activate this guarantee, please return your completed registration card, visit our website or free phone 0800 0731248 within 30 days of purchase (UK only).

Within the guarantee period we will resolve defects in materials or workmanship, free of charge, by repairing or replacing parts or product as we may choose.

**This guarantee is in addition to your statutory rights and is subject to the following conditions:**

- The guarantee applies solely to the original installation under normal use and to the original purchaser only. The product must be installed and maintained in accordance with the instructions given in this user guide.
- Servicing must only be undertaken by us or our appointed representative. **Note!** if a service visit is required the product must be fully installed and connected to services.
- Repair under this guarantee does not extend the original expiry date. The guarantee on any replacement parts or product ends at the original expiry date.
- For shower fittings or consumable items we reserve the right to supply replacement parts only.

**The guarantee does not cover:**

- Call out charges for non product faults (such as damage or performance issues arising from incorrect installation, improper use, lack of maintenance, build up of limescale, frost damage, corrosion, system debris or blocked filters) or where no fault has been found with the product.
- Water or electrical supply, waste and isolation issues.
- Compensation for loss of use of the product or consequential loss of any kind.
- Damage or defects caused if the product is repaired or modified by persons not authorised by us or our appointed representative.
- Routine maintenance or replacement parts to comply with the requirements of the TMV 2 or TMV 3 healthcare schemes.
- Accidental or wilful damage.
- Products purchased ex-showroom display.

## What to do if something goes wrong

If your product does not function correctly when you first use it, contact your installer to check that it is installed and commissioned in accordance with the instructions in this manual.

If this does not resolve the issue, contact our Customer Services Team who will offer you or your installer help and advice.

If you experience problems, check in this manual to see if simple home maintenance is required. If you require further assistance call our Customer Services Team.

## Extended Guarantees

A selection of protection plans are available that enable you to cover repair bills for the life of your policy (excludes Eire). Ring 01922 471763 for more details.

## Helpdesk Service

Our Customer Services Team is comprehensively trained and can offer help and advice, spare parts, accessories or a service visit.

We will need you to have your model name or number, power rating (if applicable) and date of purchase. As part of our quality and training programme calls may be recorded or monitored.

## Mira Showers Website ([www.mirashowers.co.uk](http://www.mirashowers.co.uk))

From our website you can register your guarantee, download additional user guides, diagnose faults, purchase our full range of accessories and popular spares, refer to our FAQ's and request a service visit.

## Spares and Accessories

We maintain extensive stocks of genuine spares and accessories and aim to provide support throughout the product's expected life.

Payment can be made by phone at time of order using most major Credit or Debit cards and we aim to despatch orders within 2 working days. Items purchased from us are guaranteed for 12 months from date of purchase. For safety reasons spares exposed to mains voltages should only be fitted by competent persons.

**Returns** – items can be returned within one month of date of purchase, providing that they are in good condition and the packaging is unopened. If you wish to return any items please notify us in writing within seven days of receipt.

## Service / Repairs

We have a nationwide team of Service Technicians can carry out service or repair work to your product within the guarantee period and beyond. You have the assurance of a fully trained Technician, genuine spare parts and a 12 month guarantee on any chargeable work done.

Payment should be made directly to the Service Technician who will accept most major Credit or Debit cards.

## To Contact Us

### UK

**Telephone: 0844 571 5000**

E-mail - Visit [www.mirashowers.co.uk/contactus](http://www.mirashowers.co.uk/contactus)

Fax: 01242 282595

By Post: Mira Customer Services Dept, Cromwell Road, Cheltenham, Gloucestershire, GL52 5EP

### Eire

**Telephone: 01 459 1344**

E-mail: [sales@modernplant.ie](mailto:sales@modernplant.ie)

Fax: Dublin 01 459 2329

By Post: Modern Plant Ltd (Dublin), Otter House, Naas Road, Clondalkin, Dublin 22

Mira is a registered trade mark of  
Kohler Mira Limited.

The company reserves the right to alter  
product specifications without notice.



FM 14648

**mira**

SHOWERS