

***mira***

Element

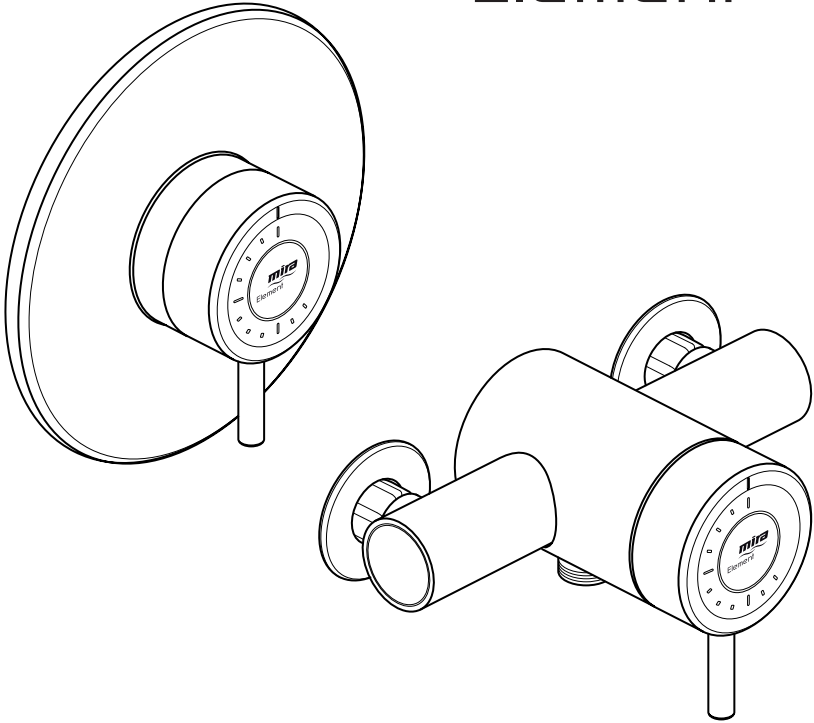

**MIRA ELEMENT**

**THERMOSTATIC MIXER**

**Installation and User Guide**

**These instructions must be left with the user.**

# CONTENTS

<b>Introduction</b> .....	<b>3</b>
Guarantee .....	4
Recommended Usage.....	4
Patents and Design Registration.....	4
<b>Safety : Warnings</b> .....	<b>5</b>
<b>Pack Contents</b> .....	<b>6</b>
<b>Dimensions</b> .....	<b>8</b>
<b>Specifications</b> .....	<b>9</b>
Operating Parameters .....	9
<b>Installation Requirements</b> .....	<b>11</b>
<b>Installation</b> .....	<b>13</b>
General.....	13
Installation Methods .....	14
<b>Exposed Thermostatic Mixer</b> .....	<b>15</b>
1. Rear Entry Supplies (rising or falling concealed pipework).....	15
2. Rising or Falling Supplies.....	17
<b>Built-in Thermostatic Mixer</b> .....	<b>19</b>
1. Solid Wall or Stud Partition (Using Securing Brackets - Mounting off Front Face of Wall) ....	19
2. Solid Wall or Stud Partition (Using Rear Fixing Points on the Thermostatic Mixer).....	22
3. Laminated Panel (Using Securing Brackets - Mounting on Rear Face of Wall).....	24
Control Assembly (Built-in Models) .....	26
<b>Reversed Inlet Supplies</b> .....	<b>27</b>
<b>Commissioning</b> .....	<b>29</b>
Maximum Temperature Setting .....	29
<b>Operation</b> .....	<b>30</b>
<b>Fault Diagnosis</b> .....	<b>31</b>
<b>Maintenance</b> .....	<b>32</b>
<b>Type 2 Valves</b> .....	<b>36</b>
<b>Spare Parts</b> .....	<b>37</b>
<b>Accessories</b> .....	<b>41</b>
<b>Customer Service</b> .....	<b>Back Page</b>

# INTRODUCTION

Thank you for purchasing a quality Mira product. To enjoy the full potential of your new product, please take time to read this guide thoroughly, having done so, keep it handy for future reference.

The Mira Element Thermostatic Mixer is a Thermostatic Shower Control with a single control lever for on/off and temperature control.

There is no adjustable flow control. A 12 L/Min flow regulator is supplied for high pressure systems to reduce excessive shower force.

The Thermostatic Mixer incorporates a wax capsule temperature sensing unit, which provides an almost immediate response to changes in pressures or temperature of the incoming water supplies to maintain the selected temperature. An adjustable maximum temperature stop is provided which limits the temperature to a safe level. Inlet Filters are fitted to protect the thermostatic cartridge.

**Mira Element Exposed:** Thermostatic Mixer for connection to rising, falling or rear entry pipework, supplied with L10 EV Shower Fittings.

**Mira Element Built-in:** Thermostatic Mixer for connection to concealed pipework, supplied with L10 BIV or BIR Shower Fittings.

This product has been certified as a Type 2 valve under the BUILDCERT TMV2 scheme. This product also complies with the Water Supply (water fittings) Regulations 1999.

If you experience any difficulty with the installation or operation of your new Thermostatic Mixer, please refer to '**Fault Diagnosis**', before contacting Kohler Mira Ltd. Our telephone and fax numbers can be found on the back cover of this guide.

## Guarantee

For **domestic installations**, Mira Showers guarantee the Mira Element against any defect in materials or workmanship for a period of **five** years from the date of purchase (shower fittings for one year).

For **non-domestic installations**, Mira Showers guarantee the Mira Element against any defect in materials or workmanship for a period of **one** year from the date of purchase.

For terms and conditions refer to the back cover of this guide.

## Recommended Usage

Application	Valve with Fittings
Domestic	✓
Light Commercial	✓
Heavy Commercial	×
Healthcare	×

## Patents and Design Registration

Design Registration:	000555768-0006, 000555768-0007	
Patents:	GB:	2 291 693, 2 392 225, 2 421 297
	Germany:	695 13 455.8
	France:	0 694 721 (E)
	USA:	7 240 850
Patent Applications:	GB:	0621637.8
	Euro:	1 672 257, 03254070.0
	USA:	2006-0124758-A1

# SAFETY : WARNINGS

This Mira Element Thermostatic Mixer is precision engineered and should give continued safe and controlled performance, provided:

1. It is installed, commissioned, operated and maintained in accordance with manufacturers recommendations.
2. Periodic attention is given, when necessary, to maintain the product in good functional order.

## Caution!

1. **Read all of these instructions and retain this guide for later use.**
2. Make sure that this guide is left with the user. Pass on this guide in the event of change of ownership of the installation site.
3. Follow all warnings, cautions and instructions contained in this guide, and on or inside the shower.
4. Installation must be carried out in accordance with these instructions, and must be conducted by designated, qualified and competent personnel.
5. The plumbing installation must comply with the requirements of UK Water Regulations/Bye-laws (Scotland), Building Regulations or any particular regulations and practices, specified by the local water company or water undertakers. The installation should be carried out by a plumber or contractor who is registered, or is a member of, an association such as:  
Institute of Plumbing (IOP), throughout the UK  
National Association of Plumbing, Heating and Mechanical Services Contractors (NAPH & MSC), England and Wales  
Scottish and Northern Ireland Plumbing Employers' Federation (SNIPEF), Scotland and Northern Ireland
6. The temperature control can be turned from **FULL HOT** to **FULL COLD**. As such, turning the control to full hot will deliver water at the hot water storage temperature.
7. This appliance is not intended for use by persons (including children) with reduced physical, sensory or mental capabilities, or lack of experience and knowledge, unless they have been given supervision or instruction concerning the use of the appliance by a person responsible for their safety.
8. Children should be supervised to make sure that they do not play with the appliance.
9. Sunburn or skin conditions can increase your sensitivity to hot water.
10. If water leaks from the pressure relief valve, maintenance will be required before the appliance can be safely used.
11. If the shower is dismantled during installation or servicing then upon completion the product must be inspected to ensure there are no leaks.

12. **DO NOT** commission this appliance if water leaks from the unit.
13. **DO NOT** operate this appliance if water leaks from this appliance.
14. The shower head must be de-scaled regularly. Lack of regular shower head cleaning will lead to poor performance and cause early failure of the appliance. Refer to the Shower Fittings User Guide for more information.
15. If pipework and/or electrical cables enter the shower from the rear through a hole in the wall . Provision must be made to prevent water ingress back into the wall structure.
16. Care is required when adjusting flow or temperature, make sure that the temperature has stabilised.
17. Rapid/Excessive movement of the flow and/or temperature control levers may result in momentary unstable blend temperatures.
18. Make sure that you fully understand how to operate this shower and make sure that it is properly maintained in accordance with the instructions given in this manual.
19. Having completed the installation, make sure that the user is familiar with the operation of the appliance.
20. When this appliance has reached the end of its serviceable life, it should be disposed of in a safe manner, in accordance with current local authority recycling, or waste disposal policy.

# PACK CONTENTS



Tick the appropriate boxes to familiarize yourself with the part names and to confirm that the parts are included.

## Exposed Element Thermostatic Mixer

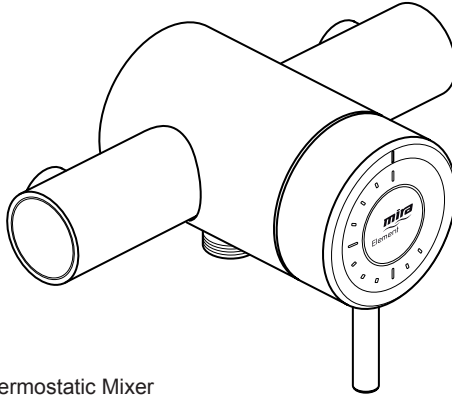

1 x Mira Element Thermostatic Mixer

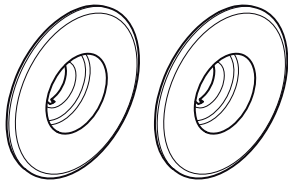

2 x Concealing Plates

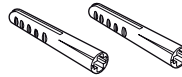

2 x Wall Plugs



2 x No 8 x 1 1/4" Securing Screws

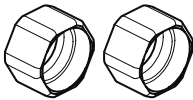

2 x Compression Nuts



1 x 2.5 mm Hexagon Key



2 x Olives

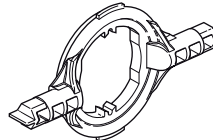

1 x 'O' Key



1 x 12 L/Min Flow Regulator

## Documentation

1 x Guarantee Registration Document

1 x Installation Template

# Built-in Element Thermostatic Mixer

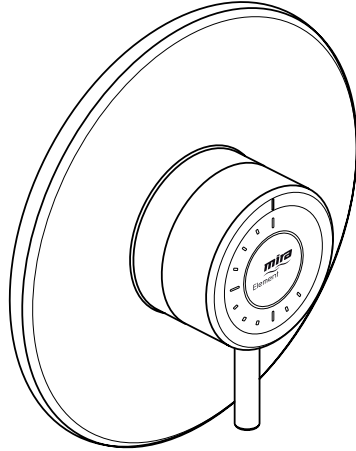
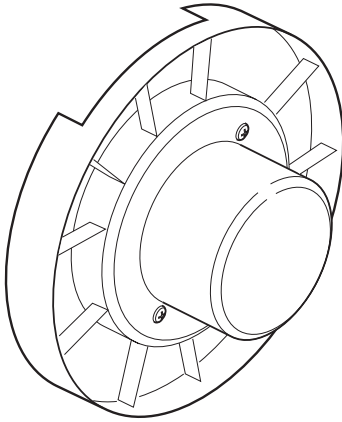

1 x Mira Element Thermostatic Mixer  
(attached to the Building-in Shroud)

1 x Control Assembly

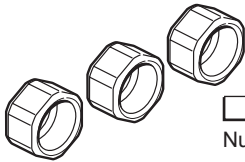

3 x Compression Nuts



3 x Olives



1 x 12 L/Min Flow Regulator



1 x 2.5 mm Hexagon Key

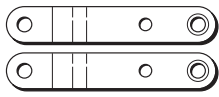

2 x Securing Brackets



2 x Bracket Securing Screws

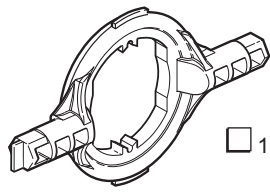

1 x 'O' Key

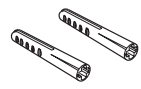

2 x Wall Plugs



2 x No 8 x 1 1/4" Screws

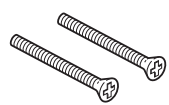

2 x M5 x 40 mm Screws

## Documentation

1 x Guarantee Registration Document



# DIMENSIONS

## Exposed Element Thermostatic Mixer

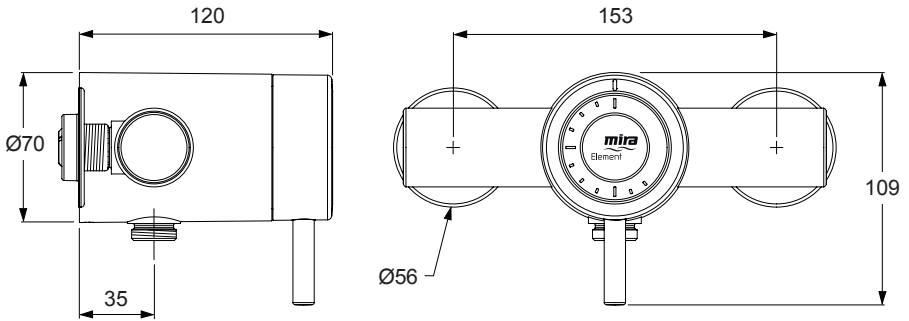

## Built-in Element Thermostatic Mixer

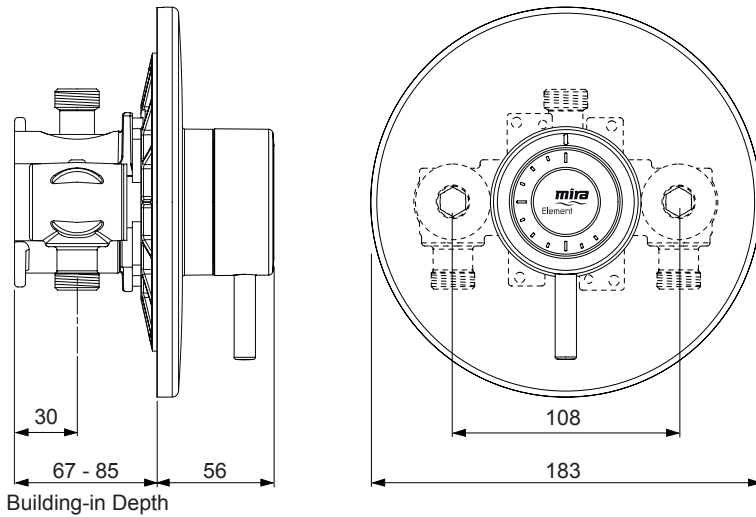

All dimensions in mm.

# SPECIFICATIONS

## Operating Parameters

For Type 2 Valves, the supply conditions specified in section: '**Type 2 Valves - Application**' take precedence over the operating parameters which follow.

### Pressures

Maximum Static Pressure: **10 Bar**.

Maximum Maintained Pressure: **5 Bar**.

Minimum Maintained Pressure (Gas Water Heater): **1.0 Bar**.

(for optimum performance supplies should be nominally equal).

Minimum Maintained Pressure (Gravity System): **0.1 Bar**.

(0.1 bar = 1 Metre head from base of cold tank to the outlet of the shower handset).

**Note!** For combination type boilers it may be necessary to fit the flow regulator (supplied) to restrict the flow through the boiler to ensure it produces a sufficiently hot water temperature.

**Important!** The fitting of flow regulators will invalidate any TMV2 compliance due to the minimum flow rate requirements. Do not fit the flow regulator in TMV2 applications.

### Temperatures

Factory Pre-set (Blend) Shower: **43°C**.

Optimum Thermostatic Control Range: **35°C - 45°C**.

(Achieved with supplies of 15°C cold, 65°C hot and nominally equal pressures).

Recommended Hot Supply: **60°C - 65°C**.

**Note!** The Mixing Valve can operate at temperatures up to 85°C for short periods without damage. However for safety reasons it is recommended that the maximum hot water temperature is limited to 65°C.

Minimum Differential between Hot Supply and Outlet Temperature: **10°C at desired flow rates**.

Cold Water Range: **5°C - 25°C**.

### Thermostatic Shut-down

For safety the Thermostat will shut off the Hot Supply **Within 2 Seconds** if the Cold Supply Fails.

(Achieved only if the hot supply temperature is greater than 10°C above the set blend temperature).

### Connections

#### Exposed Mixer:

Inlets: 15 mm Compression, **Hot - Left, Cold - Right**.

Outlet: ½" BSP Flat Face, **Bottom - Outlet**.

#### Built-in Mixer:

Inlets: 15 mm Compression, **Hot - Left, Cold - Right**.

Outlet: 15 mm Compression, **Top - Outlet**.

If reversed inlets are required refer to section: '**Reversed Inlet Supplies**'.

## Flow Regulator Installation

Flow regulators are supplied with this product and should be fitted in high pressure systems to either;

1. Reduce Excessive Force & Flow Rate
2. Reduce Noise through the mixer due to high or unequal pressures
3. Stabilise incoming supply temperatures

## Flow Rates

Typical Flow Rates on Low Pressure Systems (0.1 Bar to 1 Bar) - Mira Element with L10 Adjustable Fittings or Rigid Head:

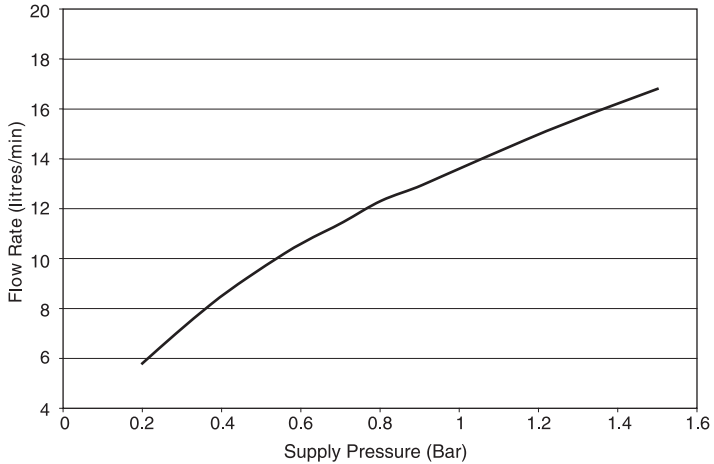

Typical Flow Rates on High Pressure Systems (1 Bar to 5 Bar, with 12 Litre/Min Flow Regulator fitted in shower control outlet) - Mira Element with L10 Adjustable Fittings or Rigid Head:

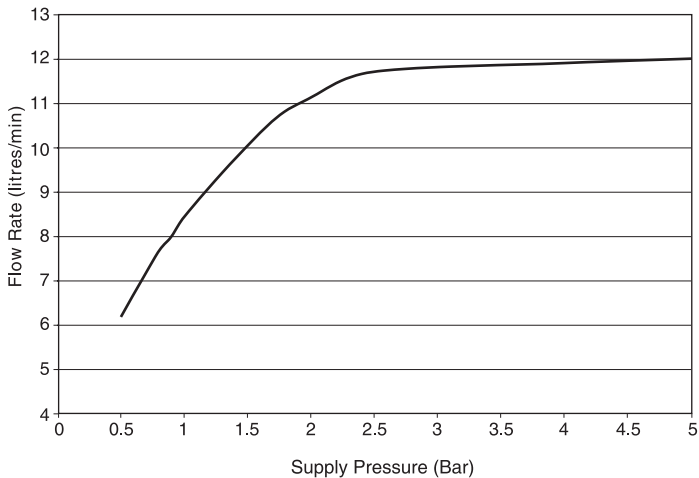

# INSTALLATION REQUIREMENTS

## Key to Symbols

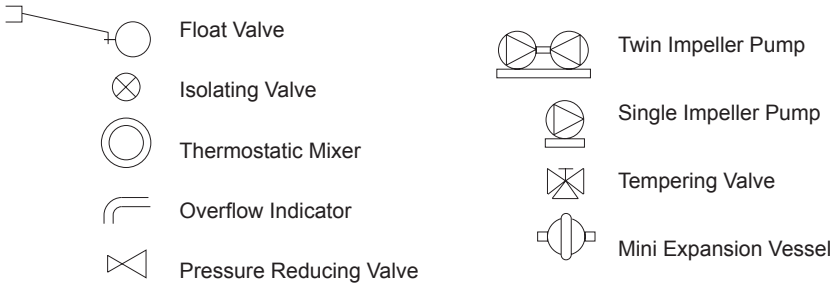

The Mira Element Thermostatic Mixer is compatible with the following systems:

### Gravity fed system

The Thermostatic Mixer **MUST** be fed from a cold water cistern and hot water cylinder providing nominally equal pressure.

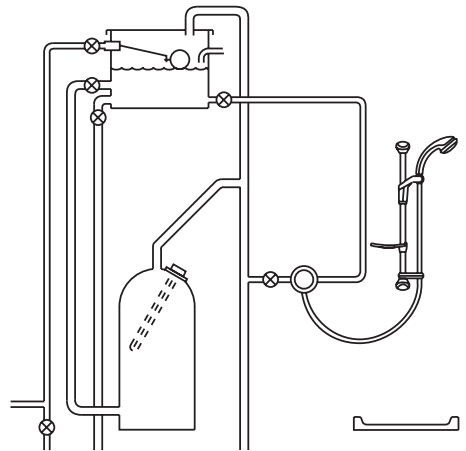

### Gas heated system

The Thermostatic Mixer **MUST** be installed with a gas water heater or combination boiler of a fully modulating design.

**Note!** We recommend the use of a 12 L/Min Outlet Flow Regulator (supplied). However, it is possible following the installation of the Flow Regulator that the flow rate is reduced too much for the boiler to ignite. If this is the case remove the flow regulator.

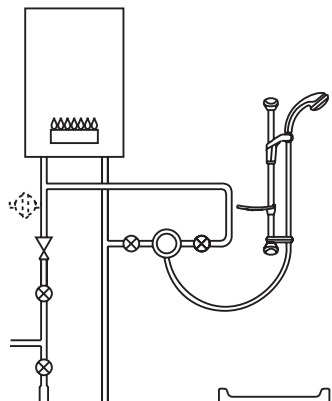

### Unvented mains pressure system

The Thermostatic Mixer can be installed with a unvented, stored hot water cylinder.

**Note!** We recommend the use of a 12 L/Min Outlet Flow Regulator (supplied).

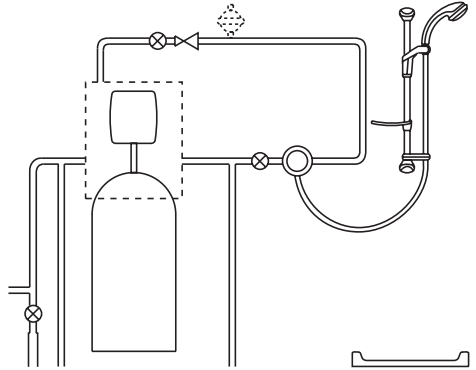

### Mains pressurised instantaneous hot water system (thermal store)

The Thermostatic Mixer can be installed with systems of this type with balanced pressures.

**Note!** We recommend the use of a 12 L/Min Outlet Flow Regulator (supplied).

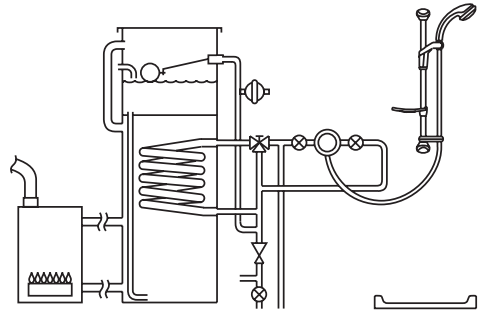

### Pumped system

The Thermostatic Mixer can be installed with an inlet pump (twin impeller). The pump must be installed on the floor next to the hot water cylinder.

**Note!** We recommend the use of a 12 L/Min Outlet Flow Regulator (supplied).

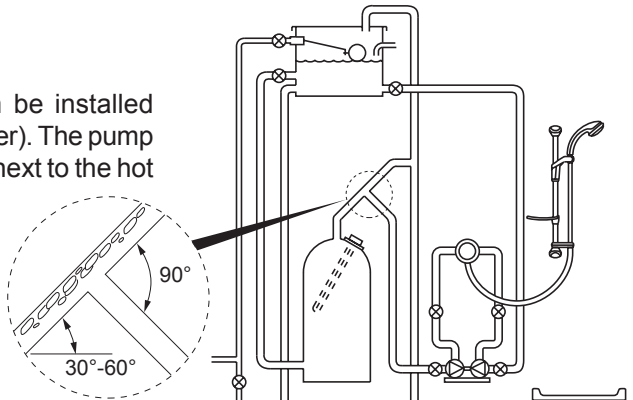

Air Separation

# INSTALLATION

## General

Installation must be carried out in accordance with these instructions, and must be conducted by designated, qualified and competent personnel.

The installation must comply with the “Water Supply Regulations 1999 (Water Fittings)” or any particular regulations and practices, specified by the local water company or water undertakers.

**Note!** Make sure that all site requirements correspond to the information given in section: ‘**Specifications**’. For Type 2 Valves see also supply conditions in section: ‘**Type 2 Valves**’.

1. The Mixer must not be installed in an area where it may freeze.
2. For stud partitions alternative fixings may be required.
3. Isolating valves must be installed close to the Mixer for ease of maintenance.
4. Pipework must be rigidly supported and avoid any strain on the connections.
5. Pipework dead-legs should be kept to a minimum.
6. Supply pipework layout should be arranged to minimise the effect of other outlet usage upon the dynamic pressures at the Mixer inlets.
7. Inlet and outlet threaded joint connections should be made with PTFE tape or liquid sealant. Do not use oil-based, non-setting joint compounds.
8. To eliminate pipe debris it is essential that supply pipes are thoroughly flushed through before final connection.
9. Decide on a suitable position for the Mixer. The position of the Mixer and the Shower Fittings must provide a minimum gap of 25 mm between the spill-over level of the shower tray/bath and the handset. This is to prevent back-siphonage. For further information on the installation of your **Shower Fittings**, refer to the Fittings Installation and User Guide.

**Note!** Only use Shower Fittings recommended by the manufacturer or supplier.

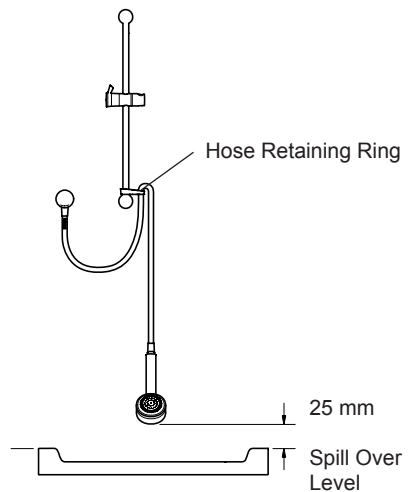

# Installation Methods

## Exposed Element Thermostatic Mixer

The **Exposed** Element Mixer can be installed with rear, rising or falling supply inlets.

For rear entry supplies, go to section: **‘Exposed Thermostatic Mixer, 1. Rear Entry Supplies’**.

For rising or falling supplies, go to section: **‘Exposed Thermostatic Mixer, 2. Rising or Falling Supplies’**.

## Built-in Element Thermostatic Mixer

The **Built-in** Element Mixer can be installed with rising or falling supply inlets (rising inlets are illustrated).

The Mixer can be installed using Rear Fixing Points on the Body, or by using the Securing Brackets (supplied) on the Front Face of a Solid Wall or Stud Partition, or on the Rear Face of a Laminated Panel.

For installation into a Solid Wall or Stud Partition using the Securing Brackets, go to section: **‘Built-in Thermostatic Mixer, 1. Solid Wall or Stud Partition (Using Securing Brackets - Mounting on Front Face of Wall)’**.

For installation into a Solid Wall or Stud Partition using the Rear Fixing Points, go to section: **‘Built-in Thermostatic Mixer, 2. Solid Wall or Stud Partition (Using Rear Fixing Points on Thermostatic Mixer)’**.

For installation behind a Laminated Panel using the Securing Brackets, go to section: **‘Built-in Thermostatic Mixer, 3. Laminated Panel (Using Securing Brackets - Mounting on Rear Face of Wall)’**.

Rear Entry Supplies

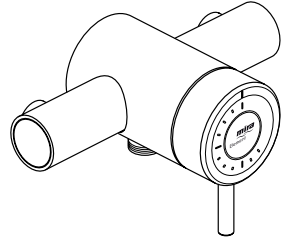

Rising or Falling Supplies

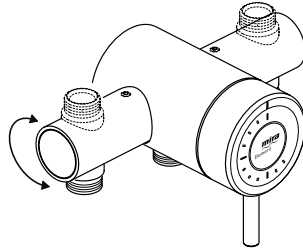

Securing Brackets  
(Mounting on Front  
Face of Wall)

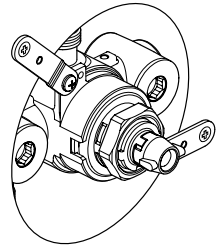

Mounting using  
Rear Fixing Points

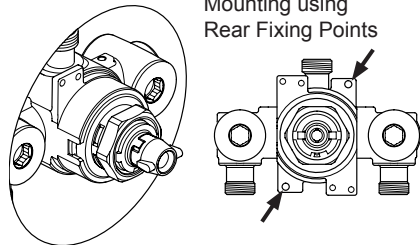

Securing Brackets  
(Mounting on Rear  
Face of Wall)

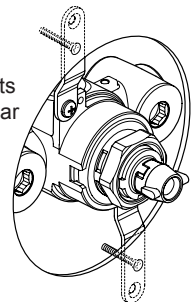

# Exposed Thermostatic Mixer

## 1. Rear Entry Supplies (rising or falling concealed pipework)

1.1 Use the Installation Template to mark the positions of the holes for the Backplate and the pipe centres.

**Note!** Allow a minimum of 150 mm either side of the Mixer, to allow access to the hot and cold Inlet Filters for servicing.

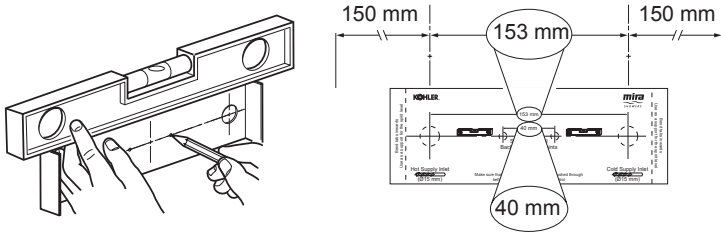

1.2 For solid walls drill the holes for the Backplate with a 6 mm drill and insert the Wall Plugs (supplied). For other types of wall structure alternative fixings may be required (not supplied).

1.3 Drill the holes for the supply pipes at 153 mm centres.

1.4 Recess the wall to allow for the Concealing Plates, Ø 32 mm x 10 mm deep.

**Note!** Depth must be sufficient to prevent the Concealing Plates fouling on the plumbing Elbows.

1.5 Fit the supply pipework (**Hot - Left, Cold - Right**). The pipework must project 18 mm from the finished wall surface at 153 mm centres (use the Installation Template as a guide).

**Note!** If the connections are reversed, complete the installation then refer to section: '**Reversed Inlet Supplies**' before commissioning.

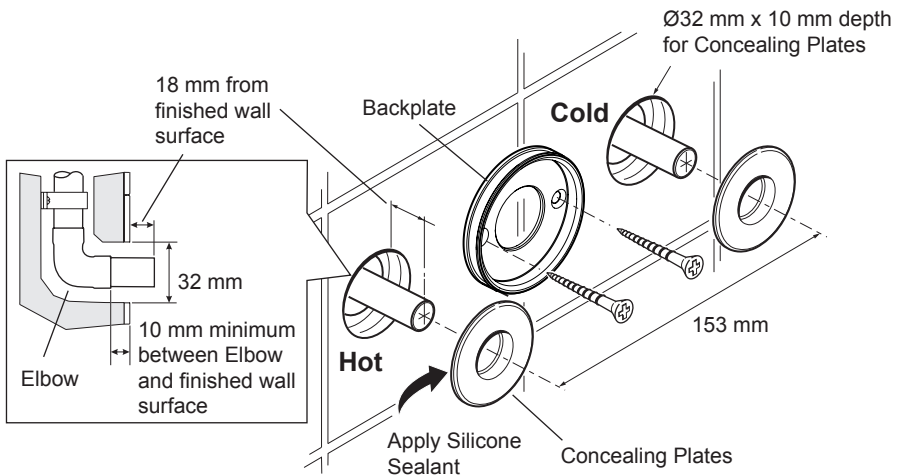



- 1.6 Loosen the Grubscrew with the 2.5 mm Hexagon Key (supplied) and remove the Backplate from the Mixer.
  - 1.7 Secure the Backplate to the wall using the Screws (supplied).
  - 1.8 Fit the Concealing Plates.
- Note!** Apply silicone sealant to the back face of the flange.
- Caution!** It is essential at this point that the supply pipework is thoroughly flushed through before connection to the Mixer. Failure to do so may result in product malfunction.
- 1.9 Fit the Compression Nuts and Olives onto the pipework.
  - 1.10 Align the Mixer with the pipework and fit onto the Backplate.
  - 1.11 Tighten the Compression Nuts onto the Mixer with a suitable Spanner.
- Caution!** Take care not to damage the chrome surfaces.

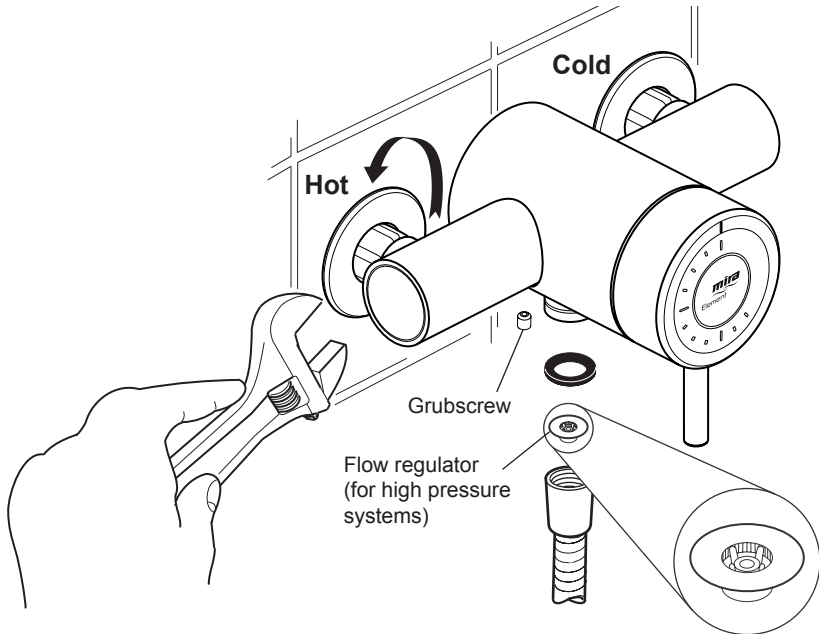

- 1.12 Tighten the Grubscrew to secure the Mixer to the Backplate.
  - 1.13 Fit the **Shower Fittings**, refer to your Shower Fittings Installation and User Guide for Instructions.
- Note!** For high pressure systems, a 12 litre/minute Flow Regulator (supplied) can be fitted under the Hose Washer (refer to illustration).
- 1.14 Turn on the hot and cold water supplies and check for leaks.
  - 1.15 Before using the Shower, refer to section: '**Commissioning**'.

## 2. Rising or Falling Supplies

**2.1** Loosen the Grubscrew on each Elbow using the 2.5 mm Hexagon Key (supplied) and rotate the Elbow 90° as required. Retighten the Grubscrews.

**2.2** Use the Installation Template to mark the positions of the fixing holes for the Backplate.

**Note!** Allow a minimum of 150 mm either side of the Mixer, to allow access to the hot and cold Inlet Filters for servicing.

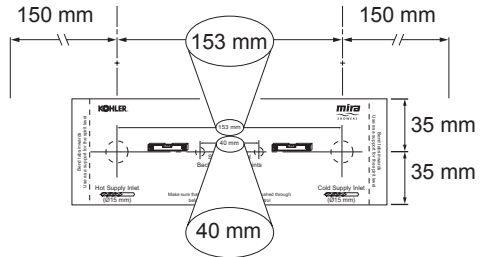
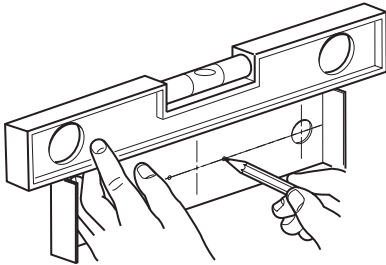
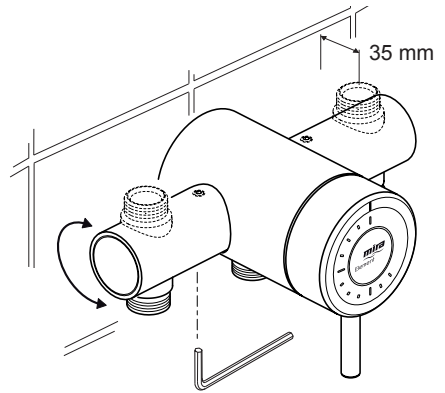

**2.3** For solid walls drill the holes for the Backplate with a 6 mm drill and insert the Wall Plugs (supplied). For other types of wall structure alternative fixings may be required (not supplied).

**2.4 For Falling Supplies:** Using the Installation Template as a guide, mark the pipe positions on the ceiling and set the 35 mm centres from the finished wall (refer to illustration).

**For Rising Supplies:** Using the Installation Template as a guide, mark the pipe positions and set the 35 mm centres from the finished wall.

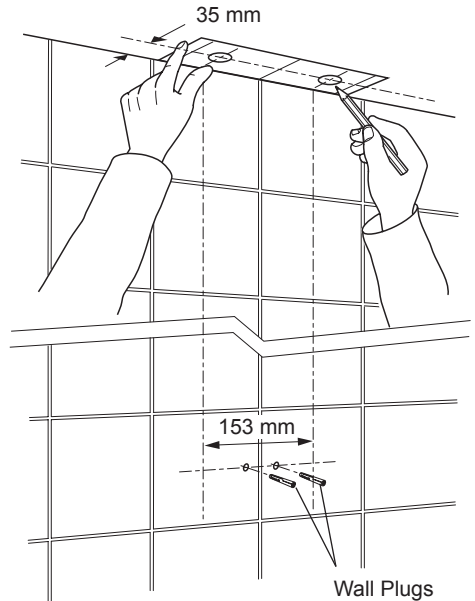

- 2.5** Fit the supply pipework (**Hot - Left, Cold - Right**).

**Note!** If the connections are reversed, complete the installation then refer to section: '**Reversed Inlet Supplies**' before commissioning.

- 2.6** Loosen the Grubscrew with the 2.5 mm Hexagon Key (supplied) and remove the Backplate from the Mixer.
- 2.7** Secure the Backplate to the wall using the Screws (supplied).

**Caution!** It is essential at this point that the supply pipework is thoroughly flushed through before connection to the Mixer. Failure to do so may result in product malfunction.

- 2.8** Fit the Compression Nuts and Olives onto the pipework.
- 2.9** Align the Mixer with the pipework and fit onto the Backplate.

- 2.10** Tighten the Compression Nuts onto the Mixer with a suitable Spanner.

**Caution!** Take care not to damage the chrome surfaces.

- 2.11** Tighten the Grubscrew to secure the Mixer to the Backplate.
- 2.12** Fit the **Shower Fittings**, refer to your Shower Fittings Installation and User Guide for Instructions.

**Note!** For high pressure systems, a 12 litre/minute Flow Regulator (supplied) can be fitted under the Hose Washer (refer to illustration).

- 2.13** Turn on the hot and cold water supplies and check for leaks.
- 2.14** Before using the Shower, refer to section: '**Commissioning**'.

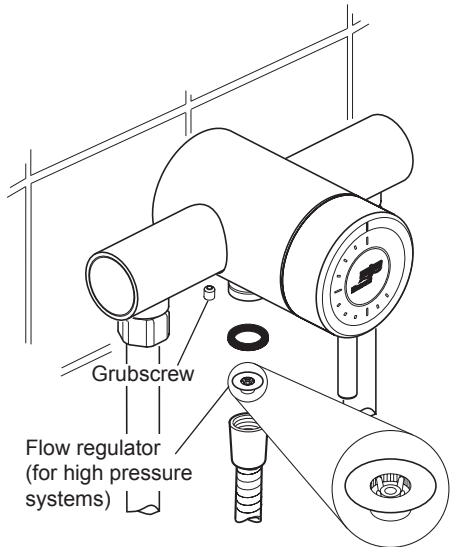
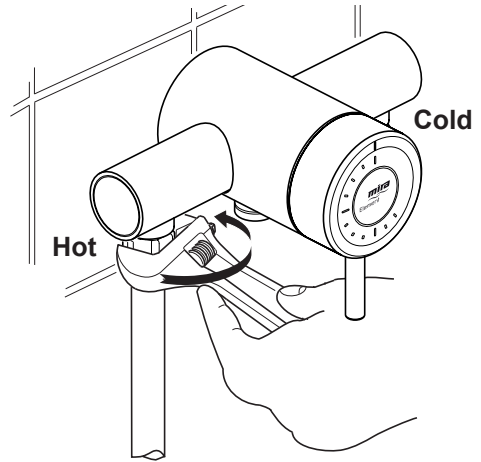

# Built-in Thermostatic Mixer

## 1. Solid Wall or Stud Partition

### (Using Securing Brackets - Mounting off Front Face of Wall)

1.1 Determine the route for the hot and cold supply pipework and for the outlet pipework. When connecting to the BIV Shower Fittings it is recommended that the outlet be positioned above and to one side of the Mixer. This is to prevent the Flexible Hose from obstructing the Shower Controls.

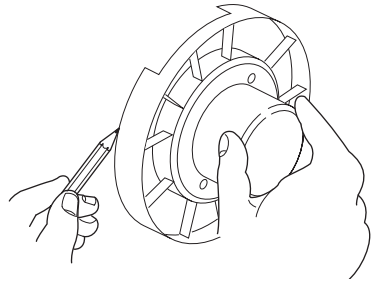

1.2 Remove the two Shroud Screws (retain for later use) and remove the Mixer from the Building-in Shroud.

1.3 Determine the position of the Mixer and draw around the Building-in Shroud.

1.4 Mark the routes for the hot and cold supply pipework at 108 mm centres (**Hot - Left, Cold - Right**).

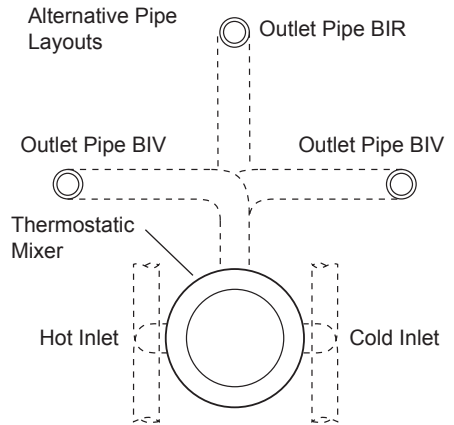

**Falling Supplies:** For falling supplies loosen the Grubscrew on each Elbow using the 2.5 mm Hexagon Key (supplied). Remove the Elbows and install on opposite sides. Retighten the Grubscrews.

**Caution!** Do not overtighten.

**Note!** Make sure that the 'O' Seals are correctly fitted and that the Filter Plugs are positioned to the front (i.e. Hexagonal Key facing forward).

1.5 Mark the route for the outlet pipework.

**Note!** The Outlet Elbow should be sited above the Mixer and on the right or left, as site dictates.

1.6 Remove the plasterboard and/or brick work to a minimum depth of 62 mm.

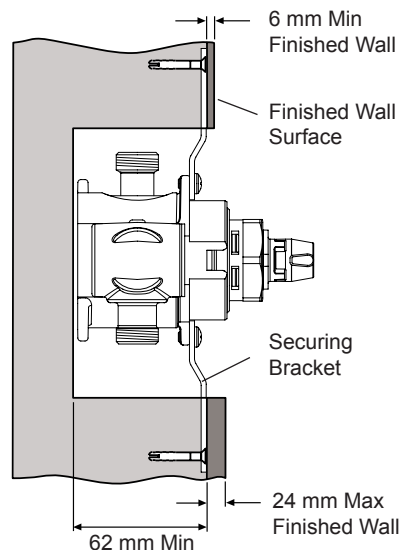

**1.7** Fit the Securing Brackets to the Mixer with the Bracket Securing Screws.

**Important!** Make sure that the correct holes are used, otherwise the Backplate cannot be fitted.

**Note!** The Securing Brackets can be rotated for suitable fixing points.

**1.8** Make sure that the Mixer is level and mark the positions for the countersunk fixing holes on the wall.

**1.9** For solid walls drill two 6 mm holes for the Wall Plugs.

**Caution!** Do not drill into pipes in the wall.

**1.10** Fit the Wall Plugs (supplied) and fix the Mixer to the wall with the Screws provided.

**Note!** For stud partition installations alternative fixings may be required (not supplied).

**1.11** Connect the hot and cold supply pipes and tighten the Compression Nuts.

**Caution!** Make sure that the Olives are fitted and all pipework is flushed through before connecting to the Mixer.

**1.12** Connect the outlet pipework, leaving enough pipe through the wall to temporarily cap off (refer to your Shower Fittings Installation and User Guide).

**1.13** Turn on the water supplies and check for leaks.

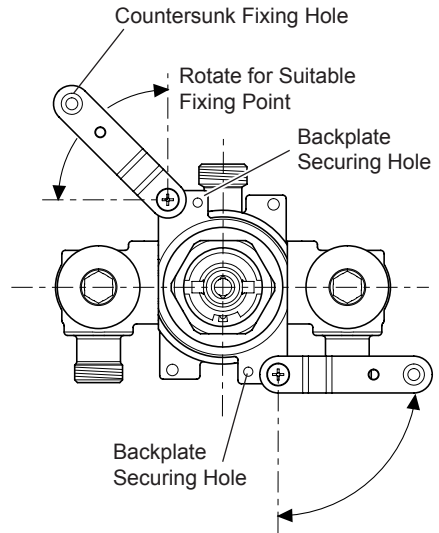

**Note!** Securing Brackets shown in preferred position to allow the Compression Nuts to be tightened.

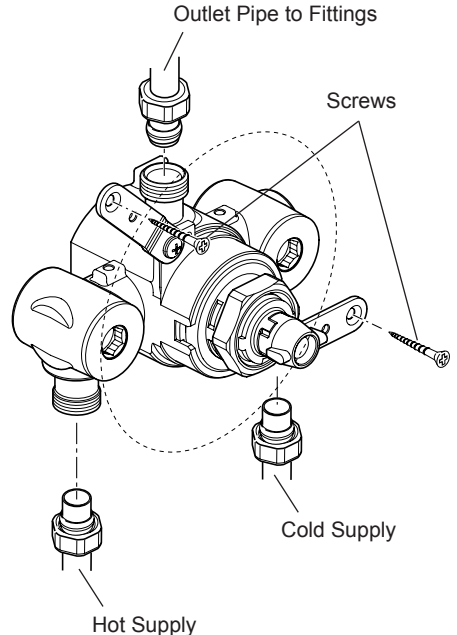

**1.14** Attach the Building-in Shroud to the Mixer using the two Shroud Screws removed earlier.

**1.15** Using the 'Finished Wall Indicator' on the Building-in Shroud as a guide, finish the wall, e.g. tiles.

**Caution!** Make sure that the finished wall is within the maximum and minimum limits and to an even depth (no greater than 2 mm variation) or the control components will not fit correctly.

**1.16** Remove the two Shroud Screws (retain for later use) and remove the Building-in Shroud.

**1.17** Fit the **Shower Fittings**, refer to your Shower Fittings Installation and User Guide for Instructions.

**Note!** For high pressure systems, a 12 litre/minute flow regulator (supplied) can be fitted under the hose washer.

**1.18** Fit the Concealing Plate and Control Assembly, refer to section: '**Control Assembly**'.

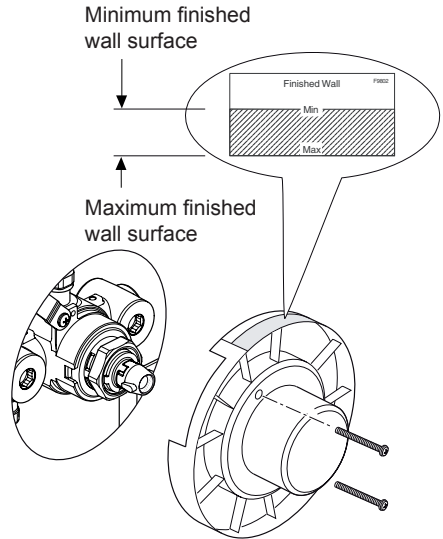

## 2. Solid Wall or Stud Partition (Using Rear Fixing Points on the Thermostatic Mixer)

2.1 Refer to section: '1. Solid Wall or Stud Partition (Using Securing Brackets - Mounting off Front Face of Wall)' and follow steps 1.1 to 1.4.

2.2 Cut away the plasterboard and/or brick work to the required depth.

**Important!** This depth 'X' will depend on the finished wall thickness e.g. tiles or facia board. Refer to the table for this measurement.

For stud partitions depth 'X' refers to the distance from the rear mounting e.g. timber noggin, to the front of the wall (before tiling).

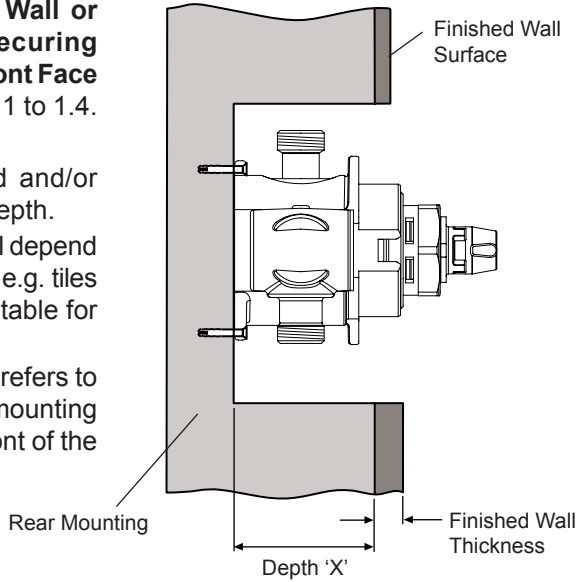

Finished Wall Thickness (e.g. tile and adhesive)	Wall Cutout Depth 'X'
4 mm	81 - 63 mm
6 mm	79 - 61 mm
8 mm	77 - 59 mm
10 mm	75 - 57 mm
12 mm	73 - 55 mm
14 mm	71 - 55 mm
16 mm	69 - 55 mm
18 mm	67 - 55 mm
20 mm	65 - 55 mm
22 mm	63 - 55 mm
24 mm	61 - 55 mm

- 2.3** Make sure that the Mixer is level and central in the hole, and square to the finished wall surface (or the control components will not fit correctly), then mark the positions of the Fixing Screw holes on the wall.
- 2.4** For solid walls drill two 6 mm holes for the Wall Plugs.
- 2.5** Insert the Wall Plugs (supplied) and attach the Mixer to the wall with the Screws provided.
- Note!** For stud partition installations alternative fixings may be required (not supplied) to fix the Mixer to the rear face of the wall cavity or to a timber noggin.
- 2.6** Refer to section: **'1. Solid Wall or Stud Partition (Using Securing Brackets - Mounting off Front Face of Wall)'** and follow steps 1.10 to 1.18.

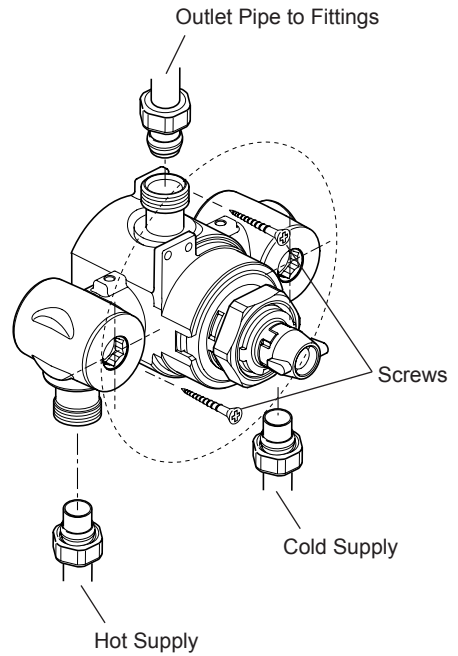



### 3. Laminated Panel (Using Securing Brackets - Mounting on Rear Face of Wall)

**Note!** For laminated panels the Mixer must be positioned from the rear of the panel. Panel thickness must be between 4 and 12 mm (if a thicker panel is used, it will be necessary to recess the Securing Brackets into the rear of the panel).

**Important!** Make sure that there is a minimum clearance of 64 mm behind the laminated panel to house the Mixer.

**3.1** Remove the two Shroud Screws (retain for later use) and remove the Mixer from the Building-in Shroud.

**3.2** Mark the position of the Mixer using the Building-in Shroud as a guide.

**3.3** Carefully cut out the laminated panel.

**3.4** Fit the Securing Brackets to the Mixer.

**Important!** The Securing Brackets must be fixed vertically, as illustrated.

**Important!** Make sure that the correct holes are used, otherwise the Backplate cannot be fitted.

**3.5** Position the Mixer on the front of the panel, make sure that it is level and central in the hole, then mark the position of the M5 fixing holes.

**Important!** Make sure that the correct holes are used (refer to illustration).

**Note!** Make sure that the Filter Plugs are positioned so that they can be removed for servicing.

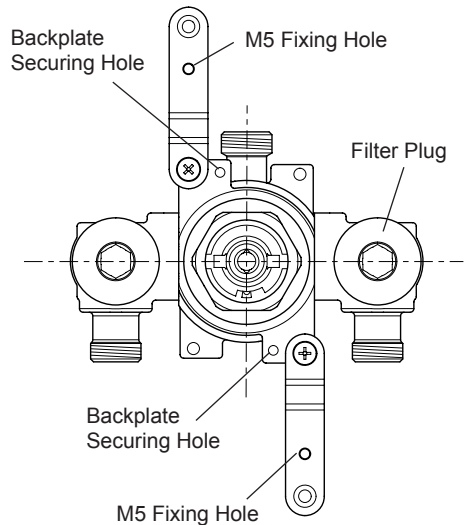
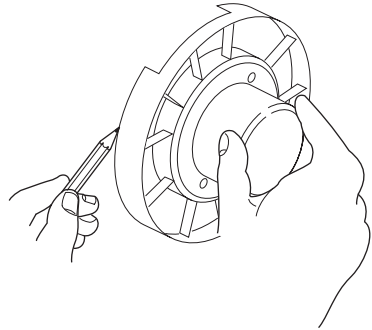

**3.6** Drill the two 5.5 mm holes for the fixing positions (countersink the holes at the front).

**3.7** Secure the Mixer with the M5 x 40 screws as shown.

**3.8** Fit the hot and cold supply pipes (**hot - left, cold - right**) and tighten the compression nuts.

**Falling Supplies:** For falling supplies loosen the Grubscrew on each Elbow using the 2.5 mm Hexagon Key (supplied). Remove the Elbows and install on opposite sides. Retighten the Grubscrews.

**Caution!** Do not overtighten.

**Caution!** Make sure that the olives are fitted and all pipework is flushed through before connecting to the Mixer.

**3.9** Fit the outlet pipework, leaving enough pipe through the wall to temporarily cap off (refer to your Shower Fittings Installation and User Guide).

**3.10** Turn on the water supplies and check for leaks.

**3.11** Fit the **Shower Fittings**, refer to your Shower Fittings Installation and User Guide for Instructions.

**Note!** For high pressure systems, a 12 litre/minute flow regulator (supplied) can be fitted under the hose washer.

**3.12** Fit the Concealing Plate and Control Assembly, refer to section: '**Control Assembly**'.

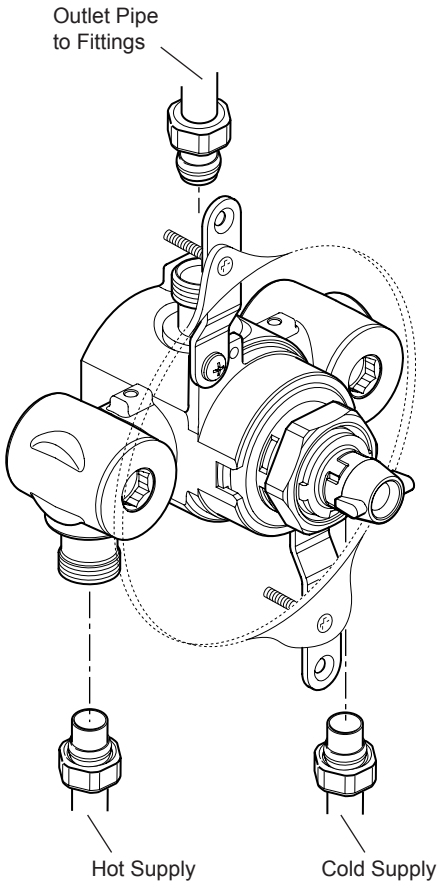
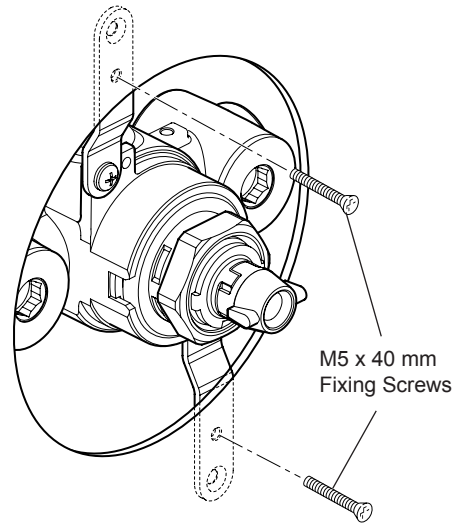

## Control Assembly (Built-in Models)

1. Unscrew and remove the Control Lever Handle.
2. Loosen the Grubscrew (by approximately 4 turns) and pull off the Control Lever and Bearing.
3. Carefully unclip the Concealing Plate from the Backplate.  
**Note!** Use a screwdriver in the cutout to assist separation.
4. Align the slots in the Backplate with the lugs on the Hub (refer to illustration), and fit the Backplate to the Mixer.
5. Align the holes in the Backplate with the threaded holes on the Mixer and secure with the two Shroud Screws (removed earlier).  
**Note!** Make sure that the Foam Seal is fully compressed. **Do not overtighten.**
6. With the cutout at the bottom, locate the Concealing Plate over the Mixer, engage the crosses in the Concealing Plate with the square recesses in the Backplate, and push firmly until the Concealing Plate clicks into position.
7. With the lug in the 8 o'clock position fit the Bearing into the Concealing Plate.
8. Make sure that the Hub is positioned fully clockwise and refit the Control Lever with the Grubscrew at the bottom, retighten the Grubscrew and refit the Control Lever Handle.
9. Before using the Shower, refer to section: '**Commissioning**'.

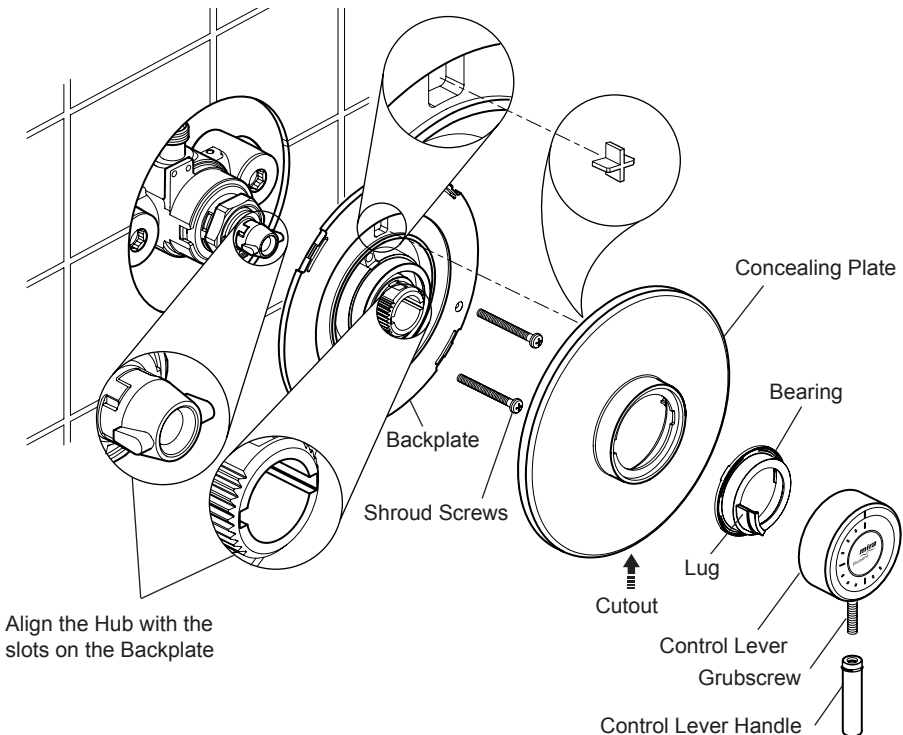

# REVERSED INLET SUPPLIES

The Mira Element Thermostatic Mixer is supplied with inlet connections **Hot - Left, Cold - Right** as standard. If the hot and cold water supply pipes have been reversed during installation the Thermostatic Cartridge must be removed and rotated 180°.

1. Isolate the hot and cold water supplies.
2. Unscrew and remove the Control Lever Handle.
3. Loosen the Grubscrew (by approximately 4 turns) and pull off the Control Lever and Bearing.
4. **Built-in Models Only:**
  - 4.1 Carefully unclip the Concealing Plate from the Backplate.  
**Note!** Use a screwdriver in the cutout to assist separation.
  - 4.2 Unscrew the two Shroud Screws and remove the Backplate from the Mixer.
5. Fit the 'O' Key (supplied) onto the Cartridge Nut and turn anticlockwise. Unscrew fully and pull the Cartridge from the Mixer Body.
6. Rotate the Cartridge 180°.
7. Make sure that the two Cartridge Inlet Seals are fitted and carefully push into the Body, aligning the Cartridge Lugs into the Body Slots.  
**Note!** Check that the Cartridge Lug stamped 'H' is aligned with the hot inlet supply.  
**Important!** Take care when fitting the Cartridge as damage to the Cartridge Inlet Seals may result in dripping from the Shower Head.
8. Tighten the Nut by turning the 'O' Key clockwise.
9. **Built-in Models Only:** Refer to section: '**Control Assembly (Built-in Models)**' and follow instructions 4 to 9.
10. With the lug in the 8 o'clock position fit the Bearing into the Concealing Plate (refer to illustration).
11. Make sure that the Hub is positioned fully clockwise and refit the Control Lever with the Grubscrew at the bottom, retighten the Grubscrew and refit the Control Lever Handle.
12. Before using the Shower, refer to section: '**Commissioning**'.

## Built-in Models

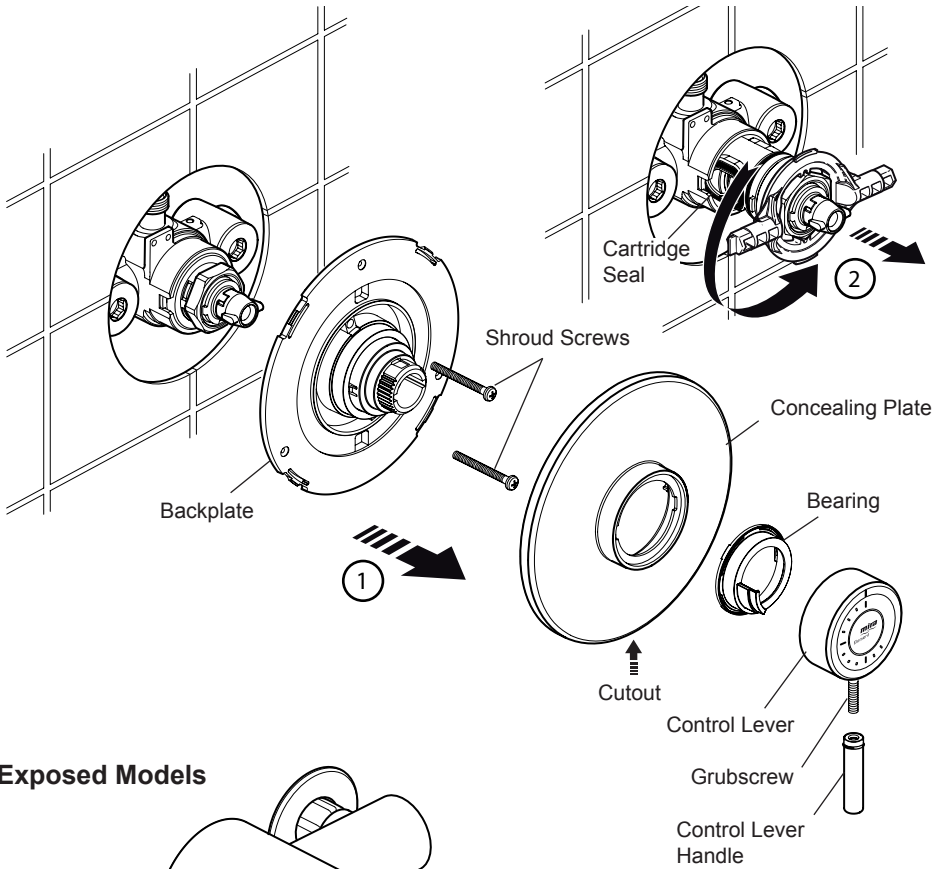

## Exposed Models

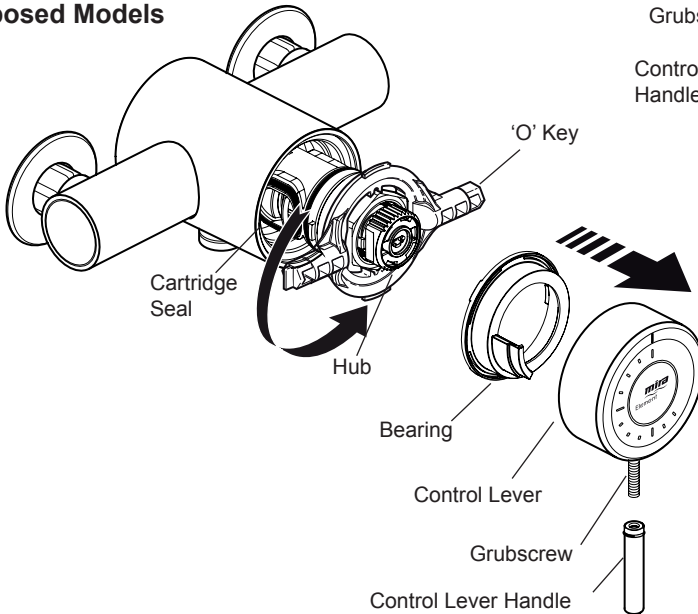

# COMMISSIONING

## Maximum Temperature Setting

Before using the Shower the maximum temperature must be checked to make sure that it is at a safe level. It has been preset to approximately 43°C at the factory but due to variations in site conditions the maximum temperature may need adjustment.

**Note!** Make sure that the hot water temperature is at least 55°C and that there is sufficient supply.

For Type 2 installations the maximum blend temperature is determined by the application, refer to section: '**Type 2 Valves - Application**'.

1. Turn on the Mixer to the maximum temperature (i.e. fully anticlockwise) and allow the temperature to stabilise.

If the temperature is too hot or too cold adjust as follows:

2. Carefully unclip the Concealing Cap.  
**Caution!** Take care not to damage the chrome surface.
3. Unscrew the Hub Retaining Screw with a 2.5 mm Hexagon Key.
4. Insert the 2.5 mm Hexagon Key into the centre of the Spindle and engage with the recessed Temperature Adjusting Screw.
5. Rotate the Hexagon Key until the required maximum temperature is obtained at the Shower. Anticlockwise to increase the temperature, or clockwise to decrease the temperature ( $\frac{1}{4}$  turn = approximately 1°C).
6. Once the desired maximum blend temperature has been achieved turn off the Mixer.
7. Refit the Hub Retaining Screw.
8. With the cutout in the 8 o'clock position refit the Concealing Cap.
9. Check that the Shower temperature is correct.

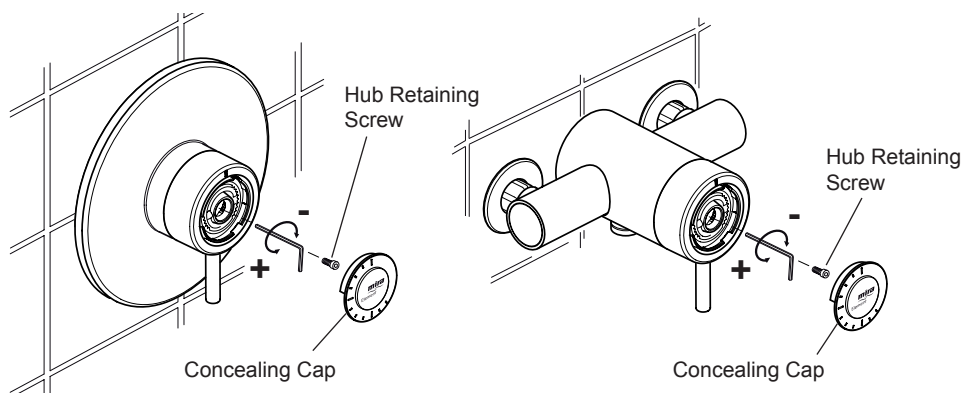

# OPERATION

The Mira Element Thermostatic Mixer is a Thermostatic Shower Control with a Single Sequential Control Lever for on/off and temperature control.

The Control Lever operates anti-clockwise in the following sequence:

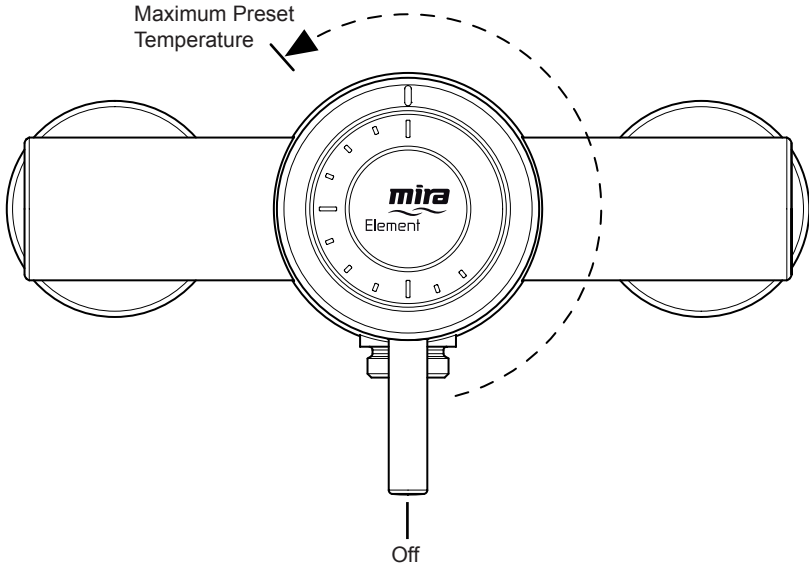

Off ➡ On ➡ Cold ➡ Warm ➡ Maximum Preset Temperature

# FAULT DIAGNOSIS

Symptom	Cause / Rectification
1. Only hot or cold water from the Mixer outlet.	<ul style="list-style-type: none"> <li>a. Inlets reversed (hot supply to cold supply). Refer to section: <b>'Reversed Supplies'</b>.</li> <li>b. No hot water reaching the Mixer.</li> <li>c. Check the Filters for any blockage <b>'Maintenance'</b>.</li> <li>d. Installation conditions outside operating parameters: refer to sections: <b>'Specifications'</b> and <b>'Commissioning'</b>.</li> </ul>
2. Fluctuating or reduced flow rate.	<ul style="list-style-type: none"> <li>a. Check the Showerhead, Hose and Filters for any blockage.</li> <li>b. Make sure the maintained inlet pressures are nominally balanced and sufficient, refer to section: <b>'Specifications'</b>.</li> <li>c. Make sure the inlet temperature differentials are sufficient, refer to section: <b>'Specifications'</b>.</li> <li>d. Flow Regulator fitted incorrectly.</li> <li>e. Airlock or partial blockage in pipework.</li> </ul>
3. No flow from the Mixer outlet.	<ul style="list-style-type: none"> <li>a. Check the Showerhead, Hose and Filters for any blockage.</li> <li>b. Hot or cold supply failure.</li> </ul>
4. Blend temperature drift.	<ul style="list-style-type: none"> <li>a. Refer to symptom 2. above.</li> <li>b. Significant supply temperature fluctuation.</li> <li>c. Significant supply pressure fluctuation.</li> <li>d. Faulty Thermostatic Cartridge, renew.</li> </ul>
5. Maximum blend temperature setting too hot or too cold.	<ul style="list-style-type: none"> <li>a. Indicates incorrect maximum temperature setting; refer to section: <b>'Commissioning'</b>. <b>If the temperature is too cold and you have a combination type boiler it may not be producing sufficiently hot water at desired flow rate (refer to 'Specifications'). Fit flow regulator (supplied) to shower valve outlet. For more information contact Mira Showers or visit the website.</b></li> <li>b. Refer to symptom 4. above.</li> </ul>
6. Water leaking from the Showerhead.	<ul style="list-style-type: none"> <li>a. Normal for a short period after shut off.</li> <li>b. Check that the pressures are not in excess of the specifications for product.</li> <li>c. Cartridge Inlet Seals damaged, renew.</li> <li>d. Renew the Thermostatic Cartridge.</li> </ul>



<p>7. Flow rate too low or too high.</p>	<p>a. (low) Insufficient supply pressures.  b. (high) Supply pressure too high. Install Flow Reg.  c. Refer to symptom <b>2.</b> above.</p>
--	---

## MAINTENANCE

### General

This Product is precision engineered and should give continued safe and controlled performance, provided:

1. It is installed, commissioned, operated and maintained in accordance with manufacturers recommendations.
2. Periodic attention is given, when necessary, to maintain the product in good functional order.

The Mira Element Thermostatic Mixer is designed for the minimum of maintenance in normal use. The only serviceable parts are the inlet filters which should be checked and cleaned every 12 months. If a malfunction occurs with the Thermostatic Cartridge then this will necessitate a complete cartridge replacement.

**Note!** The cartridge contains no internally serviceable parts.

If you require a Mira trained engineer or agent, refer to section: ‘**Customer service**’.

### Lubricants

Silicone based lubricants must only be used on the rubber seals.

**Caution!** Oil based or other lubricant types may cause rapid deterioration of seals.

### Cleaning

The chrome plated parts should be cleaned using a mild washing up detergent or soap solution, rinsed and then wiped dry with a soft cloth.

**Warning!** Many household cleaners contain abrasive and chemical substances, and should not be used for cleaning plated or plastic fittings.

**Do not** use descalents on this product.

### In-service Tests

The principal means for determining the continuing satisfactory performance of the mixing valve is the in-service test.

Follow the procedure detailed in the flow diagram “In-service Test Procedure”.

### Frequency of In-service Tests

#### Commercial (non-domestic installations)

Check for correct blend setting every 6 months.

Follow the procedure detailed in the flow diagram “In-service Test Procedure”, every 12 months.

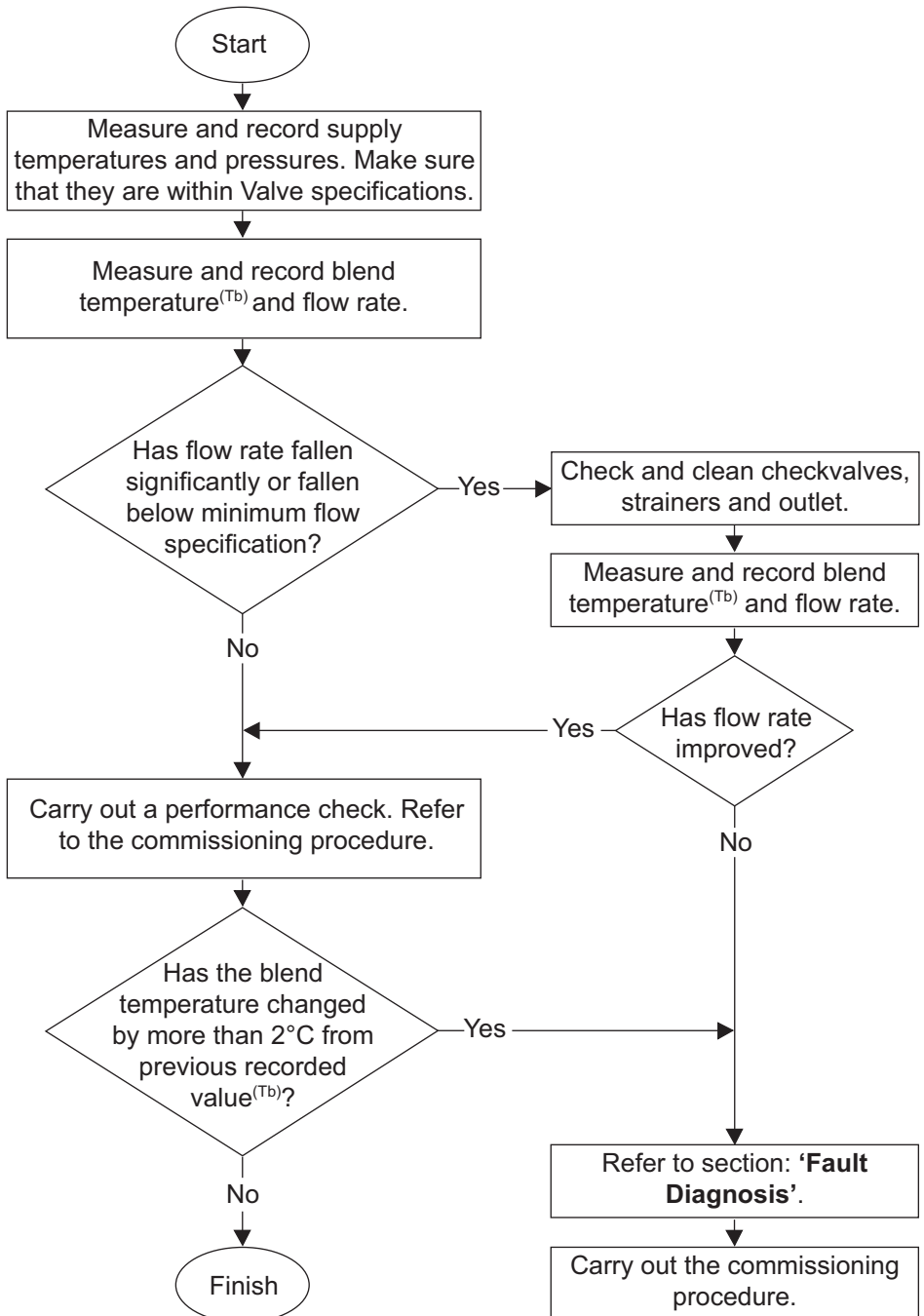

**Note!** All measurements and results should be recorded in the Log Book.

**Flow Diagram, In-service Test Procedure**

## Inlet Filters

The Inlet Filters should be checked and cleaned as necessary every 12 months.

**Note!** The Inlet Filters must not be removed except for cleaning. If the Thermostatic Mixer is operated without the Inlet Filters fitted the Warranty on the product will be void.

### Exposed Models

1. Isolate the hot and cold water supplies and operate the Control Lever to drain any residual water.
  2. Carefully remove the Filter Blanking Caps and unscrew the Filter Caps with the 'O Key' (supplied) or a 12 mm hexagonal wrench and remove the Filters.
  3. Clean the filters under a jet of water to remove any lodged particles.
  4. Refit the Filters and tighten the Filter Caps.
- Note!** Make sure that the 'O' seal is fitted correctly and not damaged.
5. Turn on the hot and cold water supplies and check for leaks.
  6. Refit the Filter Blanking Caps.

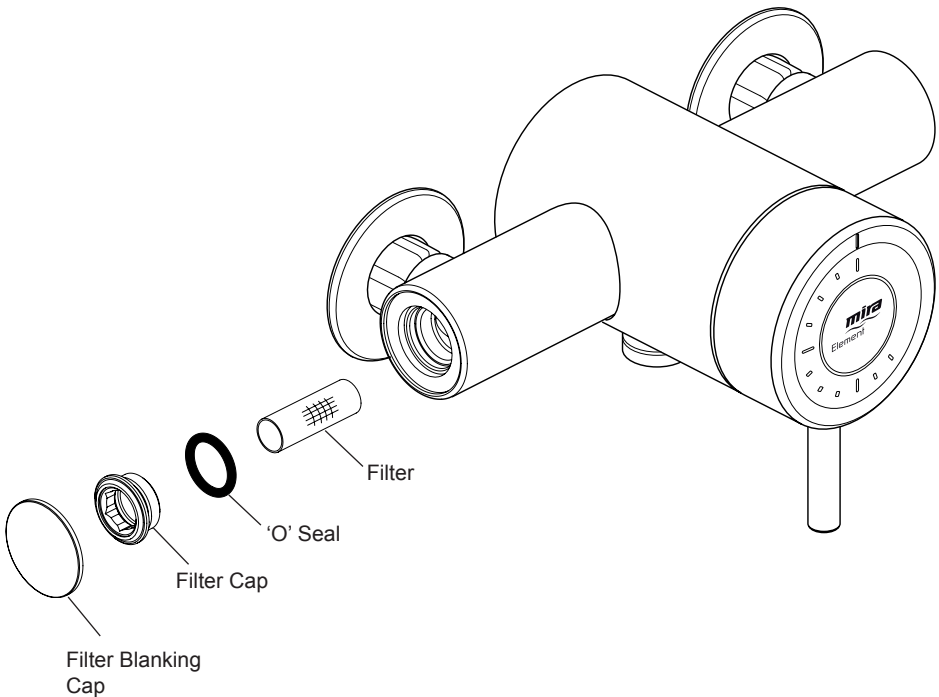

## Built-in Models

**Note!** Refer to illustrations in section: '**Control Assembly (Built-in Models)**'.

1. Isolate the hot and cold water supplies and operate the Control Lever to drain any residual water.
2. Unscrew the Control Lever Handle, loosen the Grubscrew and pull off the Control Lever and Bearing.
3. Carefully unclip the Concealing Plate from the Backplate.  
**Note!** Use a screwdriver in the cutout to assist separation.
4. Unscrew the two Shroud Screws and remove the Backplate from the Mixer.

5. Unscrew the Filter Caps with the 'O Key' (supplied) or a 12 mm hexagonal wrench and remove the Filters.

**Note!** Use pliers to carefully remove the filters.

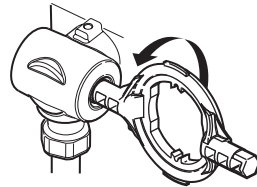

6. Clean each of the filters under a jet of water to remove any lodged particles.

7. Refit the Filters and tighten the Filter Caps.

**Note!** Make sure that the seal is fitted correctly and not damaged.

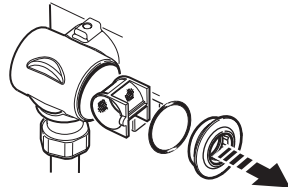

8. Turn on the hot and cold water supplies and check for leaks.
9. Refer to section: '**Control Assembly (Built-in Models)**' and follow instructions 4 to 9.

# TYPE 2 VALVES

## Application

The approved designations for Type 2 Valves are as follows:

Model	Designation
Mira Element	LP-S, HP-S

The permitted application details are:

Designation	Operating Pressure Range	Application	Mixed Water Temperature <sup>†</sup> °C
LP-S	Low Pressure	Shower	41°C Maximum
HP-S	High Pressure	Shower	41°C Maximum

<sup>†</sup> Mixed water temperature at discharge point.

**Important!** For TMV2 installations the mixed water temperature at the discharge point should never exceed 46°C.

In order to achieve the safe water temperatures expected of a Type 2 Valve it is essential that the valve is used only for the applications covered by its approved designations, with the appropriate water supply pressures and temperatures, and it is commissioned, maintained and serviced in accordance with the recommendations contained in this guide (refer to the section '**Maintenance, In-Service Tests**' for in service test frequency that must be used as a minimum guide in Type 2 installations).

## Supply Conditions

For applications where a Type 2 Valve is required, the supply conditions must comply with the values in the Table below. Note that both hot and cold supply pressures must lie within the same pressure range.

Operating Pressure Range	High Pressure	Low Pressure
Maximum Static Pressure (bar)	10	10
Maintained Pressure, Hot and Cold (bar)	1 to 5	0.2 to 1
Hot Supply Temperature (°C)	55 to 65	55 to 65
Cold Supply Temperature (°C)	≤ 25	≤ 25

Valves operating outside these conditions cannot be guaranteed to operate as Type 2 Valves.

# SPARE PARTS

## Exposed Element Thermostatic Mixer

1062470	Seal Pack (identified 'A')
1062471	Component Pack
1062472	Elbow Cap
1062473	Elbow Assembly
1062474	Cartridge Assembly
1062476	Backplate
1062477	Filter Pack (x 2)
1062478	Elbow Connector Pack
1062479	Outlet Connector Pack
1063660	Screw Pack (identified 'B')
1063661	Inlet Connector Pack
1063662	Bearing
1063671	'O' Key
1617.162	Control Lever Pack
1617.163	Control Lever Handle
1617.164	Trim Pack
1617.196	Hub Pack

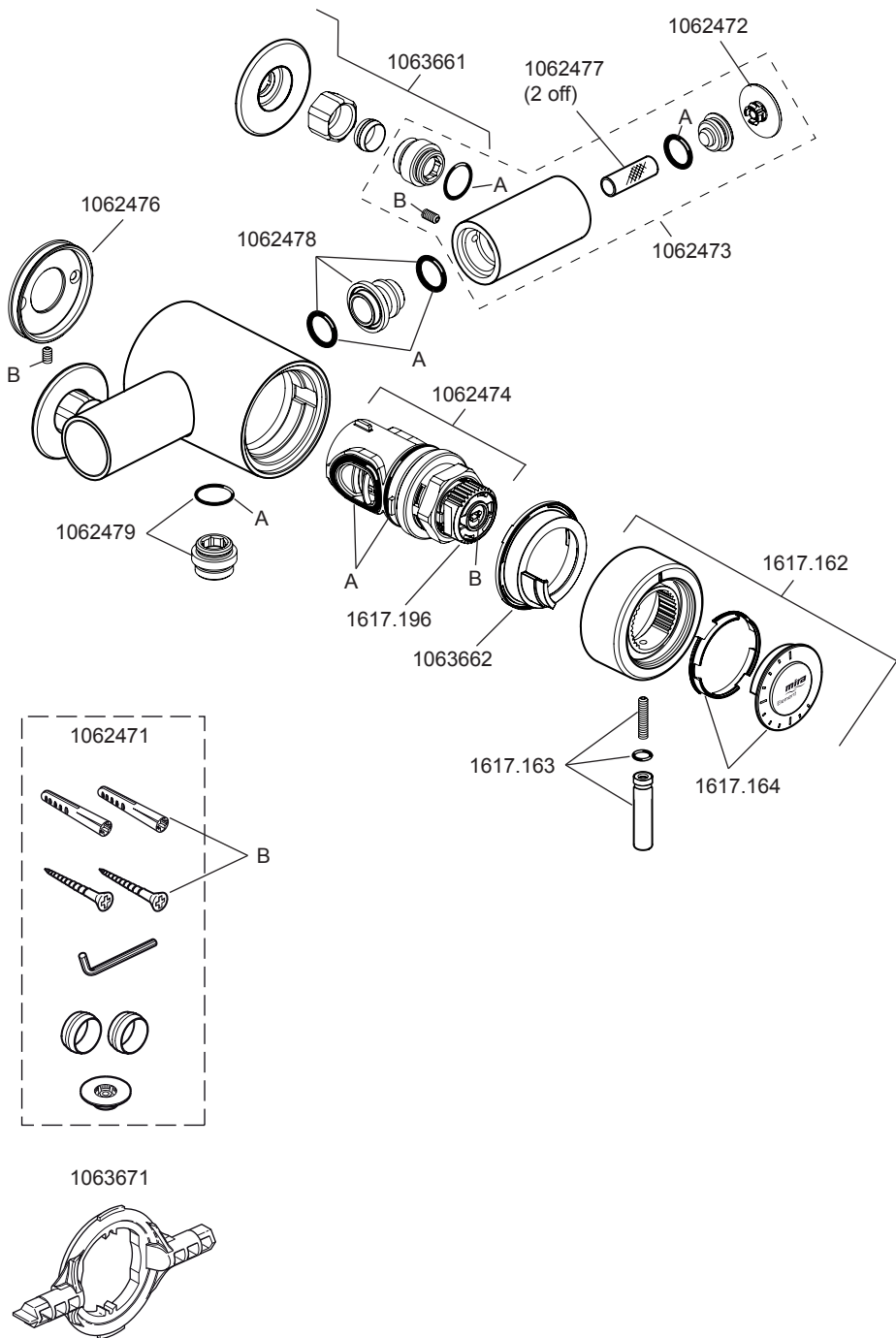

## **Built-in Element Thermostatic Mixer**

1062474	Cartridge Assembly
1063662	Bearing
1063671	'O' Key
1595.046	Seal Pack (identified 'A')
1595.066	Filter Pack (x 2)
1595.067	Screw Pack (identified 'B')
1595.149	Outlet Connector Pack
1595.150	Elbow Assembly
1595.070	Component Pack
1617.162	Control Lever Pack
1617.163	Control Lever Handle
1617.164	Trim Pack
1617.168	Concealing Plate Assembly
1617.196	Hub



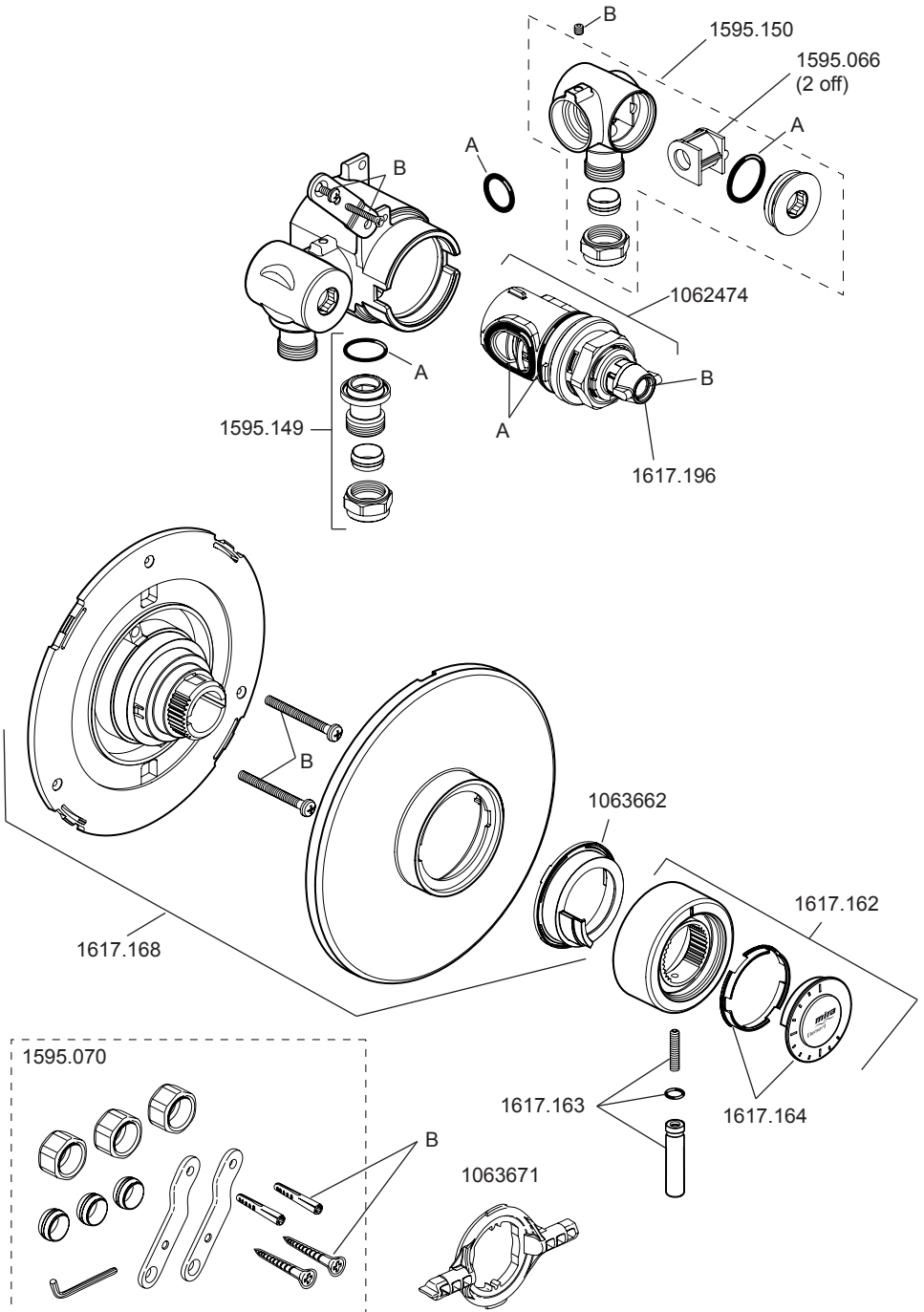

# ACCESSORIES

Genuine Mira accessories can be purchased direct from Customers Services (our contact details can be found on the back cover of this guide) or from approved stockists or merchants.



**Eco Showerhead**  
White - 2.1668.001  
Chrome - 2.1668.002

The Eco shower head gives you an invigorating shower, but reduces water consumption and heating costs.

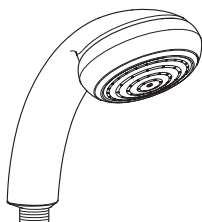

**Everclear Showerhead**  
White - 2.1616.030  
Chrome - 2.1616.031

Mira's new Everclear range has been specially designed for hard water areas and reduces the risk of lime scale build up.

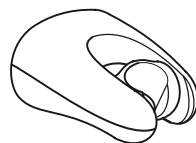

**Logic Showerhead Holder**  
White - 2.1605.149  
White/Chrome - 2.1605.150

An alternative to the traditional slide bar. Often a useful addition when positioned for the smaller members of the family.



**Wall Mounted Soap Dish**  
White - 1.1540.278  
Chrome - 1.1540.279

Wall mounted for use anywhere in, or outside the showering area.

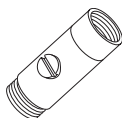

**Double Outlet Check Valve (DCV-H)**  
Chrome - 1.0.110.55.1

An outlet double check valve, designed to prevent the back flow or back-siphonage of potentially contaminated water, through shower controls which are fitted with a flexible shower hose as part of the outlet shower fitting.

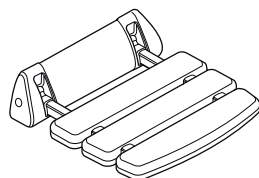

**Shower Seat**  
White - 2.1536.128  
White/Chrome - 2.1536.129

For use in or out of the showering area. Folds up when not in use. Maximum User Weight - 127 kg (20 stone) **Note!** Must be installed onto a solid wall.



**Premium Shower Seat**  
White/Chrome - 2.1731.001  
Grey/Chrome - 2.1731.002

Stylish, slim-line and robust shower seat for use in or outside of the shower area. Folds up when not in use. Maximum User Weight - 150 kg (23.5 stone) **Note!** Must be installed onto a solid wall.

# NOTES

# CUSTOMER SERVICE

## Guarantee

Your product has the benefit of our manufacturer's guarantee which starts from the date of purchase.

To activate this guarantee, please return your completed registration card, visit our website or free phone 0800 0731248 within 30 days of purchase (UK only).

Within the guarantee period we will resolve defects in materials or workmanship, free of charge, by repairing or replacing parts or product as we may choose.

If you have not previously activated the guarantee, you will be required to do so prior to the provision of assistance. If you do not activate your guarantee our Engineer will be entitled to charge full payment for the visit (Call out fee plus parts).

**This guarantee is in addition to your statutory rights and is subject to the following conditions:**

- The product must be installed and maintained in accordance with the instructions given in this user guide.
- Servicing must only be undertaken by us or our appointed representative. **Note!** if a service visit is required the product must be fully installed and connected to services.
- Repair under this guarantee does not extend the original expiry date. The guarantee on any replacement parts or product ends at the original expiry date.
- For shower fittings or consumable items we reserve the right to supply replacement parts only.

**The guarantee does not cover:**

- Call out charges for non product faults (such as damage or performance issues arising from incorrect installation, improper use, lack of maintenance, build up of limescale, frost damage, corrosion, system debris or blocked filters) or where no fault has been found with the product.
- Water or electrical supply, waste and isolation issues.
- Compensation for loss of use of the product or consequential loss of any kind.
- Damage or defects caused if the product is repaired or modified by persons not authorised by us or our appointed representative.
- Routine maintenance or replacement parts to comply with the requirements of the TMV 2 or TMV 3 healthcare schemes.

## What to do if something goes wrong

If your product does not function correctly when you first use it, contact your installer to check that it is installed and commissioned in accordance with the instructions in this manual. Should this not resolve the issue, contact our Customer Services Team who will offer you or your installer advice and if applicable arrange for a Service Technician to call. If the performance of your product declines, check in this manual to see if simple home maintenance is required. If you require further assistance call our Customer Services Team.

## Extended Guarantees

A selection of protection plans are available that enable you to cover repair bills for the life of your policy (excludes Eire). Ring 01922 471763 for more details.

## Helpdesk Service

Our dedicated Customer Services Team is comprehensively trained and can offer help and advice, spare parts, accessories or a service visit. We will need you to have your model name or number, power rating (if applicable) and date of purchase. As part of our quality and training programme calls may be recorded or monitored.

## Mira Showers Website ([www.mirashowers.co.uk](http://www.mirashowers.co.uk))

From our website you can register your guarantee, download additional user guides, diagnose faults, purchase our full range of accessories and popular spares, refer to our FAQ's and request a service visit.

## Spares and Accessories

We maintain extensive stocks of genuine spares and accessories and aim to provide support throughout the product's expected life. Payment can be made by phone at time of order using most major Credit or Debit cards and we aim to despatch orders within two working days. Items purchased from us are guaranteed for 12 months from date of purchase. For safety reasons spares exposed to mains voltages should only be fitted by competent persons.

**Returns** – items can be returned within one month of date of purchase, providing that they are in good condition and the packaging is unopened. Please obtain authorisation from our Customer Services Team before return. We reserve the right to apply a 15% restocking charge.

## Service / Repairs

We have a nationwide team of Service Technicians who can carry out all service or repair work to your product within the guarantee period and beyond. You have the assurance of a fully trained Mira Technician, genuine Mira spare parts and a 12 month guarantee on any chargeable work done.

Payment should be made directly to the Service Technician who will accept most major Credit or Debit cards.

## To Contact Us

### UK

**Telephone: 0844 571 5000**

**[www.mirashowers.co.uk](http://www.mirashowers.co.uk)**

E-mail: [technical@mirashowers.com](mailto:technical@mirashowers.com)

Fax: 01242 282595

By Post: Mira Customer Services Dept, Cromwell Road, Cheltenham, Gloucestershire, GL52 5EP

### Eire

**Telephone: 01 459 1344**

E-mail: [sales@modernplant.ie](mailto:sales@modernplant.ie)

Fax: Dublin 01 459 2329

By Post: Modern Plant Ltd (Dublin), Otter House, Naas Road, Clondalkin, Dublin 22

Mira is a registered trade mark of  
Kohler Mira Limited.

The company reserves the right to alter  
product specifications without notice.



**mira**  
SHOWERS