

# Erbauer®



**ERB380ROU**

**2Year**  
Guarantee

**2100W ROUTER**

Original Instructions  
(Version 2.0)

# Erbauer®

Congratulations on your purchase of a quality power tool from Erbauer (UK) Ltd. This product should give you reliable service but for your peace of mind this **Erbauer** power tool does carry a 2 year guarantee, the terms of which are detailed below.

If this product develops a fault within the guarantee period contact your retailer.

Please retain this handbook in case you need to refer to safety, care or guarantee information in the future.

## GUARANTEE

This **Erbauer** product carries a 2 year guarantee. If your product develops a fault within this period, you should in the first instance contact the retailer where the item was purchased.

This guarantee specifically excludes losses caused due to:

- Fair wear and tear
- Misuse or abuse
- Lack of routine maintenance
- Failure of consumable items (such as batteries)
- Accidental damage
- Cosmetic damage
- Failure to follow manufacturer's guidelines
- Loss of use of the goods

This guarantee does not affect your statutory rights. This guarantee is only valid in the UK.

For further technical advice, spare parts or repair service (outside of guarantee) please contact the customer helpline number on 0345 607 6380.

# 2100W ROUTER

# GENERAL SAFETY INSTRUCTIONS

## **WARNING! Read all safety warnings and all instructions.**

Failure to follow the warnings and instructions may result in electric shock, fire and/or serious injury.

### **Save all warnings and instructions for future reference.**

The term “power tool” in the warnings refers to your mains-operated (corded) power tool or battery-operated (cordless) power tool.

## **1. Work area safety**

- a. Keep work area clean and well lit.** Cluttered or dark areas invite accidents.
- b. Do not operate power tools in explosive atmospheres, such as in the presence of flammable liquids, gases or dust.** Power tools create sparks which may ignite the dust or fumes.
- c. Keep children and bystanders away while operating a power tool.** Distractions can cause you to lose control.

## **2. Electrical safety**

- a. Power tool plugs must match the outlet. Never modify the plug in any way. Do not use any adapter plugs with earthed (grounded) power tools.** Unmodified plugs and matching outlets will reduce risk of electric shock.
- b. Avoid body contact with earthed or grounded surfaces, such as pipes, radiators, ranges and refrigerators.** There is an increased risk of electric shock if your body is earthed or grounded.
- c. Do not expose power tools to rain or wet conditions.** Water entering a power tool will increase the risk of electric shock.
- d. Do not abuse the cord. Never use the cord for carrying, pulling or unplugging the power tool. Keep cord away from heat, oil, sharp edges or moving parts.** Damaged or entangled cords increase the risk of electric shock.
- e. When operating a power tool outdoors, use an extension cord suitable for outdoor use.** Use of a cord suitable for outdoor use reduces the risk of electric shock.
- f. If operating a power tool in a damp location is unavoidable, use a residual current device (RCD) protected supply.** Use of an RCD reduces the risk of electric shock.

### 3. Personal safety

**a. Stay alert, watch what you are doing and use common sense when operating a power tool. Do not use a power tool while you are tired or under the influence of drugs, alcohol or medication.** A moment of inattention while operating power tools may result in serious personal injury.

**b. Use personal protective equipment. Always wear eye protection.** Protective equipment such as dust mask, non-skid safety shoes, hard hat, or hearing protection used for appropriate conditions will reduce personal injuries.

**c. Prevent unintentional starting. Ensure the switch is in the off-position before connecting to power source and/or battery pack, picking up or carrying the tool.** Carrying power tools with your finger on the switch or energising power tools that have the switch on invites accidents.

**d. Remove any adjusting key or wrench before turning the power tool on.**

A wrench or a key left attached to a rotating part of the power tool may result in personal injury.

**e. Do not overreach. Keep proper footing and balance at all times.** This enables better control of the power tool in unexpected situations.

**f. Dress properly. Do not wear loose clothing or jewellery. Keep your hair, clothing and gloves away from moving parts.** Loose clothes, jewellery or long hair can be caught in moving parts.

**g. If devices are provided for the connection of dust extraction and collection facilities, ensure these are connected and properly used.** Use of dust collection can reduce dust-related hazards.

### 4. Power tool use and care

**a. Do not force the power tool.** Use the correct power tool for your application. The correct power tool will do the job better and safer at the rate for which it was designed.

**b. Do not use the power tool if the switch does not turn it on and off.** Any power tool that cannot be controlled with the switch is dangerous and must be repaired.

**c. Disconnect the plug from the power source and/or**

# 2100W ROUTER

**the battery pack from the power tool before making any adjustments, changing accessories, or storing power tools.** Such preventive safety measures reduce the risk of starting the power tool accidentally.

**d. Store idle power tools out of the reach of children and do not allow persons unfamiliar with the power tool or these instructions to operate the power tool.** Power tools are dangerous in the hands of untrained users.

**e. Maintain power tools. Check for misalignment or binding of moving parts, breakage of parts and any other condition that may affect the power tool's operation. If damaged, have the power tool repaired before use.** Many accidents are caused by poorly maintained power tools.

**f. Keep cutting tools sharp and clean.** Properly maintained cutting tools with sharp cutting edges are less likely to bind and are easier to control.

**g. Use the power tool, accessories and tool bits etc. in accordance with these instructions, taking into account the working conditions and the work to be performed.** Use of the power tool for operations different from those intended could result in a hazardous situation.

## **5. Service**

**a) Have your power tool serviced by a qualified repair person using only identical replacement parts.** This will ensure that the safety of the power tool is maintained.

**b) If the replacement of the supply cord is necessary, this has to be done by the manufacturer or his agent in order to avoid a safety hazard.**

## **ADDITIONAL SAFETY INSTRUCTIONS FOR YOUR ROUTER**

- 1. Hold tool by insulated gripping surfaces when performing an operation where the cutting tool may contact hidden wiring.** Contact with a "live" wire will make exposed metal parts of the tool "live" and shock the operator.
- 2. Use clamps or another practical way to secure and the workpiece to a stable platform.** Holding the work by hand or

against your body leaves it unstable and may lead to loss of control.

3. Always wear a dust mask.
4. Wear protective glasses and hearing protection.
5. For long hair, wear hair protection. Work only with closely fitting clothes.
6. If the mains cable is damaged or cut through while working, do not touch the cable. Never use the machine with a damaged cable.
7. Do not operate the machine in rain or high moisture conditions.
8. Always direct the cable to the rear away from the machine. Take care with the trailing cable from the router and we recommend that an RCD is used at all times with this machine.
9. Contact with electric lines can lead to fire and electric shock. Damaging a gas line can lead to explosion. Penetrating a water line causes property damage or may cause an electric shock.
10. When working with the machine, always hold it firmly with both hands.
11. Secure the workpiece. A workpiece clamped with clamping devices or in a vice is held more secure than by hand.
12. Before putting into operation, check the routing tool for firm seating.
13. Never route over metal objects such as nails or screws.
14. Keep hands away from rotating router bits.
15. After finishing work, guide the machine back into the upper starting position by actuating the clamping lever and switch the machine off.
16. Always switch the machine off and wait until it has come to a standstill before placing it down.
17. Protect tools from impact and shock.
18. Never allow children to use the machine.
19. **Do not use blunt or damaged router bits.** Blunt or damaged router bits cause increased friction, can become jammed and lead to imbalance.
20. **The allowable speed of the router bit must be at least as high as the maximum speed listed on the power tool.** Accessories that rotate faster than permitted can be destroyed.
21. **Never touch the bit during or immediately after the use.** After use the bit is too hot to be touched by bare hands.

# 2100W ROUTER

 **Warning:** Some dust particles created by power sanding, sawing, grinding, drill and other construction jobs contain chemicals known to cause cancer, birth defects or other reproductive harm. Some examples of these chemicals are:

- Lead from lead-based paints.
- Crystalline silica from bricks and cement and other masonry products.
- Arsenic and chromium from chemically treated timber.

Your risk from these exposures varies, depending upon how often you do this type of work. To reduce your exposure to these chemicals:

- Work in a well-ventilated area.
- Work with approved safety equipment, such as those dust masks that are specially designed to filter microscopic particles.

## VIBRATION

The European Physical Agents (Vibration) Directive has been brought in to help reduce hand arm vibration syndrome injuries to power tool users. The directive requires power tool manufacturers and suppliers to provide indicative vibration test results to enable users to make informed decisions as to the period of time a power tool can be used safely on a daily basis and the choice of tool.

Further Advice can be found at [www.hse.gov.uk](http://www.hse.gov.uk)

Vibration total values (triax vector sum) determined according to EN 60745:	
Typical weighted vibration	Vibration emission value $a_h = 2.5\text{m/s}^2$
	Uncertainty $K = 1.5\text{m/s}^2$

The declared vibration emission value should be used as a minimum level and should be used with the current guidance on vibration.

Calculating the actual period of the actual period off use can be difficult and the HSE website has further information.

The declared vibration emission been measured in accordance with a standardised test stated above and may be used to compare one tool with another tool.

The declared vibration emission value may also be used in a preliminary assessment of exposure.

 **Warning:** The vibration emission value during actual use of the power tool can differ from the declared value depending on the ways in which the tool is used dependant on the following examples and other variations on how the tool is used:-

How the tool is used and the materials being cut or drilled.

The tool being in good condition and well maintained

The use the correct accessory for the tool and ensuring it is sharp and in good condition.

The tightness of the grip on the handles.

And the tool is being used as intended by its design and these instructions.

**While working with this power tool, hand/arm vibrations occur. Adopt the correct working practices in order to reduce the exposure to vibration.**



**This tool may cause hand-arm vibration syndrome if its use is not adequately managed.**

 **Warning:** identify safety measures to protect the operator that are based on an estimation of exposure in the actual conditions of use (taking account of all parts of the operating cycle such as the times when the tool is switched off and when it is running idle in addition to the trigger time). Note The use of other tools will reduce the users' total working period on this tool.

Helping to minimise your vibration exposure risk.

ALWAYS use sharp chisels, drills and blades

Maintain this tool in accordance with these instructions and keep well lubricated (where appropriate)

Avoid using tools in temperatures of 10°C or less

Plan your work schedule to spread any high vibration tool use across a number of days.

### **Health Surveillance**

All employees should be part of an employer's health surveillance scheme to help identify any vibration related diseases at an early stage, prevent disease progression and help employees stay in work.

### **Double insulation**

The tool is double insulated. This means that all the external metal parts are electrically insulated from the mains power supply. This is done by placing insulation barriers between the electrical and mechanical components making it unnecessary for the tool to be earthed.

### **Important note**

Be sure the supply is the same as the voltage given on the rating plate. The tool is fitted with a two-core cable and plug.

Remove the mains plug from socket before carrying out, any adjustment or servicing

# 2100W ROUTER

# SYMBOLS



To reduce the risk of injury, user must read instruction manual



Warning



Double insulation



Wear ear protection



Wear eye protection



Wear dust mask



Waste electrical products should not be disposed of with household waste.  
Please recycle where facilities exist. Check with your Local Authority  
or retailer for recycling advice.

yyWxx Manufacturing date code; Year of manufacturing (20yy) and week of manufacturing (Wxx);

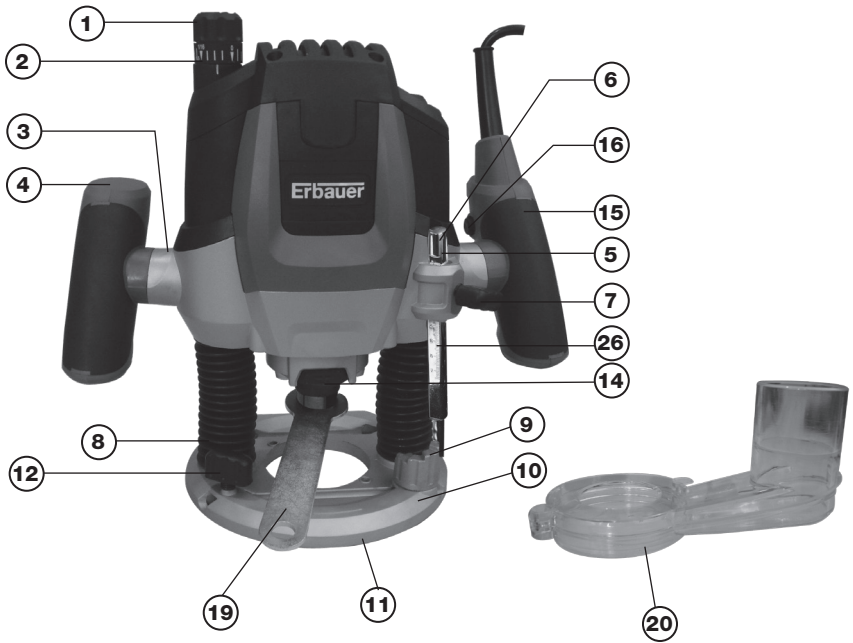

# 2100W ROUTER

- 
1. FINE-ADJUSTMENT KNOB FOR DEPTH-OF-CUT
  2. SCALE FOR FINE ADJUSTMENT OF DEPTH-OF-CUT
  3. CLAMPING LEVER
  4. LEFT HANDLE
  5. SCALE FOR COARSE ADJUSTMENT OF DEPTH-OF-CUT
  6. DEPTH STOP
  7. WING SCREW FOR DEPTH STOP
  8. DUST BOOTS
  9. STEP BUFFER
  10. BASE PLATE
  11. GUIDE PLATE
  12. LOCKING SCREW FOR GUIDE ROD
  13. COLLET NUT
  14. SPINDLE LOCK BUTTON
  15. RIGHT HANDLE (WITH ON/OFF SWITCH)
  16. LOCK-OFF BUTTON
  17. VARIABLE SPEED CONTROL THUMB WHEEL
  18. ON/OFF SWITCH
  19. SPANNER
  20. DUST ADAPTER
  21. PARALLEL GUIDE (SEE FIG 7)
  22. CENTRE PIN (SEE FIG 9)
  23. MARKINGS FOR ZERO-RESET (SEE FIG 4)
  24. GUIDE BUSH (SEE FIG 5)
  25. SCREWS AND NUTS (SEE FIG 2)
  26. INDEX MARK
  27. GUIDE RODS (SEE FIG 9)
  28. WING KNOBS (SEE FIG 9)
  29. ROUTER BIT
  30. EXTRACTION ADAPTER FOR PARALLEL GUIDE (SEE FIG 12-1)
-

## TECHNICAL DATA

Rated voltage	230-240V~50Hz
Rated power	2100W
Rated no-load speed	11500~28000/min
Collet size	1/2" and 1/4"
Max plunge depth	50mm
Double insulation	
Machine weight	4.3Kg

## NOISE DATA

Sound pressure level:	$L_{pA}$ : 90 dB (A)	$K_{pA}$ : 3.0 dB (A)
Sound power level:	$L_{WA}$ : 101 dB (A)	$K_{WA}$ : 3.0 dB (A)
Wear ear protection when sound pressure is over		80dB(A)



## ACCESSORIES

Router mat		1pc
Centre pin		1pc
Parallel guide		1pc
Spanner		1pc
Dust extraction tube		1pc
Dust adapter		1pc
Collet		
	1/4"	1pc
	1/2"	1pc
Template guide (with the nuts and screws provided)		
	30mm	1pc
	16mm	1pc
1/2" router bits		
	Straight bit	1pc
	V Groove bit	1pc
	Round over bit	1pc

# 2100W ROUTER

# OPERATION INSTRUCTIONS



**NOTE:** Before using the tool, read the instruction book carefully.

## INTENDED USE

The machine is intended for routing grooves, edges, profiles and elongated holes as well as for copy routing in wood, plastic and light building materials, while resting firmly on the workpiece.

## 1. INSERTING AND REMOVING THE ROUTER BITS

### Router Bit Selection

Depending on processing and application, router bits are available in many different designs and qualities:







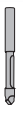
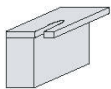

**Router bits made of high-speed steel (HSS)** are suitable for the machining of soft materials, e. g. softwood and plastic.

**Carbide tipped router bits (HM)** are particularly suitable for hard and abrasive materials, e. g. hard wood and aluminium.

**TCT (Tungsten Carbide Tipped)** - for use on hardwood, chipboard, plastics or aluminium.

The most commonly used bits are listed below.

**⚠ Warning: Use only routing tools with an allowable speed matching at least the highest no load speed of the machine. The shank diameter of the router bit must correspond with the rated diameter of the collet. Never use router bits with a diameter exceeding the diameter of the collects.**

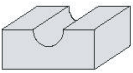
1		Panel Pilot Bit With Drill Point 
2		Straight Bit 
3		V Grooving Bit 
4		Dovetail Bit 
5		Cove Box Bit 

### Inserting Router Bits (See Fig 1)

**Always disconnect the mains plug when fitting router bits and accessories. It is recommended to wear protective gloves when inserting or replacing router bits.**

Press spindle lock button (14) and keep depressed. If required, turn the spindle by hand until the lock engages.

Press the spindle lock button only when at a standstill.

Using the 22 mm spanner (19), loosen the collet nut (13) a few turns and insert a router bit. The shank of the router bit must be inserted at least 20 mm (shank length) or at least as far as the 'K' mark on

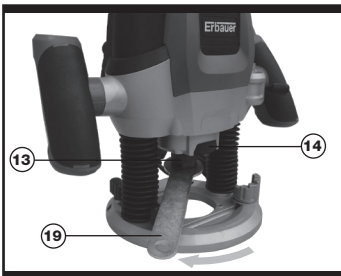

Fig 1

the shank (where marked).

Tighten the collet nut (13) with the spanner (19).

Release the spindle lock button.

**Warning:** Do not tighten the collet nut (13) without a router bit inserted.

### HOW TO FIT THE 1/4" COLLET (See Fig a)

Your router is supplied with a 1/2" collet fitted to the tool. Another 1/4" collet is supplied as an accessory.

**IMPORTANT** - do not remove the 1/2" collet before fitting the 1/4" collet.

To fit the 1/4" collet (b) simply slide it into the 1/2" collet (a) fitted to the collet nut.

The 1/4" collet has a flange collar to ensure insertion to correct depth.

**NOTE:** 1. Do not attempt to remove the 1/2" collet from the collet nut.

2. Always wear safety gloves when changing the router bits.

### 2. MOUNTING THE DUST ADAPTER (See Fig 2)

To connect the vacuum cleaner via a suction hose, you must fasten the dust adapter (20) to the base plate (10) with both screws and nuts (25).

**Warning:** When mounting the extraction adapter, ensure correct mounting position!

- For dust extraction, the vacuum hose can be connected directly to the extraction adapter.
- Clean the dust adapter (20) regularly to ensure optimum dust adapter at all times.
- The vacuum cleaner must be suitable for the material to be worked.
- When vacuuming dry dust that is especially detrimental to health or carcinogenic, use a special vacuum cleaner.

### 3. SWITCHING ON AND OFF (Fig 3)

To start the machine, actuate the lock-off button (16), then press and hold the On/Off switch (18). To switch off the machine, release the On/Off switch (18).

**For safety reasons the On/Off switch of the machine cannot be locked; it must remain pressed during the entire operation.**

#### Variable Speed Control

The required speed can be pre-selected with the thumb-wheel (17).

1 – 2 = low speed

3 – 4 = medium speed

5 – 6 = high speed

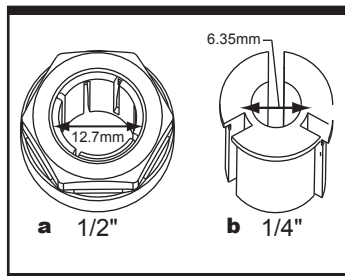

Fig a

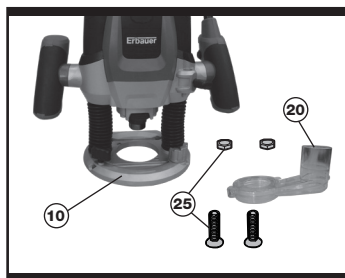

Fig 2

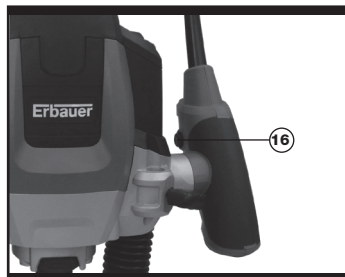

Fig 3

# 2100W ROUTER

The required speed is dependent on the material and can be determined by practical testing. After longer periods of working at low speed, allow the machine to cool down by running it for approx. 3 minutes at maximum speed with no load.

### Speed Table

Material	Router bit-Ø	Speed stages
Hardwood (Beech)	4 – 10 mm	5–6
	12 – 20 mm	3–4
	22 – 40 mm	1–2
Softwood (Pine)	4 – 10 mm	5–6
	12 – 20 mm	3–6
	22 – 40 mm	1–3
Particle board	4 – 10 mm	3–6
	12 – 20 mm	2–4
	22 – 40 mm	1–3
Plastic	4 – 15 mm	2–3
	16 – 40 mm	1–2
Aluminium	4 – 15 mm	1–2
	16 – 40 mm	1

The values shown in the chart are standard values. The necessary speed depends on the material and the operating conditions, and can be determined by practical testing.

### Constant Speed Control and Soft Start

Constant speed control maintains the speed constant at no-load and under most working conditions. Soft start delays the increase in motor speed to reduce the motor “kick” or torque effect to improve operator comfort and safety.

### 4. SETTING THE DEPTH-OF-CUT

Depending on the cutting operation, the depth-of-cut can be preset in several steps.



**Warning:** The adjustment of the depth-of-cut may only be carried out when the router is switched off.

#### Coarse Adjustment of the Depth-of-cut

Place the router on the work-piece to be machined. Set the fine adjustment for depth-of-cut in the centre



position with fine-adjustment knob (1); Turn the fine-adjustment knob until the markings (23) are in alignment as (shown in Fig 4). Afterwards turn scale (2) to "0" (See Fig 4). Set step buffer (9) to the lowest position, the buffer snaps-in noticeably.

Loosen wing screw (7), so that depth stop (6) can be moved freely.

Release the clamping lever (3) by turning in clockwise direction and slowly lower the router until the router bit touches the surface of the workpiece. Lock the router in position by turning the clamping lever in anti-clockwise direction.

Press depth stop downwards until it touches the step buffer (9). Adjust the depth stop (6) to the required routing depth and tighten the wing screw (7). Release the clamping lever and guide the router back up again.

The coarse adjustment of the depth-of-cut should be checked by a trial cut and corrected, if necessary.

### Fine Adjustment of the Depth-of-cut

After a trial cut, fine adjustment can be carried out by turning the fine adjustment knob (1 scale mark = 0.1 mm/1 rotation = 2.0 mm). The maximum adjustment is approx. +/- 8 mm.

**EXAMPLE:** Slide router upwards again and measure the depth-of-cut (set value = 10.0 mm; actual value = 9.8 mm).

Lift up router and position guide plate (11) in such a manner that the router can plunge freely without the router bit touching the work-piece. Lower the router again until the depth stop touches the step buffer (9).

Afterwards set scale (2) to "0".

Loosen wing screw.

With the fine adjustment (1), advance the depth-of-cut in clockwise direction by 0.2 mm/

2 scale marks (= difference between required value and actual value).

Retighten wing screw again.

Slide router upward again and check depth-of-cut by carrying out another trial cut.

After setting the depth-of-cut, the position of the index mark (26), on the depth stop should not be changed anymore so that the currently adjusted setting can always be read off the scale.

## 5. USAGE OF THE STEP BUFFER

a) Dividing the cutting procedure in several steps

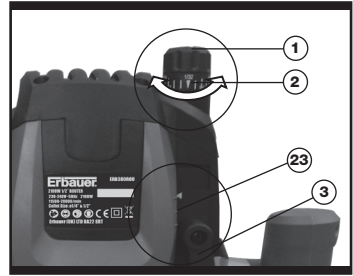

Fig 4

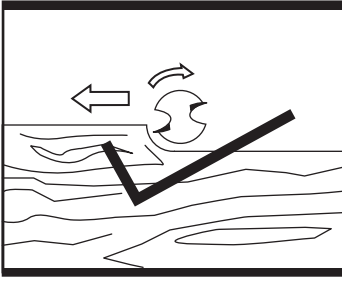

Fig b

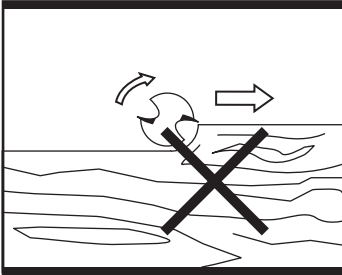

Fig c

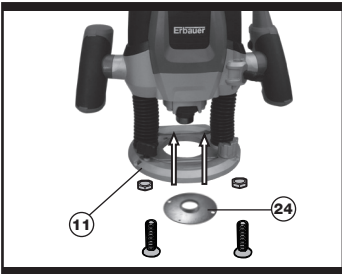

Fig 5

For deep cuts, it is recommended to carry out several cuts, each with less material removal. By using the step buffer, the cutting process can be divided into several steps.

Set the required depth-of-cut with the lowest step of the step buffer. Afterwards, the higher steps can be used for the last two cuts.

#### b) Pre-adjustment of varying depth-of-cuts

If several different depth-of-cuts are required for the machining of a work-piece, these can also be preset by using the step buffer.

### 6. DIRECTION OF FEED (See Fig b, c)

The feed motion of the router must ALWAYS be carried out against the rotation direction of the router bit (See Fig b).

Do not route in the same direction of rotation as the router bit, the router can become loose, preventing control by the user.

### 7. MAKING A CUT

**Note:** Before starting work make sure workpiece is firmly secured.

Place the base plate on the workpiece ensuring that the bit is not in contact with the material to be cut. Switch on the router and allow the bit to reach maximum speed.

Release the clamping lever by turning in clockwise direction and slowly lower the bit into the workpiece surface,

keeping the base plate flush and advancing smoothly until cutting is complete.

Keep the cutting pressure constant, taking care not to overload the router so that the motor speed slows excessively.

### 8. ROUTING WITH GUIDE BUSH (See Fig 6)

**Warning:** Choose a router bit with a smaller diameter than the inner diameter of the guide bush.

The guide bush (24) enables template and pattern routing on work-pieces.

Place the guide bush over the hole in the centre of the base plate, and align the two through holes in the bottom of the base plate with the countersunk holes in the guide bush. Fasten the guide bush with the nuts and screws provided. (See Fig 5).

Set the router with guide bush against the template. Release the clamping lever by turning

in clockwise direction and slowly lower the router toward the work-piece until the adjusted depth of cut is reached.

Guide router with projecting guide bush along the template, applying light sideward pressure.

**NOTE:** The template must have a minimum thickness of 8 mm, due to the projecting height of the guide bush.

## 9. SHAPING OR MOULDING APPLICATIONS

For shaping or molding applications without the use of a parallel guide, the router bit must be equipped with a pilot or a ball bearing.

Lead the router sideward to the workpiece and allow router bit to engage until the pilot or the ball bearing of the router bit reach the corner of the workpiece being machined. Guide the router alongside the workpiece corner using both hands, ensuring proper seating of the base plate. Too much pressure can damage the edge of the workpiece.

## 10. ROUTING WITH PARALLEL GUIDE (See Fig 7, 8)

Slide the parallel guide (21) with the guide rods (27) into the base plate (10) and tighten at the required distance with the locking screw for guide rod (12).

Guide the machine with uniform feed and sideward pressure on the parallel guide (21) along the edge of the workpiece.

## 11. ROUTING CIRCULAR ARC PROFILES (See Fig 9, 10,11)

To reassemble the router guide for use as a circle guide (arc guide), follow below steps:

- Loosen rear wing knobs (28) and fine adjustment knob (A), spacer, and indicator (B), remove these parts from guide rods (C).
- Loosen front knobs and guide base (E), remove from the guide rods.
- Remove springs (D) from guide rods.
- Reinstall fine adjustment guide (F) onto guide rods, rotate 180 degrees from normal position so that circle guide hole faces away from the router.
- Insert the guide rods (C) into router base. For maximum stability, make sure each rod goes through both holes and protrudes out the other side of the router base. At a maximum, the rods must be inserted far enough into the router base to ensure the rods are supported fully by the base when the rods are clamped.

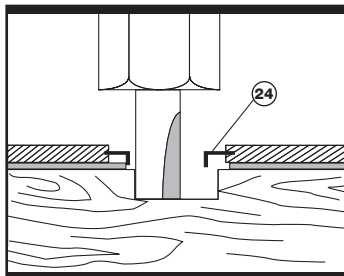

Fig 6

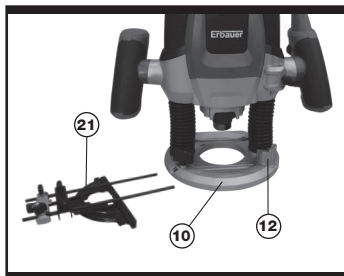

Fig 7



Fig 8

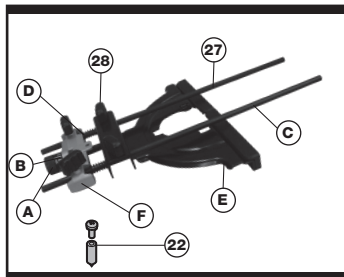

Fig 9

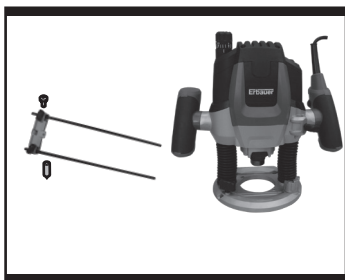

Fig 10

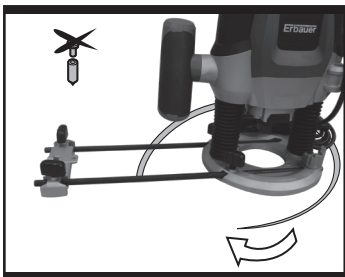

Fig 11

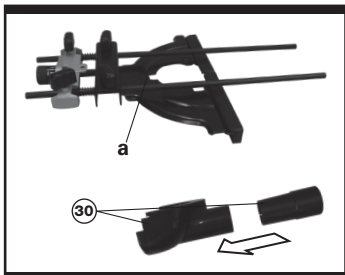

Fig 12-1



Fig 12-2

- Securely fasten the router to the rods by tightening the locking screws (12). The largest circles and arcs can be made when the guide rods enter the side of the router where the locking screws (12) are located.
- Mark the workpiece at the centre of the desired circle.
- Loosen the screw of centre pin (22), and fit into the centre hole of the adjustment guide (F), then fasten the screw to use.
- Place the centre pin against the mark of desired circle on the workpiece.
- Adjust the position of the rods and router as necessary to achieve the desired radius of the circle or arc, then securely tighten wing knobs.

## 12. USING EXTRACTION ADAPTER FOR PARALLEL GUIDE (See Fig 12-1, 12-2)

When the machine routing on an inclination surface, the dust/chip extraction should take place via the special extraction adapter for the parallel guide (30). To mount the extraction adapter for the parallel guide, first insert the tab (a) into place, then engage the front two tabs into place. And then mount the parallel guide with the extraction adapter onto the router.

## MAINTENANCE

Remove the plug from the socket before carrying out any adjustment, servicing or maintenance. Your power tool requires no additional lubrication or maintenance.

There are no user serviceable parts in your power tool. Never use water or chemical cleaners to clean your power tool. Wipe clean with a dry cloth. Always store your power tool in a dry place. Keep the motor ventilation slots clean. Keep all working controls free of dust. Occasionally you may see sparks through the ventilation slots. This is normal and will not damage your power tool.

If the supply cord is damaged, it must be replaced by the manufacturer, its service agent or similarly qualified persons in order to avoid a hazard.

## ENVIRONMENTAL PROTECTION

 Waste electrical products should not be disposed of with household waste. Please  recycle where facilities exist. Check with your Local Authority or retailer for recycling advice. For further information visit [www.recycle-more.co.uk](http://www.recycle-more.co.uk)

## PLUG REPLACEMENT

The fuse in the main plug of your power tool should always be replaced with one of identical rating.

Check the voltage given on your power tool matches the supply voltage.

The power tool is supplied with a fitted plug, however if you should need to fit a new plug follows the instruction below.

### IMPORTANT

The wire in the mains lead are coloured in accordance with the following code:

**Blue ---Neutral**

**Brown ---Live**

The wire that is coloured blue must be connected to the terminal that is marked with the letter **N**.

The wire that is coloured brown must be connected to the terminal that is marked with the letter **L**.

A 13AMP (BS1363 or BS1363/A) plug must be used and a 13 AMP fuse must be fitted.

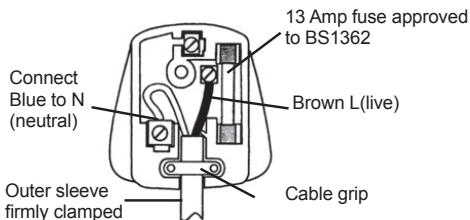

# 2100W ROUTER

# Erbauer®

## DECLARATION OF CONFORMITY

We, Importer  
**Erbauer (UK) Ltd BA22 8RT**

Declare that the product  
Description: **2100W Router**  
Model: **ERB380ROU**

Complies with the following Directives,  
Machinery Directive **2006/42/EC**  
Low Voltage Directive **2006/95/EC**

Electromagnetic Compatibility Directive **2004/108/EC**

Restrictions of the Use of Certain Hazardous Substances in Electrical and Electronic Equipment **2011/65/EU**  
Waste Electrical and Electronic Equipment (WEEE) **2012/19/EU**

Standards and technical specifications referred to:

**EN 55014-1**  
**EN 55014-2**  
**EN 61000-3-2**  
**EN 61000-3-3**  
**EN 60745-1**  
**EN 60745-2-17**

### Authorised Signatory and technical file holder

Date: 10/02/15

Signature: P. C. Harries

Name / title: Peter Harries / Quality Manager  
Erbauer (UK) Ltd. Trade House, Mead Avenue, BA22 8RT









**Erbauer®**