

Robert Bosch GmbH
Power Tools Division
70745 Leinfelden-Echterdingen
Germany

www.bosch-garden.com

F 016 L81 065 (2014.02) 0 / 13 XXX



ART

23-18 LI | 23-18 LI+ | 26-18 LI | 26-18 LI+



en Original instructions



English

Safety Notes

Warning! Read these instructions carefully, be familiar with the controls and the proper use of the machine. Please keep the instructions safe for later use!

Explanation of symbols



General hazard safety alert.



Read instruction manual.



Pay attention that bystanders are not injured through foreign objects thrown from the machine.



Warning: Keep a safe distance from the machine when operating.



Not applicable.



Remove battery before adjusting or cleaning, and before leaving the machine unattended for any period.



Wear eye and ear protection.



Do not work in the rain or leave the trimmer outdoors whilst it is raining.

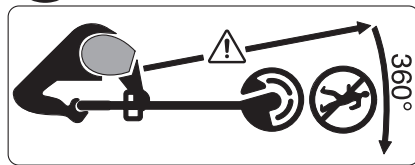

Beware of thrown or flying objects to bystanders.

Warning: Keep a safe distance from the machine when operating.

Operation

- ▶ This machine is not intended for use by persons (including children) with reduced physical, sensory or mental capabilities, or lack of experience and knowledge, unless they have been given supervision or instruction concerning use of the machine by a person responsible for their safety. Children should be supervised to ensure that they do not play with the machine.

- ▶ Never allow children or people unfamiliar with these instructions to use the trimmer. Local regulations may restrict the age of the operator. When not in use, store the trimmer out of reach of children.
- ▶ Never operate the trimmer with missing or broken guards or shields or without guards or shields in position.
- ▶ Before using the machine and after impact, check for signs of wear or damage and repair if necessary.
- ▶ Never operate the product when you are tired, ill or under the influence of alcohol, drugs or medicine.
- ▶ Always wear long heavy trousers, boots and gloves. Do not wear loose clothing, jewellery, short trousers, sandals or go barefoot. Secure hair so that it is above shoulder level to avoid entanglement with moving parts.
- ▶ **Wear safety eye protection and ear defenders when operating the machine.**
- ▶ Keep firm footing and balance. Do not overreach.
- ▶ Never work with this trimmer while people, especially children or pets are nearby.
- ▶ The operator or user is responsible for accidents or hazards occurring to other people or their property.
- ▶ Wait until the blade has completely stopped before touching it. The blade continues to rotate after the trimmer is switched off; a rotating blade can cause injury.
- ▶ Work only in daylight or in good artificial light.
- ▶ Avoid operating the trimmer in bad weather conditions especially when there is a risk of lightning.
- ▶ Operating the trimmer in wet grass decreases the efficiency of performance.
- ▶ Switch off when transporting the trimmer to and from the area to be worked on.
- ▶ Switch on the motor only when the hands and feet are away from the cutting means.
- ▶ Do not put hands or feet near the cutting system.
- ▶ Remove battery before blade change.
- ▶ Never fit metal cutting elements to this trimmer.
- ▶ Inspect and maintain the trimmer regularly.
- ▶ Have the trimmer repaired only by an authorized customer service agent.
- ▶ Always ensure that the ventilation slots are kept clear of debris.
- ▶ Remove the battery:
 - whenever you leave the machine unattended for any period of time
 - before replacing the blade
 - before cleaning or working on the trimmer
- ▶ Store the machine in a secure, dry place out of the reach of children. Do not place other objects on top of the machine.
- ▶ Replace worn or damaged parts for safety.
- ▶ Ensure replacement parts fitted are Bosch approved.
- ▶ **Do not operate the machine without the trimmer attachment fitted.**

Recommendations for Optimal Handling of the Battery

- ▶ **Ensure the switch is in the off position before inserting battery pack.** Inserting the battery pack into machines that have the switch on can cause accidents.
- ▶ **Keep the battery charger away from rain or moisture.** Penetration of water in the battery charger increases the risk of an electric shock.
- ▶ **Recharge only with the charger specified by the manufacturer.** A charger that is suitable for one type of battery pack may create a risk of fire when used with another battery pack.
- ▶ **Do not charge other batteries.** The battery charger is suitable only for charging Bosch lithium ion batteries within the listed voltage range. Otherwise there is danger of fire and explosion.
- ▶ **Keep the battery charger clean.** Contamination can lead to danger of an electric shock.
- ▶ **Before each use, check the battery charger, cable and plug. If damage is detected, do not use the battery charger. Never open the battery charger yourself. Have repairs performed only by a qualified technician and only using original spare parts.** Damaged battery chargers, cables and plugs increase the risk of an electric shock.
- ▶ **Do not operate the battery charger on easily inflammable surfaces (e. g., paper, textiles, etc.) or surroundings.** The heating of the battery charger during the charging process can pose a fire hazard.
- ▶ **Use only Bosch battery packs intended specifically for the machine.** Use of any other battery packs may create a risk of injury and fire.
- ▶ **When battery pack is not in use, keep it away from other metal objects like paper clips, coins, keys, nails, screws, or other small metal objects that can make a connection from one terminal to another.** Shorting the battery terminals together may cause burns or a fire.
- ▶ **Under abusive conditions, liquid may be ejected from the battery; avoid contact. If contact accidentally occurs, flush with water. If liquid contacts eyes, additionally seek medical help.** Liquid ejected from the battery may cause irritations or burns.
- ▶ **Do not open the battery.** Danger of short-circuiting.
- ▶ **Protect the battery against heat, e. g., against continuous intense sunlight, fire, water, and moisture.** Danger of explosion.
- ▶ **Do not short-circuit the battery.** There is danger of explosion.
- ▶ **In case of damage and improper use of the battery, vapours may be emitted. Ventilate the area and seek medical help in case of complaints.** The vapours can irritate the respiratory system.
- ▶ Protect the battery against moisture and water.
- ▶ Store the battery only within a temperature range between 0 °C and 50 °C. As an example, do not leave the battery in the car in summer.

- ▶ Occasionally clean the venting slots of the battery using a soft, clean and dry brush.

Safety Warnings for Battery Chargers



Read all safety warnings and all instructions.

Failure to follow the warnings and instructions may result in electric shock, fire and/or serious injury.

Save all safety warnings and instructions for future reference.



Keep the battery charger away from rain or moisture. Penetration of water in the battery charger increases the risk of an electric shock.







- ▶ **Do not charge other batteries.** The battery charger is suitable only for charging Bosch lithium ion batteries within the listed voltage range. Otherwise there is danger of fire and explosion.
- ▶ **Keep the battery charger clean.** Contamination can lead to danger of an electric shock.
- ▶ **Before each use, check the battery charger, cable and plug. If damage is detected, do not use the battery charger. Never open the battery charger yourself. Have repairs performed only by a qualified technician and only using original spare parts.** Damaged battery chargers, cables and plugs increase the risk of an electric shock.
- ▶ **Do not operate the battery charger on easily inflammable surfaces (e. g., paper, textiles, etc.) or surroundings.** The heating of the battery charger during the charging process can pose a fire hazard.
- ▶ **Supervise children.** This will ensure that children do not play with the charger.
- ▶ **Children or persons that owing to their physical, sensory or mental limitations or to their lack of experience or knowledge, are not capable of securely operating the charger, may only use this charger under supervision or after having been instructed by a responsible person.** Otherwise, there is danger of operating errors and injuries.





Products sold in GB only: Your product is fitted with a BS 1363/A approved electric plug with internal fuse (ASTA approved to BS 1362). If the plug is not suitable for your socket outlets, it should be cut off and an appropriate plug fitted in its place by an authorised customer service agent. The replacement plug should have the same fuse rating as the original plug. The severed plug must be disposed of to avoid a possible shock hazard and should never be inserted into a mains socket elsewhere.

Symbols

The following symbols are important for reading and understanding the operating instructions. Please take note of the symbols and their meaning. The correct interpretation of the symbols will help you to use the garden product in a better and safer manner.

4 | English

Symbol	Meaning
	Wear protective gloves
	Reaction direction
	Movement direction
	Weight
	Switching On
	Switching Off

Symbol	Meaning
	Permitted action
	Prohibited action
	Audible noise
	Accessories/Spare Parts

Intended Use

The machine is intended for the cutting of grass and weeds under bushes, as well as on slopes and edges that can not be reached with the lawn mower.

Intended use is related to operation within 0 °C and 40 °C ambient temperature.

Technical Data

Trimmer		ART 23-18 LI	ART 23-18 LI+	ART 26-18 LI	ART 26-18 LI+
Article number		3 600 HA5 C..	3 600 HA5 C..	3 600 HA5 E..	3 600 HA5 E..
No-load speed	min ⁻¹	7000/8000	7000/8000	7000/8000	7000/8000
Adjustable handle		●	●	●	●
Cutting diameter	cm	23	23	26	26
Weight according to EPTA-Procedure 01/2003	kg	2.4	2.7	2.5	2.8
Battery		Li-Ion	Li-Ion	Li-Ion	Li-Ion
Article number					
- 1.5 Ah		2 607 336 207	2 607 336 207	2 607 336 207	2 607 336 207
- 2.0 Ah		2 607 336 921	2 607 336 921	2 607 336 921	2 607 336 921
Rated voltage	V=	18	18	18	18
Capacity					
- 2 607 336 207	Ah	1.5	1.5	1.5	1.5
- 2 607 336 921	Ah	2.0	2.0	2.0	2.0
Number of battery cells					
- 2 607 336 207		5	5	5	5
- 2 607 336 921		5	5	5	5
Battery Charger		AL 2204 CV	AL 2204 CV	AL 2204 CV	AL 2204 CV
Article number					
EU		2 607 225 273	2 607 225 273	2 607 225 273	2 607 225 273
UK		2 607 225 275	2 607 225 275	2 607 225 275	2 607 225 275
AUS		2 607 225 277	2 607 225 277	2 607 225 277	2 607 225 277
Charging current	A	0.43	0.43	0.43	0.43
Allowable charging temperature range	°C	0 – 45	0 – 45	0 – 45	0 – 45

Please observe the article number on the type plate of your garden product. The trade names of the individual garden products may vary.

Trimmer		ART 23-18 LI	ART 23-18 LI+	ART 26-18 LI	ART 26-18 LI+
Charging time for battery capacity, approx.					
	- 1.5 Ah	min	207	207	207
	- 2.0 Ah	min	290	290	290
Weight according to EPTA-Procedure 01/2003	kg	0.7	0.7	0.7	0.7
Protection class		□/II	□/II	□/II	□/II
Battery Charger		AL 2215 CV	AL 2215 CV	AL 2215 CV	AL 2215 CV
Article number	EU	2 607 225 471	2 607 225 471	2 607 225 471	2 607 225 471
	UK	2 607 225 473	2 607 225 473	2 607 225 473	2 607 225 473
	AUS	2 609 225 475	2 609 225 475	2 609 225 475	2 609 225 475
Charging current	A	1.5	1.5	1.5	1.5
Allowable charging temperature range	°C	0 – 45	0 – 45	0 – 45	0 – 45
Charging time for battery capacity, approx.					
	- 1.5 Ah	min	63	63	63
	- 2.0 Ah	min	85	85	85
Weight according to EPTA-Procedure 01/2003	kg	0.4	0.4	0.4	0.4
Protection class		□/II	□/II	□/II	□/II
Serial number	see type plate on the garden product				
Please observe the article number on the type plate of your garden product. The trade names of the individual garden products may vary.					

Noise/Vibration Information

Measured sound values determined according to EN 60335.		ART 23-18 LI	ART 23-18 LI+	ART 26-18 LI	ART 26-18 LI+
3 600 ...		HA5 C..	HA5 C..	HA5 E..	HA5 E..
Typically the A-weighted noise levels of the product are:					
Sound pressure level	dB(A)	60	60	67	67
Sound power level	dB(A)	81	81	88	88
Uncertainty K	dB	=3	=3	=3	=3
Wear hearing protection!					
Vibration total values (triax vector sum) determined according to EN 60335:					
Vibration emission value a_h	m/s^2	< 2.5	< 2.5	< 2.5	< 2.5
Uncertainty K	m/s^2	= 1.5	= 1.5	= 1.5	= 1.5

6 | English

Declaration of Conformity

	ART 23-18 LI	ART 23-18 LI+	ART 26-18 LI	ART 26-18 LI+
3 600 ...	HA5 C..	HA5 C..	HA5 E..	HA5 E..
We declare under our sole responsibility that the product described under "Technical data" is in conformity with the following standards or standardization documents: EN 60335 according to the provisions of the directives 2011/65/EU, 2004/108/EC, 2006/42/EC, 2000/14/EC. 2000/14/EC: Guaranteed sound power level: Conformity assessment procedure according to Annex V.	dB(A)	88	88	91
			91	91

Equipment category: 33

Notified body:

TÜV Rheinland Intercert Kft., Hungary Nr. 1008

Technical file (2006/42/EC, 2000/14/EC) at:

Bosch Lawn and Garden Ltd., PT-LG/ENS23,
Stowmarket, Suffolk IP14 1EY, England

Henk Becker

Executive Vice President

Engineering

Helmut Heinzelmann

Head of Product Certification

PT/ETM9

Pipa

Henk Becker i.v. Helmut Heinzelmann

Robert Bosch GmbH, Power Tools Division
D-70745 Leinfelden-Echterdingen
15.08.2013

Mounting and Operation

Action	Figure
Delivery Scope	1
Mounting the Cutting Guard	2
Adjusting the Handle	3
Mounting wheels	4
Charging the Battery Pack	
Inserting and Removing the Battery Pack	5
Replace the blade	6
Setting Handle Angle	7
Switching On and Off	8
Working Advice	
Adjusting the Cutting Height	9
Maintenance, Cleaning and Storage	10
Selecting Accessories	11

Starting

For Your Safety

- ▶ **Warning: Switch off and remove battery from machine before adjusting or cleaning.**
- ▶ **The blade continues to rotate for a few seconds after the cordless trimmer is switched off. Allow the motor/blade to stop rotating before switching "on" again.**
- ▶ **Do not rapidly switch off and on.**
- ▶ **Only use Bosch approved cutting elements. Cutting performance will vary with different cutting elements.**

Battery Charging

- ▶ **Do not use other battery chargers.** The supplied battery charger is designed for the Lithium-Ion battery in your garden product.
- ▶ **Observe the mains voltage!** The voltage of the power supply must correspond with the data given on the nameplate of the battery charger. Battery chargers marked with 230 V can also be operated with 220 V.

The battery is equipped with temperature monitoring that allows charging only in the temperature range between 0 °C and 45 °C. In this manner, a high battery service life is achieved.

Note: The battery is supplied partially charged. To ensure full capacity of the battery, completely charge the battery in the battery charger before using your power tool for the first time.

The lithium-ion battery can be charged at any time without reducing its service life. Interrupting the charging procedure does not damage the battery.

The "Electronic Cell Protection (ECP)" protects the lithium ion battery against deep discharging. When the battery is run down or discharged, the garden product is shut off by means of a protective circuit: The blade no longer moves.

⚠ IMPORTANT **Do not continue to press the On/Off switch after the garden product has been automatically switched off.** The battery can be damaged.

Battery charge-control indication

The battery charge-control indicator on the handle of the product will indicate a low charge condition of the battery by flashing three times when the On/Off switch is pressed. If this occurs, please remove the battery and recharge.

Charging Procedure

The charging procedure starts as soon as the mains plug is plugged into the socket and the battery is then inserted into the battery charger .

Due to the intelligent charging method, the charging condition of the battery is automatically detected and the battery is charged with the optimum charging current, depending on battery temperature and voltage.

This gives longer life to the battery and always leaves it fully charged when kept in the charger for storage.

Note: The charging procedure is only possible when the battery temperature is within the allowable charging temperature range, see section "Technical Data".

Flashing Battery Charge Indicator

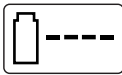

The charging procedure is signalled by a **flashing** battery charge indicator .

Continuous Lighting of the Battery Charge Indicator



Continuous lighting of the battery charge indicator indicates that the battery is fully charged **or** that the temperature of the battery is not within the allowable charging temperature range, and cannot be charged for this reason. The battery is charged as soon as the allowable charging temperature range is reached.

When the battery is not inserted, **continuous lighting** of the battery charge indicator indicates that the mains plug is inserted in the socket and that the battery charger is ready for operation.

Charging Advice

With continuous or several repetitive charging cycles without interruption, the charger can warm up. This is not meaningful and does not indicate a technical defect of the battery charger.

A significantly reduced working period after charging indicates that the battery is used and must be replaced.

Troubleshooting



Problem	Possible Cause	Corrective Action
Blade guard can not be mounted over cutting disc	Incorrect assembly	Remove cutting disc and mount blade guard again
Trimmer fails to operate	Battery discharged	Recharge battery; also see "Battery Charging"
	Battery too hot/cold	Allow to cool/warm
Trimmer runs intermittently	Internal wiring of garden product damaged	Contact Service Agent
	On/Off switch defective	Contact Service Agent
Garden product labours	Grass too high	Cut in stages
Garden product does not cut	Cutting blade damaged	Replace the blade
Increased vibration	Cutting blade damaged	Replace the blade

After-sales Service and Application Service

www.bosch-garden.com

In all correspondence and spare parts orders, please always include the 10-digit article number given on the type plate of the garden product.

8 | English

Great Britain

Robert Bosch Ltd. (B.S.C.)
P.O. Box 98
Broadwater Park
North Orbital Road
Denham
Uxbridge
UB 9 5HJ

At www.bosch-pt.co.uk you can order spare parts or arrange the collection of a product in need of servicing or repair.

Tel. Service: (0844) 7360109

E-Mail: boschservicecentre@bosch.com

Ireland

Origo Ltd.
Unit 23 Magna Drive
Magna Business Park
City West
Dublin 24
Tel. Service: (01) 4666700
Fax: (01) 4666888

Australia, New Zealand and Pacific Islands

Robert Bosch Australia Pty. Ltd.
Power Tools
Locked Bag 66
Clayton South VIC 3169
Customer Contact Center
Inside Australia:
Phone: (01300) 307044
Fax: (01300) 307045
Inside New Zealand:
Phone: (0800) 543353
Fax: (0800) 428570
Outside AU and NZ:
Phone: +61 3 95415555
www.bosch.com.au

Republic of South Africa**Customer service**

Hotline: (011) 6519600

Gauteng – BSC Service Centre

35 Roper Street, New Centre
Johannesburg
Tel.: (011) 4939375
Fax: (011) 4930126
E-Mail: bsctools@icon.co.za

KZN – BSC Service Centre

Unit E, Almar Centre
143 Crompton Street
Pinetown
Tel.: (031) 7012120
Fax: (031) 7012446
E-Mail: bsc.dur@za.bosch.com

Western Cape – BSC Service Centre

Democracy Way, Prosperity Park
Milnerton
Tel.: (021) 5512577
Fax: (021) 5513223
E-Mail: bsc@zsd.co.za

Bosch Headquarters

Midrand, Gauteng
Tel.: (011) 6519600
Fax: (011) 6519880
E-Mail: rbsa-hq.pts@za.bosch.com

Transport

The contained lithium-ion batteries are subject to the Dangerous Goods Legislation requirements. The user can transport the batteries by road without further requirements.

When being transported by third parties (e. g.: air transport or forwarding agency), special requirements on packaging and labelling must be observed. For preparation of the item being shipped, consulting an expert for hazardous material is required.

Dispatch batteries only when the housing is undamaged. Tape or mask off open contacts and pack up the battery in such a manner that it cannot move around in the packaging. Please also observe possibly more detailed national regulations.

Disposal

Do not dispose of garden products, battery chargers and batteries/rechargeable batteries into household waste!

Only for EC countries:

According to the European law 2012/19/EU, electrical and electronic equipments that are no longer usable, and according to the European law 2006/66/EC, defective or used battery packs/batteries, must be collected separately and disposed of in an environmentally correct manner.

Batteries no longer suitable for use can be directly returned at:

Great Britain

Robert Bosch Ltd. (B.S.C.)
P.O. Box 98
Broadwater Park
North Orbital Road
Denham
Uxbridge
UB 9 5HJ

At www.bosch-pt.co.uk you can order spare parts or arrange the collection of a product in need of servicing or repair.

Tel. Service: (0844) 7360109

E-Mail: boschservicecentre@bosch.com

Battery packs/batteries:**Li-ion:**

Please observe the instructions in section "Transport".

Subject to change without notice.

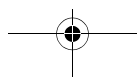
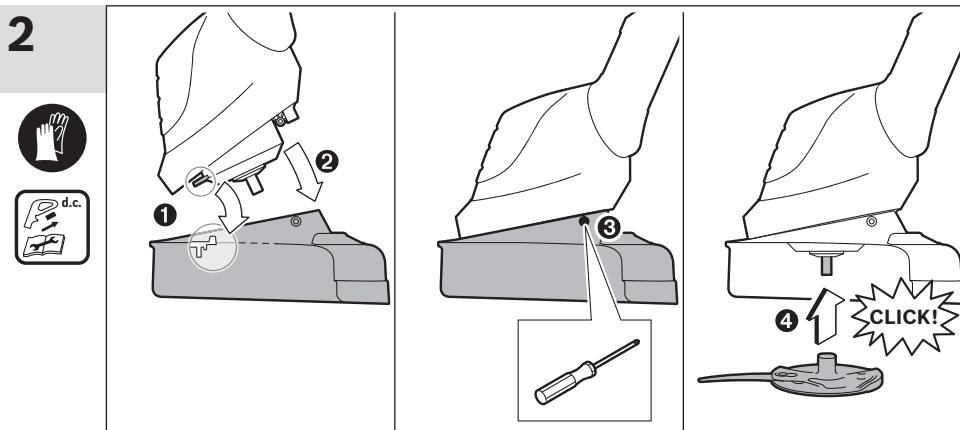
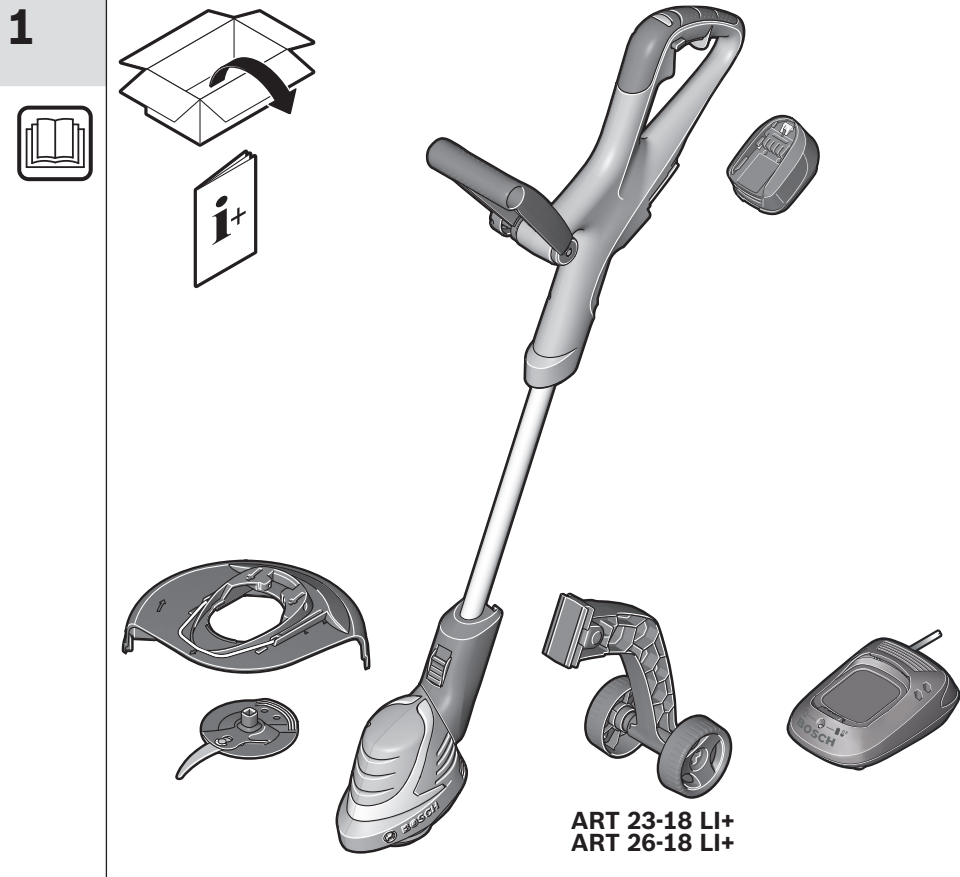



10|



3

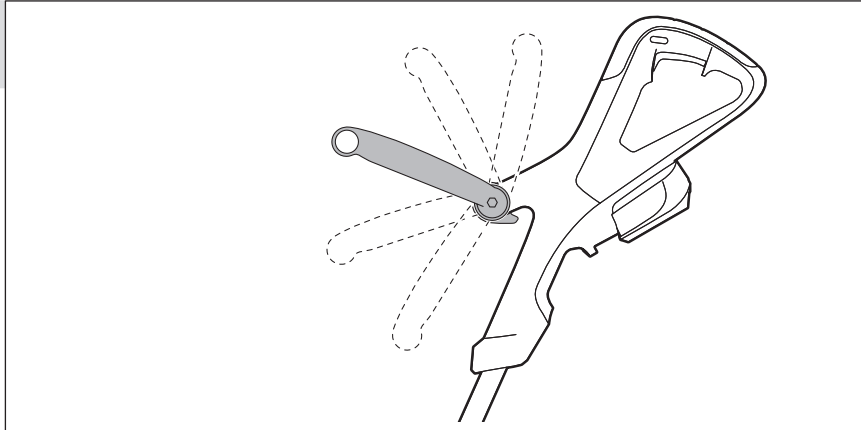

4



ART 23-18 LI+
ART 26-18 LI+

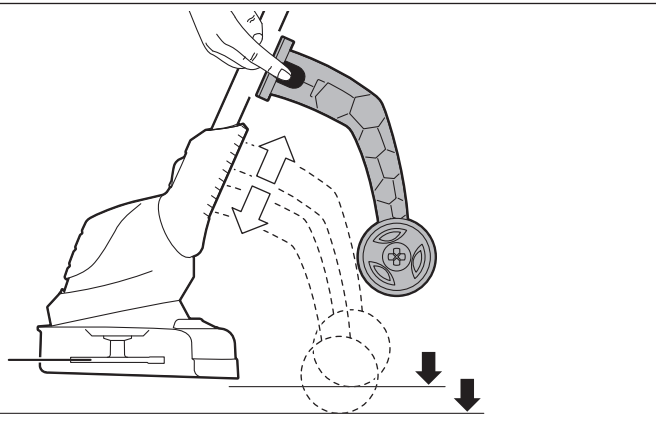

5

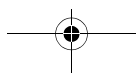
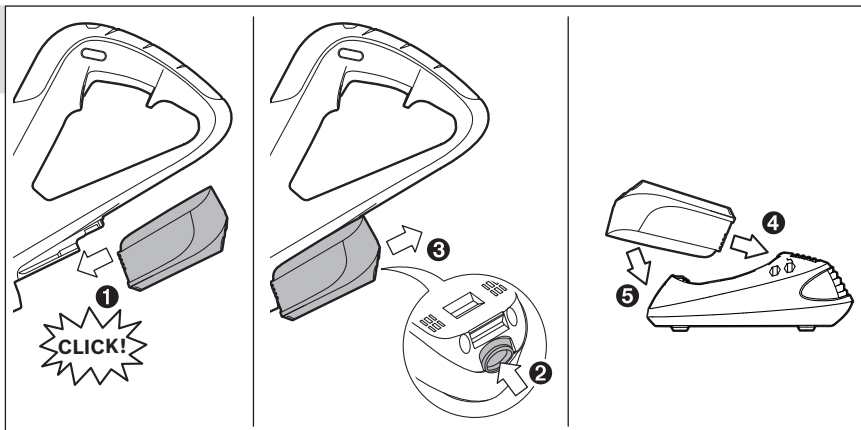

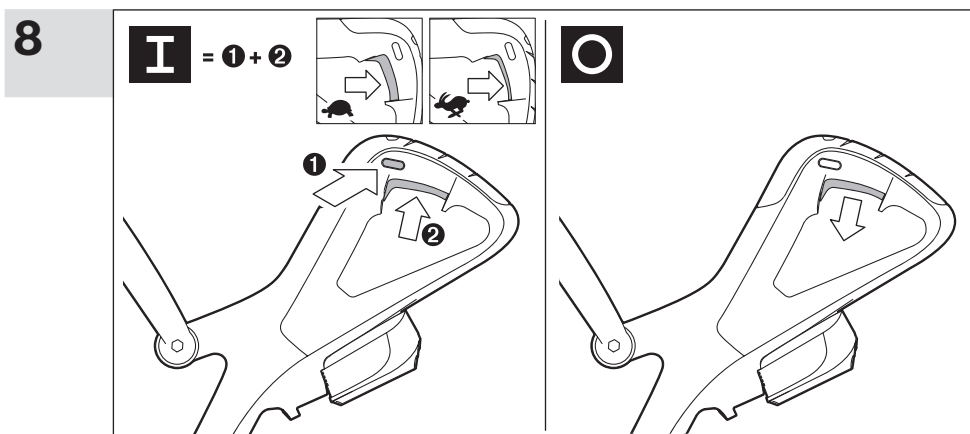
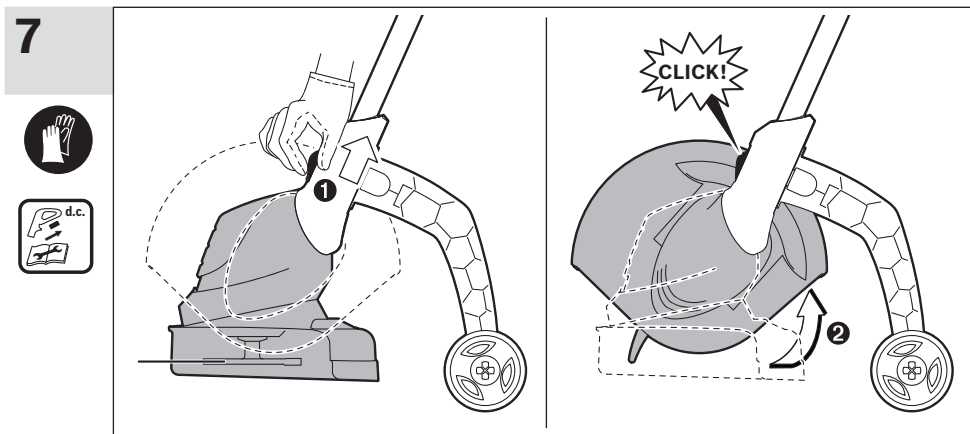
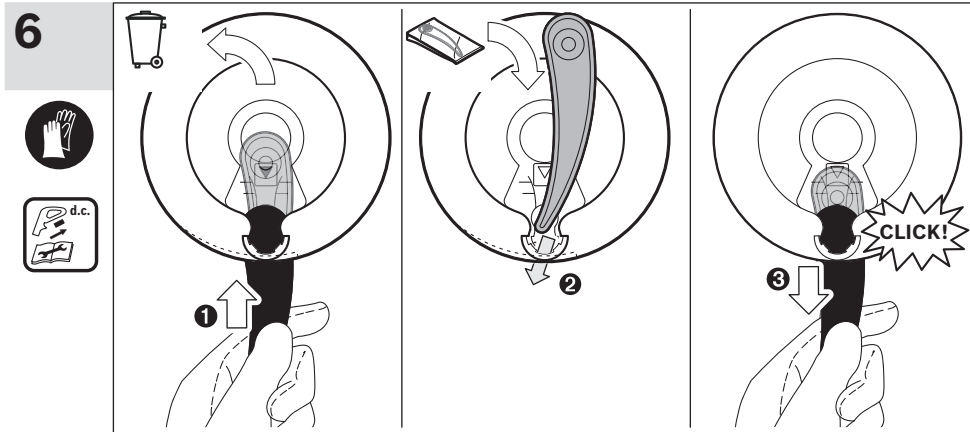

12 |



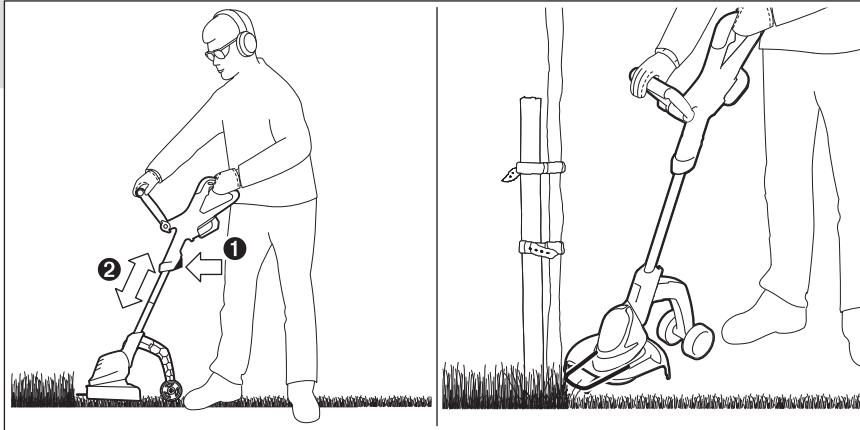

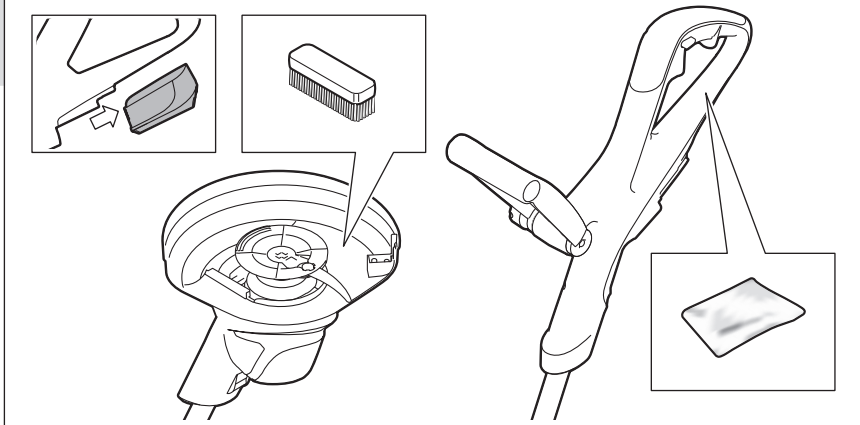

9



10



11

		1 600 Z00 000 (1,5 Ah)
	F 016 800 178	
	ART 23-18 LI/ART 23-18 LI+ F 016 800 371	1 600 Z00 03U (2,0 Ah)
	ART 26-18 LI/ART 26-18 LI+ F 016 800 372	
		1 600 Z00 001 (EU) 1 600 Z00 002 (UK) 1 600 Z00 003 (AUS)