

RECORD POWER
ESTABLISHED 1909®

Original Instruction Manual

BS12

12" Bandsaw

Version 2.0
February 2012



IMPORTANT

For your safety read instructions carefully before assembling or using this product. Save this manual for future reference.

Record Power Ltd
Unit B, Adelphi Way
Staveley S43 3LS

Telephone: 01246 561 520
Fax: 01246 561 537

Email: sales@recordpower.co.uk
www.recordpower.co.uk



Please register this product by logging in at
www.recordpower.co.uk or calling
Record Power on **01246 561 520**

It is important to register your product as soon as possible in order to receive efficient after sales support and be entitled to the full **5 year guarantee**.
Your statutory rights are not affected.

HEALTH AND SAFETY GUIDELINES

Always follow the instructions provided with the manual. Always wear safety glasses when using woodworking equipment. Always disconnect the power before adjusting any equipment. Failure to observe proper safety procedures and guidelines can result in serious injury.

WARNING: Do not allow familiarity (gained from frequent use of your machine and accessories) to become commonplace. Always remember that a careless fraction of a second is sufficient to inflict severe injury.



Always wear safety glasses when using woodworking equipment.



Always read the instructions provided before using woodworking equipment.

Consumable Spare Parts Quick Find

Part Description	Part Number
Blades	
1/4" x 6TPI Bandsaw Blade	BB881406
3/8" x 6TPI Bandsaw Blade	BB883806
1/2" x 4TPI Bandsaw Blade	BB881204
1/2" x 6TPI Bandsaw Blade	BB881206
1/4" x 6TPI Bandsaw Blade	} BB88-3PACK
3/8" x 6TPI Bandsaw Blade	
1/2" x 4TPI Bandsaw Blade	
Custom width & tooth pattern	BB88CUS
Table Insert	114
Bandwheels	
Drive belt	86
Bandwheel tyre	8
Wheel bearing	13
Brush	23
Upper Blade Guides	
Guide roller (side)	118
Guide roller (rear)	36
Lower Blade Guides	
Guide roller (side)	72
Guide roller (rear)	73

Contents

1. Health & Safety Guidance
 2. Additional Health & Safety for 12" Bandsaws
 3. Record Power Guarantee
 4. Getting to Know Your Bandsaw
 5. Specifications
 6. Stand & Wheelkit Assembly
 7. Machine Assembly
 8. Setting Table Square to Sawblade
 9. Bandsaw Blade Set Up
 10. Drive Belt Adjustment & Speed Change
 11. Connection of the Electricity Supply
 12. Operation & Bandsawing Practice
 13. Dust Extraction
 14. Maintenance
 15. Troubleshooting
 16. Parts Lists & Diagrams
- Certificate of Conformity



WARNING: This product is heavy and as a precaution it is advised that two people assemble the machine.

1. Health & Safety Guidance

READ ALL THE INSTRUCTIONS IN THIS MANUAL CAREFULLY BEFORE ASSEMBLY, INSTALLATION AND USE OF THIS PRODUCT. KEEP THESE INSTRUCTIONS IN A SAFE PLACE FOR FUTURE REFERENCE.

WARNING: When using power tools, basic safety precautions should always be followed to reduce the risk of fire, electric shock and personal injury.

SAFE OPERATION

1. Eye Protection

The operation of any power tool can result in foreign objects being thrown into your eyes, which can result in severe eye damage. Always wear safety glasses or other suitable eye protection. Wear safety glasses at all times. Everyday glasses only have impact resistant lenses. They are not safety glasses which give additional lateral protection.

2. Keep Work Area Clear

Cluttered areas and benches invite accidents and injuries.

3. Consider Work Area Environment

- Do not expose the machine to rain or damp conditions.
- Keep the work area well lit.
- Do not use the machine in explosive environments eg. in the presence of flammable liquids, gases or dust.

4. Guard Against Electric Shock

Avoid body contact with earthed or grounded surfaces such as pipes and radiators. There is an increased risk of electric shock if your body is earthed or grounded.

5. Keep Other Persons Away (and Pets)

Do not let persons, especially children, touch the machine, or extension cord (if used) and keep visitors away from the work area.

6. Store Idle Tools

When not in use, tools should be stored in a dry, locked-up place, out of reach of children. Do not allow persons unfamiliar with the tool or these instructions to operate the tool.

7. Do Not Force the Machine

It will do the job better and work more safely if operated within its intended capacities.

8. Use the Right Tool

- Do not use tools for purposes other than those for which they were intended.

9. Dress Properly

- Non-slip footwear is recommended.
- Do not wear loose clothing, neckties or jewellery; they can be caught in moving parts.
- Roll up long sleeves above the elbow.
- Wear protective hair covering to contain long hair.

10. Use Protective Equipment

- Use safety glasses. (See note 1. above)
- Use face or dust shield if cutting operation creates dust.
- Use ear plugs or ear defenders when the machine is in use

11. Connect Dust Extraction Equipment

12. Do Not Abuse the Cord

Never yank the cord to disconnect it from the socket. Keep the cord away from heat, oil and sharp edges. Do not use the cord for carrying the tool.

13. Do Not Overreach

Keep proper footing and balance at all times.

14. Secure Work

Ensure that your work piece is properly held before starting to cut.

15. Maintain Tools With Care.

- Follow instructions for lubrication and changing of accessories and consumables.
- Inspect electric cords periodically and, if damaged, have them repaired by an authorized service facility or qualified electrician.
- The mains plug fitted to the machine should always match the outlet. Do not modify the plug in any way. If a replacement plug is required it should be fitted by a competent person.
- Inspect extension cords (if used) periodically and replace if damaged. Always use properly rated extension cord with a minimum core cross section of 2.5mm² and a maximum length of 3 metres.

16. Keep Cutting Tools Sharp and Clean

Properly maintained cutting tools are easier to control and less likely to bind.

17. Disconnect Machine

When not in use, before servicing, changing blades etc. disconnect the machine from the power supply.

18. Never Leave Machine Running Unattended

Turn power off, do not leave machine until it comes to a complete stop.

19. Remove Adjusting Keys and Wrenches

ENSURE that all adjusting wrenches and keys are removed before switching the machine 'ON'.

20. Avoid Unintentional Starting

Ensure the switch is in the "STOP" position before turning on the power from the main electricity supply. This means the machine will not automatically start up after a power cut or switching on of the mains supply, unless you first reset the start switch.

21. Outdoor Extension Leads

Your machine should not be used outdoors.

22. Damp Conditions

If operating a power tool in damp conditions is unavoidable, a residual current device (RCD) protected supply must be used to reduce the risk of electric shock.

23. Stay Alert

Use power tools with extreme care and do not use the machine when you are tired or under the influence of drugs, alcohol or medication.

24. Check for Damaged Parts

- Before use of the machine, it should be carefully checked to determine that it will operate properly and perform its intended function.
- Check for alignment of moving parts, binding of moving parts, breakage of parts, mounting and any other conditions that may affect its operation.
- A guard or other part that is damaged should be properly repaired or replaced by a qualified person unless otherwise indicated in this instruction manual. Have defective switches replaced by a qualified person.
- Do not use the machine if the switch does not turn on and off.

25. Warning!

- The use of any accessory or attachment, other than those recommended in this instruction manual, or recommended by our Company may present a risk of personal injury.

26. Have Your Machine Repaired by a Qualified Person

- This electric machine complies with the relevant safety rules. Only qualified persons using original spare parts should carry out repairs. Failure to do this may result in considerable danger to the user and invalidation of warranty.

Maintenance and Servicing

This machine requires very little maintenance. This manual gives clear instructions on installation, set up and operation.

Read these instructions carefully. Remember always to switch off and unplug from the main electricity supply before carrying out any setting up or maintenance operations.

2. Additional Health & Safety for 12" Bandsaws

SAFETY IS A COMBINATION OF OPERATOR COMMON SENSE AND ALERTNESS AT ALL TIMES WHEN THE BANDSAW IS BEING USED.

WARNING: FOR YOUR OWN SAFETY, DO NOT ATTEMPT TO OPERATE YOUR BANDSAW UNTIL IT IS COMPLETELY ASSEMBLED AND INSTALLED ACCORDING TO THE INSTRUCTIONS.

SAFE OPERATION

1. The bandsaw should be bolted to a workbench or suitable stand where possible.
2. If you are not thoroughly familiar with the operation of bandsaws, obtain advice from your supervisor, instructor, or other qualified person or contact your retailer for information on training courses. Do not use this machine until adequate training has been undertaken.
3. Never turn the machine 'ON' before clearing the table of all objects (tools, scrap pieces etc.)
4. Ensure that:
 - (i) the voltage of the machine corresponds to the mains voltage.
 - (ii) To use an earthed power source (wall socket).
 - (iii) The cord and plug are in good condition, i.e. not frayed or damaged.
 - (iv) No saw teeth are missing and the blade is not cracked or split. Otherwise replace blade.
 - (v) The blade is properly tensioned and aligned.
5. Never start the machine with the saw blade pressed against the workpiece.
6. Never apply sideways pressure on the blade as this may cause the blade to break.
7. Care must be taken when cutting wood with knots, nails or cracks in it and / or dirt on it, as these can cause the blade to get stuck.
8. Never leave the machine running unattended.
9. Ensure the teeth of the blade are pointing downwards.
10. Do not use saw blades which are damaged or deformed.
11. Replace the table insert when it is worn.
12. When cutting cylindrical timber use a suitable jig to prevent twisting of the workpiece. **See section 12 page 28.**
13. DO NOT operate the machine when the door or the blade guard is not closed.
14. Adjust the guard as close as possible to the workpiece being cut.
15. Ensure the selection of the saw blade and speed are suitable for the material to be cut. For most wood cutting applications the fastest of the two speeds should be used.
See section 12.
16. If the mains lead is damaged, it must only be replaced by a qualified electrician.
17. Never use a long extension cable.
18. WARNING LABELS – It is important that labels bearing Health & Safety Warnings are not removed or painted over. New labels are available from Customer Services.
19. MECHANICAL SAFETY – The security of all clamps and work holding devices should be checked before switching on.
20. WOOD DUST – The fine particles of dust produced in cutting operations are a potential health risk. Some imported hardwoods do give off highly irritant dust which causes a burning sensation. We strongly recommend the use of a dust collector and dust mask/visor (see section 13). Our Customer Services Department will also be happy to advise you on the correct unit for your needs.
21. This machine falls under the scope of the 'Health & Safety at Work etc. Act 1974', and the 'Provision & Use of Work Equipment Regulations 1998'. We recommend that you study and follow these regulations. Further guidance can be found in the Safe Use of Narrow Bandsaws and the Safe Use of Woodworking Machinery code of practice booklet (L114) published by Health & Safety Executive and available by visiting <http://www.hse.gov.uk/pubns/wis31.htm>.

For further help on any of the above matters please contact our Customer Services Department at :-
Tel: 01246 561 520 Fax: 01246 561 537

WARNING: Do not allow familiarity (gained from frequent use of your machine) to cause complacency. Always remember that a careless fraction of a second is sufficient to inflict severe injury.

3. Record Power Guarantee

1. Introduction

1.1 We supply machinery through a network of dealers and authorised distributors and you should be aware that your contract of sale is with the retailer from whom you purchased this product.

1.2 If you are not satisfied with this product you should in the first instance approach the retailer from whom you purchased it.

1.3 Customers have statutory rights to protect them and information on this can be found at the Citizens Advice Bureau or on such web-sites as that operated by the DTI (<http://www.dti.gov.uk>)

1.4 Returning your guarantee card will speed up the claims procedure and can be very helpful as a proof of purchase should the initial receipt be mislaid or damaged. We recommend that this is returned as close to your original purchase date as possible.

1.5 Correct installation, set-up, adjustment and routine maintenance of the machine are the responsibility of the end-user and problems arising from incorrect set-up, adjustment or maintenance are not covered by the terms of this guarantee. However support is available in the first instance from the retailer who supplied you and free technical support is available from Record Power on 01246 561 520 during office hours and from an extensive knowledge base on our website www.recordpower.co.uk. We also recommend that those users who have not had suitable training in the safe use of machinery should seek such training locally before using or attempting to set up and adjust any machinery (please contact your retailer for recommendations in your local area).

2. Guarantee

2.1 In addition to the above Record Power guarantees that for a period of 5 years from the date of purchase the components of this product will be free from defects caused by faulty construction or manufacture.

2.2 During this period Record Power will repair or replace free of charge any parts which are proved to be faulty in accordance with paragraph 2.1 above provided that:

2.2.1 You follow the claims procedure set out below;

2.2.2 We are given a reasonable opportunity after receiving notice of the claim to examine the product.

2.2.3 If asked to do so by us, you return the product to Record Power's premises or other approved premises such as those of the supplying dealer, for the examination to take place.

2.2.4 The fault in question is not caused by continuous industrial use, accidental damage, fair wear and tear, wilful damage, negligence on your part, incorrect electrical connection, unapproved modification, abnormal working conditions, failure to follow our instructions, misuse, or alteration or repair of the product without our approval.

2.2.5 This product has been purchased by you and not used for hire purposes;

2.2.6 This Guarantee extends to the cost of carriage incurred by you returning the product to Record Power as long as it is demonstrated that the defect falls within the terms of this Guarantee and you follow the claims procedure as outlined.

3. Claims Procedure

3.1 In the first instance please contact the retailer who supplied the product to you. In our experience many initial problems with machines that are thought to be due to faulty parts are actually solved by correct setting up or adjustment of the machines. A good dealer should be able to resolve the majority of these issues much more quickly than processing a claim under the guarantee.

3.2 If the dealer who supplied the product to you has been unable to satisfy your query, any claim made under this Guarantee should be made directly to Record Power at the address set out at the foot of this Guarantee. The claim itself should be made in a letter setting out the date and place of purchase, and giving a brief explanation of the problem which has led to the claim. This letter should then be sent with proof of the purchase date (preferably a receipt) to Record Power. If you include a phone number or email address this will help to speed up your claim.

3.3 Please note that it is essential that the letter of claim reaches the address below on the last day of this Guarantee at the latest. Late claims will not be considered.

3.4 We will contact you once we have received your initial written claim. If it is necessary to return the item, in most cases but subject always to clause 2.2.5, we will arrange for collection or will provide freepost information to enable return depending on the weight and size of the product concerned. If the product is to be returned to us, we will agree with you in advance a Returns Number, to speed tracking of the claim and ensure the most appropriate method of return to you is used.

4. Notice

This Guarantee applies to all goods purchased from an authorised retailer of Record Power within the United Kingdom of Great Britain and Northern Ireland. This Guarantee does not confer any rights other than those expressly set out above and does not cover any claims for consequential loss or damage. This Guarantee is offered as an extra benefit and does not affect your statutory rights as a consumer. Additional written copies of this Guarantee can be obtained by writing to the address below. Please include a stamped and self addressed envelope for each copy of the guarantee requested.

Record Power Ltd.

Unit B, Adelphi Way
Ireland Industrial Estate
Staveley, Chesterfield, Derbyshire
S43 3LS

4. Getting to Know Your Bandsaw

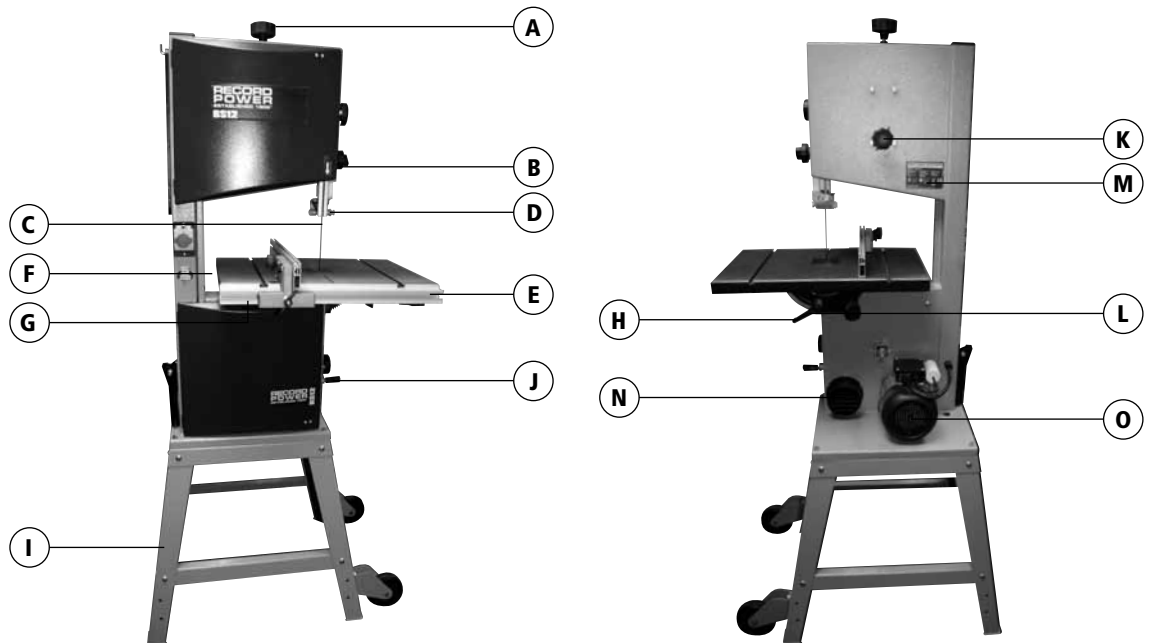

A Blade Tensioning Knob

B Rise & Fall Knob

C Blade

D Upper Blade Guide

E Table

F Rip Fence

G Rip Fence Rail

H Table Tilt Lock Handle

I Stand & Wheel Kit

J Belt Tension & Speed Change Handle

K Blade Tracking Knob

L Table Tilting Knob

M Motor Rating Plate

N 100mm Dust Extraction Port

O Motor

5. Specifications

Blade length: 2240mm

Blade width: 6mm - 15mm

Max depth of cut: 175mm

Throat depth: 305mm

Table size: 480x400mm

Max width blade to rip fence: 185mm

Table height (from floor without stand): 478mm

Table height (from floor with stand): 1086mm

Extraction port: 100mm

Motor power (output): 750W

Weight: 75kg

Footprint (with stand): 791 x 874mm

Table size: 548 x 400mm

Dimensions (with stand): H1680 x W791 x D874mm

6. Stand & Wheelkit Assembly

Stand & Wheel Kit Assembly

CAUTION! The machine is heavy. Additional help or a suitable lifting device or support will be required for lifting the machine onto the stand.

The stand and wheel kit comes as a self assembly unit.

Stand

- A. Upper Frame
- B. Long mid brace supports x2
- C. Short mid brace supports x2
- D. Legs x4
Stand fixing nuts bolts and washers (each) x22

WheelKit

- E. Hex bolt x8
- F. Fixed wheels x2
- G. Tubular handle
- H. Bolts and washers x2

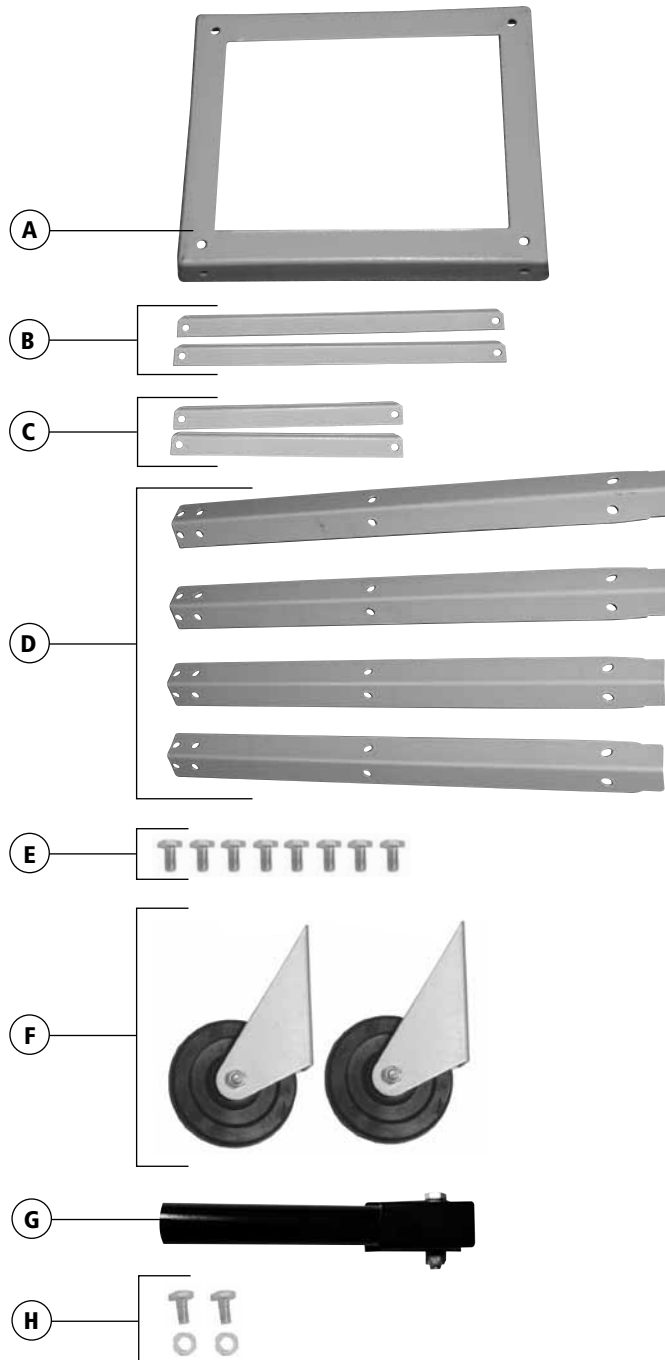

6. Stand & Wheelkit Assembly - Cont.

Note:

When assembling this legstand **Do Not** fully tighten the nuts and bolts until the assembly is complete. Finger tight should be sufficient.

Stand Assembly

1. Locate the four legs (E) and secure them to the upper frame (A) using the nuts, bolts and washers supplied.

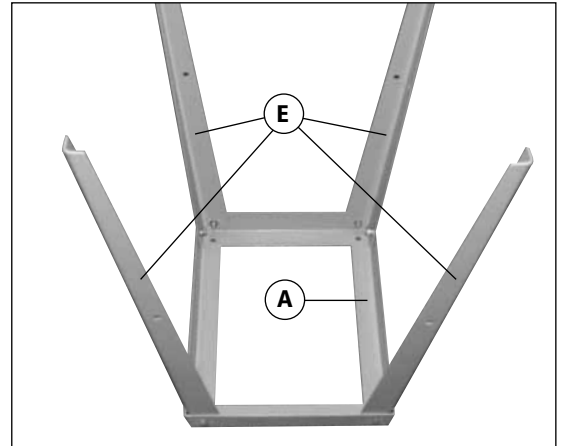

2. Locating holes a third of the way down each leg are for securing the long mid brace supports (C). Fix the long mid brace supports to the frame using the nuts, bolts and washers.

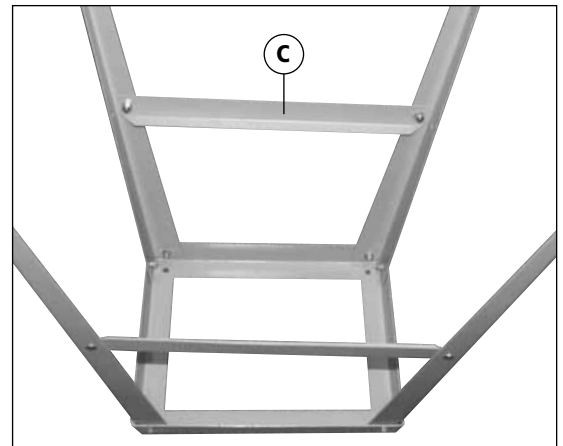

3. Finally, fit the two short mid brace support (D) to the shorter sides of the stand and position the frame upright. Once the frame is upright, the whole assembly should fall into place. All fixings should now be fully tightened.

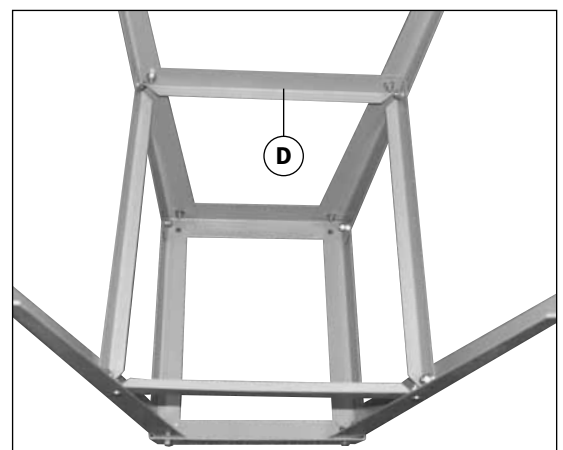

6. Stand & Wheelkit Assembly - Cont.

Wheelkit Assembly

Attach the fixed wheels (G) to the front legs (E) of the stand using the M6x16 hex bolts, Washers, and M6 Nyloc nuts provided.

Note:

For your safety only use the handle to pull the machine. It is unsafe to push the machine using the handle.

When lifting the stand ensure the front legs are not raised higher than 200mm from the ground (or at an angle of more than 17°).

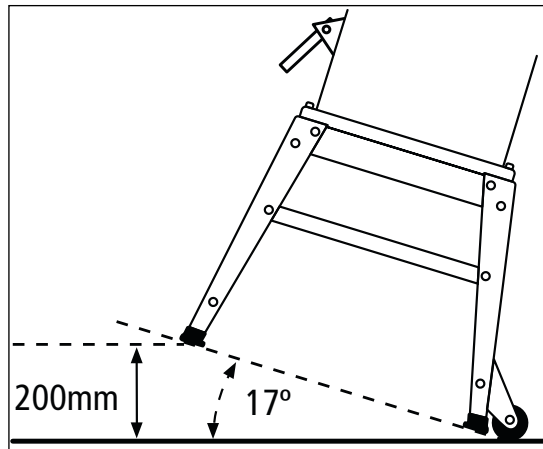
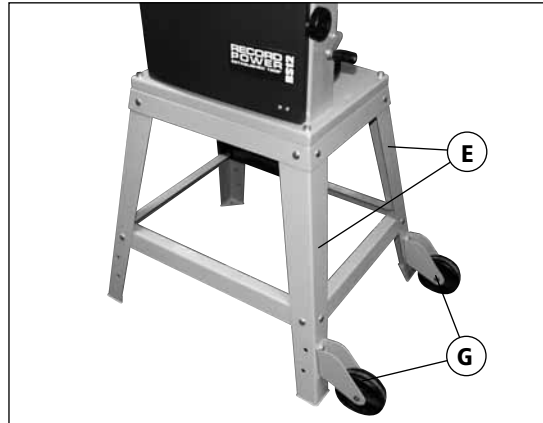

6. Stand & Wheelkit Assembly - Cont.

Fitting the Bandsaw to the Stand

CAUTION!

The machine is heavy. Additional help or a suitable lifting device or support will be required for lifting the machine onto the stand.

1. Lift the bandsaw over the stand, and place the long fixing bolts through the four location holes in the bandsaw base.

Note

When fitting the bandsaw to the stand, ensure that the wheels are positioned at the front of the bandsaw, i.e. below the table of the bandsaw.

2. Secure the bandsaw to the stand with the remaining washers and nuts.



Fitting the Wheelkit Handle to the Bandsaw

Secure the wheelkit handle in position on the rear of the bandsaw column by using the two hex nuts and washers.



7. Machine Assembly

Unpacking and Components Included

The machine is supplied partly assembled. Prior to use, further assembly is required.

When unpacking the machine the following components are included for the initial assembly

A. M6 Nuts x2 and small crank handle

Table Assembly

B. Table

C. Table fixing bolts and washers x4 (each)

D. Table levelling nut and bolt

E. Wing nuts x4

F. Rip fence carrier with scale

G. Rip fence

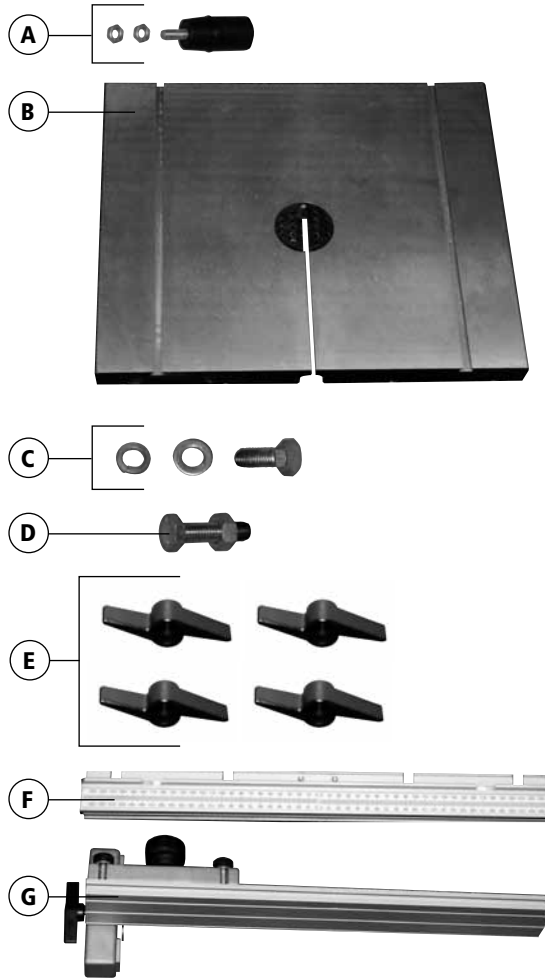

7. Machine Assembly - Cont.

Belt Tension Handle

Attach small crank handle (Fig. 7.1, A) to belt tension and speed mechanism with 10mm spanner (not supplied).

First assemble the crank:

- This is done by fitting one M6 nut to the end of the crank screw.
- Now Insert the end of the crank screw into the corresponding hole in the tensioner.
- Fit the second M6 nut to the crank screw and fully tighten.
- The nuts should be adjusted to allow the small crank handle to rotate freely.

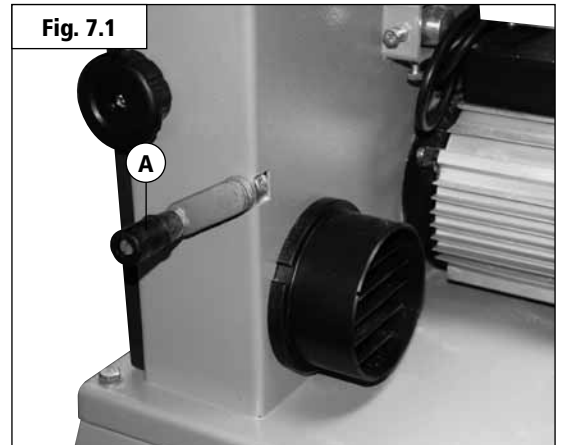

Fitting the Table

Tools Required: - 13mm spanner (not supplied)

With the help of another person, lift the working table onto the trunnion. Mount the working table on the trunnion using the supplied 4 x table fixing bolts and 4 x washers (Fig. 7.2, A).

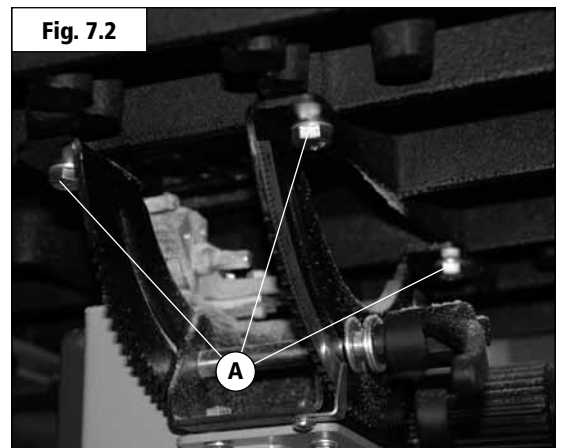

Fitting the Fence Rail

Take the four wing nuts (Fig. 7.3, A) and washers and fit them into the threaded holes on the underside of the table but do not fully tighten.

Slide the fence rail into the gap left between the table and the star knobs then tighten the star knobs to secure the fence rail.

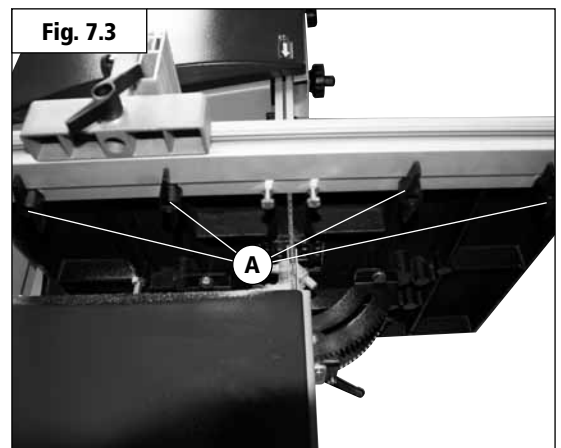

7. Machine Assembly - Cont.

Fitting the Rip Fence

Slide the rip fence assembly onto the fence rail.

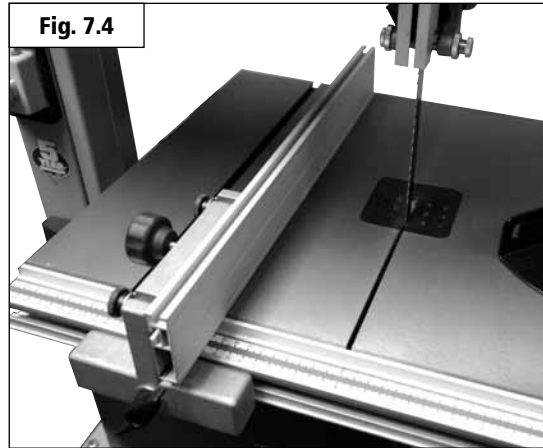

Fence Alignment 1

Adjustment can be made to the fence (Fig. 7.5, A) in relation to being square to the blade. This is done by slackening the four wing nuts on the fence rail (Fig. 7.5, B) and adjusting the rails position until the fence is square to the blade.

Note:

This adjustment must be made with the fence in a clamped position

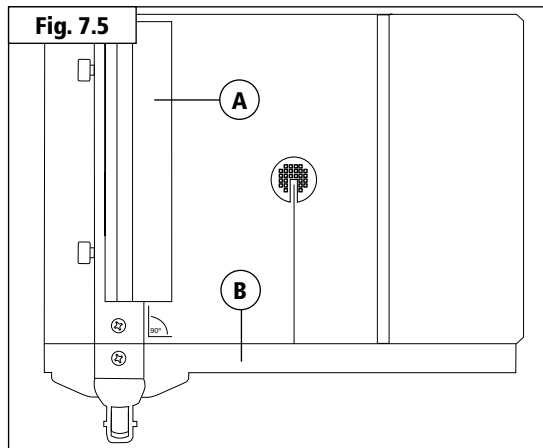

Fence Alignment 2

Check that the fence (Fig. 7.6, A) is 90° to the table (Fig. 7.6, B) using a suitable square, there is no need for adjustment as this area is factory set. However if settings have slipped during transit slight adjustment may be needed. The best way to adjust this is by adding extra washers or shims between the fence rail (Fig. 7.6, D) and the underside of the table where required.

Tip:

When an accurate cut is crucial it is good practice to check all settings before machining the workpiece and make a test cut with some scrap material.

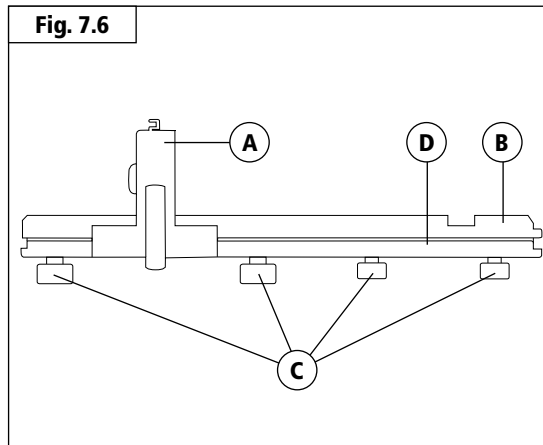

8. Setting Table Square to Sawblade

Setting the Table Stop at 90° to the Sawblade

CAUTION! Before carrying out any adjustments or maintenance ensure that the machine is isolated and disconnected from the electricity supply.

Tools Required:- Small 90° square (Not supplied)

The table can be set at 90° to the Bandsaw Blade (Fig. 8.1) by adjusting the table stop screw (Fig. 8.2) underneath the table.

1. First offer the square up to the blade to give an indication of adjustment required. (Fig. 8.1)
2. If the table is not at 90° to the blade use table tilting mechanism (Fig. 8.3) to adjust the table until it is 90° to the blade. If the table stop screw (Fig. 8.2, A) position is too high it may be necessary to wind this down out of the way so 90° can be achieved.
3. Once the table is at 90° to the blade lock off the lock handle on the table tilt mechanism to secure the table position (Fig. 8.3).
4. Now set the table stop screw (Fig. 8.2, A), the table stop screw should be adjusted to meet the flat registration point (Fig. 8.2, B) on the underside of the table (now set at 90°) to ensure that the table always returns to square after tilting. The table stop screw is located above the bandwheel on the lower bandwheel housing. By first slackening the locking nut and then adjusting the hex screw the table stop screw can be set correctly. Re-tighten the locking nut making sure that the setting is maintained.

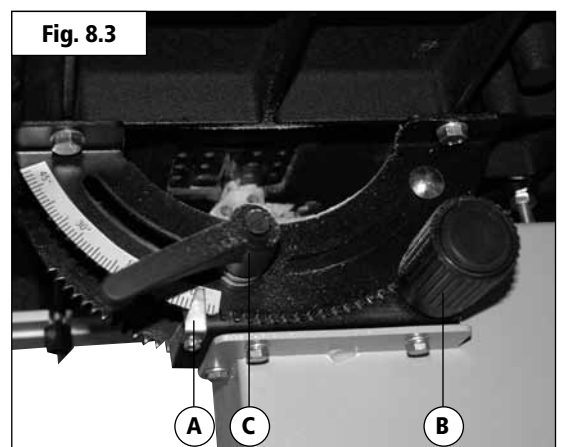
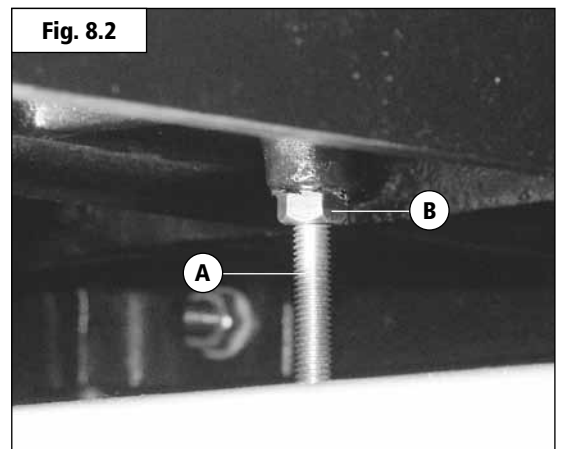
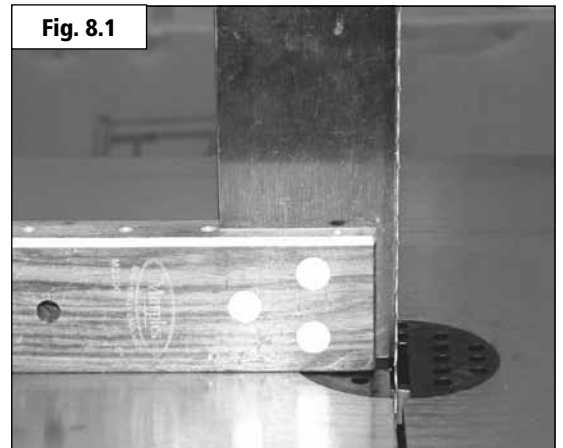

Adjusting the Table Tilt Scale

Once the table is set at 90° to the Bandsaw Blade it may be necessary to adjust the angle pointer on the angle scale so any further angles are accurate. To do this use a Phillips screwdriver to loosen the pan head screw and adjust the pointer to 0° (Fig. 8.3, A).

Tilting the Table

The tilt mechanism will be used when squaring the table to the blade. Tilt the table as follows: Loosen the lock handle (Fig. 8.3, B) on the table trunnion. Turn the table tilting knob (Fig. 8.3, C) to adjust the table angle. Use the angle indicator scale on the trunnion bracket to find the desired angle. Re-tighten the lock handle to secure the table.

9. Bandsaw Blade Set Up

Tensioning the Blade

CAUTION! Before carrying out any adjustments or maintenance ensure that the machine is isolated and disconnected from the electricity supply.

The blade tensioning knob (Fig. 9.1, A) should be used to increase or decrease tension.

The only accurate way to check a blade is with a tension meter, these are very expensive so most users may need another method. We suggest testing the tension by the amount the blade will deflect sideways. First set the guides to 6" above the table, ensuring the saw is turned off push the blade sideways with a reasonable amount of pressure using the index finger. When pushing with the index finger a correctly tensioned blade should not move more than a 1/4" sideways (See Fig. 9.2)

However perhaps the most tried & tested way of blade tensioning is simply: if the bandsaw is cutting accurately then the blade is tensioned correctly, if the blade tends to wander & an accurate cut cannot be achieved then the blade tension needs adjusting.

If the machine is to stand idle for a period it is good practice to slacken tension & re-tension when next using.

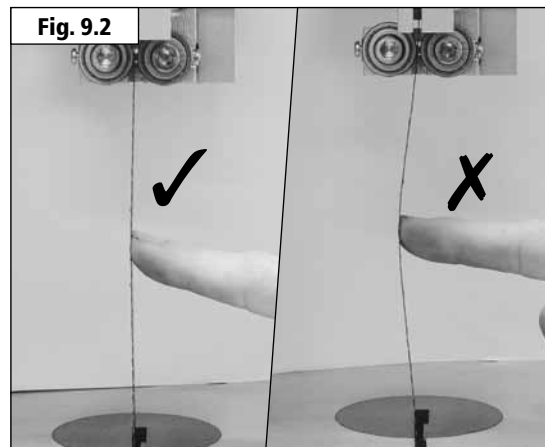
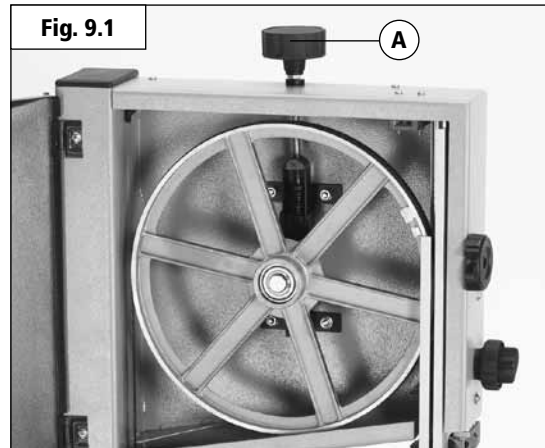

9. Bandsaw Blade Set Up - Cont.

Tracking the Bandsaw Blade

Isolate the machine from the supply by unplugging the mains plug. Set the tracking of the blade before setting the blade guides.

Once the blade is tensioned, track the blade by turning the upper bandwheel by hand and adjusting the tracking knob (Fig. 9.3, A). By turning the tracking knob clockwise the blade will move towards the back of the bandwheel, by turning the tracking knob anti-clockwise the blade will move to the front of the bandwheel. The blade should run as close to the centre of the bandwheel as possible (Fig. 9.4). On narrow blades (e.g 1/4" and 3/8") it may be necessary to run the blade to rear of the bandwheel. After the blade is tracked in the desired position on the bandwheel, rotate the wheel several more times by hand without any further adjustment ensuring that the blade remains in the same position. Once this has been achieved lock the tracking knob with the winged nut (Fig. 9.3, B).

Note:

It takes a few revolutions of the bandwheel for the effecting adjustment on the tracking knob to become apparent. To avoid over-adjusting, make small gradual adjustments on the tracking knob and revolve the bandwheel on a few times to check the alignment of the blade before making further adjustments.

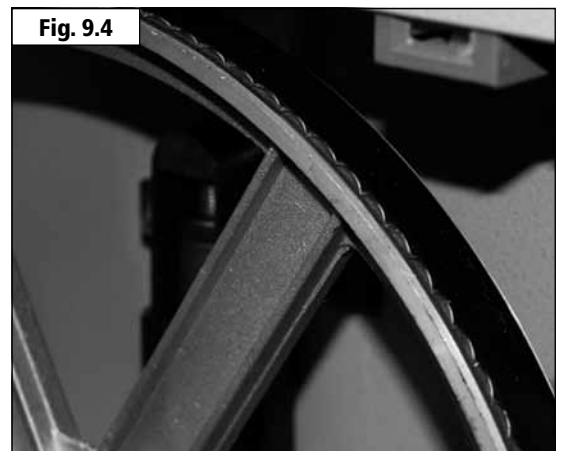
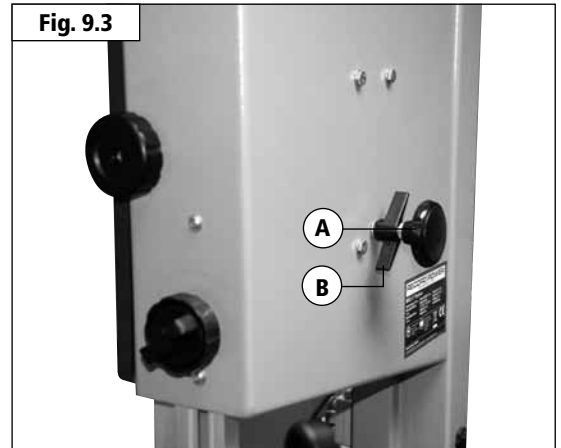

9. Bandsaw Blade Set Up - Cont.

Adjusting the Upper Guides

CAUTION! Before carrying out any adjustments or maintenance ensure that the machine is isolated and disconnected from the electricity supply.

First check that all the roller guides are moving freely. To adjust the upper blade guides, first position the guide assembly relative to the blade by slackening off the grub screws (Fig. 9.5, A) and moving the guide carrier (Fig. 9.5, B) until the roller guides (Fig. 9.6, C) are just behind the gullets (Fig. 9.6, B) of the blade.

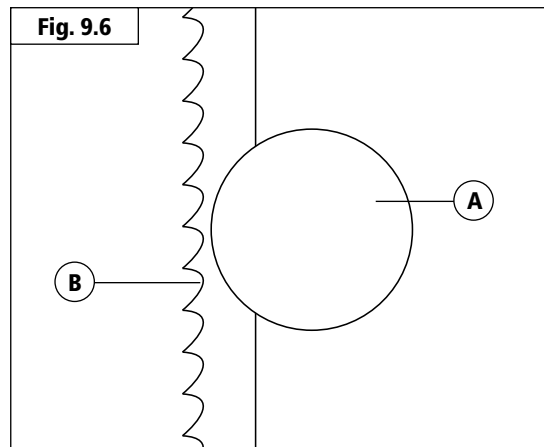
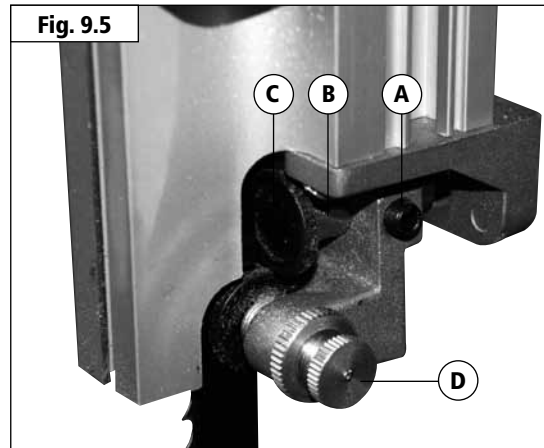

Next set the roller guides (Fig. 9.7, A) as near as possible to the blade (Fig. 9.7, B) without actually touching. This is done by unlocking the nut on each side of the guide adjustment (Fig. 9.5, D). Do not let the roller guides actually touch the blade as this will adversely affect the life of the blade.

Finally adjust the blade support roller (Fig. 9.7, A) to be just clear of the back of the blade (Fig. 9.7, B). Do this by unlocking the grub screw (Fig. 9.5, D).

When the correct adjustment is reached lock the blade support roller in position.

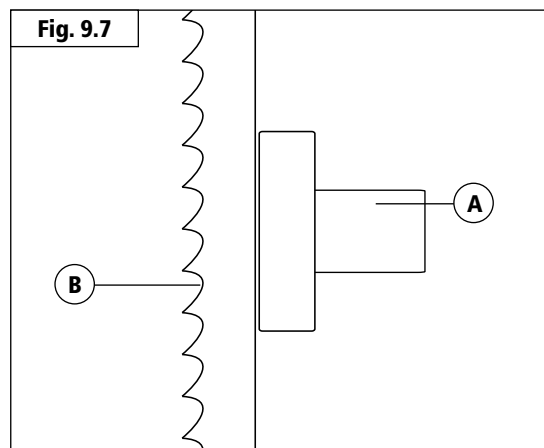

9. Bandsaw Blade Set Up - Cont.

Adjusting Lower Guides

Note:

Adjustment of the lower guides can be made by removing the table insert and working from above as well as below the table

1. To adjust the lower blade guides, first slacken off the nut (Fig. 9.8, A), move the guide carrier casting so the guides are just behind the gullets of the blade.
2. Next set the side guides (Fig. 9.8, B) as near as possible to the blade without actually touching. This is done by releasing the grub screw (Fig. 9.8, D).
3. Finally adjust the thrust bearing (Fig. 9.8, E) to be just clear of the back of the blade by slackening off the locking knob (Fig. 9.8, F) & moving the thrust bearing.

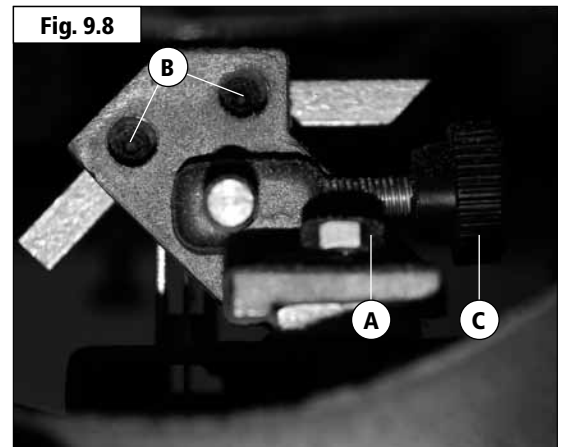

Adjusting the Cutting Height

Once the blade is set, the cutting height must be adjusted so there is maximum guarding for the blade. Also so the blade guides are providing optimum support to the blade.

To adjust the cutting height loosen the rise & fall lock knob (Fig. 9.9, A) and turn the outer ring (Fig. 9.9, B) to raise or lower the guide post/upper blade guide assembly to the desired height.

Note:

The upper blade guide should provide approximately 5mm clearance above the work piece.

After the desired position has been set tighten the rise & fall lock knob.



10. Drive Belt Adjustment & Speed Change

Adjusting the Drive Belt Tension

CAUTION! Before carrying out any adjustments or maintenance ensure that the machine is isolated and disconnected from the electricity supply.

Use the belt tensioning handle (Fig. 10.1, A) to adjust the tension of the drive belt. Rotate the handle anti-clockwise to increase the tension and clockwise to decrease tension. As a guide the belt is adequately tensioned when using the index finger to impart reasonable pressure on the belt - the belt should not deflect more than 1/4". But like tensioning a bandsaw blade this is very subjective and the best test is in operation, if the belt isn't slipping or wearing excessively and there is adequate power being applied to the bandwheels then the drive belt is tensioned correctly.

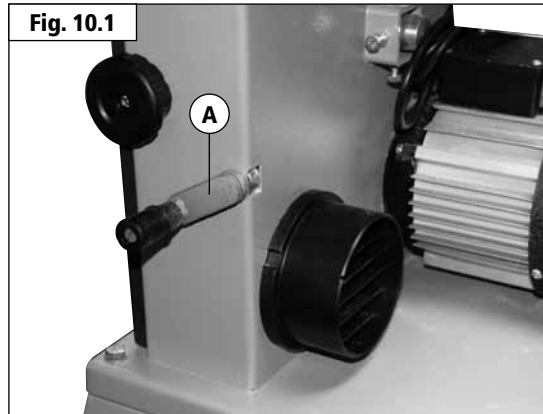

Changing the Blade Speed

The BS12 has two blade speeds 820 m/min for wood and 380 m/min for some plastics and acrylics. This machine is not suitable for cutting metals.

The lower bandwheel has two, integral, multi vee form pulleys and the motor shaft has a twin multi vee form pulley.

The vee belt (Fig. 10.2, A) passes around the bandwheel pulley, the motor pulley (Fig. 10.2, B) and the plain tension roller (Fig. 10.2, C). The belt tension is released and applied by using the crank handle, this moves the tension roller and allows the speed to be changed.

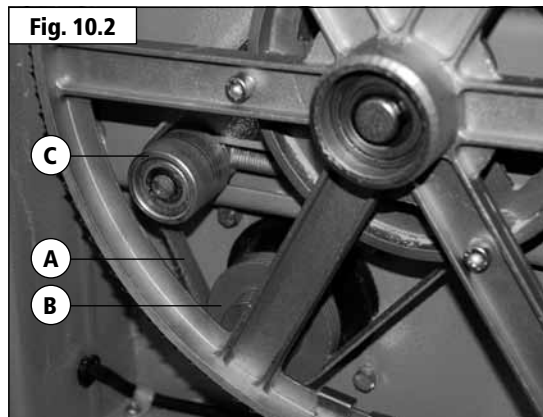

High Speed 802 m/min

For high speed the belt should be fitted to the rear pulley on both the motor and bandwheel.

Lower Speed 372 m/min

For low speed the belt should be fitted to the front pulley on both the motor and bandwheel.

11. Connection of the Electricity Supply

Once the machine has been correctly assembled and set up the electricity supply can be connected.

The machine can only be connected to a single phase supply. Before connecting the electrical supply ensure that it is the correct voltage, phase and frequency, and that it has sufficient capacity for the machine. The relevant information can be found on the rating plate located on the rear of the machine.

Machines supplied for use in the UK are fitted with a BS1363 plug fitted with a 13 amp fuse. Ensure that you use the appropriate plug for use in other countries. If the plug fitted to the machine is changed for any reason, the wires in the mains lead are coloured in accordance with the following code:

Green and Yellow:	Earth
Blue:	Neutral
Brown:	Live

As the colours of the wires in the mains lead may not correspond with the coloured markings identifying the terminals on your plug, proceed as follows:

The wire coloured green and yellow must be connected to the terminal marked 'E' or by the earth symbol ~ or coloured green; or green and yellow.

The wire coloured blue must be connected to the terminal marked 'N' coloured black.

The wire coloured brown must be connected to the terminal marked 'L' or coloured red.

Note:

It is important that the machine is effectively earthed.

If in doubt about the connection of the electrical supply consult a qualified electrician.

RCD (Residual Current Device)

For your additional safety we always recommend the use of an RCD (sometimes called Residual Current Circuit Breaker or Earth Leakage Circuit Breaker).

The machine must not be connected to a TN-S power supply system. A circuit breaker (13A) with RCD module (30A) must be installed for supplying electric power to this machine, in order to protect the user against electrical shock due to indirect shock.

Connect the main leads to a standard 230V±10% (50Hz+1%Hz) electrical supply which has devices for protection against under-voltage, over-voltage, over-current as well as a residual current device (RCD) with maximum residual current rated at 0.03A, the main connection must have maximum 13A time-lag fuse.

11. Connection of the Electricity Supply - Cont.

Switch the machine on by pressing the green button in the switch unit.

Switch the machine off by pressing either the outer red button or inner red button on the switch unit.

Note:

Depending on the condition of the electrical mains supply, slight voltage reductions may occur when the machine is switched on (eg momentary dimming of a light bulb). If the mains impedance Z_{max} is <0.459 Ohms such reductions should not occur. Please contact your local authority if you require further information.

Replacing the Power Supply Cable

Replacement of the power supply cable should only be done by a qualified electrician.

WARNING! To avoid electrocution or fire, any maintenance or repair to electrical system should be done only by qualified electricians using genuine replacement parts.

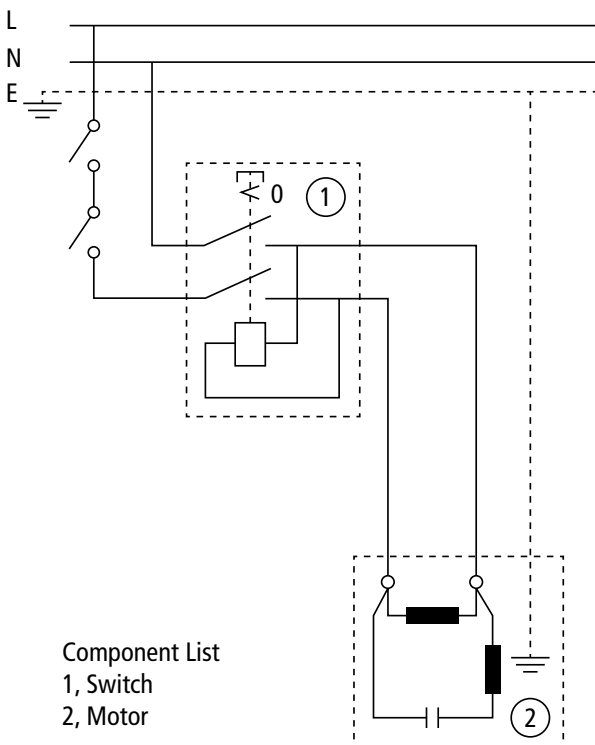

12. Operation & Bandsawing Practice

Basic Bandsawing Principles

- The blade cuts on a continuous down stroke.
- Slowly feed the workpiece towards the blade, using only light pressure whilst letting the blade do the cutting.
- Firmly hold the workpiece and feed it towards the blade slowly, using the push stick and keeping your hands well away from the blade.
- For best results the blade must be sharp. Damaged or worn blades should always be replaced.
- Select the right blade for the job, depending on the thickness of the wood and the cut to be made (Fig. 12.1).
- For straight cutting use the rip fence supplied.
- When cutting shapes, follow the design marked out by pushing and turning the workpiece evenly. Do not attempt to turn the workpiece without pushing it, as this may cause the workpiece to get stuck, or the blade to bend.

CAUTION! Particular care should be taken towards the end of the cut as there will be a sudden decrease in resistance and care must be taken to stop hands from being thrown into the blade.

Always ensure that your machine is properly maintained and clean. Before commencing work on an important project, it is advisable to familiarise yourself with the operation of the equipment by practising on low value materials.

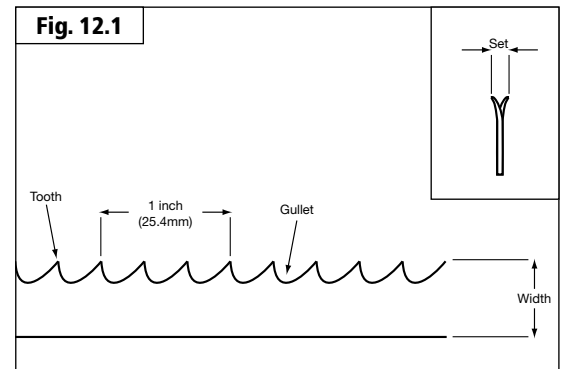

12. Operation & Bandsawing Practice - Cont.

Complicated Cutting

Very complicated cuts and small radius curves are the best accomplished with the aid of pre-drilled holes combined with a few tangential or radial cuts. This technique will achieve excellent results without putting undue tension on the blade and blade guide assembly.

Reversing the Blade Out of a Cut

If at all possible we advise that reversing out of a cut is avoided. But in situations such as cutting scrolls it may not be possible to complete a cut. This requires the blade to be reversed out of the cut. Care is necessary to minimise damage to the work and blade. When removing large pieces of material it is advisable to make the shorter cut last to avoid having to reverse out of the longer cut. When reversing out of a cut it is advisable to leave the blade running, but take extreme care not to pull the blade off the band wheel.

WARNING! In circumstances such as cutting deep or wet timber, the work piece may close up behind the blade causing it to stall. In the event that the blade stalls whilst cutting, ease the work piece backwards slightly, to release feed pressure from the blade. Allow the blade to reach full speed before continuing to feed the work piece in to the blade. If the blade fails to move when feed pressure is released, immediately switch off the machine and disconnect the power supply before attempting to free the blade from the work piece.

WARNING! If any component of the machine fails whilst in use or if the blade should break whilst the machine is running, immediately switch off the machine and disconnect from the power supply. Remove the faulty component and replace only with genuine Record Power replacement parts. Any electrical components should only be replaced by a suitably qualified person. To replace a broken blade, please refer to the section of this manual entitled "Band saw Blade Set Up". Always remember to fully release the blade tension mechanism before attempting to fit a new blade. If you are in any doubt about using the machine following a failure or if you need to order replacement spare parts or blades, please contact our Technical Department on 01246 561 520.

12. Operation & Bandsawing Practice - Cont.

Blade Selection (TPI)

The selection of the best blade configuration (see the table below) is necessary for optimum cutting performance.

- Correct blade choice is primarily dependant on two factors: material thickness and material type.
- Greater TPI should be selected as material thickness decreases.
- However, if the TPI is too great, the tooth loading will be insufficient to enable penetration; and cutting. The teeth will also rapidly lose their sharpness.
- For thicker material a lower TPI should be used otherwise the gullet will not be sufficient to clear the waste and the blade will stall or burn the wood.

The accompanying blade selection chart (see the table below) gives guidance on the TPI that should give the best results when cutting a variety of material types and thickness. (See the table below) provides recommendations on selecting the correct blade for a variety of commonly used materials. If in doubt about any aspects of blade selection contact Customer Services on 01246 561 520 for assistance.

The table provides a guide to selection only. Exact tooth configurations are not always available, nor are all blade configurations covered, but the principles remain the same.

For special applications, custom blades can be supplied please call Customer Services on 01246 561 520 and we can advise you accordingly on your specific needs.

Material	Material Thickness			
	<6mm	6-12mm	12-25mm	>25mm
Perspex	16 TPI	14 TPI	-	-
Chipboard	-	6 TPI	3-6 TPI	3-4 TPI
Fibre board	16 TPI	14 TPI	-	-
Hardboard	10 TPI	-	-	-
Plywood	10 TPI	8 TPI	6 TPI	3-4 TPI
Strawboard	14 TPI	10 TPI	-	-
Cork	14 TPI	6 TPI	3 TPI	3-4 TPI
Leather	14 TPI	-	-	-
Rubber	10 TPI	8 TPI	-	-
Wood -log	-	-	-	3-4 TPI
Wood -soft	6 TPI	3-6 TPI	3-4 TPI	3-4 TPI
Wood -hard	6 TPI	3-6 TPI	3-4 TPI	3-4 TPI
Wood -wet	-	-	-	3-4 TPI

12. Operation & Bandsawing Practice - Cont.

Blade Selection (TPI) - Cont.

Having selected an appropriate blade for the particular thickness and type of material to be sawn, it is essential that the saw blade is allowed to cut freely by not applying too much pressure.

- The need for excessive pressure is likely to be a result of the incorrect blade selection or a worn blade and will result in inaccurate cutting and possibly blade breakage.

Blade Selection (Width)

- When cutting shapes, the width of the blade limits the minimum radius that can be cut.
- If the blade is too wide for the cutting radius the blade will twist and possibly jam or break.
- The smaller the radius the narrower the blade has to be. The adjacent diagram provides guidance on the minimum radius to be cut with the most commonly used blade widths.

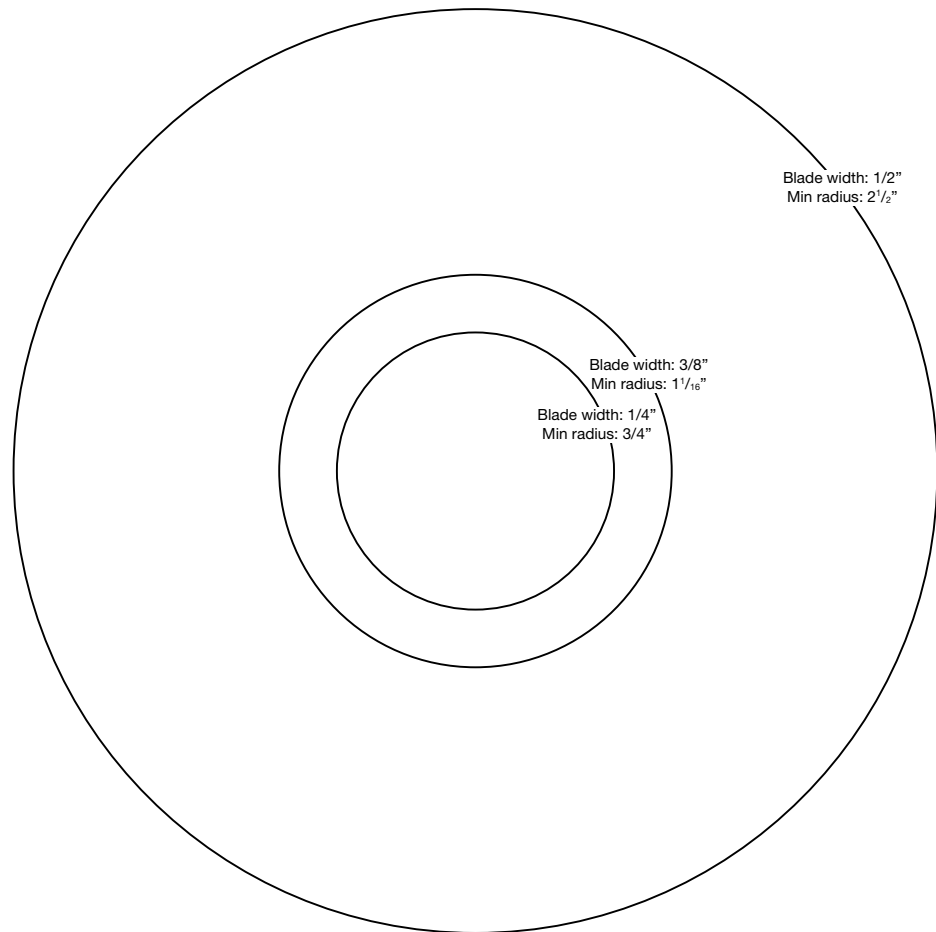

12. Operation & Bandsawing Practice - Cont.

Blade Selection Summary

To see how TPI and width of the blade come together, use the table opposite for reference.

- Regularly examine the blade for excessive damage or cracking as a result of fatigue. If such damage is present replace the blade.
- It is important to use a sharp blade. Dull teeth result in increased feed pressure producing a poor quality finish and an inaccurate cut.

Note:

as well as the blades listed, we can also supply bandsaw blades to almost any specification please call Record Power Customer Services on 01246 561 520 for further details.

		← Narrow Blade		Wide Blade →	
		Application TIGHT CONTOUR	Application MEDIUM CONTOUR	Application STRAIGHT CUT / LARGE CONTOUR	
Coarse Blade ↑ Fine Blade ↓	Material Thick / Soft Timber	Blade Spec width 1/4" teeth 4 TPI	Blade Spec widths 3/8" teeth 4 TPI	Blade Spec widths 1/2" teeth 4 TPI	
	Material General Timber	Blade Spec width 1/4" teeth 4 - 6 TPI	Blade Spec widths 3/8" teeth 4 - 6 TPI	Blade Spec widths 1/2" teeth 4 - 6 TPI	
	Material Thin / Hard Timber	Blade Spec width 1/4" teeth 6 TPI	Blade Spec widths 3/8" teeth 6 TPI	Blade Spec widths 1/2" teeth 6 TPI	

Record Power BS12 Blade Range

Record Power's high performance bandsaw blades are manufactured to the highest quality tolerances using a specialist premium high carbon steel strip.

The extensive quality control program which involves digital tooth profile checks, set analysis, straightness testing, hardness testing and micro structural analysis results in a blade that cuts straighter and has harder, longer lasting teeth. A premium British blade that can last up to ten times longer than other blades on the market.

The following range of blades are available for the BS12. To order any of these blades please contact our Customer Services Department on 01246 561 520 who will advise you of your nearest retailer or alternatively a mail order supplier.

BB881406

1/4" x 6 TPI Bandsaw Blade

BB883806

3/8" x 6 TPI Bandsaw Blade

BB881204

1/2" x 4 TPI Bandsaw Blade

BB881206

1/2" x 6 TPI Bandsaw Blade

BB883403

3/4" x 3 TPI Bandsaw Blade

BB88-3PACK

1/4 x 6 TPI Bandsaw Blade

3/8 x 6 TPI Bandsaw Blade

5/8 x 6 TPI Bandsaw Blade

BB88CUS

Custom width & tooth pattern

12. Operation & Bandsawing Practice - Cont.

Custom Jigs & Work Support

A bandsaw is one of the most versatile machines in the workshop and with careful lateral thinking many problems encountered on a job can be overcome. By making and using custom jigs repetitive and accurate work can easily be achieved, the following illustrations are some examples of typical jigs and supports used on a bandsaw.

Ex. 1. Supporting large workpieces with roller stands or take off tables.

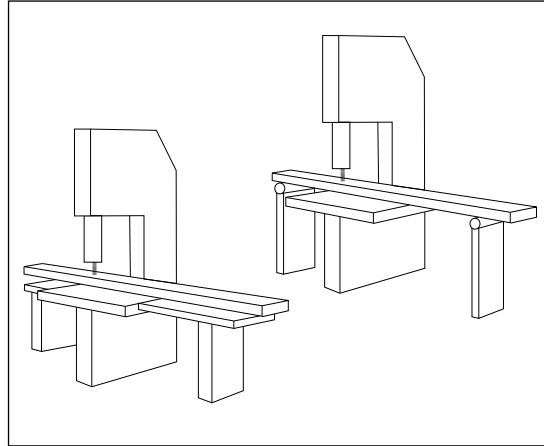

Ex. 2. Always support round pieces with a wedge.

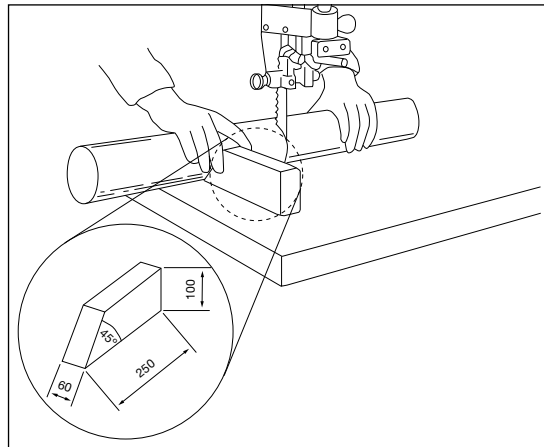

Ex. 3. Use a side pressure pad for accurate cutting of taller material.

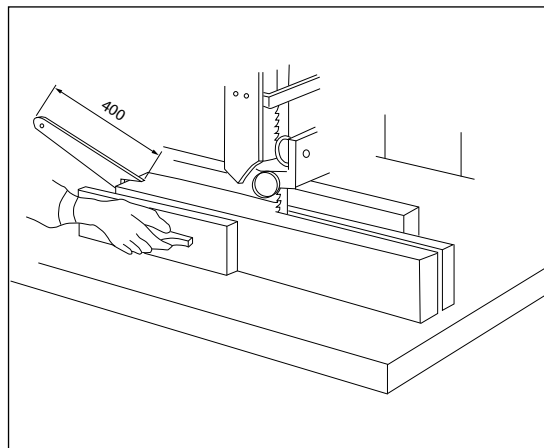

12. Operation & Bandsawing Practice - Cont.

Ex. 4. Chamfered pieces can be cut squarely using an additional support jig on the opposite side of the work piece to the fence.

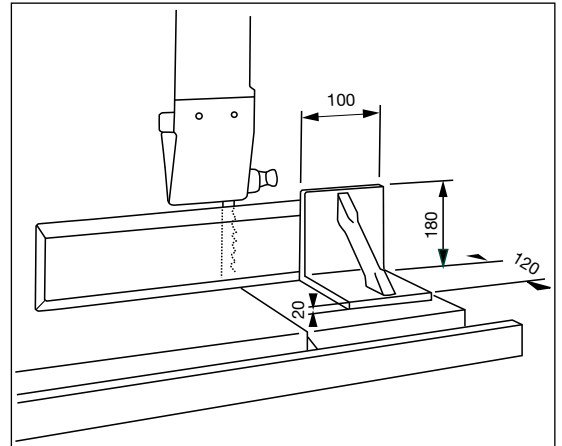

Ex. 5. Jig for accurate repetitive wedges.

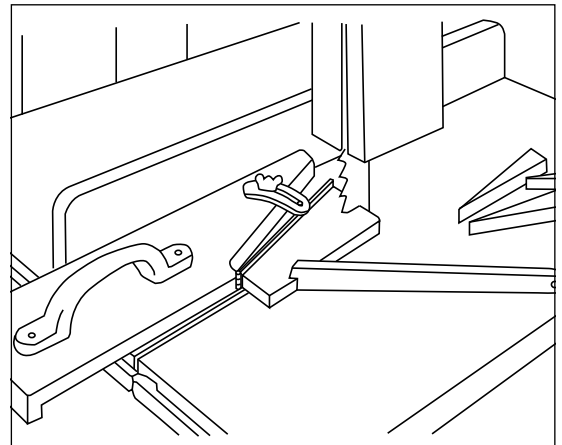

Ex. 6. By mounting a registration pin on a slide repetitive circles can easily be achieved.

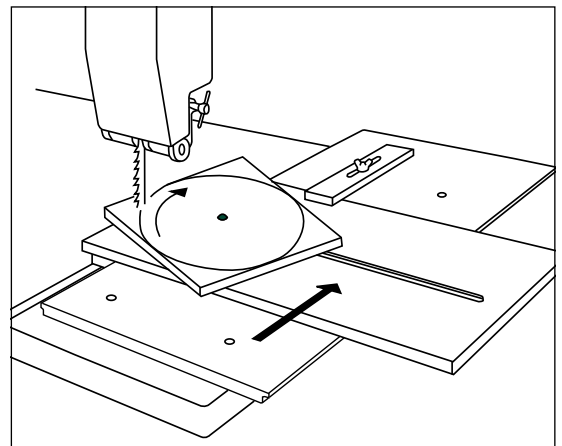

12. Operation & Bandsawing Practice - Cont.

Ex. 7. Angle cutting jig for accurate repetitive compound angles.

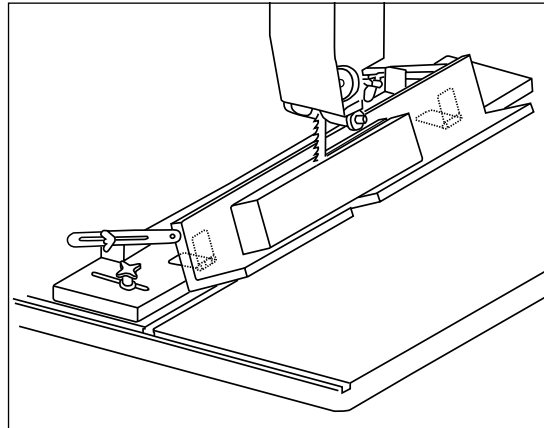

13. Dust Extraction

The Importance Of Dust Extraction

Before the machine is started, ensure that adequate dust extraction provisions have been installed. Dust extraction is extremely important not only for health and safety but also for the correct upkeep of the machine. Saw dust can cause the machine not to operate properly or even fail completely. By keeping the machine free of large amounts of waste the performance will be optimised.

If a large amounts of MDF or toxic woods are to be cut we recommend that there is a good ventilation system in place and that a particle mask is worn as minimum protection.

Record Power Extractors

Record Power offer a range of high quality dust extractors, starting at the single motor 45 litre RSDE1 right up to the 200 litre twin motor DX5000. We offer both drum and bag type extractors high filtration models filter down 0.5 micron providing protection from harmful fine dusts such as MDF. Chip collectors filter down to 5 micron. All Record Power dust extractors & chip collectors have 100mm inlets and hoses.

DX1000 High Filtration Dust Extractor

Drum type extractor, 45 litre capacity, single 1kw motor, suitable for intermittent use i.e must be switched off for 20 minutes every hour.

0.5 micron filtration; suitable for MDF

RSDE1 High Filtration Dust Extractor

Drum type extractor, 45 litre capacity, single 1kw motor, suitable for intermittent use i.e must be switched off for 20 minutes every hour.

0.5 micron filtration; suitable for MDF

RSDE2 High Filtration Dust Extractor

Drum type extractor, 50 litre capacity, single 1kw motor, suitable for intermittent use i.e must be switched off for 20 minutes every hour.

0.5 micron filtration; suitable for MDF

DX4000 High Filtration Dust Extractor

Drum type extractor, 80 litre capacity, Twin 1kw motor, suitable for heavy usage i.e if one motor is switched off for 20 minutes then the other can be used thus enabling continuous usage. Or both motors can be used simultaneously giving maximum suction but in this mode the extractor must be switched off for 20 minutes every hour. **0.5 micron filtration; suitable for MDF**

DX5000 High Filtration Dust Extractor

Bag type extractor, 200 litre capacity, Twin 1kw motor, suitable for heavy usage i.e if one motor is switched off for 20 minutes then the other can be used thus enabling continuous usage. Or both motors can be used simultaneously giving maximum suction but in this mode the extractor must be switched off for 20 minutes every hour. **0.5 micron filtration; suitable for MDF**

CX2600 Chip Collector

Large capacity chip collector, with a powerful 0.37kw induction motor. An extremely smooth running unit suitable for continuous usage. Very quiet impeller system extracts dust and chippings. **5 micron filtration; unsuitable for MDF**

CX3000 Chip Collector

Larger capacity chip collector, with a more powerful 0.75kw induction motor and heavy duty construction. An extremely smooth running unit suitable for continuous usage. Very quiet impeller system extracts dust and chippings.

5 micron filtration; unsuitable for MDF

Air Cleaners

It is strongly advised to also use an air cleaner to remove the fine airborne dust present in the workshop which cannot be removed using machine extraction. Record Power offer a range of air cleaners suitable for all home workshops. Please contact your preferred stockist, call us on 01246 561 520 or visit www.recordpower.co.uk for full details.

13. Dust Extraction - Cont.

	DX1000	RSDE1	RSDE2	DX4000	DX5000	CX2600	CX3000
Bandsaws Circular saws Sanders Intermittent usage	✓ Recommended	✓ Recommended	✓ Recommended	✓ Recommended	✓ Recommended		
Bandsaws Circular saws Sanders Heavy usage				✓ Recommended	✓ Recommended		
Planer Thicknessers Spindle Moulders Universals Intermittent usage	✓ Recommended	✓ Recommended		✓ Can be used	✓ Recommended	✓ Recommended	✓ Recommended
Planer Thicknessers Spindle Moulders Universals Heavy usage				✓ Can be used	✓ Recommended	✓ Recommended	✓ Recommended
Dust Extraction System Intermittent usage				✓ Can be used	✓ Recommended		

14. Maintenance

Replacing the Bandsaw Blade

CAUTION! Before carrying out any adjustments or maintenance ensure that the machine is isolated and disconnected from the electricity supply.

HAZARD! Take great care when unpacking the bandsaw blade as they are usually folded and can spring out very suddenly with great force.

Tip:

If the new blade being fitted is a different width to the one being removed, it is advisable to move back and slacken off all blade guides before fitting the new blade as this will make fitting easier. Whenever a different size blade is fitted the blade guides will always need re-setting.

1. Remove the rip fence and fence rail by unscrewing the wing nuts (Fig. 14.1, A) located on the underside of the table.
1. Open the top and bottom bandwheel doors.
2. Turn the blade tension knob to release the blade tension (Fig. 14.2, A).
3. Remove the bandsaw blade by feeding it through the slot in the table, upper blade guides & guard and slot in the spine of the machine taking care not to cut yourself, wear gloves if necessary.
4. If the new blade being fitted is a different width to the one being removed, before the new blade is placed around the bandwheels:
 - Adjust the tension wheel to suit the new blade size.
 - Place the new blade on the bandwheels.
 - Fit the new blade ensuring the blade teeth are pointing downwards and towards you at the position where the blade passes through the table.
 - Ensure the blade is fully in place on bandwheel, re-apply tension using the tensioning knob.
 - Fine adjust the blade tension further if required using the blade tension wheel.

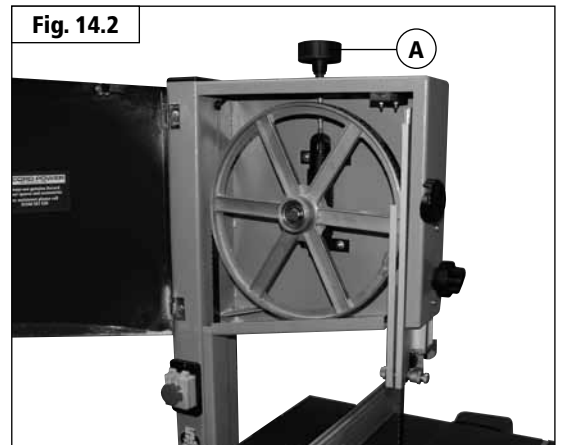
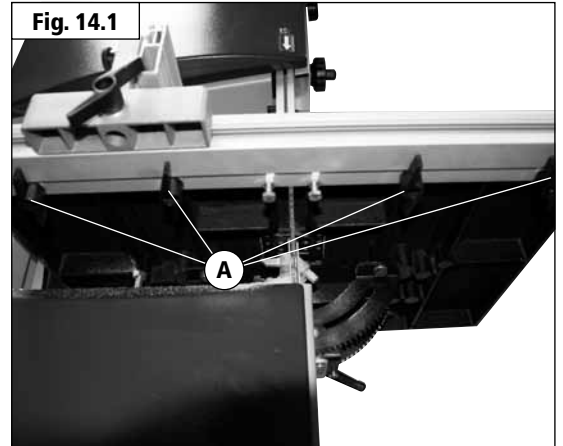

14. Maintenance - Cont.

5. If the new blade width is the same as the blade being removed:
 - Fit the new blade ensuring the blade teeth are pointing downwards and towards you at the position where the blade passes through the table.
 - Ensuring that the blade is fully in place on bandwheel. Simply re-apply tension using the tensioning knob.
 - Fine adjust the blade tension further if required using the blade tensioning knob.
 6. Check the blade tracking on the newly fitted blade by turning the upper wheel by hand. The blade should run as close to the centre of the bandwheel as possible. On 1/4", 3/8" and 1/2" blades it may be necessary to run the blade to rear of the bandwheel (see section 6.2.)
 7. If required adjust the tracking using tracking knob (15) and lock knob to the rear of the upper bandwheel housing. When the tracking is correct lock the setting (see section 6.2).
 8. Re-set the blade guides (see sections 6.3 & 6.4)
 9. Close and lock both the bandwheel doors before re connecting the power supply.
- For further information on blade tensioning see section 6.1.

Replacing the Drive Belt

To replace the drive belt (Fig. 14.4, A) simply loosen the tension on the belt using the tension handwheel. Remove the lower bandwheel (Fig. 14.4, B) by undoing the circlip (Fig. 14.4, C) on the hub. Remove the old belt and fit the new one. Once the drive belt is in place re-fit the lower bandwheel and tighten the nut. Now tension the drive belt using the tension handwheel. For further information on tensioning the drive belt please.

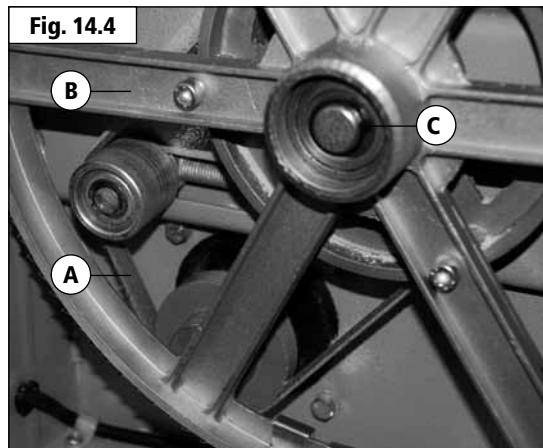

14. Maintenance - Cont.

The Blade Guide System

In general usage it is advisable to carefully apply silicon spray to the blade guides to ensure free movement of the rollers, do not use oil or grease for lubrication as this will attract dust and cause the rollers to jam. The blade guide system is a consumable item and depending on usage will wear and need replacing.

When replacing components on the upper guide assembly first ensure that the blade is removed. Undo screws (Fig. 14.5, A) & then remove the whole assembly. Individual components can then be changed

Once the new components have been changed & the upper guide assembly refitted the blade should be refitted and the guides adjusted.

When replacing components on the lower guide assembly first ensure that the blade is removed. Undo screws (Fig. 14.6, A) & then remove the blade guard. You are now able to remove nut (Fig. 14.6, B) & remove the whole assembly. Individual components can now be changed.

Once the new components have been changed & the lower guide assembly & blade guard refitted the blade should be refitted.

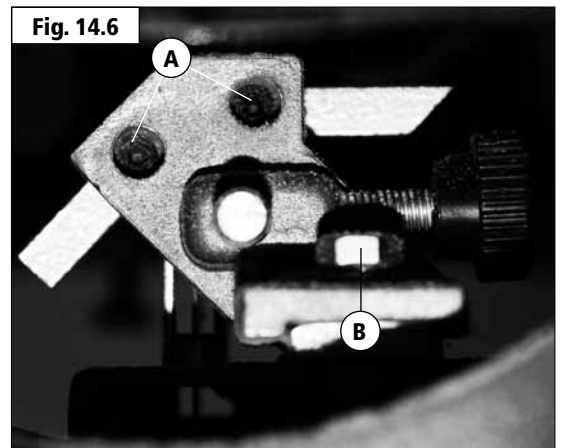
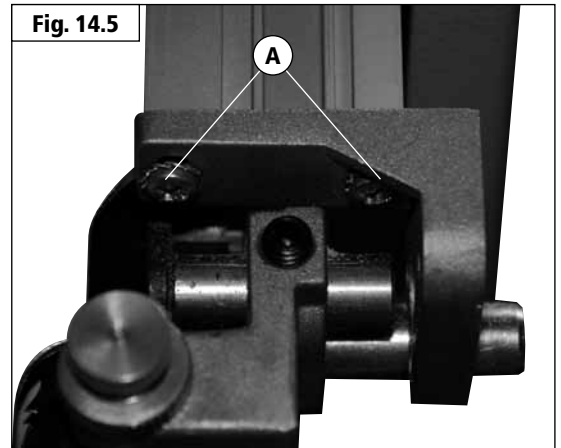

14. Maintenance - Cont.

The Table Insert

The table insert on a bandsaw is a consumable item (Fig. 14.8) and will therefore need replacing periodically. This procedure should be carried out with the bandsaw blade removed. To replace the table insert simply push the old insert out from underneath the table and fit the new one into position.

The Bandwheel Tyres

The bandwheels on this machine have rubber tyres fitted to the outer rim of the wheel (Fig. 14.9) to protect the set of the blade when in use, also to provide drive and to stop the blade slipping. As part of your regular service schedule inspect the tyres for wear and damage and replace if necessary. Again this is a consumable part of the bandsaw and will need replacing periodically depending on usage.

First remove the blade from the bandsaw, then remove the bandwheel. Gently ease the existing tyre from the rim taking care not to damage the bandwheel. To fit the new tyre it is a good idea to heat the tyre first in hot water, this softens the rubber up and makes it easier to stretch it over the bandwheel. The tyres before stretching are much smaller than the bandwheel and a good deal of stretching is required to make them fit. It is advisable to get help from a second person who can insert the wheel into the tyre while it is fully stretched.

The Bandwheel Bearings

The bandwheel bearings are sealed for life units which will need replacing periodically depending on usage.

To replace the bearings; first ensure that there is no blade fitted. Now remove the circlip from the hub and remove the bandwheel (circlip pliers will be required to carry out this operation), you will notice that there are two separate bearings fitted in the hub pressed up against each other. Take a brass drift (or similar) and tap one of the bearings out, the second bearing should now be able to be pushed out.

When fitting the new bearings; position by hand in the wheel hub and tap in until the bearing seats against the ridge in the casting (Fig. 14.10).

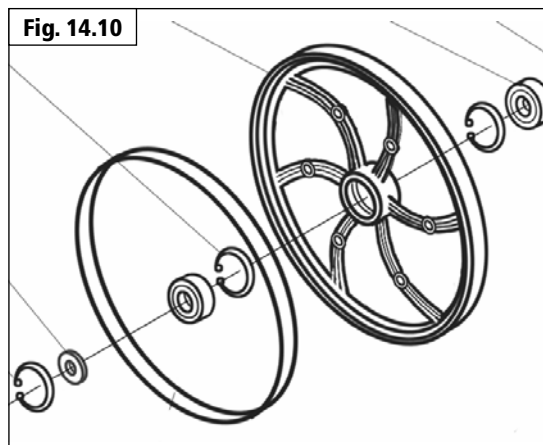
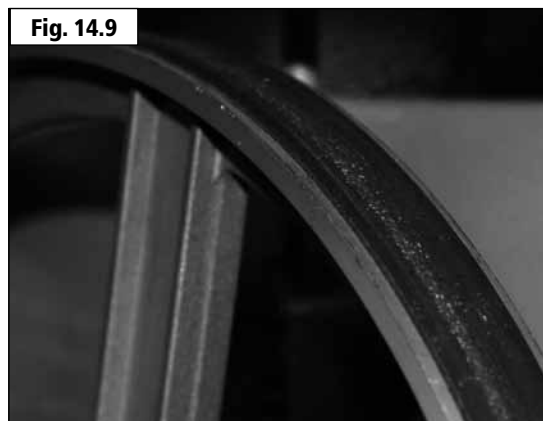
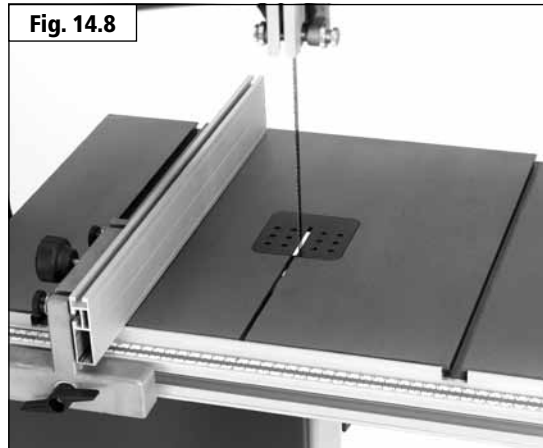

14. Maintenance - Cont.

Cleaning the Table

The table is ground from cast iron and if cared for properly will provide smooth accurate performance. Obviously when machining wood a certain amount of resin will be deposited on the surface, to ensure optimum performance the table needs to be properly cleaned at regular intervals.

Firstly brush off all loose particles, then wipe clean with white spirit ensuring that any resin build up is dispersed and removed. Once the table has been thoroughly cleaned it can now be treated with CWA195 silicone spray or wax. If these guidelines are followed the timber will glide smoothly and accurately across the table.

The Bandwheel Brush

The purpose of this brush is to remove any excess sawdust and resin from the bandwheel and tyre (Fig. 14.11). This brush will need adjusting periodically depending on usage. Before each use inspect the brush and make sure it is making sufficient contact with the bandwheel to remove sawdust from the tyre. The brush should be touching but not applying pressure to the wheel. If it isn't; loosen the fixing and adjust accordingly so it makes contact with the wheel. When the brush cannot be adjusted any nearer the wheel due to the bristles being worn then it must be replaced. Periodically the brush may also become clogged up with resin (this is especially common when cutting a long run of soft wood) if this occurs this resin must be scraped off as performance of the brush will be reduced.

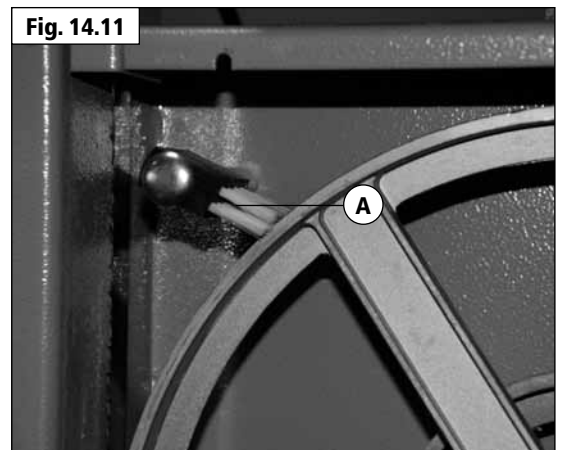

15. Troubleshooting

Symptom	Possible Causes	Solutions
Will not cut in a straight line	<ol style="list-style-type: none"> 1. Blade is worn 2. Guide carrier set too high 3. Blade tension not correct 4. Fence not aligned correctly 5. Table not aligned correctly 	<ol style="list-style-type: none"> 1. Change blade (see section 12 in the manual) 2. Adjust guide carrier 3. Refer to section 6 in the manual 4. Adjust (see section 4 in the manual) 5. Undo the four bolts holding the table to the trunnion and align table
Fence is not square	Fence not aligned correctly	Adjust (see section 7 in the manual)
Motor slows down when wood is put through	<ol style="list-style-type: none"> 1. Too much pressure being applied to the work piece 2. Drive belt slipping 3. Fence not aligned 4. Table not aligned correctly 5. Wrong type of blade 	<ol style="list-style-type: none"> 1. See section 9 in the manual 2. Adjust (see section 7 in the manual) 3. Adjust (see section 4 in the manual) 4. Undo the four bolts holding the table to the trunnion and align table 5. Change blade (see section 9 in the manual)
Machine stops when I let go of the on/off button	Faulty switch	Change switch
Machine buzzes but will not run	<ol style="list-style-type: none"> 1. Capacitor on motor is faulty 2. Fault within motor 	<ol style="list-style-type: none"> 1. Change capacitor 2. Have motor inspected and replace if needed
Unsure of which type of blade to use		Refer to section 12 in the manual
How much tension should be put on the blade?		Refer to section 12 in the manual
Cannot get the blade on		Ensure you have fully released the blade tension knob before trying to remove the blade
Cannot tension the blade, when it is on it runs out of thread		Check you have the correct blade length
Blade will not cut the wood	<ol style="list-style-type: none"> 1. Blade upside down 2. Blade back to front 	<ol style="list-style-type: none"> 1. Refer to section 12 in the manual 2. Refer to section 12 in the manual

16. Parts Lists & Diagrams

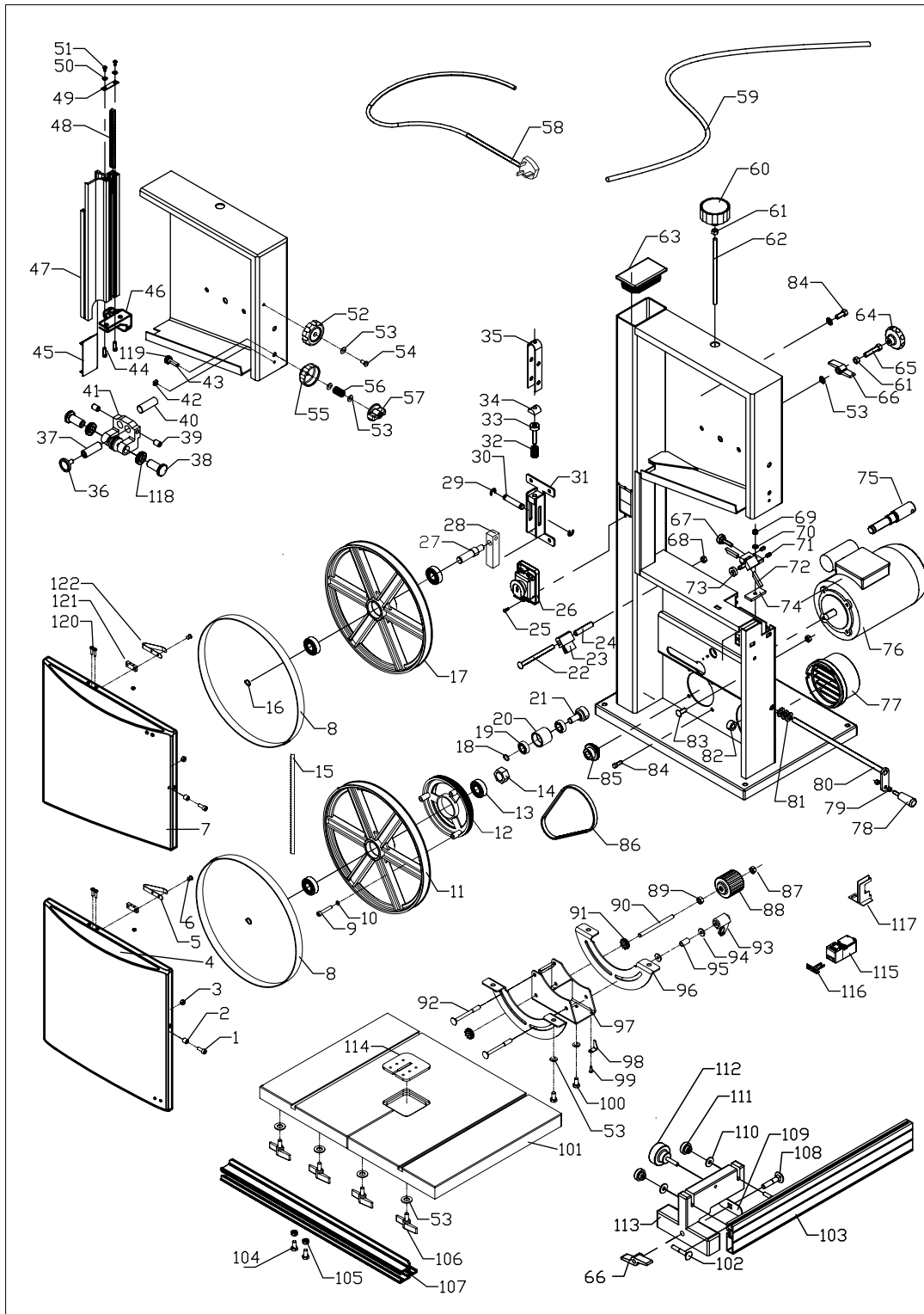

16. Parts Lists & Diagrams - Cont.

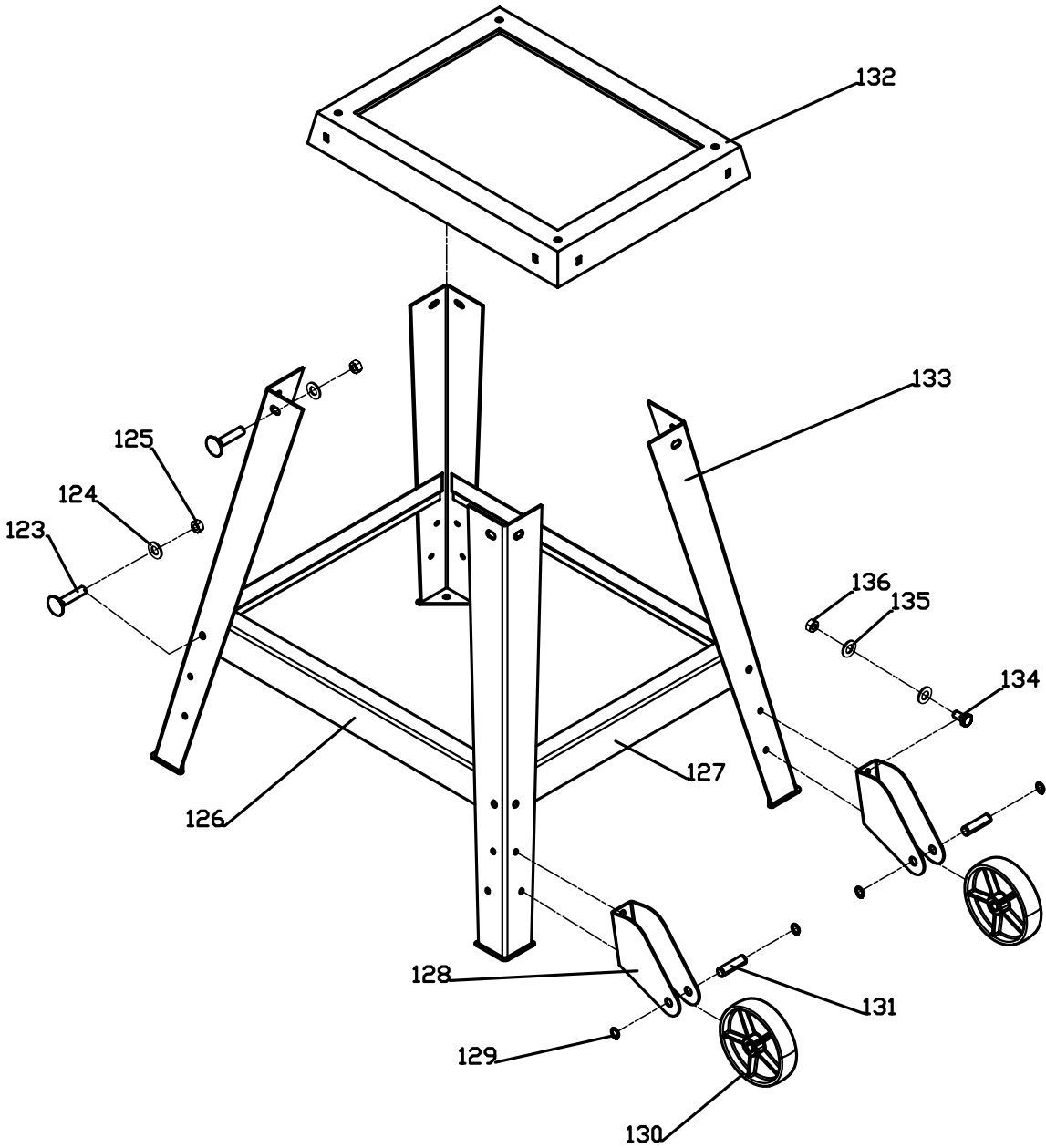

16. Parts Lists & Diagrams - Cont.

No.	Part Number	Part Name	Quantity
1	SBS12-1	Hexagon socket cap head screw	2
2	SBS12-2	Spacer bush	2
3	SBS12-3	Hx. Hd. Lock nut	2
4	SBS12-4	Lower door assembly	1
5	SBS12-5	Leaf spring-rear lock	2
6	SBS12-6	Rivet	4
7	SBS12-7	Upper door assembly	1
8	SBS12-8	Band saw tyre	2
9	SBS12-9	Hexagon socket cap head screw	3
10	SBS12-10	Spring washer	3
11	SBS12-11	Lower band wheel	1
12	SBS12-12	Pulley for lower band wheel	1
13	SBS12-13	Deep groove ball bearing	4
14	SBS12-14	Hexagon nut	1
15	SBS12-15	Blade (*Various options available)	1
16	SBS12-16	Spring washer	1
17	SBS12-17	Upper band wheel	1
18	SBS12-18	Spring washer	1
19	SBS12-19	Deep groove ball bearing	2
20	SBS12-20	Tension wheel	1
21	SBS12-21	Sliding shaft	1
22	SBS12-22	Cup square neck bolt	1
23	SBS12-23	Brush assembly	1
24	SBS12-24	Spacer bush	1
25	SBS12-25	Cross pan head screw	2
26	SBS12-26	NVR switch with emergency stop cover	1
27	SBS12-27	Upper wheel shaft	1
28	SBS12-28	Wheel carrier bracket	1
29	SBS12-29	C Ring	2
30	SBS12-30	Parallel pin	1
31	SBS12-31	Tension bracket frame	1
32	SBS12-32	Disc spring set	24
33	SBS12-33	Shaft	1
34	SBS12-34	Nut	1
35	SBS12-35	Tension bracket	1
36	SBS12-36	Guide Roller	3
37	SBS12-37	Shaft for pilot	1
38	SBS12-38	Knurled thumb screw	2
39	SBS12-39	Hexagonal screw	2

No.	Part Number	Part Name	Quantity
40	SBS12-40	Parallel pin	1
41	SBS12-41	Roller guide housing	1
42	SBS12-42	Pilot block	2
43	SBS12-43	Shaft for gear	1
44	SBS12-44	Pan head tapping screw	2
45	SBS12-45	Sliding board	1
46	SBS12-46	Roller guide seat	1
47	SBS12-47	Guide carrier extrusion	1
48	SBS12-48	Rack	1
49	SBS12-49	Cover board	1
50	SBS12-50	Serrated washer	2
51	SBS12-51	Pan head tapping screw	2
52	SBS12-52	Door locking knob	2
53	SBS12-53	Washer	2
54	SBS12-54	Hexagon socket cap head screw	2
55	SBS12-55	Adjusting knob	1
56	SBS12-56	Compressor spring	1
57	SBS12-57	Locking Knob	1
58	SBS12-58	Cable & plug assembly	1
59	SBS12-59	Motor cable	1
60	SBS12-60	Tension knob	1
61	SBS12-61	Hexagon nut	2
62	SBS12-62	Tensioning shaft	1
63	SBS12-63	Plastic end cap for column	1
64	SBS12-64	Adjusting knob	1
65	SBS12-65	Hexagon bolt	1
66	SBS12-66	Wing Nut	2
67	SBS12-67	Idler wheel shaft	1
68	SBS12-68	Hexagon flange nut	1
69	SBS12-69	Hx. Hd. Lock nut	1
70	SBS12-70	Washer	1
71	SBS12-71	Hexagonal screw	2
72	SBS12-72	Pilot pin	2
73	SBS12-73	Deep groove ball bearing	1
74	SBS12-74	Lower guiding piece pad	1
75	SBS12-75	Lower wheel shaft	1
76	SBS12-76	Motor	1
77	SBS12-77	Suction connector	1
78	SBS12-78	Crank handle	1
79	SBS12-79	Hexagon nut	12

16. Parts Lists & Diagrams - Cont.

No.	Part Number	Part Name	Quantity
80	SBS12-80	Crank	1
81	SBS12-81	Washer	3
82	SBS12-82	Set collar	1
83	SBS12-83	Serrated lock washer	4
84	SBS12-84	Hexagon bolt	4
85	SBS12-85	Motor pulley	1
86	SBS12-86	Drive belt	1
87	SBS12-87	Hx. Hd. Lock nut	1
88	SBS12-88	Adjust knob	1
89	SBS12-89	Hexagon nut	12
90	SBS12-90	Gear shaft	1
91	SBS12-91	Gear	2
92	SBS12-92	Serrated lock washer	2
93	SBS12-93	Locking knob	1
94	SBS12-94	Washer	3
95	SBS12-95	Spacer bush	1
96	SBS12-96	Table trunnion plate	2
97	SBS12-97	Table trunnion support casting	1
98	SBS12-98	Pointer	1
99	SBS12-99	Cross pan head screw	1
100	SBS12-100	Hexagon bolt	4
101	SBS12-101	Band saw table	1
102	SBS12-102	Cup square neck bolt	2
103	SBS12-103	Fence extrusion	1
104	SBS12-104	Hexagon bolt	2
105	SBS12-105	Nut	2
106	SBS12-106	Thumb screw	4
107	SBS12-107	Rip fence carrier extrusion	1
108	SBS12-108	Cup square neck bolt	1

No.	Part Number	Part Name	Quantity
109	SBS12-109	Bolt guide plate	1
110	SBS12-110	Washer	2
111	SBS12-111	Knurled nut	2
112	SBS12-112	Star knob	1
113	SBS12-113	Rip fence carrier	1
114	SBS12-114	Table insert	1
115	SBS12-115	Microswitch	2
116	SBS12-116	Key	2
117	SBS12-117	Saw blade guard (lower)	1
118	SBS12-118	Nut	2
119	SBS12-119	Gear	1
120	SBS12-120	Cross pan head screw	4
121	SBS12-121	Joining block	2
122	SBS12-122	Nut	4
123	SBS12-123	Cup square neck bolt	16
124	SBS12-124	Washer	24
125	SBS12-125	Nut	25
126	SBS12-126	Long stretcher plate	2
127	SBS12-127	Short stretcher plate	2
128	SBS12-128	Wheel support bracket	2
129	SBS12-129	Spring washer	4
130	SBS12-130	Wheel	2
131	SBS12-131	Wheel axis	2
132	SBS12-132	Top plate	1
133	SBS12-133	Support leg	4
134	SBS12-134	Hexagon bolt	4
135	SBS12-135	Washer	8
136	SBS12-136	Nut	4

EU Declaration of Conformity

Cert No: EU / BS12 / 1

RECORD POWER LIMITED,
Unit B, Ireland Industrial Est.
Adelphi Way, Staveley, Chesterfield S43 3LS
declares that the machinery described:-

1. Type: **Bandsaw**
2. Model No: **BS12**
3. Serial No

Conforms with the following directives:-

MACHINERY DIRECTIVE	2006/42/EC
LOW VOLTAGE DIRECTIVE	2006/95/EC
ELECTROMAGNETIC COMPATIBILITY DIRECTIVE	2004/108/EC EN 55014-1:2006 EN 61000-3-2:2006 EN 61000-3-3:1995+A1+A2 EN 55014-2:1997+A1

and conforms to the machinery example for which the
EC Type-Examination Certificate No. **AE501473510001, BM501639890001**
has been issued by **TUV Rheinland Product Safety GmbH,**
at: Am Grauen Stein, D-51105. Cologne, Germany

and complies with the relevant essential health and safety requirements.

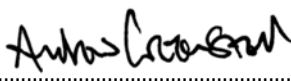
Signed..........Dated: **01/02/12**
Andrew Greensted
Managing Director

Visit
www.recordpower.co.uk
for the full range of
Record Power products.



Woodworking Machinery



Blades



Craft Accessories



Finishes and Waxes



DVDs



Accessories



RECORD POWER
ESTABLISHED 1909

Woodworking Machines & Accessories

Record Power Limited
Unit B, Adelphi Way
Ireland Industrial Est.
Staveley S43 3LS

Telephone: 01246 561 520
Facsimile: 01246 561 537

Email: sales@recordpower.co.uk
www.recordpower.co.uk