

RECORD POWER
ESTABLISHED 1909®

Original Instruction Manual

WG250 Wet Stone Sharpening System

Version 3.0
November 2012

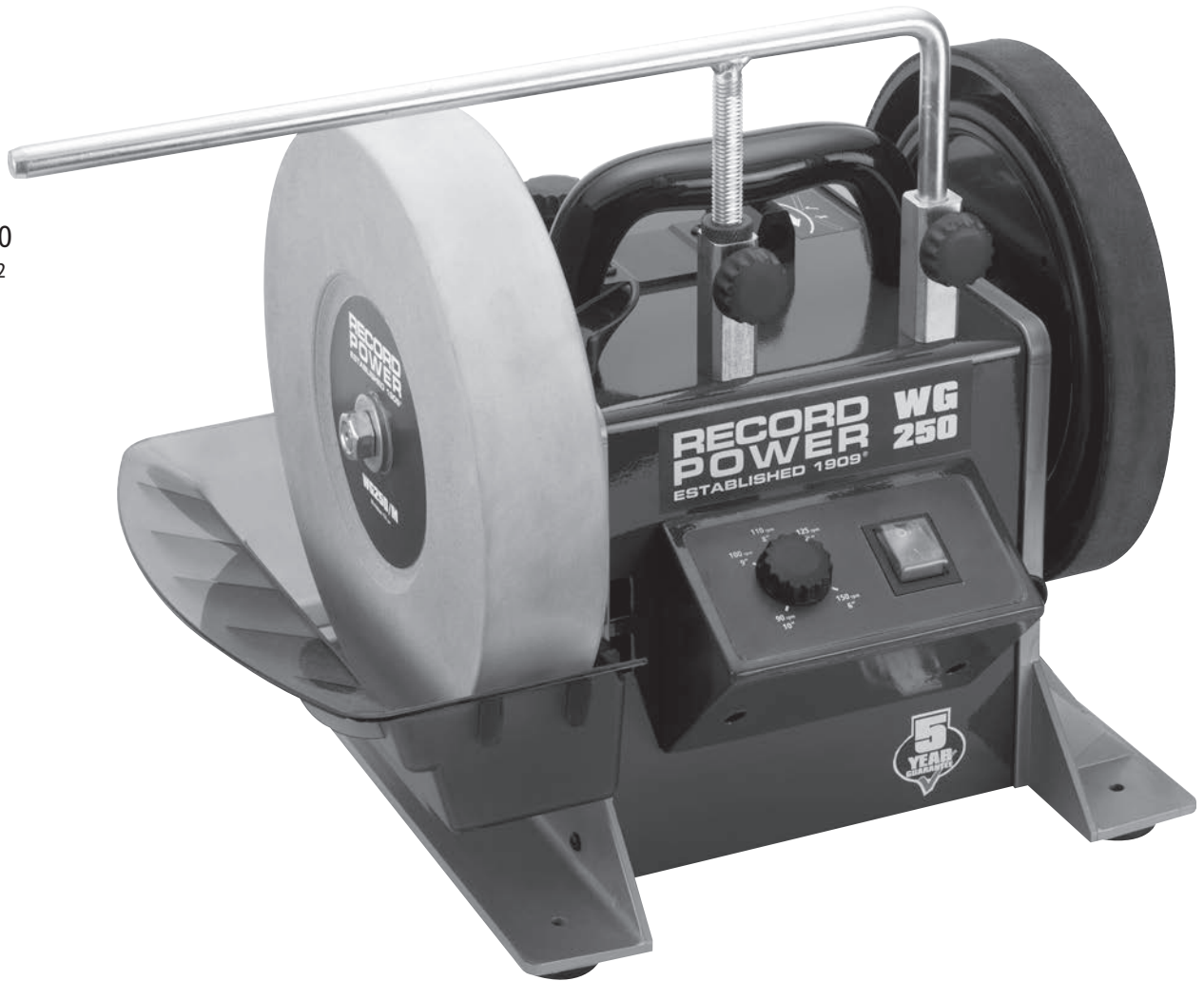

To register this product please visit
www.recordpower.info

It is important to register your product as soon as possible in order to receive efficient after sales support and be entitled to the full **5 year guarantee**. Your statutory rights are not affected.
Please see back cover for contact details.



Always wear safety glasses when using woodworking equipment.



Always read the instructions provided before using woodworking equipment.

Important

For your safety read instructions carefully before assembling or using this product.

Save this manual for future reference.

Contents

1. Explanation of Symbols
 2. General Health & Safety Guidance
 3. Additional Health & Safety for Wet Stone Sharpeners
 4. Record Power Guarantee
 5. Specifications
 6. Unpacking & Checking Contents
 7. Getting to Know Your Machine
 8. Assembly
 9. Set up and Adjustment
 10. Optional Jigs for the WG250 Wet Stone Sharpener
 - 10.1 **WG250/G** Short Knife Jig
 - 10.2 **WG250/H** Long Knife Jig
 - 10.3 **WG250/A** Gouge Jig
 - 10.4 **WG250/B** Short Tool Jig
 - 10.5 **WG250/E** Scissor Jig
 - 10.6 **WG250/D** Plane Camber Jig
 - 10.7 **WG250/J** Axe Jig
 - 10.8 **WG250/C** Straight Edge Jig
 - 10.9 **WG250/I** Tool Rest Jig
 - 10.10 **WG250/F** Side Wheel Sharpening Jig
 - 10.11 **WG250/O** Support Arm Extension Kit
 11. Maintenance
 12. Troubleshooting
 13. Electrical Connection & Wiring Diagram
 14. Parts Lists & Diagrams
- EU Certificate of Conformity



WARNING: This product is heavy and as a precaution it is advised that two people assemble the machine.

1. Explanation of Symbols

The symbols and their meanings shown below may be used throughout this manual. Please ensure that you take the appropriate action wherever the warnings are used.

Mandatory Instructions



Read and fully understand the instruction manual before attempting to use the machine.



Indicates an instruction that requires particular attention



Wear protective eyewear



Use respiratory protective equipment



Use hearing protection



Use suitable protective footwear



Use protective work gloves

Warnings



Indicates a risk of severe personal injury or damage to the machine



Indicates a risk of severe personal injury from electrical shock



Risk of personal injury from lifting of heavy items



Indicates a risk of severe personal injury from airborne objects



Risk of fire

2. General Health & Safety Guidance

Ensure that you carefully read and fully understand the instructions in this manual before assembly, installation and use of this product. Keep these instructions in a safe place for future reference.

WARNING: for your own safety, do not attempt to operate this machine until it is completely assembled and installed according to these instructions.

WARNING: When using any machine, basic safety precautions should always be followed to reduce the risk of fire, electric shock and personal injury.

Safe Operation

1. Use Personal Protective Equipment (PPE)

- The operation of any machine can result in foreign objects being thrown into your eyes, which can result in severe eye damage. Protective eyewear or other suitable eye protection or face shield should be used at all times. Everyday spectacles only have impact resistant lenses. They are not protective eyewear and do not give additional lateral protection.
- Use respiratory protective equipment (dust mask etc.) if the machining operation creates dust. Exposure to high levels of dust created by machining hardwoods, softwoods and man made composite boards can result in serious health problems. Some imported hardwoods give off highly irritating dust, which can cause a burning sensation. The use of respiratory protective equipment should not be seen as an alternative to controlling the risk of exposure at source by using adequate dust extraction equipment.
- The use of ear plugs or ear defenders is recommended when the machine is in use, particularly if the noise level exceeds 85 dB.
- Wear suitable protective gloves when handling cutting tools or blades. Gloves should NOT be worn when using the machine as they can be caught in moving parts of the machine.
- Non-slip safety footwear is recommended when using the machine and handling large work pieces.

2. Dress appropriately

- Do not wear loose clothing, neckties or jewellery; they can be caught in moving parts of the machine.
- Roll up long sleeves above the elbow.
- Wear protective hair covering to contain long hair.

3. Safety warnings

- Find and read any warning labels on the machine
- It is important that any labels bearing health and

safety warnings are not removed, defaced or covered. Replacement labels can be obtained by contacting our Customer Service Department.

4. Familiarise yourself with the machine

- If you are not thoroughly familiar with the operation of this machine, obtain advice from your supervisor, instructor, or other qualified person or contact your retailer for information on training courses. Do not use this machine until adequate training has been undertaken.

5. Take care when moving or positioning the machine

- Some machines can be very heavy. Ensure the floor of the area in which the machine is to be used is capable of supporting the machine.
- The machine and its various components can be heavy. Always adopt a safe lifting technique and seek assistance when lifting heavy components. In some cases it may be necessary to use mechanical handling equipment to position the machine within the work area.
- Some machines have optional wheel kits available to allow them to be manoeuvred around the workshop as required. Care should be taken to install these according to the instructions provided.
- Due to the nature of the design of some machines the centre of gravity will be high making them unstable when moved. Extreme care should be taken when moving any machine.

6. The machine should be level and stable at all times

- When using a leg stand or cabinet base that is designed to be fitted to the machine, always ensure that it is securely fastened to the machine using the fixings provided.
- If the machine is suitable to be used on a workbench, ensure that the workbench is well constructed and capable of withstanding the weight of the machine. The machine should always be securely fastened to the workbench with appropriate fixings.
- Where possible, floor standing machines should always be secured to the floor with fixings appropriate to the structure of the floor.
- The floor surface should be sound and level. All of the feet of the machine should make contact with the floor surface. If they do not, either re-locate the machine to a more suitable position or use packing shims between the feet and the floor surface to ensure the machine is stable.

2. General Health & Safety Guidance - cont.

7. Remove adjusting keys and wrenches

- Ensure that all adjusting wrenches and keys are removed before switching the machine 'ON'. There is a risk of severe personal injury or damage to the machine from airborne objects.

8. Before switching the machine 'ON'

- Clear the machine table of all objects (tools, scrap pieces etc.)
- Make sure there is no debris between the work piece and the table / work support.
- Ensure that the work piece is not pressed against, or touching the saw blade or cutting tool.
- Check all clamps, work holding devices and fences to ensure that they are secure and cannot move during machining operations.
- Plan the way that you will hold and feed the work piece for the entire machining operation.

9. Whilst machining

- Before starting work, watch the machine while it runs. If it makes an unfamiliar noise or vibrates excessively, switch the machine 'OFF' immediately and disconnect it from the power supply. Do not restart until finding and correcting the source of the problem.

10. Keep the work area clear

- Working clearances can be thought of as the distances between machines and obstacles that allow safe operation of every machine without limitation. Consider existing and anticipated machine needs, size of material to be processed through each machine and space for auxiliary stands and/or work tables. Also consider the relative position of each machine to one another for efficient material handling. Be sure to allow yourself sufficient room to safely operate your machines in any foreseeable operation.
- Cluttered work areas and benches create the risk of accidents. Keep benches clear and tidy away tools that are not in use.
- Ensure that the floor area is kept clean and clear of any dust and debris that may create trip or slip hazards.

11. Consider the work area environment

- Do not expose the machine to rain or damp conditions.
- Keep the work area well lit and ensure that there is artificial lighting available when there is insufficient natural light to effectively light the work area. Lighting should be bright enough to eliminate shadow and prevent eye strain.
- Do not use the machine in explosive environments eg. in

the presence of flammable liquids, gases or dust.

- The presence of high levels of dust created by machining wood can present a risk of fire or explosion. Always use dust extraction equipment to minimise the risk.

12. Keep other persons away (and pets)

- The machine is designed to be used by one person only.
- Do not let persons, especially children, touch the machine or extension cable (if used) and keep visitors away from the work area.
- Never leave the machine running unattended. Turn the power supply off and do not leave the machine unattended until it comes to a complete stop.
- If the work area is to be left unattended, all machinery should be switched 'OFF' and isolated from the mains power supply.

13. Store machines safely when not in use

- When not in use, machines should be stored in a dry place, out of reach of children. Do not allow persons unfamiliar with these instructions or with the machine to operate it.

14. Do not overreach

- Choose a working position that allows your body to remain balanced and feed the work piece in to the machine without overreaching.
- Keep proper footing and balance at all times.

15. Electrical supply

- Electrical circuits should be dedicated to each machine or large enough to handle combined motor amp loads. Power outlets should be located near each machine so that power or extension cables are not obstructing high-traffic areas. Observe local electrical guidelines for proper installation of new lighting, power outlets, or circuits.
- The machine must be connected to an earthed power supply.
- The power supply must be equipped with a circuit breaker that provides short circuit, overload and earth leakage protection.
- The voltage of the machine must correspond to the voltage of the mains power supply.
- The mains plug fitted to the machine should always match the power outlet. Do not modify the plug in any way. If a replacement plug is required it should be fitted by a competent person and of the correct type and rating for the machine.
- If you are unsure about any electrical connections always consult a qualified electrician.

2. General Health & Safety Guidance - cont.

16. Avoid unintentional starting of the machine

- Most machines are fitted with a no-volt release (NVR) switch to prevent unintentional starting. If in doubt always ensure the machine switch is in the 'OFF' position before connecting it to the power supply. This means the machine will not automatically start up after a power cut or switching on of the power supply, unless you first reset the start switch.

17. Outdoor use

- Your machine should not be used outdoors.

18. Extension cables

- Whenever possible, the use of extension cables is not recommended. If the use of an extension cable is unavoidable, then it should have a minimum core cross section of 2.5mm² and limited to a maximum length of 3 metres.
- Extension cables should be routed away from the direct working area to prevent a trip hazard.

19. Guard against electric shock

- Avoid body contact with earthed or grounded surfaces such as pipes and radiators. There is an increased risk of electric shock if your body is earthed or grounded.

20. Always work within the machine's intended capacities

- Operator safety and machine performance are seriously adversely affected if attempts to make the machine perform beyond its limits are made.

21. Do not abuse the power cable

- Never pull the power cable to disconnect it from the power socket. Always use the plug.
- Keep the power cable away from heat, oil and sharp edges.
- Do not use the power cable for carrying or moving the machine.

22. Secure the work piece

- Ensure that the work piece is securely held before starting to machine it.
- When working within 300 mm of the machining area, always use a push stick to feed the work piece in to the blade or cutting tool. The push stick should have a minimum length of 400 mm. If the push stick becomes damaged, replace it immediately.
- Use extra supports (roller support stands etc.) for any work pieces large enough to tip when not held down to the table top.
- Do not use another person as a substitute for a table

extension, or as additional support for a work piece that is longer or wider than the basic table, or to help feed, support, or pull the work piece.

- Do not attempt to machine more than one work piece at a time.
- When feeding the work piece towards the blade or cutting tool never position your hands in direct line of the cutting path. Avoid awkward operations and hand positions where a sudden slip could cause your hand or fingers to move into the machining area.

23. Stay alert

- Safety is a combination of operator common sense and alertness at all times when the machine is being used.
- Use all machines with extreme care and do not use the machine when you are tired or under the influence of drugs, alcohol or medication.

24. Use the correct tool for the job

- Do not use the machine for any purpose other than which it was designed.
- When selecting replacement cutting tools and blades, always ensure that they are designed to cut the material that you intend to use them for. If in any doubt seek further advice from the manufacturer.

25. Connect dust extraction equipment

- Always use dust extraction equipment. The dust extractor should be of suitable size and capacity for the machine that it is connected to and have a filtration level appropriate to the type of waste being collected. Refer to the relevant section of the manual for details of the specific dust extraction requirements for this machine.
- The dust extractor should be switched 'ON' before starting the machine that it is connected to. The dust extractor should be left running for 30 seconds after the last machining operation is complete in order to clear any residual waste from the machine.

26. Ensure that the machine is correctly guarded

- Never use the machine if any of the standard safety guards and equipment are removed or damaged.
- Some machines incorporate safety interlocks to prevent the machine from being used without the guards in place. Never attempt to bypass or modify the interlocks to allow the machine to be used without the guards in place.

27. Maintain your machine with care

- This manual gives clear instructions on installation, set up and operation of the machine and also details any routine and preventative maintenance that should be

2. General Health & Safety Guidance - cont.

performed periodically by the user.

- Remember always to switch off and unplug the machine from the power supply before carrying out any setting up or maintenance operations.
- Follow any instructions for the maintenance of accessories and consumables.
- Do not use compressed air to clean the machine. Always use a brush to dislodge dust in places that are awkward to reach and a dust extractor to collect the waste.
- Inspect electric cables periodically and, if damaged, have them replaced by an authorised service facility or qualified electrician.
- Inspect extension cables (if used) periodically and replace if damaged.

28. Keep cutting tools sharp and clean

- Correctly maintained cutting tools are easier to control and less likely to bind.
- Cutting tools and blades can become hot during use. Take extreme care when handling them and always allow them to cool before changing, adjusting or sharpening them.

29. Disconnect the machine from the power supply

- When not in use, before servicing, changing blades etc. always disconnect the machine from the power supply.

30. Check for damaged parts

- Before each use of the machine, it should be carefully checked to determine that it will operate properly and perform its intended function.

- Check for alignment of moving parts, binding of moving parts, breakage of parts and any other conditions that may affect the operation of the machine.
- A guard or other part that is damaged should be properly repaired or replaced by a qualified person unless otherwise indicated in this instruction manual.
- Do not use the machine if the switch does not turn the machine 'ON' and 'OFF'.
- Have defective switches replaced by a qualified person.

31. Warning!

- The use of any accessory or attachment, other than those recommended in this instruction manual, or recommended by our Company may present a risk of personal injury or damage to the machine and invalidation of the warranty.

32. Have your machine repaired by a qualified person

- This machine complies with the relevant safety rules and standards appropriate to its type when used in accordance with these instructions and with all of the standard safety guards and equipment in place. Only qualified persons using original spare parts should carry out repairs. Failure to do this may result in considerable danger to the user and invalidation of warranty.

33. Caution! Motor may become hot during use

- It is normal for motors on some machines to become hot to the touch during use. Avoid touching the motor directly when in use.

3. Additional Health & Safety for Wet Stone Sharpeners

Safe Operation

- The wet stone sharpener should be level and stable at all times.
- The machine should be placed on a suitable workbench. Depending on the sharpening application, access will be required to both sides of the grinder, so it is not practical to fix the machine to the work bench.
- When positioning the machine on the bench, ensure that there are no objects between the base of the machine and the bench surface and that all four feet of the machine make contact with the bench.

2. Familiarise yourself with the machine

- Although the wet stone sharpener runs at relatively low speed, there are still risks present that can lead to accidents. Most accidents with this type of machine involve trapping of fingers or hands between the exposed sharpening stone or honing wheel and the body of the machine, or loose clothing being drawn in to the moving parts. In addition there is the risk of injury from the sharp edges of the tool.
- The risk of breakage is inherent in every abrasive wheel. The level of risk is lower with slow speed grinders. Always handle grinding wheels with extreme care. They are brittle and the slightest impact can cause fractures within the stone.
- This machine is designed for the sharpening and honing of tools, knives, chisels, axes etc made of metal. It should not be used for any other purpose.
- The machine and particularly the sharpening stone should be protected from frost. If the water retained within the stone freezes it can cause the stone to crack. If the machine is not to be used for long period, empty the water trough, remove the sharpening stone and store it in a dry place at temperatures above 5°C.

3. Before switching the machine 'ON'

- Select the correct jig or fixture for holding the tool to be sharpened. The manual details all of the jigs available for the machine and the correct method of using them.
- Take the time to ensure that the jig is set correctly to achieve the correct sharpening angle for the application and that the fixings are secure.
- Check that there is sufficient water in the trough to keep the stone wet whilst sharpening. If the stone is dry, it will soak up approximately 0.5 litres of water in the first few minutes of running.
- Check the condition of the stone. If damaged or cracked replace the stone immediately.
- Rotate the stone by hand to ensure that it can move freely without interference from other components.

- Check that the speed control is set to correspond with the diameter of the sharpening stone mounted on the machine.

4. Whilst sharpening / honing:

- When the machine is first switched 'ON', allow it to run for up to a minute before applying the work piece.
- Regularly check the water level and top up as necessary. It may take several minutes before the sharpening stone is fully saturated and for the water level to remain constant.
- Certain sharpening applications may need to be carried out on the side of the stone. It is safe to use the side of the stone for sharpening providing that the 'side jig' is used for control of the work piece.
- When honing, always have the honing wheel running away from the edge of the tool. Never attempt to hone towards the edge as the tool will dig in to the honing wheel and may be thrown from the machine and the honing wheel damaged.

5. Maintenance

- Regularly check the condition of the surface of the sharpening stone. The compound of the stone is quite soft and grooves can wear in to the face of the stone quite easily. Dress the stone regularly as described in the manual. Do not attempt to apply the dressing tool to the honing wheel.
 - If steel is exposed to water for prolonged periods, rust will form. If rust forms on any of the exposed components of the machine, they should be cleaned and lubricated to prevent further damaged.
 - The dust from abrasive wheels can be an irritant and a hazard to your health. As the sharpening stone runs at slow speed and in water, the risk from air borne dust whilst sharpening is minimal. However, waste dust will collect in the water trough and there is a risk of exposure as the trough dries out. Always use the machine in a well ventilated area and use additional respiratory protective equipment when cleaning the machine. When the machine is dry clean it with a vacuum cleaner to remove waste material.
6. This machine falls under the scope of the 'Health & Safety at Work etc. Act 1974', and the 'Provision & Use of Work Equipment Regulations 1998'. We recommend that you study and follow these regulations.

Further guidance can be found in the 'Safety in the use of abrasive wheels – publication HSG17' published by Health & Safety Executive and available from their website www.hse.gov.uk.

4. Record Power Guarantee

“**Products**” means the Products sold by Record Power subject to these terms and conditions;

“**Record Power**” is Record Power Limited, whose company registration number is 4804158 and registered office address is Unit B, Ireland Industrial Estate, Adelphi Way, Staveley, Chesterfield, S43 3LS and sells through a network of Authorised Dealers;

“**Authorised Distributor**” is the nominated importer for your region who will generally sell through a network of Authorised Dealers. Details of Authorised Distributors for specific countries can be found in the Product manual or at www.recordpower.info;

“**Authorised Dealer**” is a retailer or business authorised to sell Record Power Products to end users.

1 Guarantee

- 1.1 Record Power guarantees that for a period of 5 years from the date of purchase the components of qualifying Products (see clauses 1.3.0 to 1.2.9) will be free from defects caused by faulty construction or manufacture.
- 1.2 During this period Record Power, its Authorised Distributor or Authorised Dealer will repair or replace free of charge any parts which are proved to be faulty in accordance with paragraphs 1.1 above provided that:
 - 1.3.0 you follow the claims procedure set out in clause 2 below;
 - 1.2.2 Record Power, our Authorised Distributor or Authorised Dealer are given a reasonable opportunity after receiving notice of the claim to examine the Product;
 - 1.2.3 if asked to do so by Record Power, its Authorised Distributor or Authorised Dealer, you return the Product, at your own cost, to Record Power’s premises or other approved premises such as those of the Authorised Distributor or supplying Authorised Dealer, for the examination to take place;
 - 1.2.4 the fault in question is not caused by industrial use, accidental damage, fair wear and tear, wilful damage, neglect, incorrect electrical connection, abnormal working conditions, failure to follow our instructions, misuse, or alteration or repair of the Product without our approval;
 - 1.2.5 the Product has been used in a domestic environment only;
 - 1.2.6 the fault does not relate to consumable Products such as blades, bearings, drive belts or other wearing parts which can reasonably be expected to wear at different rates depending on usage (for full details contact Record Power or your local

Authorised Distributor);

- 1.2.7 the Product has not been used for hire purposes, by you or by a previous owner;
 - 1.2.8 the Product has been purchased by you as the guarantee is not transferable from a private sale.
 - 1.2.9 where the Product has been purchased from a retailer, the 5 year guarantee is transferable and begins on the date of the first purchase of the Product and in the event of a claim under this guarantee proof of the original purchase date will be required to validate the warranty period.
- ### 2 Claims Procedure
- 3.0 In the first instance please contact the Authorised Dealer who supplied the Product to you. In our experience many initial problems with machines that are thought to be due to faulty parts are actually solved by correct setting up or adjustment of the machines. A good Authorised Dealer should be able to resolve the majority of these issues much more quickly than processing a claim under the guarantee.
 - 2.2 Any damage to the Product resulting in a potential claim under the guarantee must be reported to the Authorised Dealer from which it was purchased within 48 hours of receipt.
 - 2.3 If the Authorised Dealer who supplied the Product to you has been unable to satisfy your query, any claim made under this Guarantee should be made directly to Record Power or its Authorised Distributor (for details of the Authorised Distributor in your country please see your Product manual or check www.recordpower.info for details). The claim itself should be made in a letter setting out the date and place of purchase, and giving a brief explanation of the problem which has led to the claim. This letter should then be sent with proof of the purchase date (preferably a receipt) to Record Power or its Authorised Distributor. If you include a phone number or email address this will help to speed up your claim.
 - 2.4 Please note that it is essential that the letter of claim reaches Record Power or its Authorised Distributor on the last day of this Guarantee at the latest. Late claims will not be considered.
- ### 3 Limitation of Liability
- 3.1 We only supply Products for domestic and private use. You agree not to use the Product for any commercial, business or re-sale purposes and we have no liability to you for any loss of profit, loss of business, business interruption or loss of business opportunity.

4. Record Power Guarantee

3.2 This Guarantee does not confer any rights other than those expressly set out above and does not cover any claims for consequential loss or damage. This Guarantee is offered as an extra benefit and does not affect your statutory rights as a consumer.

4 Notice

This Guarantee applies to all Products purchased from an Authorised Dealer of Record Power within the United Kingdom of Great Britain and Northern Ireland. Terms of Guarantee may vary in other countries – please check with the Authorised Distributor in your country (details of the Authorised Distributor for your country can be found in the manual or at www.recordpower.info).

5. Specifications

Motor:	230V / 50Hz / 160W
Full load current:	0.7 A
No load speed:	90 - 150 min ⁻¹
Grinding wheel size:	250 x 50mm
Honing wheel diameter:	230 x 30 mm
Grinding wheel bore:	12mm
Acoustic power level LWA:	74 dB (A)
Acoustic pressure level LPA:	68,7 dB (A)
Package size:	495 x 385 x 420 mm
Weight:	14.2 kg

6. Unpacking & Checking Contents

1. The machine is designed to operate in closed rooms and must be placed stable on firm and levelled surface.
2. The machine can be bolted down if required.
3. For packing reasons the machine is not completely assembled.

Contents of Package

1. Leather honing wheel 230mm
 2. Slow speed wet stone sharpener
 3. Sharpening Stone 250mm diameter, 250 grit
 4. Water tank
 5. Support arm
 - 6 Straight edge jig
 7. Stone grader
 8. Honing compound
 9. Angle setting gauge
 10. Angle finder
- Operating manual (not shown)

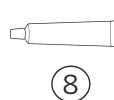
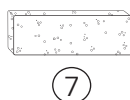
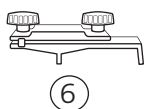
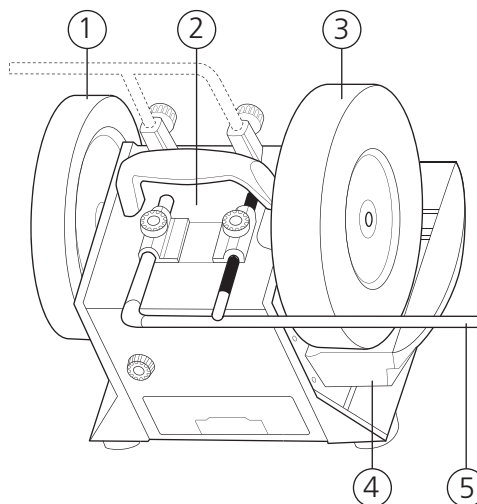

7. Getting to Know Your Machine

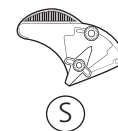
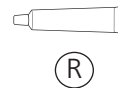
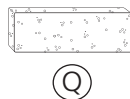
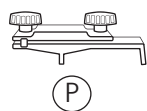
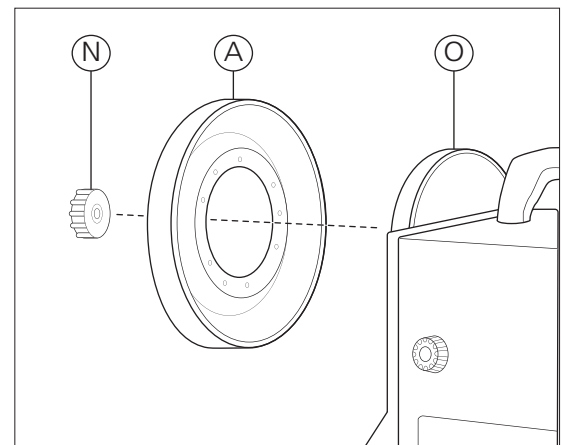
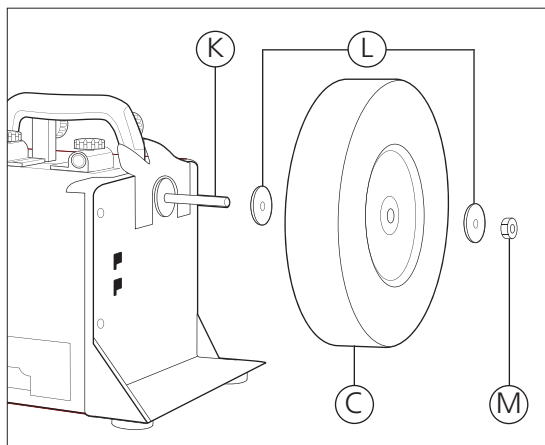
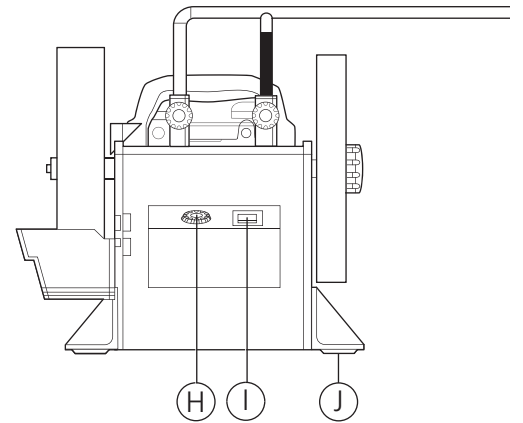
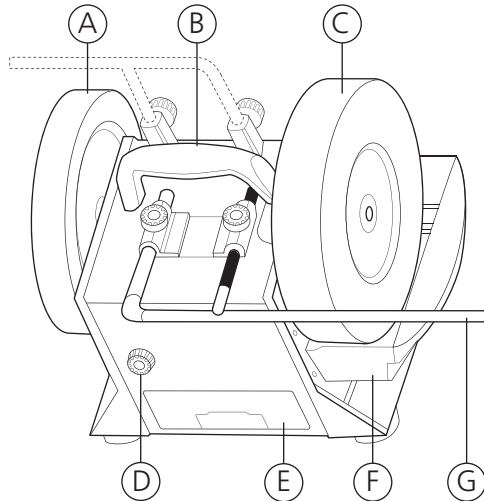

Item	Description	Quantity	Item	Description	Quantity
A	Leather honing wheel	1	K	Shaft	1
B	Carrying handle	1	L	Washer	1
C	Sharpening Stone	1	M	Lock nut	1
D	Torque adjust knob	1	N	Lock knob	1
E	Storage drawer	1	O	Friction drive wheel	1
F	Water tank	1	P	Straight edge Jig	1
G	Support arm	1	Q	Stone grader	1
H	Speed adjust knob	1	R	Honing compound	1
I	ON/OFF switch	1	S	Angle setting gauge	1
J	Rubber feet	1	T	Angle finder	1

8. Assembly

- If you notice any transport damage while unpacking, notify the supplier immediately.
- Dispose of the packing in an environmentally friendly manner.
- Clean all rust protected surfaces with a mild solvent.

Remove the Transport Lock

There is a foam block inside the machine that is used during shipment to keep the motor shaft from resting on the drive wheel.

Please remove the storage drawer (E), turn the machine on its side, and remove the internal foam block before operating.



Note:

To protect the drive wheel in transit, a plastic sleeve is fitted to the motor shaft. This sleeve must be removed before attempting to use the machine. It is necessary to unscrew the torque adjusting knob to release the pressure of the motor shaft against the drive wheel and then remove the honing wheel to gain access to the motor shaft. See opposite.

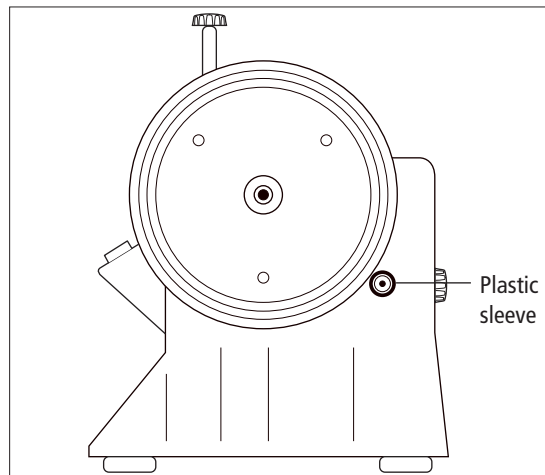

Mount the Sharpening Stone

1. Install the Sharpening Stone (C) on the shaft (K).
2. Place a washer (L) on each side of the Sharpening Stone and tighten the lock nut (M).



Note:

That the lock nut (M) has a left hand thread i.e. turn clockwise to loosen, turn anti-clockwise to tighten.

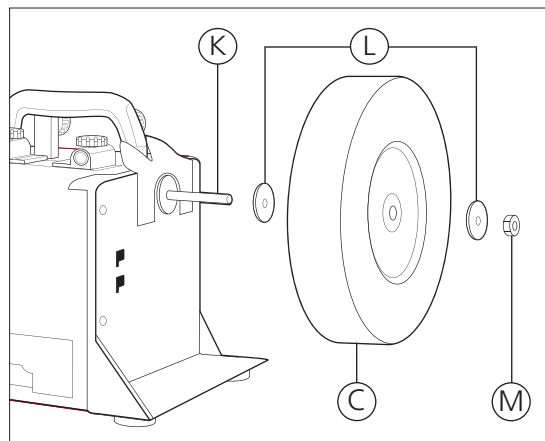

8. Assembly - Cont.



For the machine to perform correctly and produce an accurate cutting edge it is important that the sharpening stone runs as true as possible. The total maximum tolerances for run out of the stone are as detailed below:

Radial (up and down): 0.35 mm

Axial (side to side): 0.8 mm

During the production process, the stone is mounted to the machine to ensure that it runs true and within the tolerances quoted above. To replicate this level of accuracy when in use, please follow the instructions for mounting and care of the stone carefully.

When mounting the stone for the first time it is important to ensure that it is seated correctly to ensure that it runs true.

Take care not to over tighten the lock nut as this may damage the stone and could cause excessive run out. The lock nut uses a left hand thread so does not need to be too tight as the thread is in the opposite direction of the rotation of the stone. Tighten the lock nut by hand until 'finger tight' and then using a 17 mm spanner, apply 1/8 turn to secure the stone.

Once the stone is secure, rotate it by hand and observe the run out. If it appears to be excessive, re-position the stone by loosening the lock nut and turning the stone on the shaft by ¼ turn, then tighten the lock nut again. Repeat this process until you are satisfied that the stone is seated in the position that offers the least run out.

The sharpening stone must be trued before first use with the **WG250/K** Diamond Trueing Tool and then dressed to the required finish with the **WG250/R** Stone Grader. Please refer to the relevant sections of this manual for details of how to use each of these accessories.

During use, all sharpening wheels will eventually run out of true. The sharpening of certain tools such as carving gouges and turning tools will cause hollow sections or grooves to appear in the surface of the stone very quickly. It is important to true and dress the surface regularly to maintain accuracy and prolong the working life of the stone. Use the 'little and often' technique: Truing the stone before each use will remove only a small amount of waste material from the surface of the stone, whereas repairing deep grooves will take longer and inevitably mean that more waste is removed, shortening the life of the stone.

Mounting the Honing Wheel

1. Install the honing wheel (A) on the friction drive wheel (O).
2. Lock in place using the lock knob (N).

The inner face of the honing wheel features three pins which locate in corresponding holes in the face of the drive wheel. To ensure that the honing wheel runs as true as possible, it is recommended to re-seat the wheel in one of the three possible locations. To do this, release the lock knob (N) and remove the honing wheel. Rotate the wheel 120° and re-fit it in the next set of locating holes. Lock the wheel in place using the lock knob (N). Repeat the process if necessary and select the location that offers the minimum run out of the honing wheel.

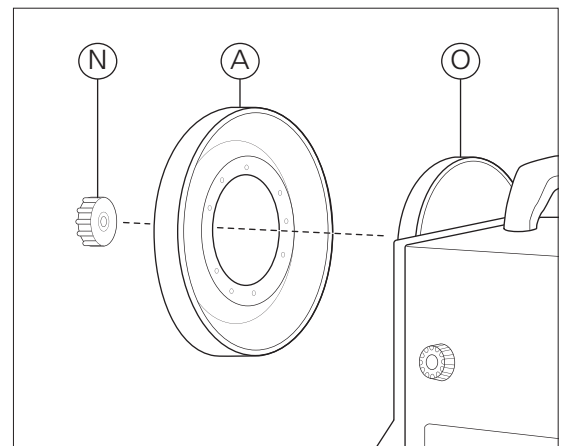

Note:

Before the first use of the leather honing wheel (A) condition with mineral oil (available as part of the **WG250/X** Maintenance Kit) and honing compound (R).

8. Assembly - Cont.

Mounting the Profiled Leather Honing Wheel

The **WG250/N** Profiled Leather Honing Wheel is an optional accessory.

1. Install the **WG250/N** Profiled Leather Honing Wheel on the shaft next to the leather honing wheel (A).
2. Place a washer on the shaft and tighten the lock knob (N).

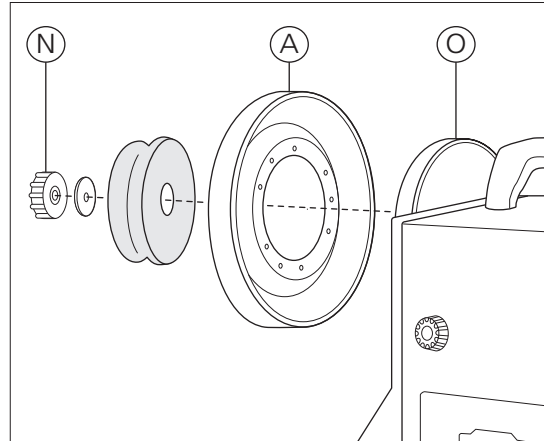

Mount the Water Tank

1. Install the water tank (F) on the side of the machine.
2. Fill the water tank with water up to the "MAX" marked water level.



Note:

The stone will soak up a lot of water (approximately 0.5 litre) in the first 15 minutes. When the stone wears down to a smaller diameter the second (upper) mounting position for the water tank has to be chosen.

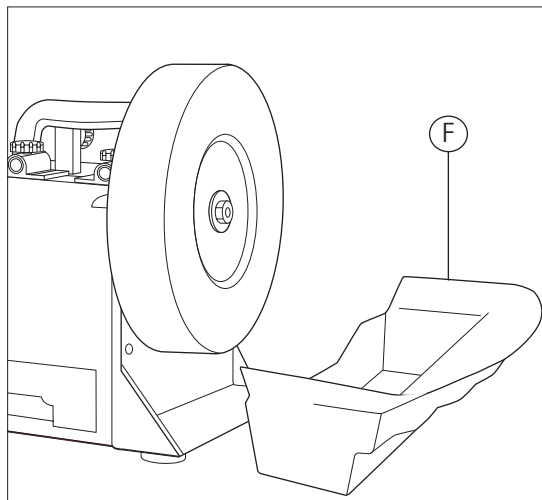

Mount the support arm

1. Install the support arm (G) to the machine.
2. Depending on the sharpening job the support arm can be installed in a vertical or horizontal position allowing you to grind towards or away from the edge.

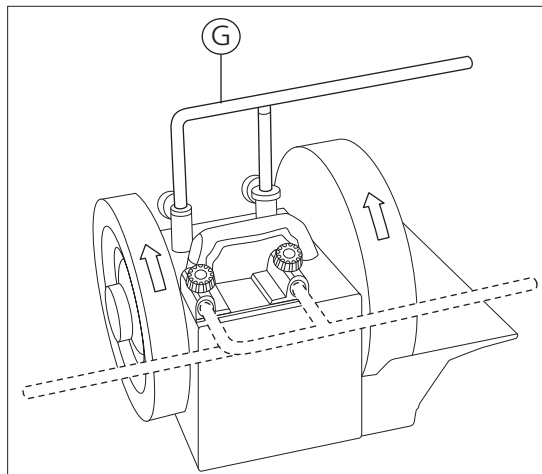

9. Set up and Adjustment

Starting Operation

- You can start and stop the machine with the ON/OFF switch (I).
- The machine has variable speed 90-150 min⁻¹ to adapt to various sharpening and honing applications.
- With the variable speed control knob (H) the best suitable speed can be chosen.
- As the diameter of the Sharpening Stone reduces during use the variable speed allows the user to compensate for it and select the optimum speed for the sharpening application.

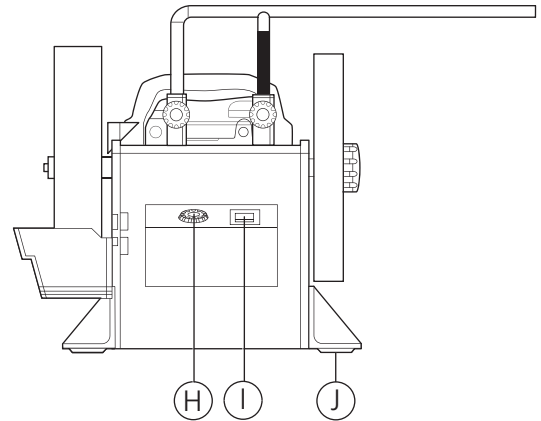

Machine Operation

- Always wear appropriate clothing and personal protection equipment.
- Use safety goggles at all times.
- Never place your hand near the machining area, grinding stone and honing wheel while machine is in operation.
- Flying sparks can occur when grinding dry. They can cause injury and ignite flammable materials.
- Remove defective abrasive wheels immediately.
- Tools are sharp and can lead to severe injuries, always handle them with care.
- Make certain the switch (I) is in the OFF-position before connecting the machine to the power supply.



Note: All operations described in this manual, including the truing and dressing of the sharpening stone, must be carried out with sufficient water in the trough to ensure the stone remains wet during use. This is to ensure no damage to the sharpening stone or items being sharpened occurs.

In the Event of a Blockage or if the Machine Stalls

If the machine stalls due to the work piece or other foreign body becoming trapped, switch the machine off immediately by pressing the red button on the switch marked 'O'.

Locate and rectify the source of the blockage. If the work piece has become trapped between the sharpening stone and the jig, the surface of the stone may become damaged. It may be necessary to dress or true the stone following the procedure set out in section 9 and 10.5 of this manual, before attempting to use the stone again.

Check that the sharpening stone can be turned freely by hand before attempting to re-start the machine. Re-start the machine by pressing the green button on the switch marked 'I'.

In the Event of a Power Failure

In the event of a power failure, first switch the machine off by pressing the red button marked 'O' on the switch.

Locate and rectify the source of the failure. If the fault is within the power circuit of the workshop, there may be an underlying cause (circuit overload etc.) that should be investigated by a qualified electrician, before attempting to restore the power source.

Once the power is restored, re-start the machine by pressing the button marked 'I' on the switch.

9. Set up and Adjustment - Cont.

Using the Diamond Trueing Tool

The **WG250/K** Diamond Trueing Tool is used to maintain the surface of the sharpening stone. In addition, it ensures that the sharpening surface remains both concentric to the shaft to which it is mounted and parallel to the support arm.

The diamond trueing tool consists of the following components:

- A. Trueing tool
- B. Diamond Tip
- C. Guide bar
- D. Locking Knob (x 2)

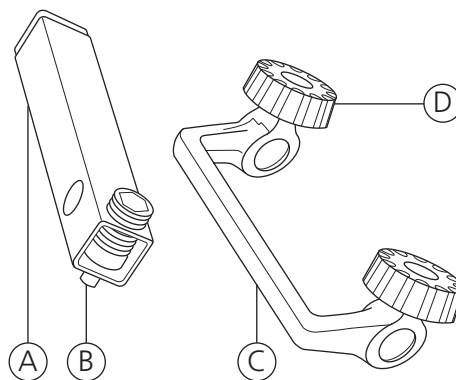

1. Mount the support arm in the upper position.
2. Slide one end of the guide bar on to the support arm, followed by the trueing tool, ensuring that the trueing tool is positioned below the guide bar.
3. Slide the remaining end of the guide bar on to the support arm, but do not secure with the locking knobs as adjustment is required before use.
4. Raise the rear end of the trueing tool so that it touches the underside of the guide bar and the diamond tip touches the surface of the sharpening stone, see figure 1. Secure the guide bar by tightening the two locking knobs.
5. Adjust the depth of cut by using the micro adjuster on the support arm to lower the trueing tool towards the sharpening stone. One quarter turn on the micro adjuster raise or lowers the support arm by approximately 0.4 mm. See figure 2.
6. Switch the machine on with the stone rotating towards the trueing tool.
7. Raise the rear end of the trueing tool so that it touches the underside of the guide bar and move the trueing tool from side to side across the stone (the guide bar remains fixed in position by the locking knobs). See figure 3. Work across the width of the stone taking approximately 45 seconds to cover the full width of the stone. Continue in this way until no further material is being removed from the stone.
8. If the surface of the stone is clear of any grooves or hollows, the process is complete. If the stone does need further work adjust the cutting height again using the micro adjuster and repeat the process.
9. The finished surface of the sharpening stone will be rough. Before use it will require dressing with the stone grader **WG250/R**.

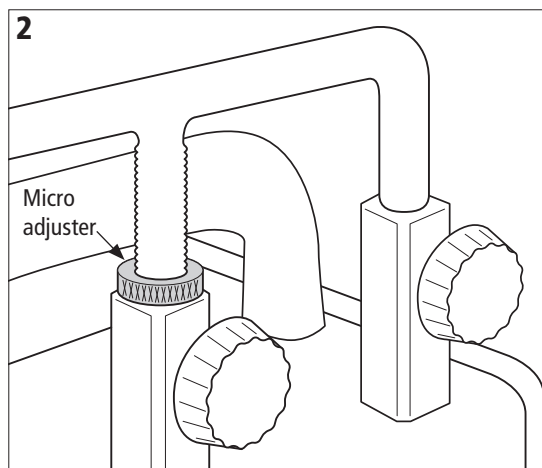
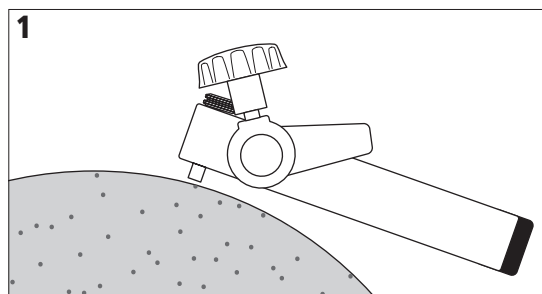

9. Set up and Adjustment - Cont.

The diamond tip will wear whilst in use. To avoid creating a flat area on the diamond tip, rotate it regularly using an allen key in the hex. socket on the end of the tip.

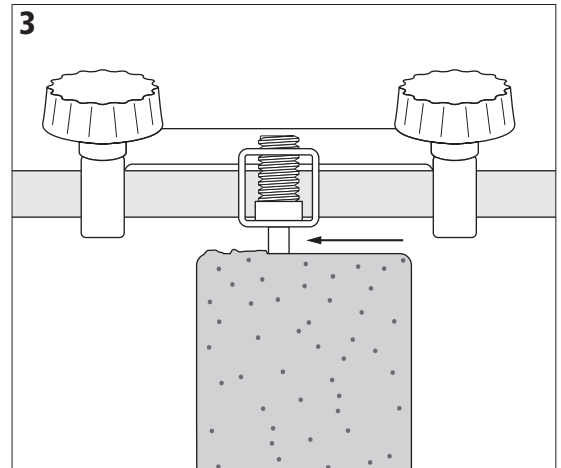

Sharpening Stone Dressing

The **WG250/R** Stone Grader is used for dressing the stone to suit different applications and for maintenance of the sharpening surface.

The coarse side of the stone grader changes the surface of the sharpening stone for normal or fast grinding. It can also be used to restore the surface of the stone as it becomes glazed. Glazing occurs naturally when grinding steel tools and noticeable reduction in the performance of the stone is a characteristic of glazing. Applying the coarse side of the stone grader to the sharpening stone will clean and restore the stone exposing a new sharpening surface.

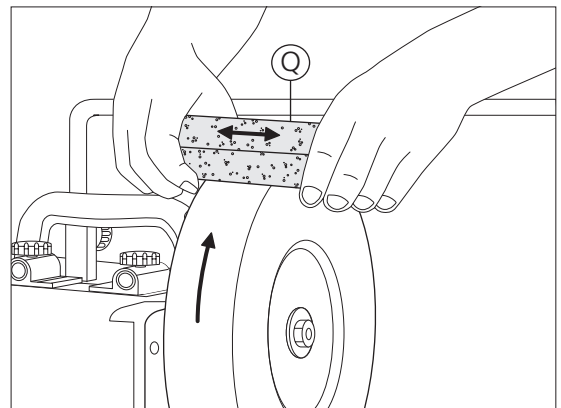

The smooth side of the stone grader changes the surface of the sharpening stone for fine sharpening.

A combination of both types of grinding is suited to most applications. Normal or fast grinding is ideal when forming the profile of the cutting edge and reduces machining time. Fine grinding can then be used for the final sharpening of the edge before honing.

To use the stone grader:

1. Start the machine.
2. Apply the required surface of the stone grader to the surface of the sharpening stone (Q). As relatively high pressure is needed for the stone grader to work effectively, it is recommended that it is applied to the sharpening

9. Set up and Adjustment - Cont.

stone at the top of its travel and with the sharpening stone rotating up towards the stone grader.

3. Apply pressure to the stone grader for approximately 30 seconds whilst moving from side to side across the sharpening stone.

The life of the stone grader depends entirely on the condition of the stone. Never apply the stone grader to a sharpening stone that has an uneven or worn surface. In this case always true the stone first with the diamond truing tool (WG250/K). When the surfaces of the stone grader become uneven it is at the end of its life and should be replaced.

Tool Grinding

- The tool to be sharpened must be held in the appropriate fixture and be guided firmly so it cannot move or fly off during the sharpening process.
- Never perform any operation freehand, where possible always use the appropriate jig. If no jig is available to suit the particular application, either use the tool rest jig (WG250/I) or use the support arm as a tool guide.
- In most cases you will achieve the best result if you grind towards the edge of the tool (as pictured).
- The wet sharpener may have to be turned around to get to a convenient operating position.
- Move the tool left/right as you grind for even wear of the stone.
- Narrow or convex cutting edges require little pressure only.

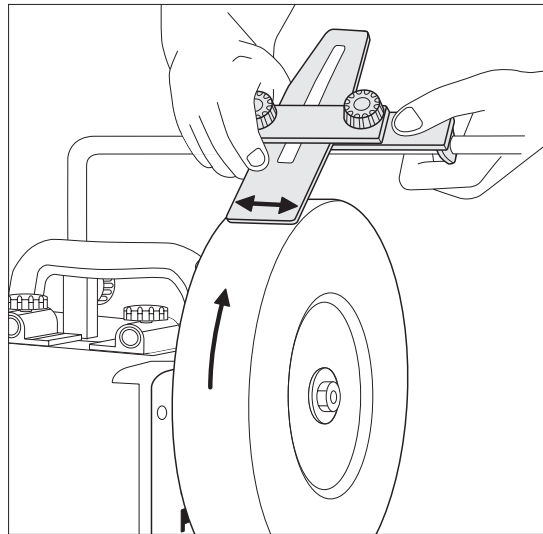

Tool Honing

- Apply honing compound (R) to the leather honing wheel (A).
- For a quick burr removal, alternately hone both sides of the cutting edge.
- Always hone away from the edge of the tool.
- The wet sharpener may have to be turned around to get to a convenient operating position.

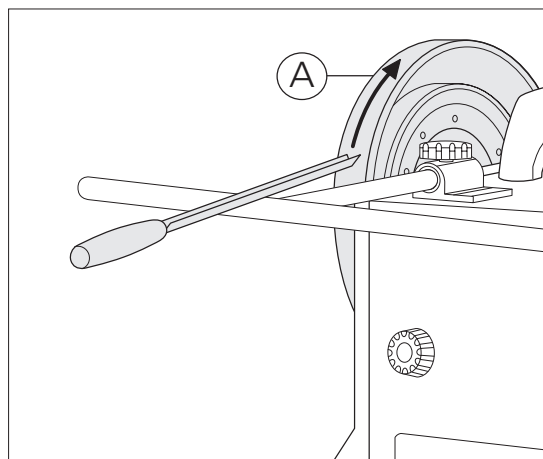

Attention: Never attempt to hone towards the edge of the tool as the tool will be thrown away and the honing wheel damaged.

9. Set up and Adjustment - Cont.



Attention: Make all adjustments or maintenance with the machine unplugged from the power source.

Sharpening Jig Setup

1. Use the angle finder (T) to establish the tools existing cutting edge.
2. Clamp the tool in the appropriate jig.
3. Adjust the support arm (G) and change the tool clamping position to get to the correct grinding angle.
4. Use the angle setting gauge (S) to inspect the angle in relation to the Sharpening Stone.

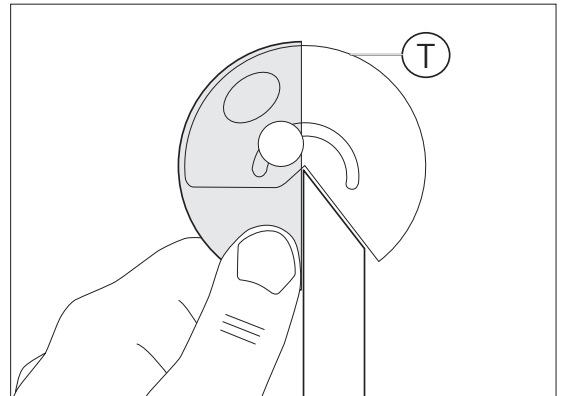

Note: The stone diameter needs to be set on the scale (X) to get correct angle reading.

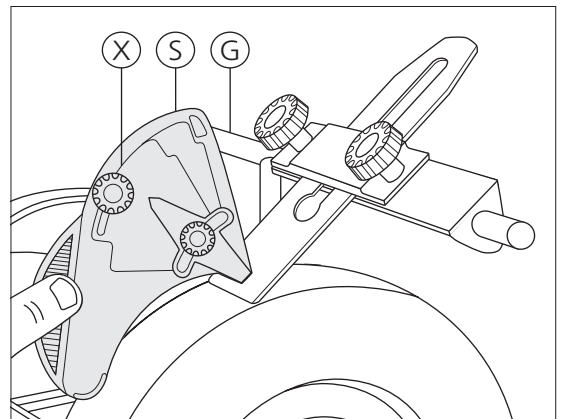

Torque Adjustment

- During heavy machining the friction drive may slip.
- Therefore a torque adjustment has been installed on the machine.
- Turn the torque adjusting knob (D) clockwise to add more pressure to the friction drive.
- When no added torque is required or when the machine is not in use, release the pressure to avoid permanent deformation of the friction drive rubber (O).

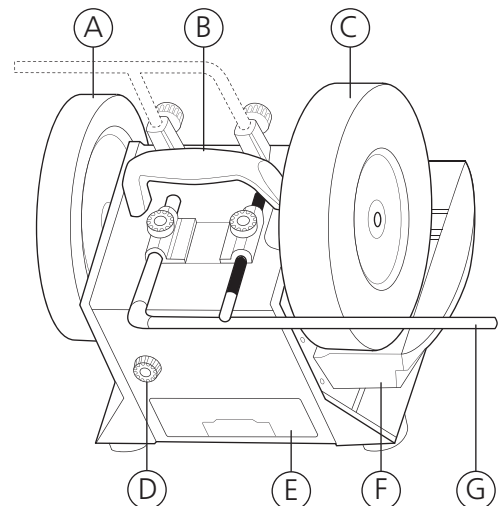

10. Optional Jigs for the WG250 Wet Stone Sharpener

To complement the WG250 Wet stone Sharpener Record Power offers an extensive range of jigs to allow the sharpening of a wide range of tools.



WG250/A Gouge Jig

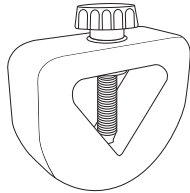

WG250/B Short Tool Jig

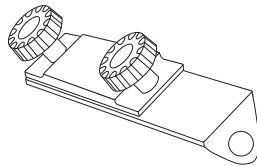

WG250/C Straight Edge Jig

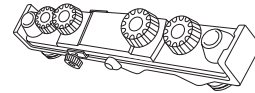

WG250/D Plane Camber Jig

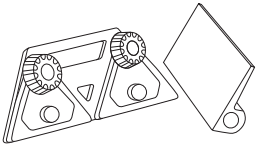

WG250/E Scissor Jig

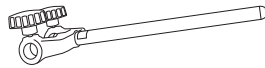

WG250/F Side Wheel Sharpening Jig

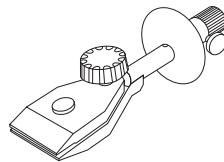

WG250/G Short Knife Jig

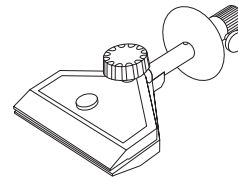

WG250/H Long Knife Jig

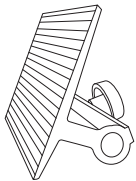

WG250/I Tool Rest Jig



WG250/J Axe Jig

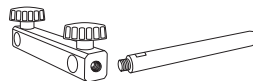

WG250/O Support Arm Extension Kit

For further information on the Record Power jig range or to purchase please contact your local retailer or visit the Record Power website.



Attention: Before using any wet stone sharpener or jig please refer to the Health & Safety Guidance and Additional Health & Safety for Wet stone Sharpeners in this manual.

10.1. WG250/G Short Knife Jig

Use to sharpen:

- Knives up to 4" in length
- Pocket knives
- Small cutlery knives

Getting to Know the Short Knife Jig

The adjustable clamp allows the jig to hold knives of any thickness.

- A. Adjustable Clamp
- B. Adjustable Stop
- C. Screw to adjust clamp to thickness of blade
- D. Knob to lock the knife in place
- E. Fine adjustment knob

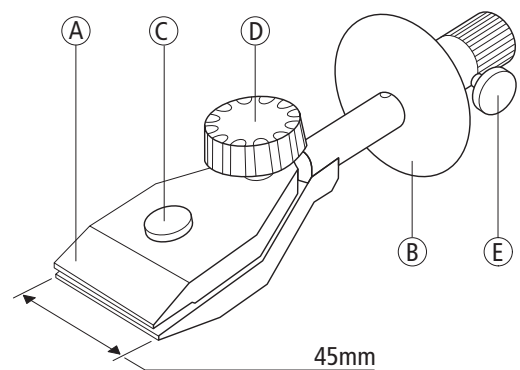

Using the Short Knife Jig

1. Loosen the large knob (D) on the centre of the clamp.
2. Place the knife in the clamp.
3. Use the screw (C) to adjust the clamp to the thickness of the knife.
4. Tighten the large knob (D) on the centre of the clamp to lock the knife in place.
5. The correct knife position when held in the clamp will keep the bevel and the edge angle consistent along the length of the blade.
6. Rest the Adjustable Stop (B) of your jig on the Sharpener's Support Arm.
7. The edge angle can be adjusted by turning the screw (E) on the side of the Adjustable Stop (B).
8. An inclusive angle of 25-30° range gives a uniform grind across the blade.
9. Ensure slow consistent movements over the grind stone.
10. Turn the jig holding the knife over to repeat process.

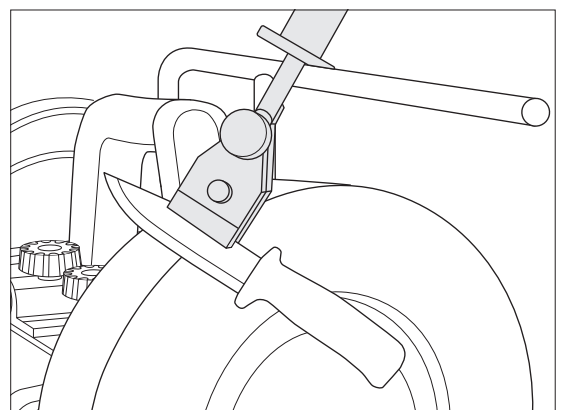
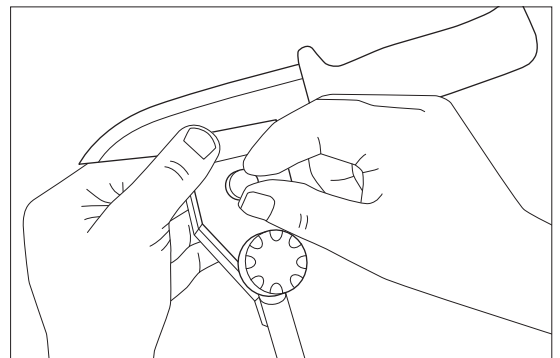

10.2. WG250/H Long Knife Jig

Use to sharpen:

- Knives over 4" in length
- Large knives
- Large cutlery knives
- Draw knives

Getting to Know the Long Knife Jig

The adjustable clamp allows the jig to hold knives of any thickness.

The long knife jig is wider than the Short Knife Jig so offers more support. The mounting and operation are the same as the Short Knife Jig above.

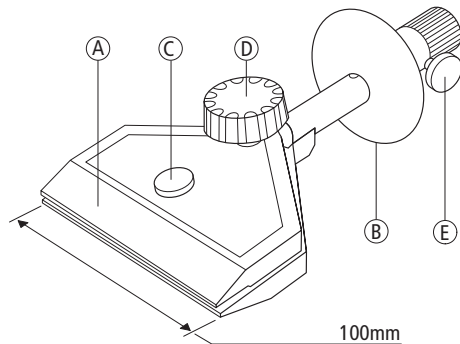

- A. Adjustable Clamp
- B. Adjustable Stop
- C. Screw to adjust clamp to thickness of blade
- D. Knob to lock the knife in place
- E. Fine adjustment knob

Using the Long Knife Jig

1. Loosen the large knob (D) on the centre of the clamp.
2. Place the knife in the clamp.
3. Use the screw (C) to adjust the clamp to the thickness of the knife.
4. Tighten the large knob (D) on the centre of the clamp to lock the knife in place.
5. The correct knife position when held in the clamp will keep the bevel and the edge angle consistent along the length of the blade.

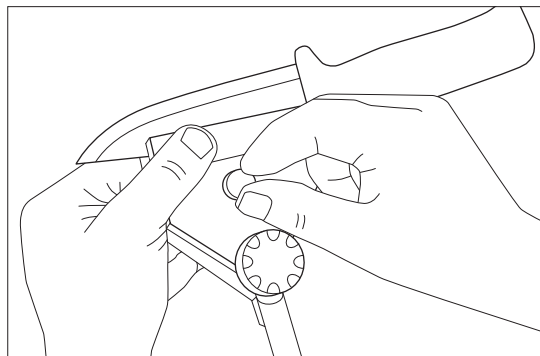

6. Rest the Adjustable Stop (B) of your jig on the Sharpener's Support Arm.
7. The edge angle can be adjusted by turning the screw (E) on the side of the Adjustable Stop (B).
8. An inclusive angle of 25-30° range gives a uniform grind across the blade.
9. Ensure slow consistent movements over the grind stone.
10. Turn the jig holding the knife over to repeat process.

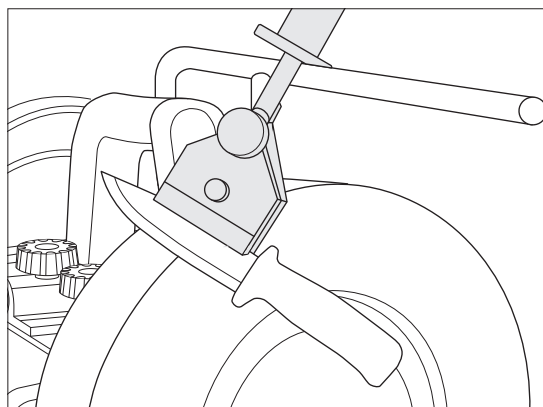

10.3 WG250/A Gouge Jig

Use to sharpen:

- Bowl gouges
- Spindle gouges
- V-tools

Getting to Know the Gouge Jig

The gouge jig attaches to the support arm of your wet stone sharpener.

- A. Knob screw
- B. Tool holder
- C. Shaft
- D. Support arm mount
- E. Elbow Joint

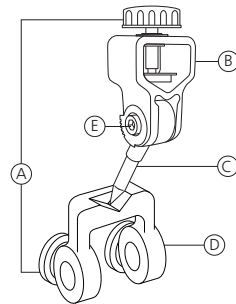

Using the Gouge Jig

1. Mount the tool in the tool holder with the required length of blade protruding to allow enough clearance between the jig and stone when in use. The protrusion varies depending on the tool being sharpened and a good rule of thumb is at least 50 mm (2") is sufficient for many tools. See **Fig 1**.
2. Adjust the angle of the shaft (C) relative to the tool holder (B) using the allen screw located inside the elbow joint (E). For shorter side bevels, such as those found on bowl gouges, lock the shaft in the uppermost position and for longer bevels, as on spindle gouges, lock the shaft in lower positions. See **Fig 2**.

Please note this should be done before setting the position of the tool to the correct nose angle as any adjustments of the shaft after this will change the nose angle sharpening.

3. Secure the support arm mount (D) to the support arm in a vertical position and with it aligned centrally to the cutting face of the sharpening wheel. See **Fig 3**.
4. With the tool secured in the tool holder (B), place the shaft (E) in the recess of the support arm mount. The support arm must then be moved to a position which allows the tool to be applied to the sharpening wheel at the correct angle, meaning that as much of the edge of the tool should come into contact with the stone as possible. See **Fig 4**.
5. To sharpen the tool, locate the shaft (E) in the recess of the support arm mount and carefully apply the tool to the wheel, see **Fig 5**, ensuring contact is kept whilst pivoting the shaft to sharpen all the way round the edge. See **Fig 6**.

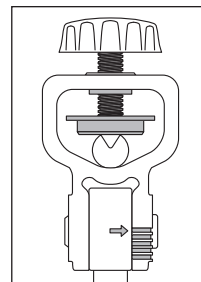

Fig 1

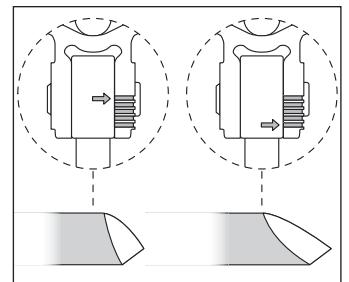

Fig 2

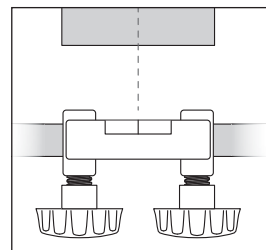

Fig 3

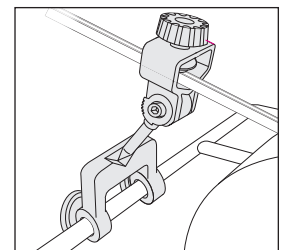

Fig 4

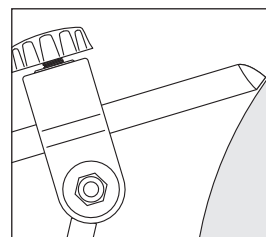

Fig 5

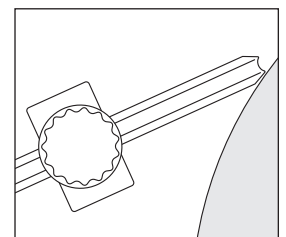

Fig 6

10.4. WG250/B Short Tool Jig

Use to sharpen:

- Small carving tools
- Small gouges
- V-tools

Getting to Know the Short Tool Jig

The Short Tool Jig rests on to the support arm of your wet stone sharpener.

- A. Knob screw
- B. Tool holder

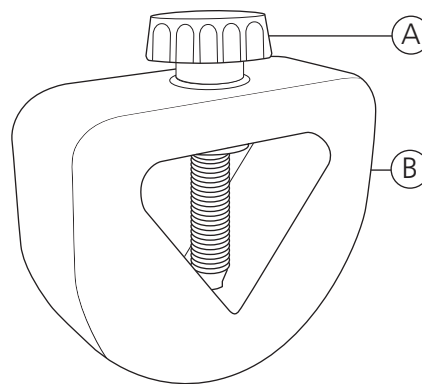

Using the Short Tool Jig

1. Slide your tool in to the tool holder (B) and lock in place with knob screw (A).
2. The support arm position can be adjusted to alter the grind angle.
3. Hold carving jig against support arm in lower position.
4. For most carving tools and other thin edge tools it is advisable to grind away from the edge of the tool for increased control.
5. With the Sharpening Stone in motion move the tool slowly from side to side.
6. To finish hone your tool on the leather honing wheel, see page 11.

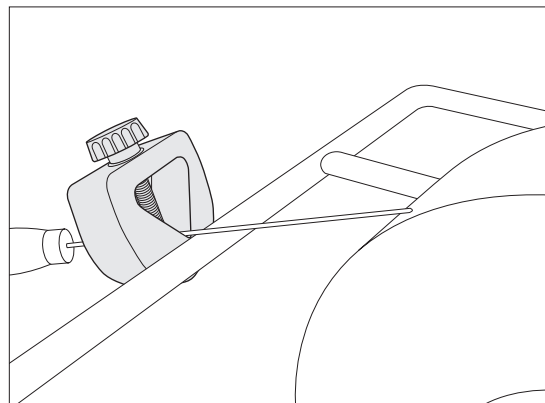

10.5. WG250/E Scissor Jig

Use to sharpen:

- Scissors
- Garden shears

Getting to Know the Scissor Jig

The scissor jig mounts on to the support arm of your wet stone sharpener.

- A. Knob screw
- B. Scissor holder
- C. Clamp
- D. Support plate

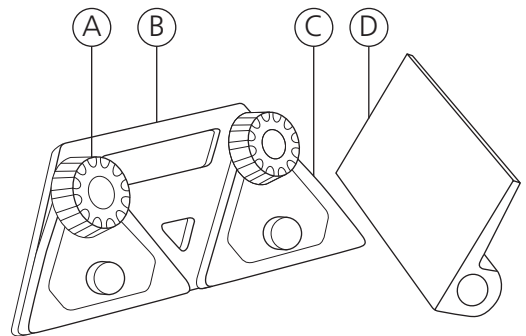

Using the Scissor Jig

1. Mount support arm in upper position.
2. Slide support plate (D) on to support arm.
3. Open your scissors and clamp (C) in the holder (B) with blade facing out.
4. With Sharpening Stone in motion slide the scissors clamped in the holder across the support plate (D).
5. Reverse the scissors in the holder (B) and repeat.

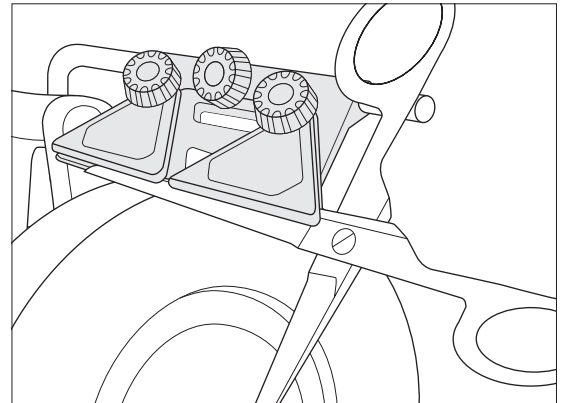

Note:

Usually you use only the right clamp. For large scissors and garden shears you use both clamps.

10.6. WG250/D Plane Camber Jig

Use to sharpen:

- Camber planer blades up to 3" wide

Getting to Know the Plane Camber Jig

The plane camber jig slides on the support arm of your wet stone sharpener.

- A. Lock nut
- B. Fence
- C. Lock knob
- D. Rocker pads

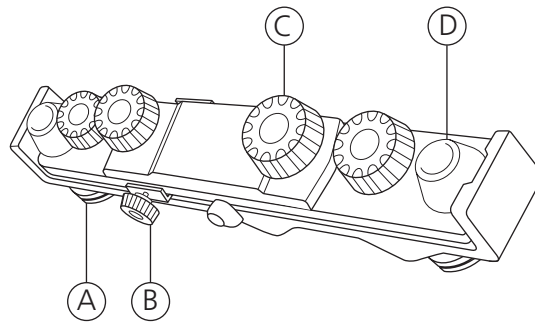

Using the Plane Camber Jig

1. Mount the support arm in upper position.
2. Centre your plane in the middle of your jig. Use the fence to gain a straight edge. Lock the blade in place using the lock knobs.
3. At either end of the jig there are two rocker pads. These pads are used to apply pressure to the blade to achieve a camber. The amount of pressure can be changed by adjusting the lock nuts on the reverse of the rocker pads.
4. When grinding you can apply pressure, from left to right in the direction you move the jig along the support arm.
5. To finish hone your plane blade on the leather honing wheel, see page 11.

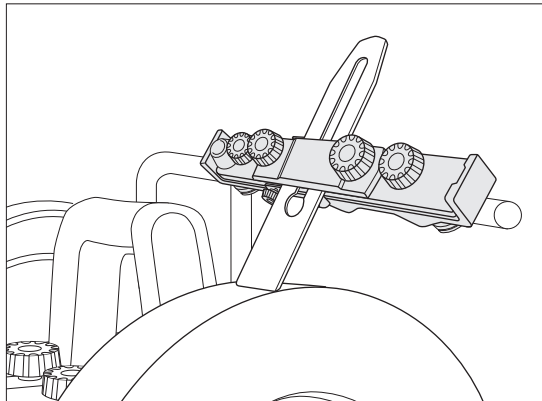

Note:

A plane blade is best sharpened to a convex shape which allows you to make a cut without leaving edge marks or lines. The best way to achieve this is to add camber to your blade.

10.7. **WG250/J** Axe Jig

Use to sharpen:

- Carving axes
- Carpenter's axes

Getting to Know the Axe Jig

The axe jig slides on the support arm of your wet stone sharpener.

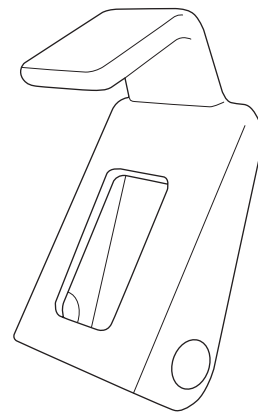

Using the Axe Jig

1. Mount the support arm in the upper position.
2. Slide the axe jig on to the support arm.
3. Cup the head of the axe in the jig and move the axe blade slowly back and forth across the Sharpening Stone when in motion.
4. Reverse the axe in the jig and repeat.

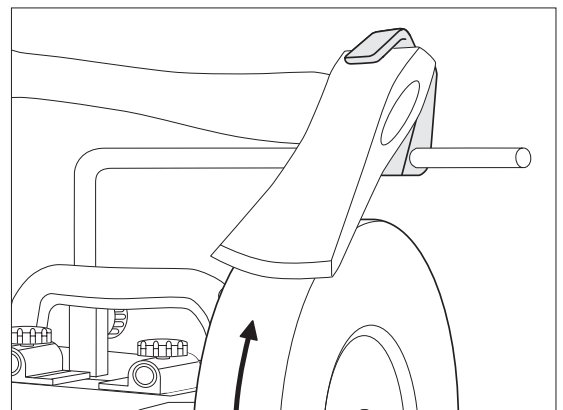

10.8. WG250/C Straight Edge Jig

Use to sharpen:

- Plane irons
- Bevel edge chisels

Getting to Know the Straight Edge Jig

The straight edge jig slides on to the support arm of your wet stone sharpener.

The straight edge jig aligns the tool automatically to its upper and flat side.

- A. Clamp
B. Lock knob

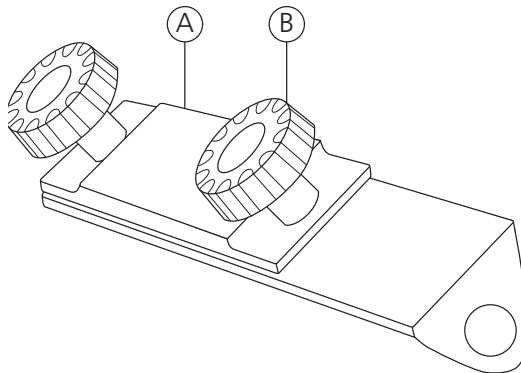

Using the Straight Edge Jig

1. Mount the support arm in the upper position.
2. Slide your tool to the edge of the clamp and lock in place with the lock knobs.
3. Do not over tighten central lock knob as this will cause the tool to twist in clamp.
4. Slide the straight edge jig on to the support arm.
5. To set the angle use the angle setting gauge and adjust by raising or lowering the support arm.
6. Move the tool slowly back and forth across the Sharpening Stone when in motion.
7. To finish hone your blade on the leather honing wheel, see page 11.

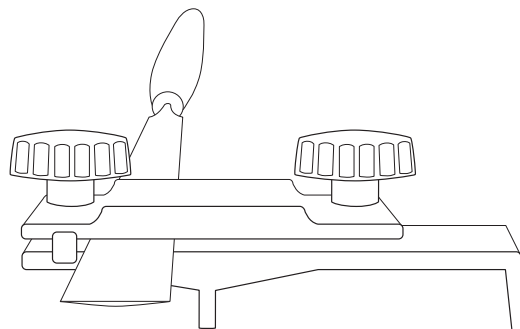
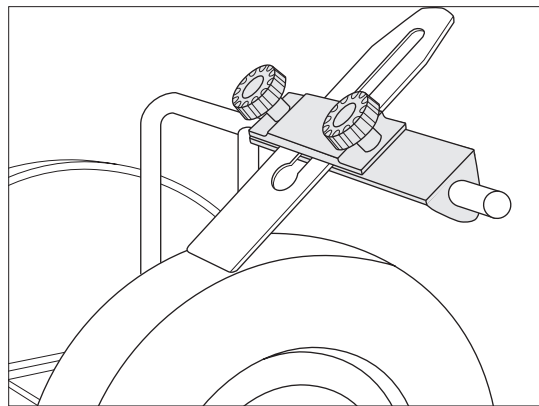

10.9. WG250/I Tool Rest Jig

Use to sharpen:

- Scrapers
- Screw drivers
- Cabinet scrapers
- Hollowing tools
- Spoke shave blades

Getting to Know the Tool Rest Jig

The tool rest jig mounts on to the support arm of your wet stone sharpener.

A. Lock knob

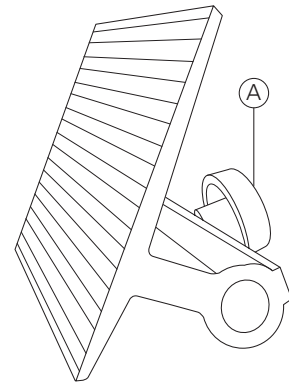

Using the Tool Rest Jig

1. Mount the support arm in either the lower or upper (pictured) position.
2. Slide the tool rest jig on to the support arm and fix in place with the lock knob.
3. Different angles can be achieved by raising or lowering the support arm.
4. Rest your tool on the jig and move the blade slowly back and forth across the Sharpening Stone when in motion.
5. To finish hone your blade on the leather honing wheel, see page 11.
6. The tool rest jig can be mounted on the support arm with either the short or long edge facing the stone to achieve different angles.

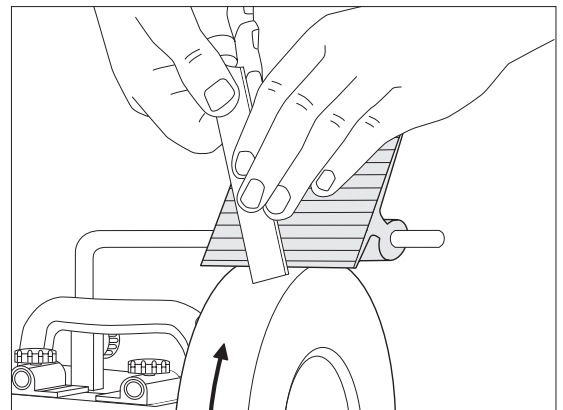

10.10. **WG250/F** Side Wheel Sharpening Jig

Use to sharpen:

- Scrapers

Getting to Know the Side Jig

The side jig mounts on to the support arm of your wet stone sharpener and allows you to grind against the side of the Sharpening Stone.

- A. Lock knob
- B. Support arm

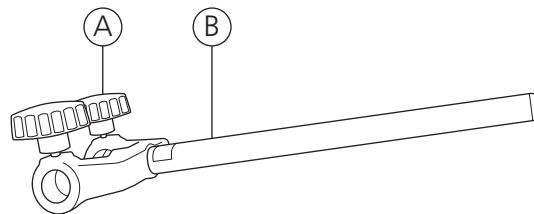

Using the Side Jig

1. Slide the side jig on to the support arm and fix in place with the lock knobs.
2. The side jig is used in conjunction with the tool rest jig to enable the user to grind against the side of the wheel.
3. Different tools can be sharpened and angles achieved by raising and lowering the support arm and changing the position of the side jig on the support arm.

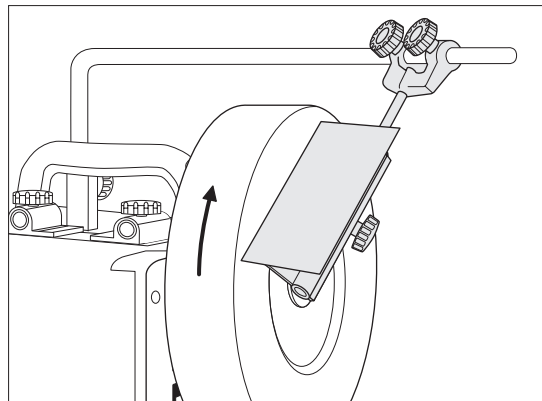

10.11. **WG250/O** Support Arm Extension Kit

Getting to know your extension arm

The extension arm mounts on the support arm (G). The extension arm will allow the user to grind and then hone without having to reposition the support arm and reset the angle. The extension arm allows the user better access to the leather honing wheel and the optional secondary strop.

- A. Lock knob
- B. Extension arm

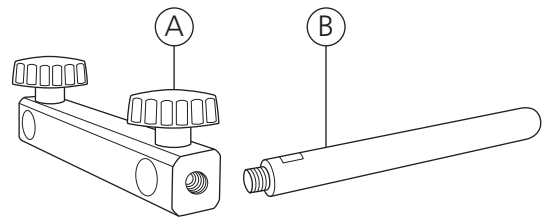

Mounting your extension arm

1. Mount the support arm in the lower position.
2. Slide the extension arm on to the support arm and fix in place with the lock knobs.



Attention: Never attempt to hone towards the edge of the tool. The tool will be thrown away and the honing wheel damaged.

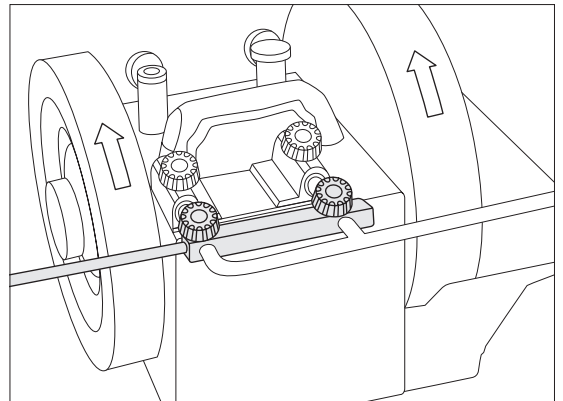

11. Maintenance

- Make all adjustments or machine maintenance with the machine unplugged from the power source.
- Repair and maintenance work on the electrical system may only be carried out by a qualified electrician.
- All protective and safety devices must be re-attached immediately after completed cleaning, repair and maintenance work.
- Defective safety devices must be replaced immediately.

Cleaning

- Regularly change the water in the water tank.
- Regularly clean the machine housing with a soft cloth preferably after each use.
- If the dirt does not come off use a soft cloth moistened with soapy water.
- Never use solvents such as petrol, alcohol, ammonia water, etc.
- These solvents may damage the plastic parts.
- To protect your sharpener from dust and damage when not in use, an optional heavy duty cloth cover, WG250/Q is available. Please contact your local retailer or visit the Record Power website for further details.

Storage

- The machine has an integrated storage drawer
- The angle finder (T) will stick to the magnets on the designated place at the side of the machine.
- The angle setting gauge (S) has integrated magnets and will stick to the machine body at any place.

Inspecting the brushes

- Disconnect from power source, unplug!
- Inspect the motor brushes after 300 hours of use.
- If the brushes are worn to 6 mm replace them. Always replace the brushes in pairs.

11. Maintenance - Cont.

Changing the Sharpening Stone

If the sharpening stone (C) is worn down to a diameter of approximately 150mm it needs to be replaced.

1. Disconnect the WG250 from the power source.
2. Loosen the Nut (M) and remove the old sharpening Stone.



Note:

That the lock nut (M) has a left hand thread i.e. turn clockwise to loosen, turn anti-clockwise to tighten.

3. The new Sharpening Stone has to meet the correct technical specification. Always use a genuine replacement stone.
4. Check abrasive wheel for flaws (e.g. cracks) before installation. Do not use faulty wheels.
5. Install the new Sharpening Stone (C).
6. Place a washer (L) on each sides of the sharpening stone and tighten the nut (M).

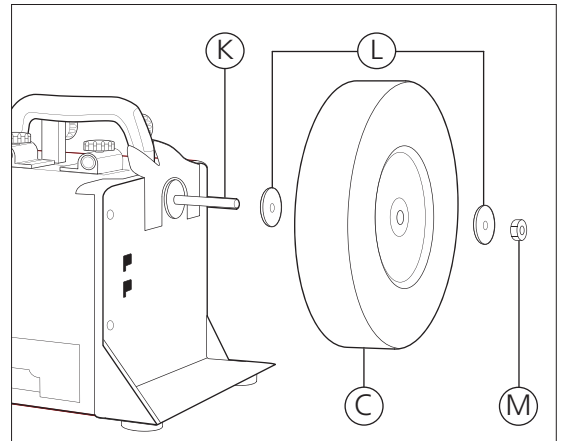

Changing the honing wheel

1. Disconnect the WG250 from the power source.
2. Loosen the lock knob (N) and remove the worn honing wheel.
3. Install the new leather honing wheel (A)
4. Pay attention that the 3 drive pins engage with the friction drive wheel (O).
5. If the leather strop wheel seems to wobble, please try rotating it to the next pin location.
6. Tighten the lock knob (N)

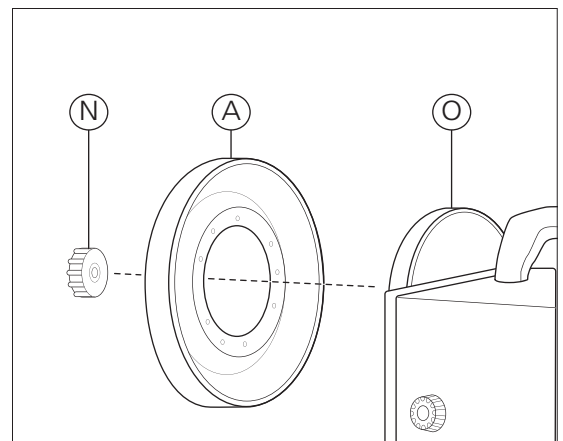

12. Troubleshooting

Problem	Possible cause	Suggested corrective action
Motor does not start	<ol style="list-style-type: none"> 1. Power cable defect 2. Connections on the motor or switch defect 3. Carbon brushes worn 4. No electricity 	<ol style="list-style-type: none"> 1. Change proper power cable 2. Have to be checked by an electrician 3. Replace the carbon brushes 4. Check main power and fuse
Machine vibrates excessively	<ol style="list-style-type: none"> 1. Stand on uneven surface 2. Abrasive wheel unbalanced 	<ol style="list-style-type: none"> 1. Adjust base for even support 2. Use diamond trueing tool to improve run-out
Sharpening surface not flat	<ol style="list-style-type: none"> 1. Worn Sharpening Stone grit 2. Static grinding 	<ol style="list-style-type: none"> 1. Use stone grader or diamond trueing tool to straighten the wheel surface 2. Move the tool as you grind for even wear of the stone
Sharpening surface is bad	<ol style="list-style-type: none"> 1. Worn stone 2. Leather honing wheel is dry 3. Pressure too high 	<ol style="list-style-type: none"> 1. Use stone grader to sharpen the grit 2. Add honing compound to the wheel 3. Do not force the tool
Brush sparks when switch release	<ol style="list-style-type: none"> 1. Carbon brushes worn 2. Surface of commutators not clean 	<ol style="list-style-type: none"> 1. Replace the carbon brushes 2. Clean of foreign matters and make the surface smooth

13. Electrical Connection & Wiring Diagram

Machines supplied for use in the UK are fitted with a 3 pin plug conforming to BS1363, fitted with a fuse conforming to BS1362 and appropriate to the current rating of the machine.

Machines supplied for use in other countries within the European Union are fitted with a 2 pin Schuko plug conforming to CEE 7/7.

Machines supplied for use in Australia & New Zealand are fitted with a 3 pin plug conforming to AS/NZS3112.

In all cases, if the original plug or connector has to be replaced for any reason, the wires within the mains power cable are colour coded as follows:

230 V (Single Phase)

Brown: Live (L)
Blue: Neutral (N)
Green and Yellow: Earth (E)

The wire coloured brown must always be connected to the terminal marked 'L' or coloured red.

The wire coloured blue must always be connected to the terminal marked 'N' or coloured black.

The wire coloured green and yellow must always be connected to the terminal marked 'E' or with the earth symbol:



or coloured green / green and yellow.

It is important that the machine is effectively earthed. Some machines will be clearly marked with the double insulated logo:



In this case there will not be an earth wire within the circuit.

In the case of the BS1363 plug for use in the UK, always ensure that it is fitted with a fuse conforming to BS1362 appropriate to the rating of the machine. If replacing the original fuse, always fit a fuse of equivalent rating to the original. Never fit a fuse of a higher rating than the original. Never modify the fuse or fuse holder to accept fuses of a different type or size.

Where the current rating of the machine exceeds 13 A at 230 V, or if the machine is designated for use on a 400 V 3 phase supply a connector conforming to BS4343 (CEE17 / IEC60309) will be used.

230 V machines will be fitted with a blue 3 pin connector.

The wiring for this type of this connector will be the same as shown above.

400 V, 3 phase machines will be fitted with a red 4 or 5 pin connector. The wiring for this type of connector is as shown below:

400 V (3 phase)

Brown: Live (L1)
Black: Live (L2)
Grey: Live (L3)
Blue: Neutral (N)
Green and Yellow: Earth (E)

The wire coloured brown must always be connected to the terminal marked 'L1'.

The wire coloured black must always be fitted to the terminal marked 'L2'.

The wire coloured grey must always be connected to the terminal marked 'L3'.

The wire coloured blue must always be connected to the terminal marked 'N' or coloured black.

The wire coloured green and yellow must always be connected to the terminal marked 'E' or with the earth symbol. If in doubt about the connection of the electrical supply, always consult a qualified electrician.

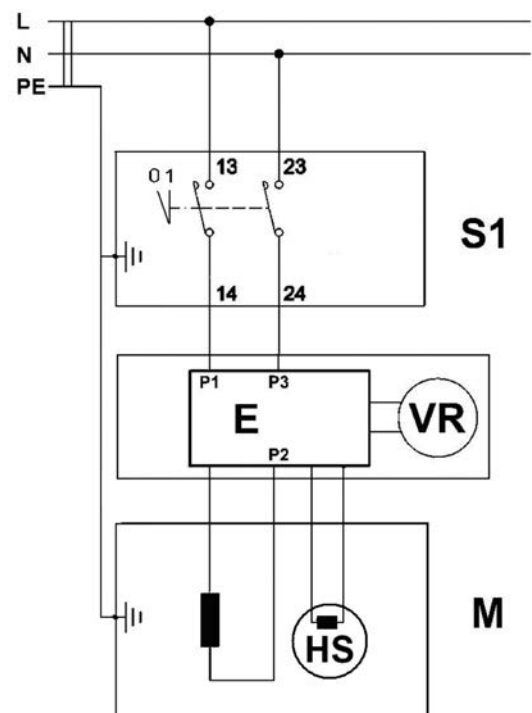

14. Parts Lists & Diagrams

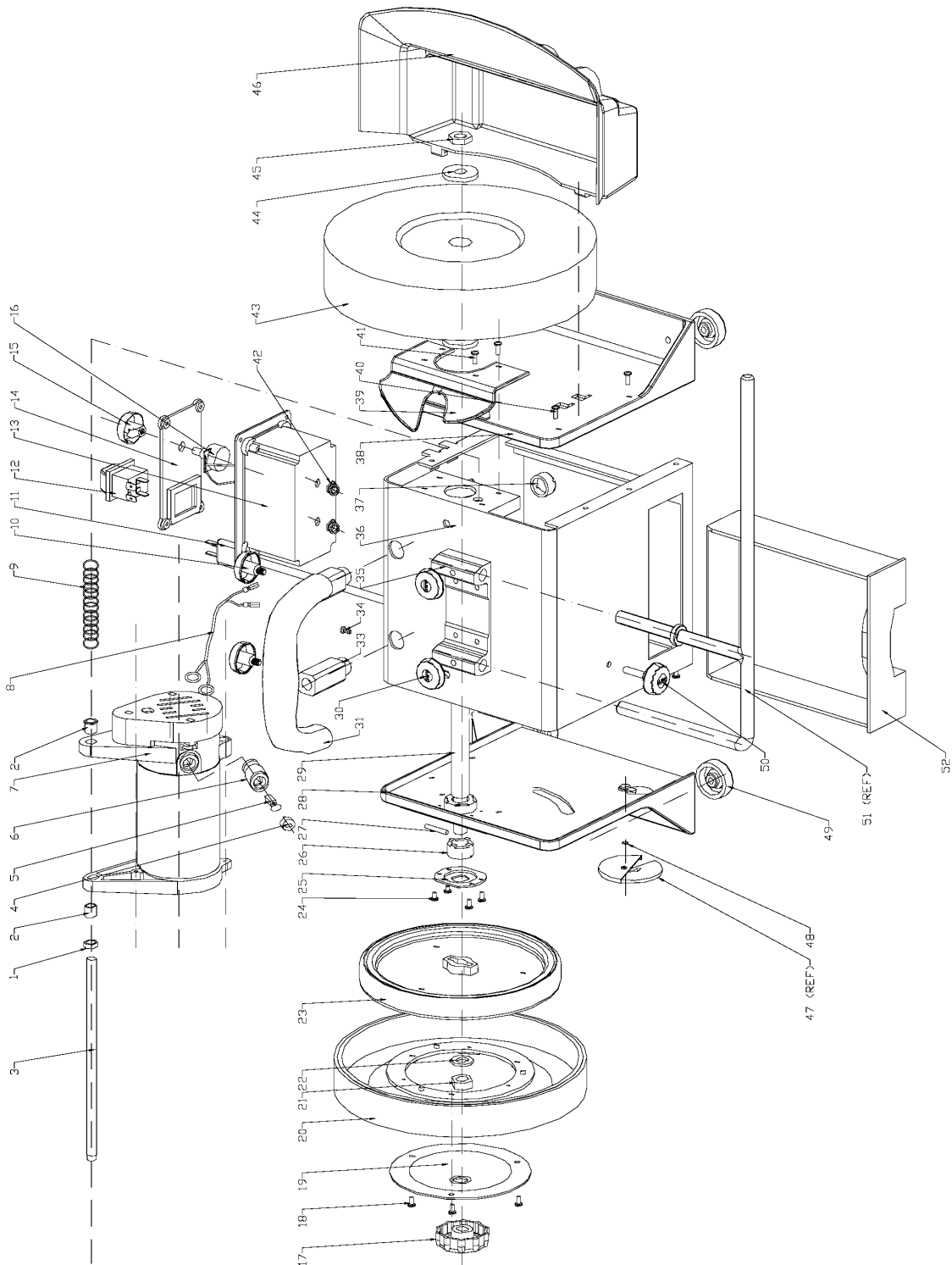

14. Parts Lists & Diagrams - Cont.

Number	Part Name	Quantity
001	Spacer	1
002	Bushing	2
003	Motor Mount Shaft	1
004	Carbon Brush Cover	2
005	Carbon Brush	2
006	Carbon Brush Holder	2
007	Motor (Complete) 230V, 50Hz	1
008	Motor Wire	1
009	Pressure Spring	1
010	Knob with M6 Bolt Insert	2
011	Power Cord with Plug	1
012	On/Off Switch	1
013	Switch Box	1
014	Switch Box Cover	1
015	Speed Switch Knob with indicator	1
016	Slide Bearing	1
017	Honing Wheel Lock Knob	1
018	Self-Tapping Screw ST4x6	3
019	Honing Wheel End Cover	1
020	Honing Wheel with Leather	1
021	Lock Nut	1
022	Flat Washer M12	2
023	Drive Wheel	1
024	Self-Tapping Screw ST3x4	8
025	Slide Bearing Cover	2
026	Slide bearing	2

Number	Part Name	Quantity
027	Pin	1
028	Left Machine Support	1
029	Drive Shaft	1
030	Handle	2
031	Horizontal Support Knob	1
033	Vertical Support	1
034	Ground Screw	2
035	Horizontal Support	1
036	Machine Body	1
037	Vertical Support Lock Nut	1
038	Right Machine Support	2
039	Water Shield	1
040	Pan Head Machine Screw M5x6	1
041	Pan Head Machine Screw M5x10	17
042	Cord Strain Relief	13
043	Wheel	4
044	Washer OD Ø 30mm	1
045	Hex Nut M12	2
046	Water Tank	1
047	Chisel Angle Jig	1
048	Cylinder Magnet	1
049	Rubber Foot	1
050	Torque Adjusting Knob	4
051	Support Arm Assembly	1
052	Drawer	1
Not shown:	Socket head cap screw M8x25 (For handle)	2
	Nylon Insert Lock nut M8 (For handle)	2
	Flat Washer M8 (For handle)	2

EU Declaration of Conformity

Cert No: EU / WG250 / 1

RECORD POWER LIMITED,
Unit B, Ireland Industrial Est.
Adelphi Way, Staveley, Chesterfield S43 3LS
declares that the machinery described:-

- 1. Type: **Wet Stone Sharpener**
- 2. Model No: **WG250**
- 3. Serial No

Conforms with the following directives:-

Machinery Directive: 2006/42/EC
EN61029-1:2009+A11:2010

Low Voltage Directive: 2006/95/EC
EN55014-1:2006+A1:2009
EN55014-2:1997+A1:2001+A2:2008
EN61000-3-2:2006+A1:2009+A2:2009
EN61000-3-3:2008

Electromagnetic Compatibility: 2004/108/EC

Certificate Numbers: AW501744940001

Issued by: TÜV Rheinland LGA Products GmbH, Tillystrasse 2 - 90431 Nürnberg



A handwritten signature in black ink, appearing to read 'Andrew Greensted', is written over a dotted line.

Signed..... Dated: 01/11/2012

Andrew Greensted
Managing Director



Over
100
 years
 Experience • Knowledge
 Support • Expertise

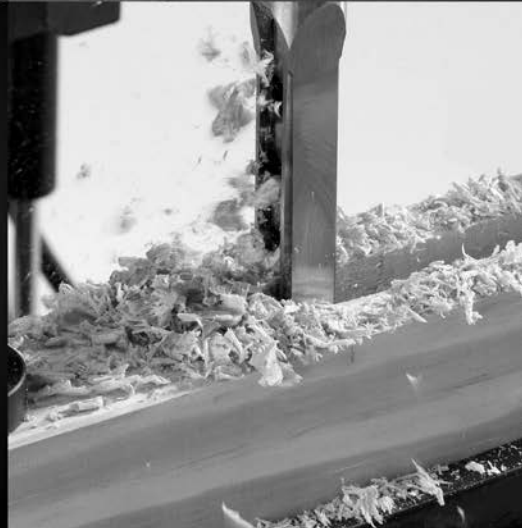

RECORD POWER
 ESTABLISHED 1909®

Woodworking Machinery & Accessories

United Kingdom

Record Power Ltd
 Unit B Adelphi Way, Ireland
 Industrial Estate, Staveley,
 Chesterfield, Derbyshire S43 3LS
 Tel: 01246 561 520
www.recordpower.co.uk

Eire

Record Power Ltd
 Unit B Adelphi Way, Ireland
 Industrial Estate, Staveley,
 Chesterfield, Derbyshire S43 3LS
 Tel: 01246 561 520
www.recordpower.co.uk

Australia

Tools 4 Industry
 Po Box 3844
 Parramatta 2124
 Tel: 1300 124 422
 Fax: 1800 262 725
www.recordpower.com.au

New Zealand

Tools 4 Industry
 Po Box 276079
 Manukau City 2241
 Tel: 0800 142 326
 Fax: 09 2717 237
www.recordpower.co.nz