

RELIABILITY *for real life*[®]

OAKFOLD FRENCH PATIO DOORSET FITTING & FIXING GUIDELINES



CAUTION SAFETY: Large windows and glass units are heavy and may be hazardous. Great care **MUST** be taken to avoid injury during manual handling and particular precautions are required when working at height. The following instructions and recommendations should be followed. Failure to do so may affect the guarantee and the long term performance of the window and glazing.



SELECTION |

Building Regulations

Please consult with your building designer to ensure compliance with current Building Regulations such as Approved Documents L&F.

Replacing patio doorsets is included under Building control and MUST either be carried out by a FENSA or other registered installer, or with prior Building Control Approval.

Registered FENSA companies can be found at www.fensa.co.uk

Read before installation

A timber doorset must not be exposed to extremes of temperature or humidity prior to decoration.

It must be kept dry and stored flat in a protected, well-ventilated area. Polythene or other protective wrappings should remain on the door as long as possible.

If stacking, use a minimum of three bearers, equally spaced along the length and across the full width of the doorset, to ensure an equal distribution of weight.

Preparation for and installation of any additional hardware must be effected in a manner that ensures that water cannot penetrate inside the external protective coating/layer.

All joinery shall be installed correctly in accordance with normal trade practices and adequately maintained in service.

Tools required

The following tools and items are required to carry out the installation of the doorset:

- Appropriately long spirit level
- Drill
- Cordless screw driver
- 5 metre measuring tape
- Appropriate Timber Silicone Sealant (appx. 3 tubes)
- Mallet
- Additional packers for accurate frame installation (frame to structure) if required
- Drill bit - 3.0mm diameter timber, 80mm minimum length

Product sizes:

| Frame Size mm | Brickwork Opening mm |
|---------------|----------------------|
| 1190 x 2090 | 1200 x 2100 |
| 1490 x 2090 | 1500 x 2100 |
| 1790 x 2090 | 1800 x 2100 |

Your new French doors and frame are designed to be installed with the minimum of effort..

IMPORTANT

Storage: All doors should be stored, protected and fitted to the British Standard code of practice C.P.151 Part 1, 1965 (Wooden Doors).

Unfinished products must be decorated immediately after delivery and prior to installation.

On receiving the doors, frame and hardware pack, check the contents against the pack contents.

Pack contents

The hardware per door set is as follows:

| | | |
|--------|-----|------------------------------|
| 2 off | (A) | Titon Vents |
| 4 off | (B) | Grills |
| 1 off | (C) | Espagnolette |
| 1 off | (D) | Aluminium Threshold |
| 6 off | (F) | Butt Hinges |
| 2 off | (G) | Shootbolts (Slave Doors) |
| 1 off | (I) | Pair Handles |
| 1 off | (J) | Universal Timber Centre Keep |
| 4 off | (K) | Timber Keep (Hook) |
| 1 off | (L) | Cylinder Lock |
| 2 off | | Rain deflectors |
| 10 off | | Fixing ties |
| 1 off | (M) | Cover Spline |
| 2 off | (N) | Spline end caps & screws |

Screws:

| | | |
|--------|----------|---------------------|
| 4 off | 4.0 x 40 | Threshold |
| 24 off | 5.0 x 90 | Frame |
| 24 off | 4.0 x 40 | Hinges |
| 8 off | 5.0 x 60 | Sidelight |
| 11 off | 4.0 x 40 | Keeps |
| 12 off | 4.0 x 40 | Lock |
| 4 off | 4.0 x 40 | Shoot bolts |
| 4 off | 4.0 x 40 | Vents |
| 8 off | | Brickwork with caps |
| 12 off | 4.0 x 40 | Head/Sill plant |

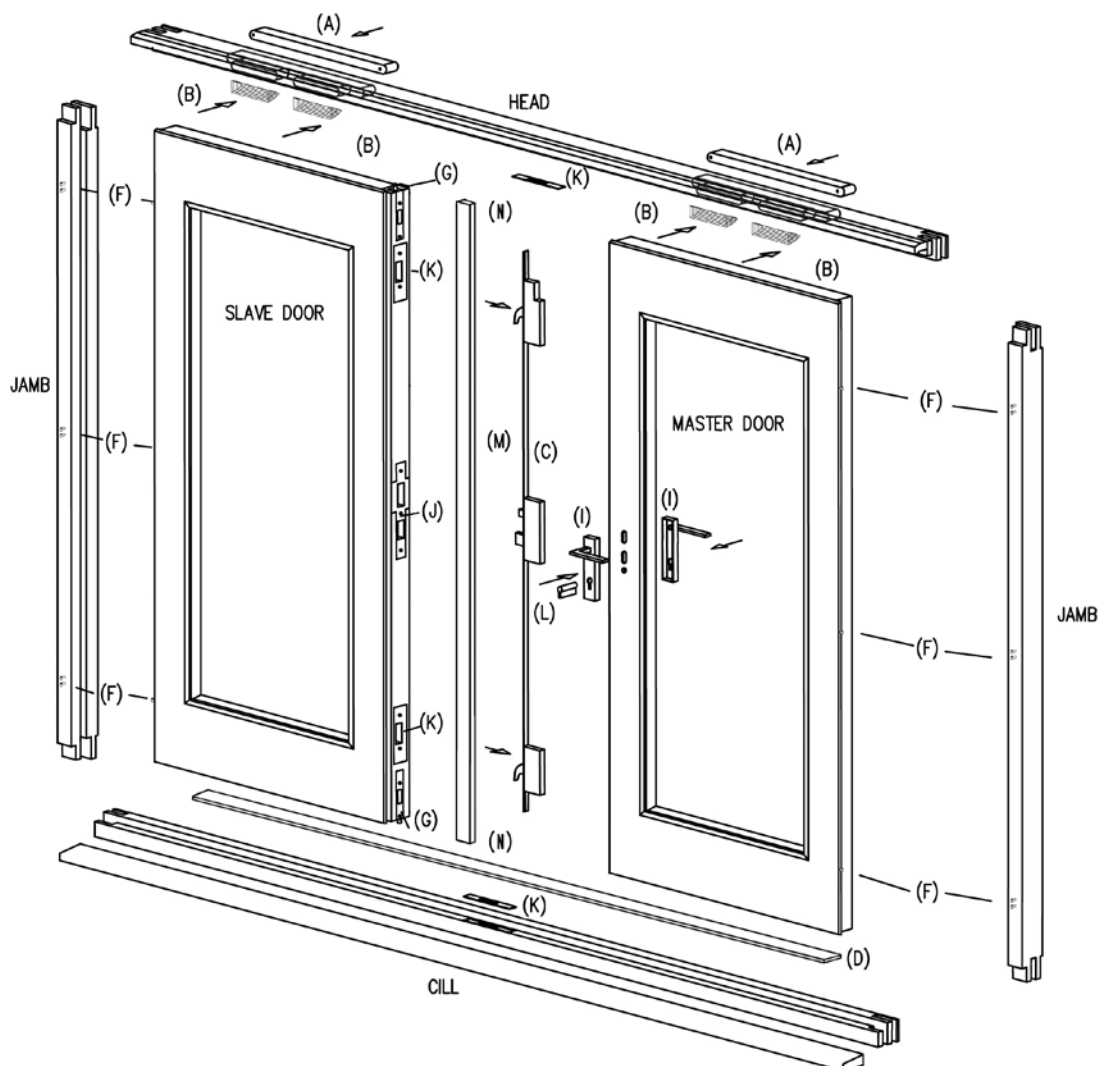

1 Frame assembly

The doorset can open in or open out, this is determined by which side the head drip is fitted to the head.

The frame is supplied with cut outs for hinges and pre-machined for the espagnolette and flush bolt keeps.

Assemble the frame on a level surface. Pilot holes are required prior to fixing screws.

Glue all comb joints with waterproof adhesive and screw through the joint with 5.0 x 90mm screws 10 gauge (not supplied).

Check the frame is square and temporarily brace as necessary to ensure stability of the frame (See Fig 1).

Glue and screw all joints.

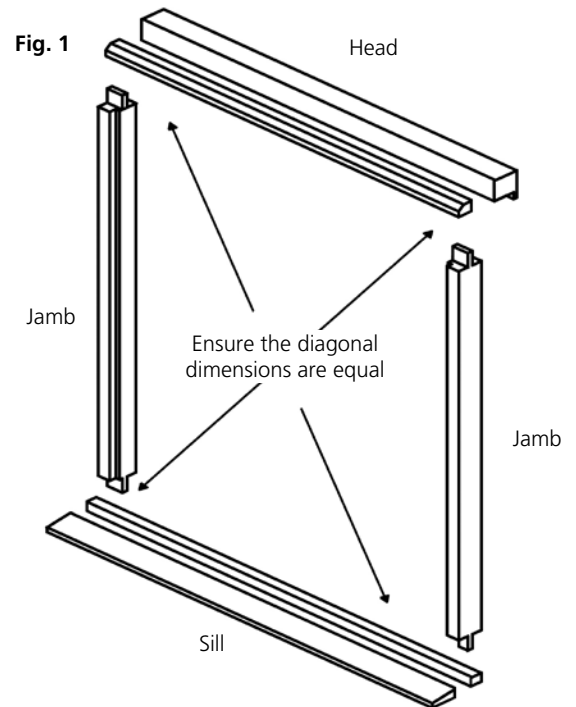

2 Fitting sill and head plant

The French doorset can be either open in or open out. Using 4.0 x 40 frame screws, fix the sill and head plant as detailed in Fig. 2.

Using 4.0 x 30 vent screws fix in to the head as detailed in Fig. 2a.

Screw in rain defectors.

Please note, flexible sealant must be used when joining head and sill components.

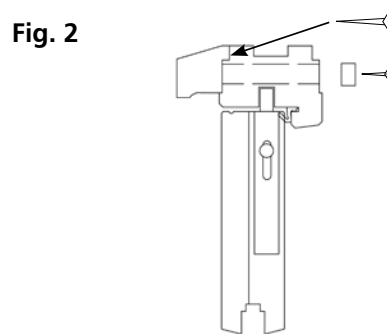

Open out

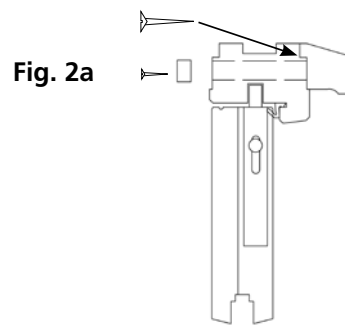
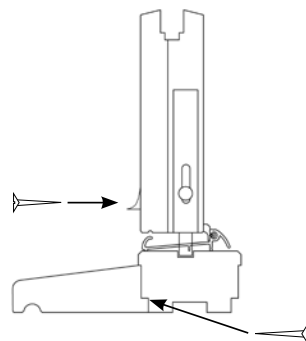
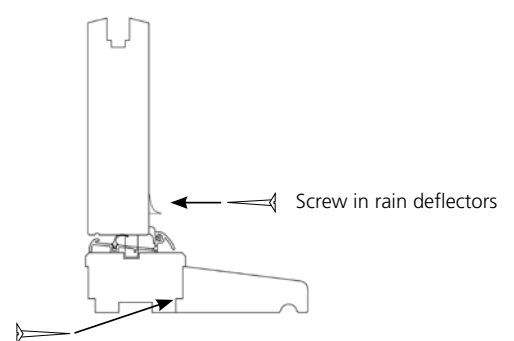

Fig. 2a

Open in



3 Preparing the frame

Letters in brackets refer to exploded drawing and checklist.

Prior to fitting the frame into the brickwork, fit the trickle vents (A) and grills (B) into the head of the frame.

The hinges should be fitted into the recesses in the jamb (See Fig 4). Hinges should be screwed into jamb using 4.0 x 40 hinge screw.

Apply a bed of silicone seal along the sill before screwing the threshold.

Screw the aluminium threshold to the sill using 4.0 x 30 threshold screws (See Fig 5).

Screw in the top and bottom keeps (K) (See Fig 6) using 4.0 x 30 keep screw.

Fig. 4

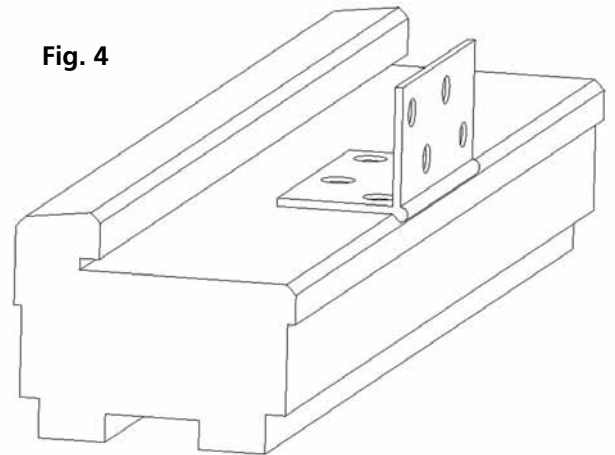

Fig. 6
Open in

Open out

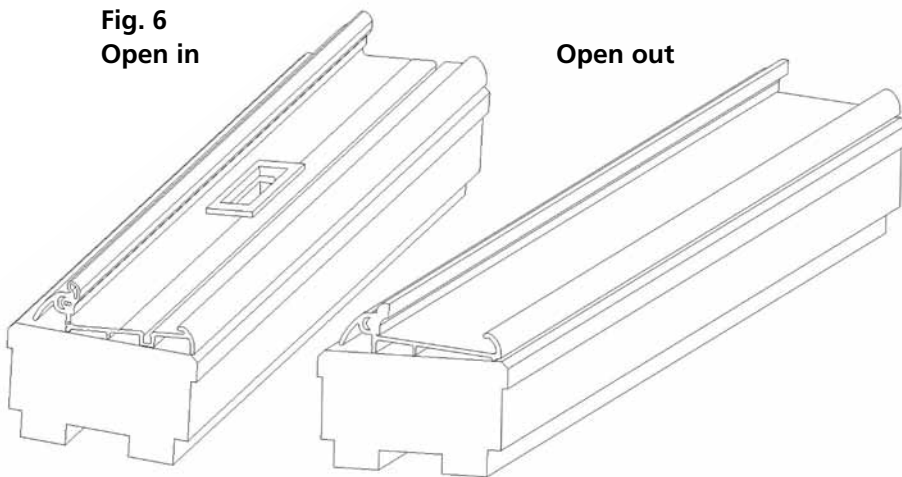
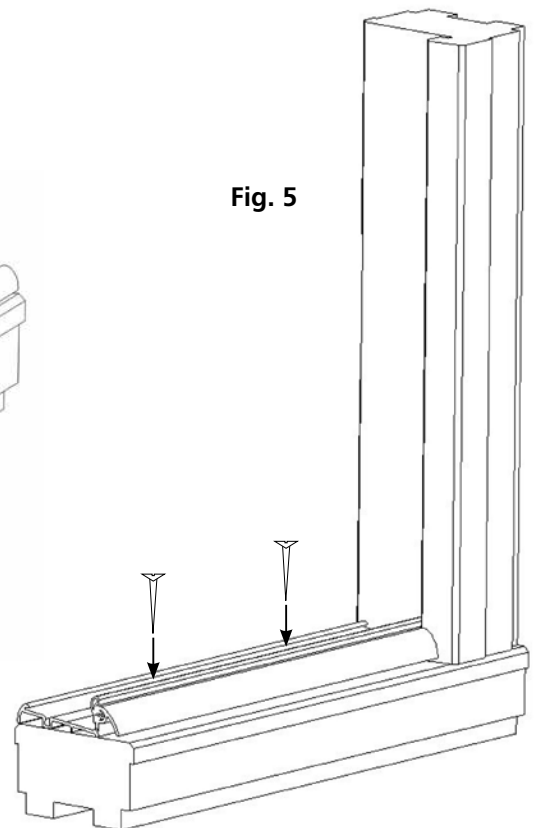

Fig. 5



4 Installing the frame

Prior to installing the frame, check the building structure for a secure fixing position. This is due to the weight of the finished door set. Then use a suitable fixing method (eg. frame fixings/ties).

Fixing of the frame and fitting of any dampproof course and bedding is the responsibility of the installer, and must be carried out as in normal building practice to prevent water penetration.

Jambs must be straight when fixed to the brickwork.

Build-in or fit the frame into the masonry opening ensuring that the sill is level and diagonal measurements equal (see Fig 6). Check the squareness of the frame and that the jambs are plumb.

Using the brickwork fixing screws, fix through the jambs as shown below.

*Frame should be set in the reveal to such an extent that the sill overhangs the brickwork.

Use appropriate sealer to fill gaps between frame and brickwork on all sides.

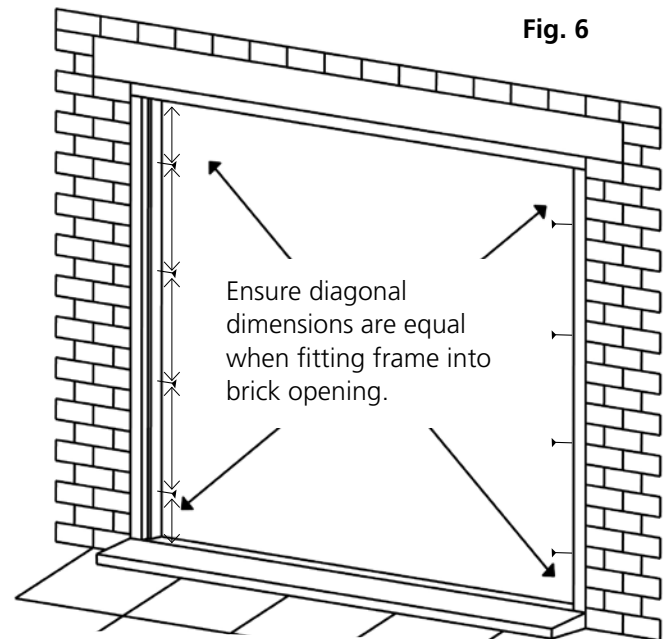

5 Hanging the doors

The doors can be either left hand hung or right hand hung, this is determined by rotating the door 180°.

Carefully offer doors up to the hinges that were fitted to the jambs in stage 4.

The doors need to be drilled to take the hinge flag, once in place screw into position using 4.0 x 40 hinge screw.

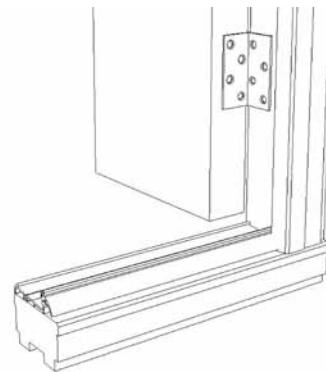

6 Fitting cylinder lock and espagnolette locking system

Once the handing of the door is determined and therefore the top and bottom edges of the doors are established, additional holes need to be prepared through the central mortise as shown on diagram on right.

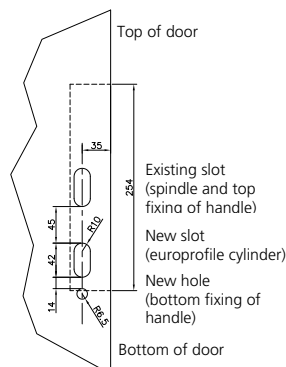

To fit the espagnolette, locate the centre of the lock (C) into the pre-machined mortice holes, using 4.0 x 30 lock screws, setting the hook bolts to the retracted position. Fig 7

Do not tamper with the two screws directly above the top hook as these hold the reverse gearbox to the Espagnolette.

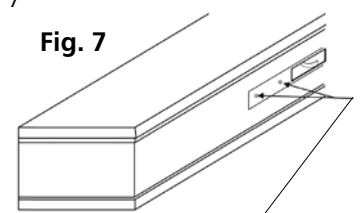

7 Fitting the lock keeps

Fix keep plates in to slave door stile using 4.0 x 30 keep screws.



8 Fixing finger bolts

Fix finger bolts to the slave door stile using 4.0 x 30 finger bolt screws.

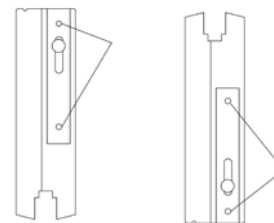

9 Fitting the handles

Fit door handles (I) and cylinder lock (L) (See Fig 8) and test lock system.

Failure to do these operations will cause the locking mechanism to fail, and the doors will become in-operable.

Close the doors and engage the locking system to check its operation.

Fig. 8

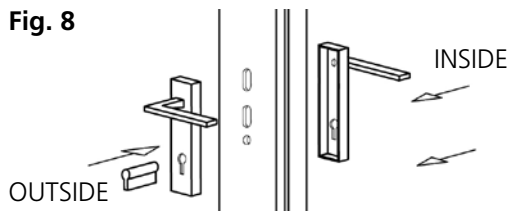

10 Fixing cover spline

Fit end caps to both ends of cover spline (M) using single screw on each. Glue and pin cover spline in position on slave door face, overlapping the edge to cover the gap between meeting stiles and set 14mm below top edge of the door.

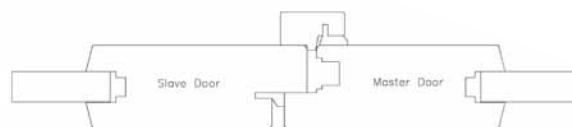

11 Finishing & maintenance

Factory finished product requires no further decoration other than touching up damage that may have occurred during installation, The oak unfinished doorset must be primed or sealed immediately after delivery/ collection and prior to installation. This should be carried out in dry weather conditions. All faces and edges should be suitably sealed immediately after un-wrapping. Before priming or sealing lightly sand off any handling marks and variations caused by exposure and ensure the surface is dust free. For paint finishes aluminium primers can provide suitable blocking properties. Microporous paints and medium or high build wood stains are recommended for all exterior products. The manufacturer's instructions should be followed.

'Low Build' stains, varnishes, Danish Oil or any other finishes should **not** be used. Pigmented translucent finishes generally perform much better than clear.

It is recommended that dark coloured stains or paint should be avoided if the doorset is exposed to the full heat of the sun, particularly on south or south west elevations. Dark finishes increase surface temperatures and cause excessive drying out; this can lead to surface deterioration requiring more regular maintenance.

By taking care of your patio with the following simple actions, it will give many years of trouble free service.

1. Ensure doors are kept clean and free of obstruction.
2. Lightly lubricate moving parts periodically, at least once every 12 months.
3. Unless supplied in light build paint or stain finish, door and frame require decoration on site.
4. Redecorate all timber components every 2 years, or more frequently if required. It is particularly important to touch up any minor damage properly.

12 Guarantees

In keeping with our quality policy, JELD-WEN offers the following guarantees on its products. These guarantees are subject to JELD-WEN UK Terms and Conditions of Sale. Defects that are caused in whole or in part by failure to adhere to JELD-WEN UK recommendations relating to storage, handling, installation, decoration, glazing and maintenance, are not covered by the guarantees below:



Exceptional wear and tear of hardware through extreme use is not covered. JELD-WEN will accept no responsibility for products cut down in size after receipt, or when utility or structural strength is impaired in fitting or application of hardware.

Hinges, aluminium rails and other hardware fitted must never be painted, and must be kept clean and lightly lubricated at all times. Use Vaseline or neutral oil. Keep rivets and moving parts lightly lubricated. Lubricate at least once a year, in coastal areas and/or places with high pollution, clean and lubricate more often.

All joinery shall be installed correctly in accordance with normal trade practices and adequately maintained in service.

Standard insulating glass units must not be used in areas of high humidity, e.g. swimming pools or similar. They should also not be used within 300mm from a door or within 800mm of the floor.

The decorative finish applied to external joinery must be maintained in service and moisture must not be allowed to penetrate into the timber throughout its life.

Regular maintenance of the paint or stain finish of the product is essential for the long-term performance of all the components of your patio doorset. The period between maintenance checks will vary depending on the type of paint or stain finish and also the local conditions for the site. External joinery products must be cleaned at a maximum of six monthly intervals using a mild non-abrasive cleaner and soft cloth. Both internal and exterior faces should be cleaned.

Make regular checks to ensure that any drainage holes, channels and spaces are kept clear. Use a soft flexible brush or pipe cleaner with care to remove obstructions.

Finished joinery is guaranteed for 2 years against blistering, cracking, flaking or erosion excluding natural resin exudation and movement around knots. Annual inspection should be made and touching up carried out as necessary in areas of wear and tear (for example, exposed areas of sills or where the paint film has been breached).

Guarantees to the finished product are also on condition that:

- No physical or chemical damage to the doorset or coating has occurred
- No repairs or alterations to the surrounding buildings have occurred which are detrimental to the joinery performance.
- No failure of the coating has occurred caused by failure of ansillary products, or glazing.
- No damage to the coatings has occurred prior to, or during, installation.
- No damage to the coating has occurred, caused by bad maintenance of the building or poor design of the building.