

OAKFOLD & WELLINGTON FOLDING SLIDING PATIO FITTING & FIXING GUIDELINES

OAKFOLD



SELECTION

WELLINGTON



STANDARD



CAUTION SAFETY: This product needs to be installed by a competent tradesperson with assistance. Two people are required to carry out the installation, as some components are heavy. The outer frame requires fixing to the supporting structure above the opening. The opening **MUST** be capable of carrying the load of the doorset in all conditions.
IMPORTANT: See notes on page 2.

Contents

Patio Doorsets Fitting, Finishing and Care Instructions	3	Fitting the carrier & pivot hinges	31
Doorset Lintel Specification	5	Hanging the doors	32
Tools Required	6	Fitting the keeps & blanking plates	33
What you receive	6	Fitting the handles	33
Pack contents	7	Adjusting the doors	34
Structural opening	10	Fitting the sliding bolts	35
Preparing the sill for assembly	10	Fitting the ventilator	35
Frame assembly	11	Finishing & maintenance	36
Fixing frame in opening	11	Guarantees	38
Fixing the head	12	Troubleshooting guide	39
Preparing the doors ready to receive the hinges	13		
3L	13		
3R	15		
1L3R	17		
3L1R	19		
5L	21		
5R	23		
5L1R	25		
1L5R	27		
3L3R	29		
Fitting the multipoint lock	31		

IMPORTANT:

You should have already received a copy of the Sliding Folding pre-installation information leaflet, this can be downloaded at www.jeld-wen.co.uk if required.

Installation of these patio doorsets should be carried out by a minimum of two people.

Prior to installing this doorset please ensure you have carefully inspected each package. In the unlikely event you discover any damage or defect do not proceed to fit until you have notified JELD-WEN (0845 122 2893 option 2).

This doorset and all its components should be stored in a dry flat location prior to and during installation.

Introduction

Thank you for purchasing a sliding folding patio door-set from JELD-WEN.

Your Oakfold/Wellington Doorset can be arranged to slide either from the left or the right hand side. Wherever possible all machining has been completed for you, however there are certain operations you will need to undertake once you have determined which handing you require. door leaves will need to be pilot drilled for the hinges as well as routing out to receive the lock cylinder and handle set.

Information showing the position of the hinges and lock are contained within these instructions.

Depending on the product you have purchased i.e. Factory finished or unfinished, varying levels of additional finishing may be required. Where additional machining has been carried out all untreated surfaces should be suitably decorated. **Unfinished products should be fully decorated prior to installation. Please now refer to pages 3-4 for more information.**

These doors use a top hung carrier system and therefore require an adequate structural opening supported by a lintel. See Doorset Lintel Specification Guide on page 5.

All loads are taken by the headtrack providing smooth light operation and long life. The top hung system avoids the build up of debris restricting operation that occurs with many bottom rolling systems.



JELD-WEN factory glazed windows and external doorsets have been CE marked as directed under European law. Each product is labelled and full Declaration of Performance can be downloaded from www.jeld-wen.co.uk

1 Patio Doorsets Fitting, Finishing and Care Instructions

Unfinished, Patio Doorsets

These doors are manufactured using an engineered construction with veneered faces for greater stability. The timber used is a natural sustainable product, and if not correctly decorated is subject to changes caused by variation in humidity and temperature. If these doors are exposed to these changes without the correct decoration, movement or distortion such as swelling, shrinking, warping or splitting will occur. Warp in the plane of the door will only be considered a defect if it exceeds 6mm when measured, as deviation from a straight edge on the suspected concave surface of the door in its installed position.

Oakfold patio doorsets are supplied either unfinished or fully factory finished.

Wellington patio doorsets are supplied fully factory finished in white.

Handling

When handling these doors care is required to avoid physical damage, use clean gloves and do not drag doors across each other or other surfaces.

Biocide Regulations 1st September 2013

JELD-WEN exterior joinery is treated with an approved wood preservative and protected against wood decaying fungi.

For Wellington patio products the active ingredients are Carbamic acid, butyl, 3-iodo-2-propynyl ester.

For Oakfold products the active ingredients are copper carbonate and Didecyldimethylammonium Chloride.

Preserved wood should not be cut or otherwise reworked as this will expose un-preserved wood. Any surface which is exposed by cutting or drilling must be retreated with an HSE approved cut end preservative. Follow the instructions for safe use on the manufacturers' safety data sheet.

Storage

Doors must be stored in a flat position, and not on an edge or an end. They must be on a level surface and kept clear of the floor on at least three level bearers. The bearers must be longer than the width of the door, and they must be stored in a clean, dry location and should be fully sealed before use. Exposure to sunlight, UV light or extremes of humidity and heat must be avoided, and doors should never be stored in areas which are subject to extremes in temperature. The storage area should have good ventilation and must not have been recently plastered. Special attention should be made in a centrally heated or air-conditioned building where moisture content could build up. Warranty claims for twisting, bowing, shrinking, or swelling that are moisture related (while the doors are not sealed according to our guidelines) will be rejected.

Sealing

Prior to priming or sealing, lightly sand any handling marks or variations caused by exposure and ensure the door is dust free. Do not use wire wool or other sanding materials with steel or iron elements. Knotting solution must be reapplied if knots become visible. It is important that the door is then fully sealed using a suitable base sealer on both faces and all four edges, plus any cut-outs for locks, hinges and letter plates etc. Use two coats of base sealer or primer. Failing to seal doors as suggested in our instructions will invalidate any Warranty claims.

Hanging the door

Prior to hanging this door, inspect for damage and do not proceed to work on it if any damage or defect is evident. Installation of the door constitutes acceptance of aesthetics quality. Never hang a door before applying a protective coat of basecoat stain/primer. All lock or handle cavities should be kept to a minimum size and situated away from the mid rail joint, these areas must then be re-sealed. The door must be fully decorated prior to hanging.

1 Patio Doorsets Fitting, Finishing and Care Instructions cont...

Decoration (unfinished doorsets)

All door leaves and frame components must be finished with high build micro-porous based stains or paints, with particular attention to ensure that any end grain is fully sealed. Our doors are not suitable for varnishes, waxes, polishes or oils as these products do not correctly seal the door. Three top coats of a branded stain or paint are satisfactory, but door must be treated in accordance with the stain/paint manufacturer's instruction. A light sanding between coats will provide the best finish, and adequate drying time between coats must be allowed. Failure to follow these instructions will invalidate any claims for excessive movement or delamination.

'Low Build' stains, varnishes, Danish Oil or any other finishes must **not** be used. Pigmented translucent finishes generally perform much better than clear. It is recommended that dark coloured stains or paint should be avoided particularly if the doorset is exposed to the full heat of the sun on south or south west elevations. Dark finishes increase surface temperatures and cause excessive drying out; this can lead to surface deterioration requiring more regular maintenance.

We recommend that in areas of severe exposure, external doors should be protected by a porch or hood/canopy in addition to the recommended decorative finish. Regular maintenance of this door should be made to prevent deterioration of the wood, its construction and the finish.

Maintenance of fully finished products

JELD-WEN fully finished doorsets have a high build factory applied paint (or stained) finish. It is tough, durable and micro-porous allowing the timber to breath, protecting build up of excess moisture under the coating.

Modest maintenance of the paint coating is important to ensure the long service of these products.

Step by Step maintenance guide

1. Bi-Annual Inspection: The paint finish should be inspected annually for damage, typically caused by a window cleaners ladder or objects being passed through the doorset or window.

If damage is found it must be dealt with promptly by sanding back to the undamaged frame and touching up with a matching micro-porous paint and top coat.

2. Planned Maintenance: for all factory finished products will depend on your location and exposure – maritime or industrial areas will require more regular decoration than sheltered inland climates. Please refer to www.jeld-wen.co.uk for further information.

The first maintenance cycle should be carried out, regardless of the appearance of the doorset. The original paint finish in exposed areas will have worn away to around half its original specification and will need to be restored back to its original state. Simply wash the frame down with a dilute soap solution, dry and lightly rub down the surface with fine 'wet and dry' sandpaper, grit (280 to 400) grade. Dust off and clean using a damp cloth removing any remaining surrounding dust, then apply one top coat of micro-porous paint* over the exposed surfaces.

There should be no need to paint rebates or concealed faces as these should be in good condition and no erosion should have occurred. The doorset finish should then be in good condition until the next planned maintenance.

* Micro-porous paint can be used that are either water or solvent (oil) based. Manufacturers instructions must be followed paying particular attention to temperature at the time of application.

Condition of Sale

In the event of this door being proven to have a manufacturing defect, where a replacement is needed, the liability of the seller shall under no circumstances exceed the price of the defective door. We shall not be held responsible for any incidental work or for problems resulting from poor workmanship applied to our doors.

The foregoing does not affect your statutory rights.

For more information please refer to our website www.jeld-wen.co.uk

2 Doorset Lintel Specification

This information needs to be considered before the purchase of a folding sliding patio doorset.

Lintels must have at least 150mm bearing at each end. The overall length of a lintel should at least be the sum of the opening width plus 300mm (minimum). The safe working load for the lintel must not be exceeded by the combined loads imposed by the structure and the loads imposed by the folding sliding patio doorsets.

When specifying the lintel it will be also necessary to understand the type of construction, the type and thickness of the inner and outer leaves and the width of the cavity. It will also be necessary to understand the exposure rating for the site to determine if a cavity tray is required.

The additional loads imposed by the folding sliding patio doorsets will be a uniformly distributed load (UDL) of 0.5kN (approx. 50 kg) per metre run. Loads imposed by the structure will include loads from roof trusses, floor joists and masonry.

Head Fixing (see table below)

The load of the folding sliding patio doorsets will be applied through screws fixed through 5mm diameter pre-drilled holes along the centre of the external flange of the lintel.

Folding sliding patio doorsets are supplied with special fixings for use when fitting into a steel lintel only. For other lintel types please refer to a Structural Engineer before proceeding.

Jamb Fixing

The jambs should be fixed using the 5 fixings (provided) evenly spaced to suit the brickwork.

Sill Fixing

Fixing tie plates are supplied in the frame fixing pack, a minimum of three should be used to secure the sill. Ensure they are evenly spaced along the length of the sill and are fixed to the floor and sill correctly.

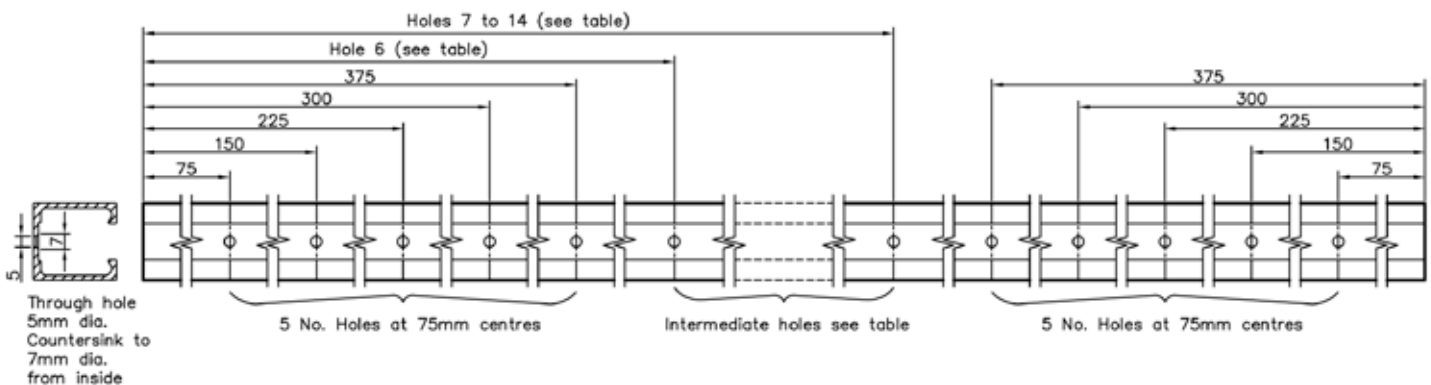

Table showing position of holes from hole 6

Doorset Size	Head plant length	Hole centre spacing	Hole 6	Hole 7	Hole 8	Hole 9	Hole 10	Hole 11	Hole 12	Hole 13	Hole 14
1800	1729	326	701	1027							
2100	2029	320	695	1015	1335						
2400	2329	395	770	1165	1560						
3000	2929	363	738	1101	1464	1827	2190				
3600	3529	347	723*	1070	1417	1764	2111	2458	2805*		
4200	4129	375	752*	1127	1502	1877	2252	2627	3002	3377*	
4800	4729	398	773	1171	1569	1967	2365	2763	3161	3559	3957

* offset for first and last holes increased to avoid decimal places in dimensions

Building Regulations:

Please consult with your building designer to ensure compliance with current building regulations such as Approved Documents L&F.

Replacing patio doorsets is notifiable work and MUST either be carried out by a FENSA or other registered installer, or with prior Building Control approval.

Registered FENSA companies can be found at www.fensa.co.uk.

Addition: Part M: These doorsets are not suitable for primary access under this regulation. If this is required you should consider a JELD-WEN French or Single doorset. You can view the full range of at www.jeld-wen.co.uk

3 Tools Required

The following tools and items are required to carry out the installation of the doorset.

- Spirit level
- Masonry Drill
- Screwdriver
- Measuring tape
- Appropriate Silicone sealant
- Mallet - Rubber headed
- Frame packers if required
- 13mm timber drill bit (for bottom bolt on handle)
- Timber drill bit 3mm (pre-drilling)
- Timber drill bit 6.5mm
- Masonry Drill bit 3.5mm Dia x 125mm length min
- Masonry Drill bit 8mm Dia x 125mm length min
- Steel cutter 3.5mm Dia x 125mm length min (Screwfix reference)
- Router bit 10mm Dia
- 20mm flat bit (for eurocylinder)

4 What you receive

The doorset and all its components are delivered on a pallet, check quantities on your delivery ticket are the same as those on the pallet.

If there are any items missing phone JELD-WEN on: 01664 484500



4 What you receive cont...

Pallet contents: Door leaves (boxed individually)

Wellington

- 1800 - 3 Doors
- 2100 - 3 Doors
- 2400 - 3 Doors
- 3000 - 4 Doors
- 3600 - 5 Doors
- 4200 - 6 Doors



Oakfold

- 1800 - 3 Doors
- 2100 - 3 Doors
- 2400 - 3 Doors
- 3000 - 4 Doors
- 3600 - 5 Doors
- 4200 - 6 Doors
- 4800 - 6 Doors



Width	Door/Config	A	B	C	D
1800	3L	1	1	1	
	3R	1	1	1	
2100	3L	1	1	1	
	3R	1	1	1	
2400	3L	1	1	1	
	3R	1	1	1	
3000	1L3R	1	1	1	1
	3L1R	1	1	1	1
3600	5L	2	2	1	
	5R	2	2	1	
4200	1L5R	2	2	1	1
	1R5L	2	2	1	1
Wellington Only	3L3R	2	2	1	1
Oakfold Only					
4800	1L5R	2	2	1	1
	1R5L	2	2	1	1

5 Pack contents

Hardware Pack x 1



Contents



5 Pack contents cont...



Fitting Instructions Booklets

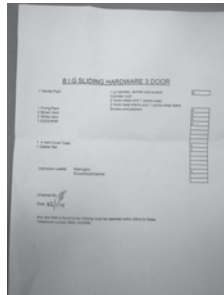

Hardware checklist



Vents



Keeps



Handle Pack



Fixing Frame Pack



Foam Gaskets Pack



Cylinder



Screw & Vent Caps

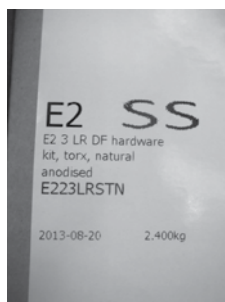

Box of sliding folding hardware



Sliding Folding Hardware



Sliding Folding Hardware

Frame Fixing Pack (See page 9 for a breakdown of contents)

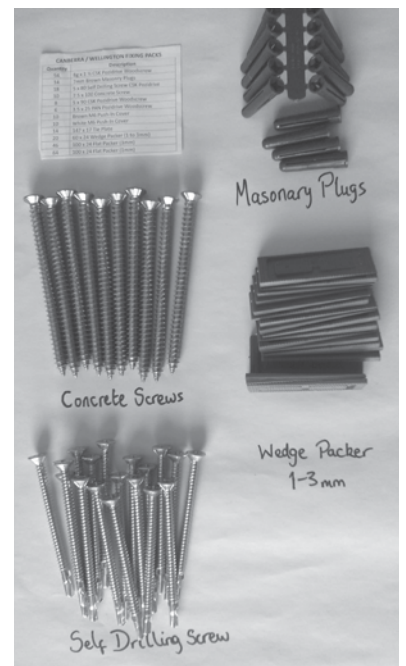
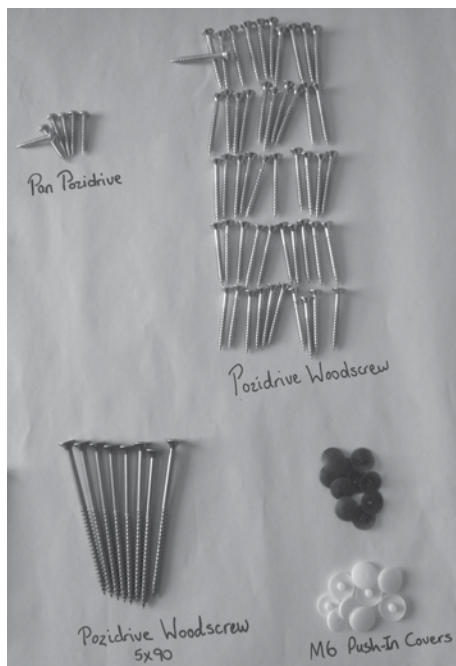

5 Pack contents cont...

Frame Fixing Pack Contents

- 54 x 3.5 x 37 CSK Pozidrive Twinhead Woodscrew
- 14 x 7mm Brown Masonry Plugs
- 18 x 5 x 80 self drilling screw CSK Pozidrive
- 10 x 100mm Frame Fixings
- 8 x 5 x 90 CSK Pozidrive Woodscrew
- 6 x 3.5 x 25 PAN Pozidrive Woodscrew
- 10 x Brown M6 push-in cover

- 10 x White M6 push-in cover
- 14 x 147 x 17 Tie Plate
- 20 x 100 x 24 Wedge Packer (1 to 3mm, grey)
- 46 x 100 x 24 Flat Packer (3mm, white)
- 64 x 100 x 24 Flat Packer (1mm, green)

The number of components in the frame fixing pack suit the installation of a 4.8mm wide doorset. For other widths there will be excess fittings.

Threshold Pack x 1

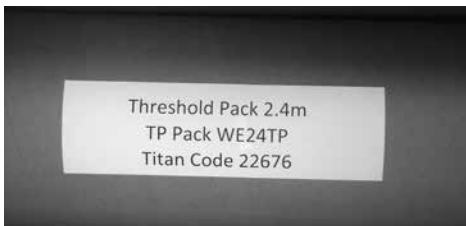

Head track - Vent slots
Multipoint Espagnolette Lock



Aluminium Threshold

Frame Pack x 1



Wellington 1800mm frame pack



Oakfold 1800mm frame pack



Frame Pack (opened)



Head



Jamb x 2



Timber Sill
Section

6 Structural opening

To ensure correct operation of the Sliding Folding Patio Doorset it is necessary for the top track to be fixed to a suitable structure that is capable of supporting the loads imposed by the doors, glazing and hardware. The Pre-Installation Information Sheet, that you should have already received, gives information relating to these loads.

It is recommended that the opening into which the Sliding Folding Patio Doorset is to be installed is 10mm larger in both height and width than the overall doorset sizes that are given in the table below.

Module Size	Actual Frame Width	Actual Frame Height
1800mm	1794mm	2094mm
2100mm	2094mm	2094mm
2400mm	2394mm	2094mm
3000mm	2994mm	2094mm
3600mm	3594mm	2094mm
4200mm	4194mm	2094mm
4800mm	4794mm	2094mm

Structural Opening

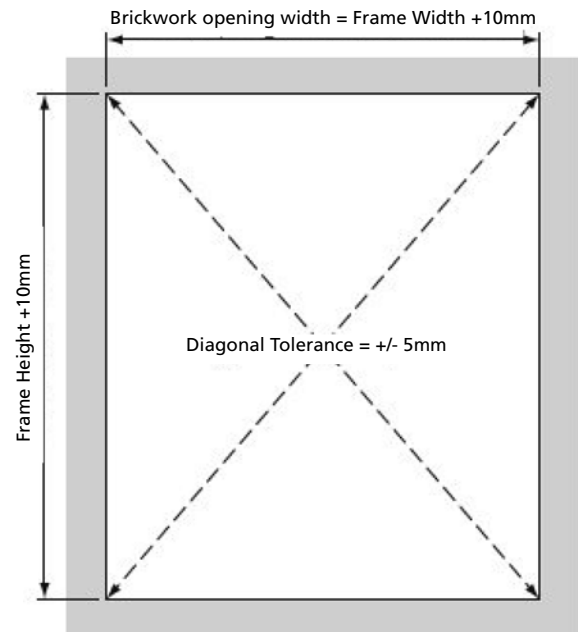

7 Preparing the sill for assembly

- A silicone bead should be applied continuously along the full length of the timber sill section. It should be applied to the face that is in direct contact with the aluminium (see diagram).
- Using a 3mm drill bit, drill a 25mm deep pilot hole through the underside of the aluminium sill and timber assembly. These holes should be 100mm, 250mm and 400mm from each end. The remaining length of sill in between then needs to be divided up in to equal sections, (no more than 400mm centres) and then pilot drilled in the same manner (see diagram).
- Secure the fixing ties to the underside of the frame using the 3.5 x 37mm screws at the prepared pilot hole positions. Ensure the screws are fully tightened in to the timber.

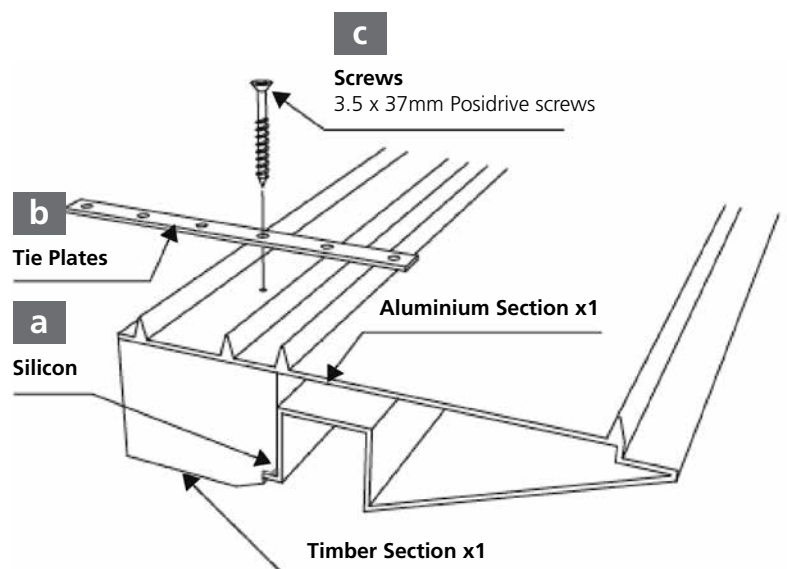

8 Frame assembly

Having completed the sill assembly the frame components can now be assembled.

Insert the metal head track into the timber head section. Ensure that the vent hole cut outs in the metal track align with the slots in the head section.

Depending on the configuration of your doorset there will either be one cut out at one end or a cut out at both ends to enable you to insert the carriers later.

Depending on the configuration you select the cut out may not necessarily be at the same end as your pivot hinge

First apply the self adhesive foam pads to the head and jambs where indicated in the diagram. D & E & F Pilot drill screw holes at the pre-marked positions using a timber 3mm drill bit.

Using the 5 x 90mm woodscrews provided fix through jambs into head and from the underside of the sill. *Do not over-tighten.

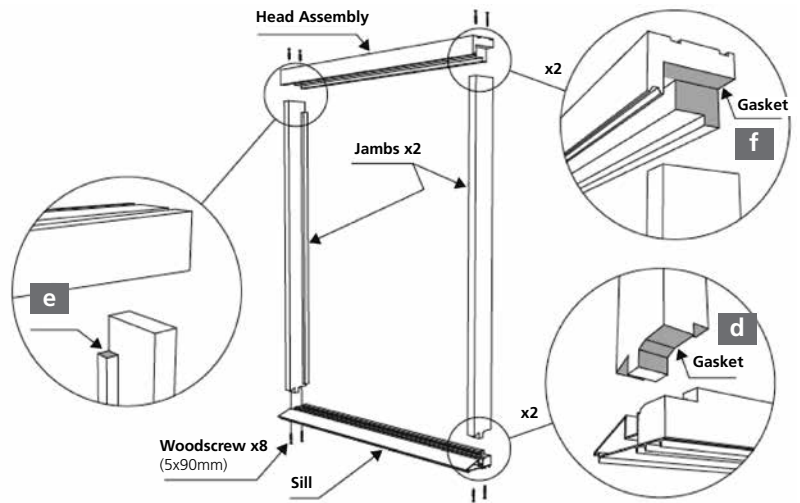

Check the corners of the frame are square and the diagonals of the frame are within 5mm of each other. If not loosen screws adjust and re-tighten.

The frame is now ready to be lifted into the opening.

9 Fixing frame in opening

1. Fixing Frame in Opening

Offer the frame into the structural opening and adjust its position to ensure that the fixing holes in the head track are in the correct position to match the supporting structure (i.e. in the centre of the external flange of a lintel). Also, make sure the sill sits exactly in the brick opening as shown below.

Do not screw into place

Note: Jamb fixing points may be hidden behind keep or blanking plates.

Note: The sill drain positions are at the front edge circled below and must be kept clear of obstruction to allow free drainage. In certain refurbishment projects it may not be possible to position the sill exactly as shown. In this instance it is essential that drainage can occur following installation. You will need to determine this on site.

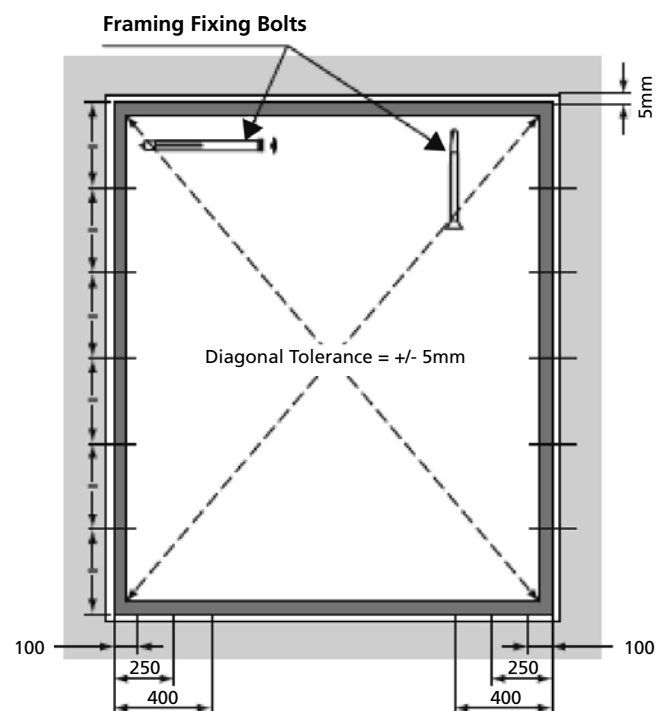
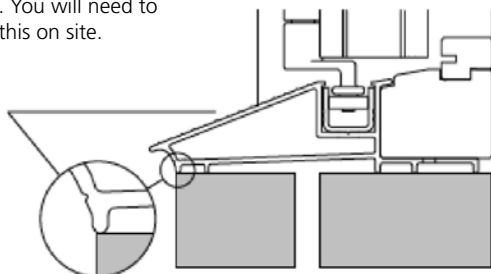

2. Pre-drilling

All fixings to lintel are essential and must be completed before doors are fitted.

Once the position of the frame is correct using the pre-drilled holes in the head track as a guide mark the screw positions on the lintel. Remove the frame from the opening. Pre-drill the lintel with a 3.5mm diameter hole to allow drilling of any masonry above lintel.

The masonry will need to be drilled to a depth of at least 40mm to receive the fixing screw that passes through the head track in to the lintel. Replace the frame in to its original position. It will take 2 people to lift the frame and re-align it with the pilot holes.

3. Locating the Frame

When the position of the frame is correct place 5mm of packing above each jamb between the head and the top of the structural opening then place packers below the sill until the head packers are tight. Using a spirit level, check that the head and sill are level, make adjustments as necessary, then pack at each of the sill fixing points ensuring that the sill remains level.

4. Fixing Jamb

Use the spirit-level to check that the jambs are vertical. Position packers at each of the jamb fixing points ensuring that the diagonals of the frame remain within 5mm of each other.

While the frame is temporarily secured by the packers, and ensuring the frame is not knocked out of position, drill 8mm diameter holes 70mm into the structure either side of the frame, we recommend five fixings equal distance apart on the length of the jamb. Insert the frame fixing bolts through the jambs into the structure and tighten ensuring the jambs are not distorted.

5. Fixing the Sill

For each of the sill ties locate a suitable fixing point and drill for the 7mm masonry plug then fix the sill ties using the plugs and the remaining 3.5mm x 37 woodscrews.

DO NOT secure the sill by inserting screws through the drainage holes located in the bottom track.

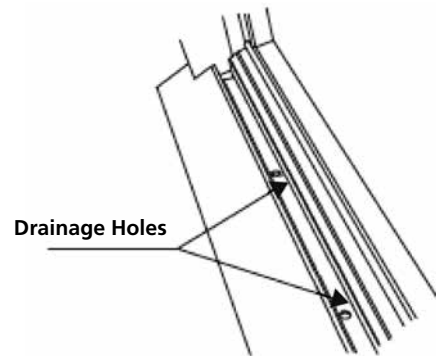

Check once more, that the jambs are vertical, that the head and sill are level and that the diagonals are within 5mm of each other.

10 Fixing the head

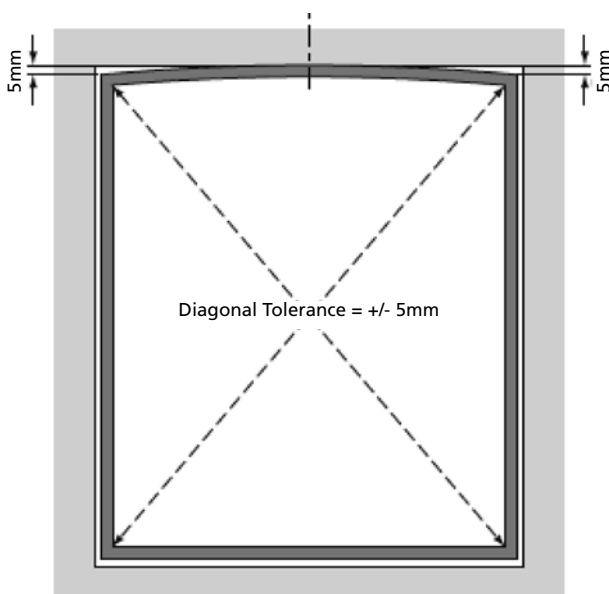

In order to produce a camber in the head track as shown opposite the fixings to the head need to be fitted in stages reducing the gap between the head and the supporting structure at each stage.

Starting with the two outer fixings offer up the fixing screw and tighten until it is just pulling. **DO NOT FULLY TIGHTEN AT THIS STAGE.**

At a central fixing point lightly tighten a screw until the head is pulling close to the lintel.

Working from the jambs inwards lightly tighten screws varying the thickness of packing between the head and the lintel creating a slight upwards curve to the head varying from approximately 5mm at each jamb to zero in the middle.

Once the correct curve of the head has been achieved tighten the fixing screws. **DO NOT OVERTIGHTEN.**

11 Preparing the doors ready to receive the hinges

Note: The edges of the door leaves will need to be pilot drilled in preparation for the hinges to be fitted. Using the hinges as a template, position the hinge as shown in the relevant diagram (P13-21) and drill a hole 3.0mm diameter and 30mm deep. Ensure that the knuckle of the hinge is pressed firmly against the correct face of the door. **Ensure flat hinges and cranked hinges are not mixed on the same door edge.**

3L

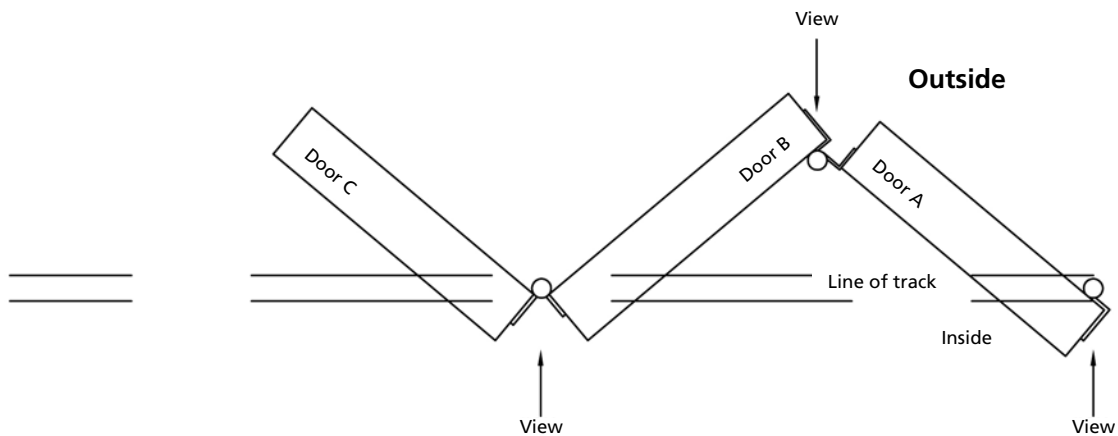
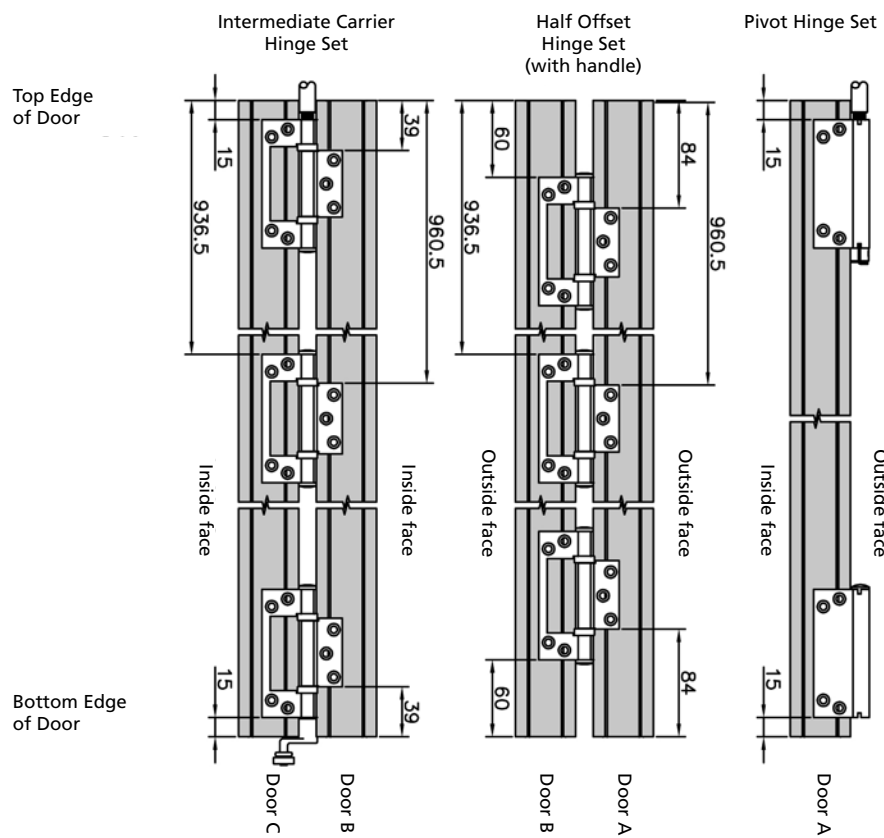

3L

Wellington/Oakfold Patio Doorset

Door Size: 1800mm(& 2100 & 2400) x 2100mm

Door and Hardware Arrangement: 3L

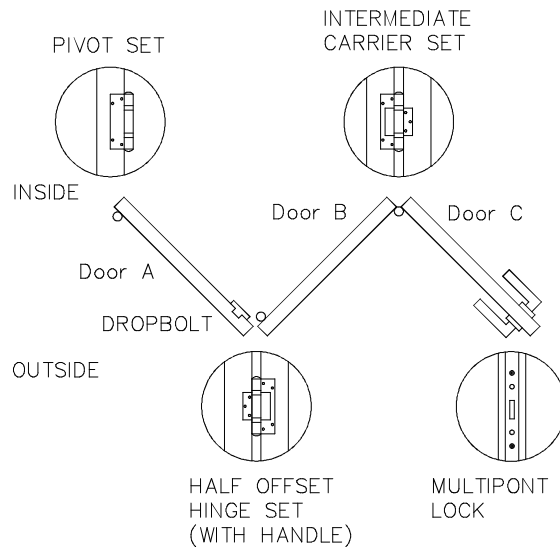

PACK 1 DOORS

ITEM	QUANTITY
Door A	1
Door B	1
Door C	1

PACK 2 FRAMING

ITEM	QUANTITY
HEAD ASSEMBLY	1
SILL ASSEMBLY	1
LEFT-HAND JAMB ASSEMBLY	1
RIGHT-HAND JAMB ASSEMBLY	1

PACK 3 DOOR HARDWARE

ITEM	QUANTITY
PIVOT SET	1
HALF OFFSET HINGE SET (WITH HANDLE)	1
INTERMEDIATE CARRIER SET	1
DROPBOLT (KEYED)	1
DROPBOLT (NON-KEYED)	1
DROPBOLT CUPS	2
DROPBOLT CUP BLANKS	2

PACK 4 HARDWARE PACK

ITEM	QUANTITY
HANDLE	1
35/35 ZINC CYLINDER	1
35 BS DOOR LOCK (3 BOLT)	1
CENTRE KEEP	1
CENTRE KEEP (BLANK)	1
HOOK KEEPS	2
HOOK KEEPS (BLANK)	2

PACK 5 FIXING PACK

ITEM	QUANTITY
WELLINGTON/OAKFOLD FIXING PACK	1

3R

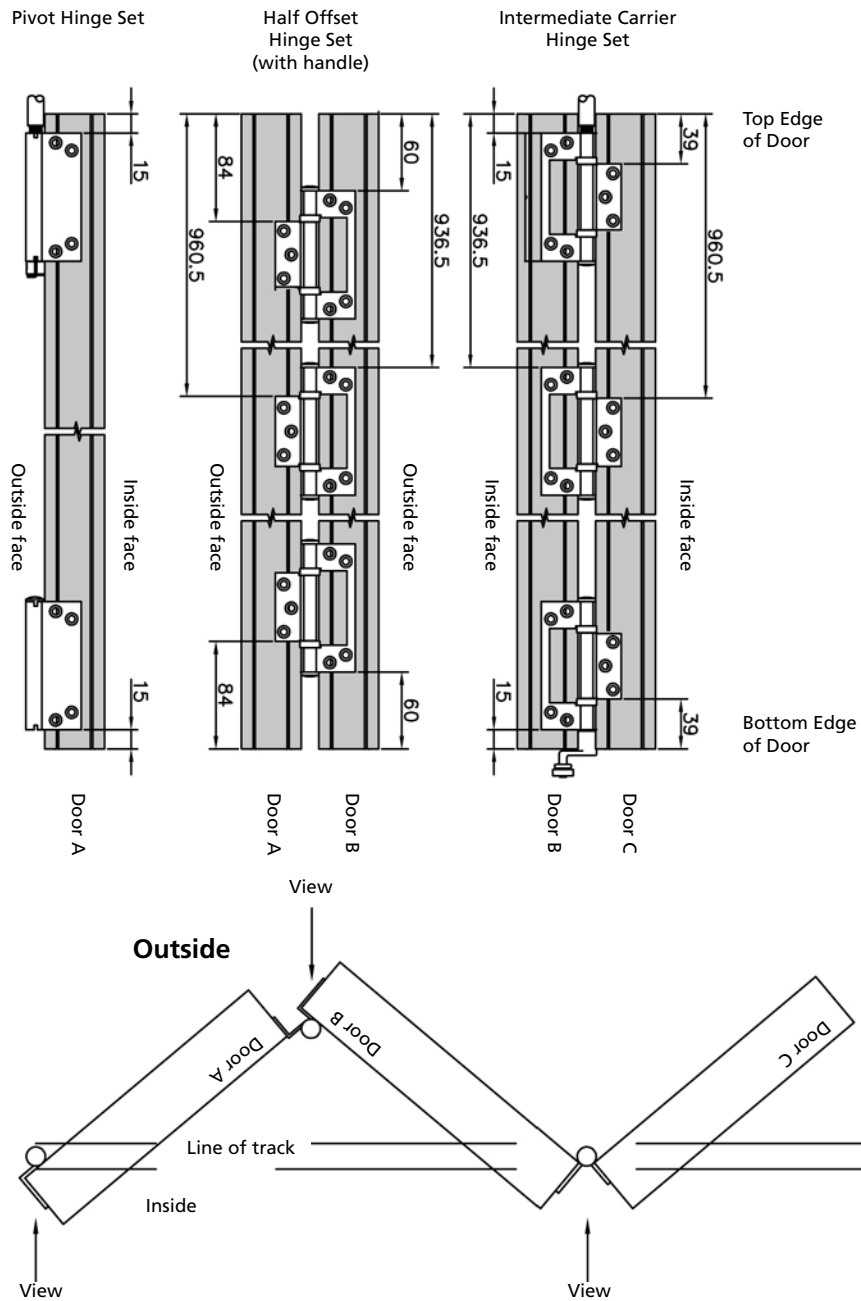

3R

Wellington/Oakfold Patio Doorset

Door Size: 1800mm(& 2100 & 2400) x 2100mm

Door and Hardware Arrangement: 3R

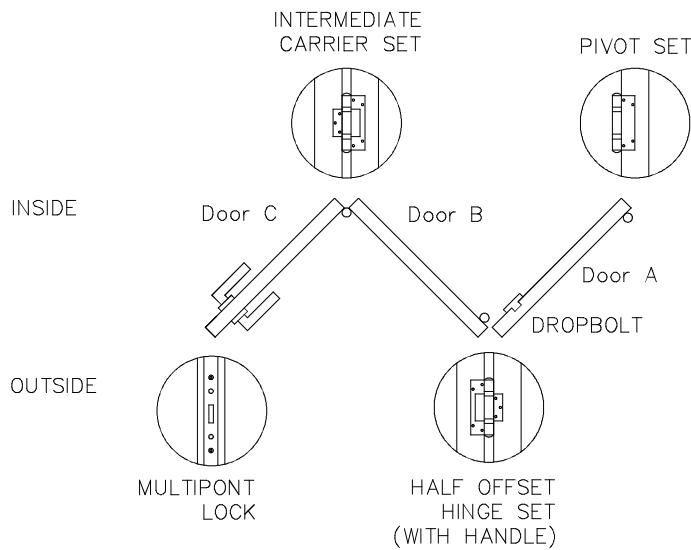

PACK 1 DOORS

ITEM	QUANTITY
Door A	1
Door B	1
Door C	1

PACK 2 FRAMING

ITEM	QUANTITY
HEAD ASSEMBLY	1
SILL ASSEMBLY	1
LEFT-HAND JAMB ASSEMBLY	1
RIGHT-HAND JAMB ASSEMBLY	1

PACK 3 DOOR HARDWARE

ITEM	QUANTITY
PIVOT SET	1
HALF OFFSET HINGE SET (WITH HANDLE)	1
INTERMEDIATE CARRIER SET	1
DROPBOLT (KEYED)	1
DROPBOLT (NON-KEYED)	1
DROPBOLT CUPS	2
DROPBOLT CUP BLANKS	2

PACK 4 HARDWARE PACK

ITEM	QUANTITY
HANDLE	1
35/35 ZINC CYLINDER	1
35 BS DOOR LOCK (3 BOLT)	1
CENTRE KEEP	1
CENTRE KEEP (BLANK)	1
HOOK KEEPS	2
HOOK KEEPS (BLANK)	2

PACK 5 FIXING PACK

ITEM	QUANTITY
WELLINGTON/OAKFOLD FIXING PACK	1

1L3R

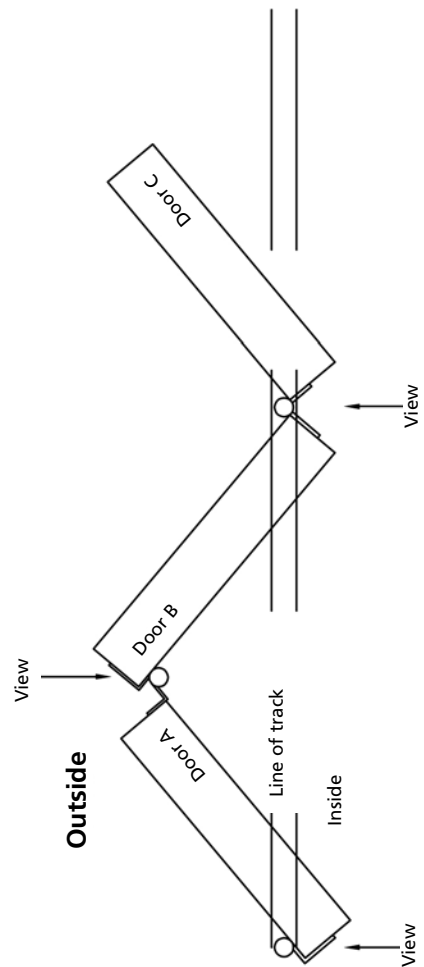
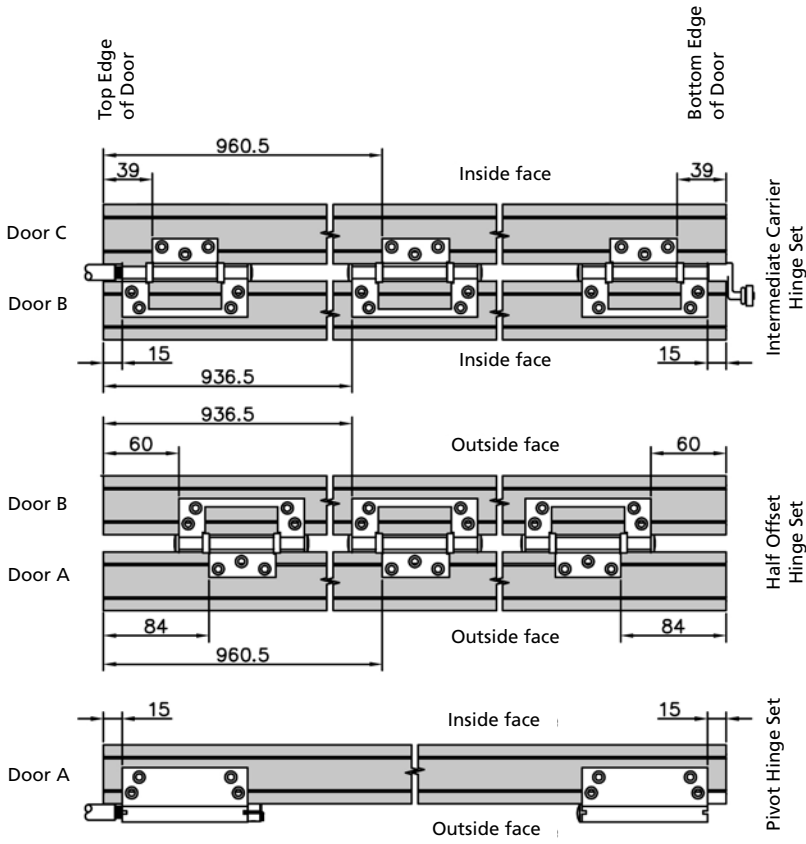
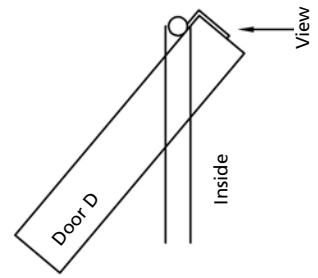
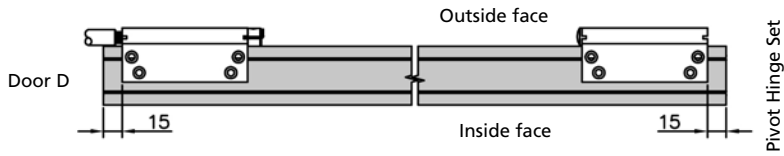

1L3R

Wellington/Oakfold Patio Doorset

Door Size: 3000mm x 2100mm

Door and Hardware Arrangement: 1L 3R

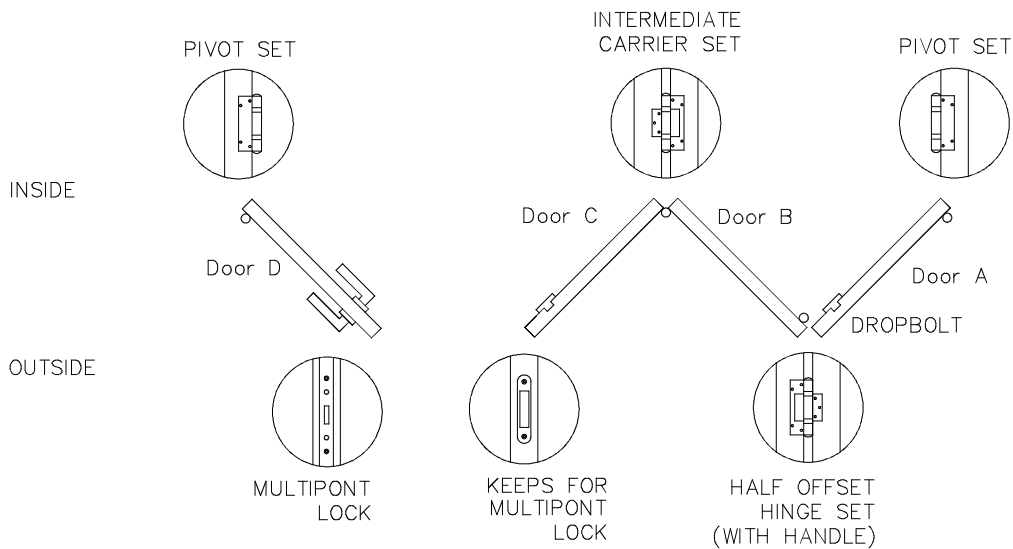

PACK 1 DOORS

ITEM	QUANTITY
Door A	1
Door B	1
Door C	1
Door D	1

PACK 2 FRAMING

ITEM	QUANTITY
HEAD ASSEMBLY	1
SILL ASSEMBLY	1
LEFT-HAND JAMB ASSEMBLY	1
RIGHT-HAND JAMB ASSEMBLY	1

PACK 3 DOOR HARDWARE

ITEM	QUANTITY
PIVOT SET	2
HALF OFFSET HINGE SET (WITH HANDLE)	1
INTERMEDIATE CARRIER SET	1
DROPBOLT (KEYED)	2
DROPBOLT (NON-KEYED)	2
DROPBOLT CUPS	4
DROPBOLT CUP BLANKS	4

PACK 4 HARDWARE PACK

ITEM	QUANTITY
HANDLE	1
35/35 ZINC CYLINDER	1
35 BS DOOR LOCK (3 BOLT)	1
CENTRE KEEP	1
CENTRE KEEP (BLANK)	1
HOOK KEEPS	2
HOOK KEEPS (BLANK)	2

PACK 5 FIXING PACK

ITEM	QUANTITY
WELLINGTON/OAKFOLD FIXING PACK	1

3L1R

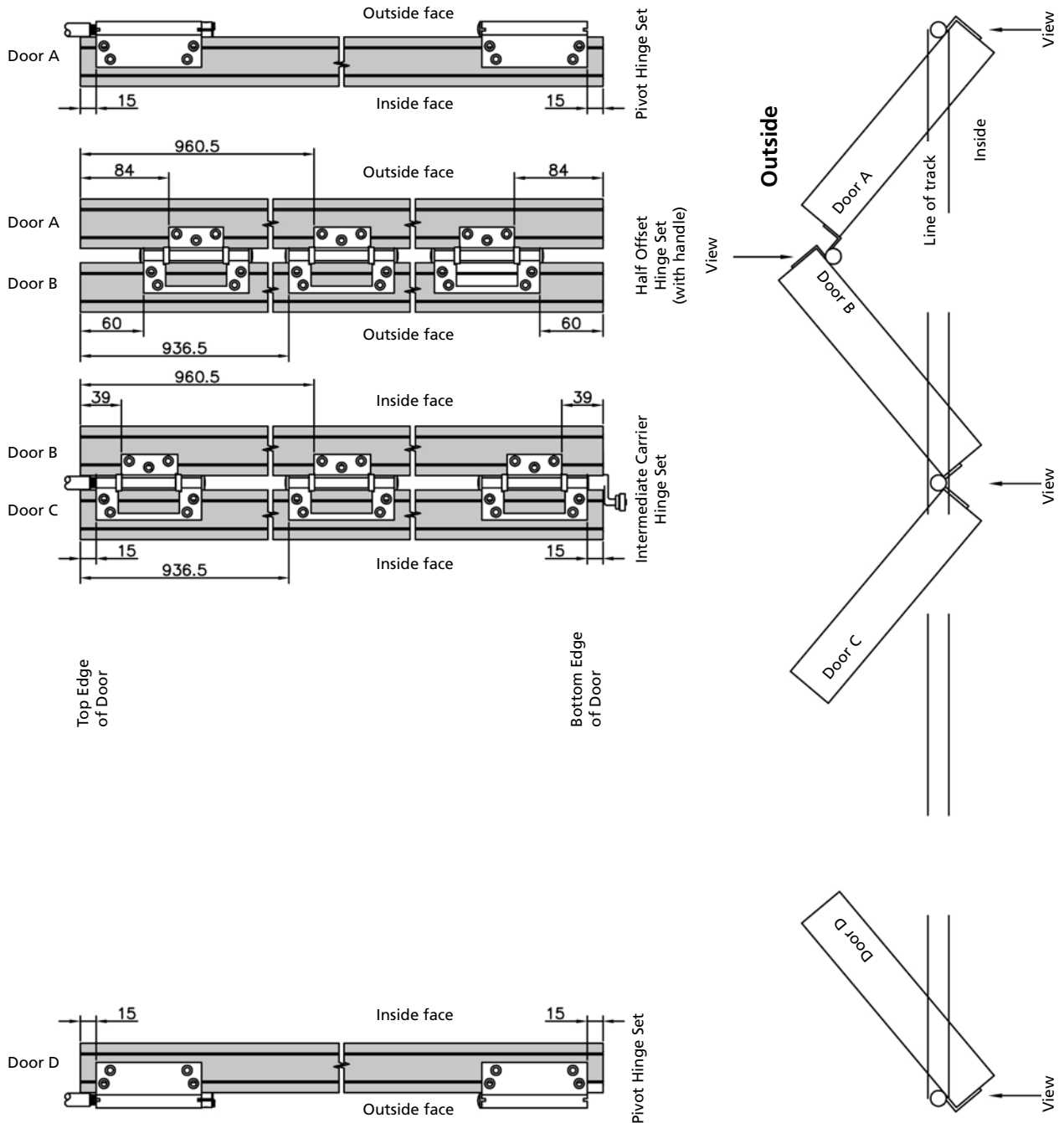

3L1R

Wellington/Oakfold Patio Doorset
 Door Size: 3000mm x 2100mm
 Door and Hardware Arrangement: 3L 1R

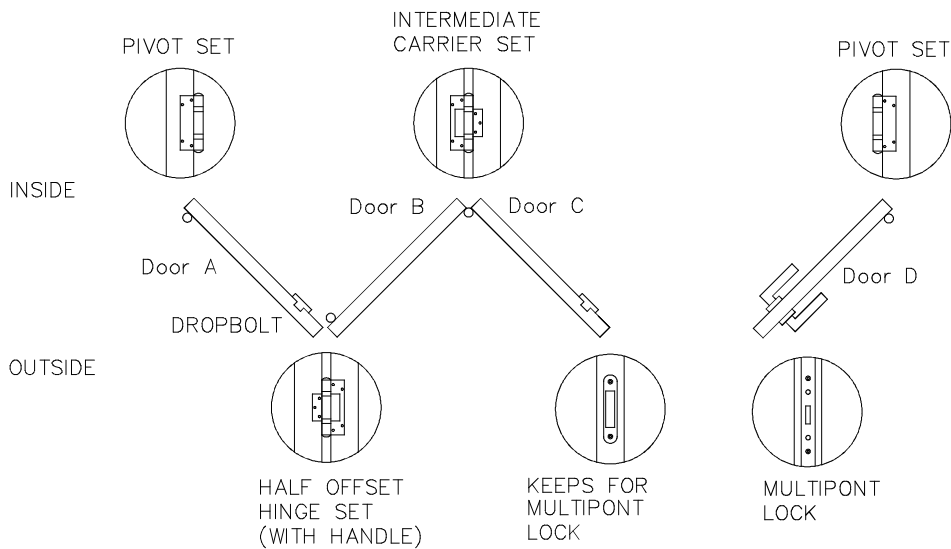

PACK 1 DOORS

ITEM	QUANTITY
Door A	1
Door B	1
Door C	1
Door D	1

PACK 2 FRAMING

ITEM	QUANTITY
HEAD ASSEMBLY	1
SILL ASSEMBLY	1
LEFT-HAND JAMB ASSEMBLY	1
RIGHT-HAND JAMB ASSEMBLY	1

PACK 3 DOOR HARDWARE

ITEM	QUANTITY
PIVOT SET	2
HALF OFFSET HINGE SET (WITH HANDLE)	1
INTERMEDIATE CARRIER SET	1
DROPBOLT (KEYED)	2
DROPBOLT (NON-KEYED)	2
DROPBOLT CUPS	4
DROPBOLT CUP BLANKS	4

PACK 4 HARDWARE PACK

ITEM	QUANTITY
HANDLE	1
35/35 ZINC CYLINDER	1
35 BS DOOR LOCK (3 BOLT)	1
CENTRE KEEP	1
CENTRE KEEP (BLANK)	1
HOOK KEEPS	2
HOOK KEEPS (BLANK)	2

PACK 5 FIXING PACK

ITEM	QUANTITY
WELLINGTON/OAKFOLD FIXING PACK	1

5L

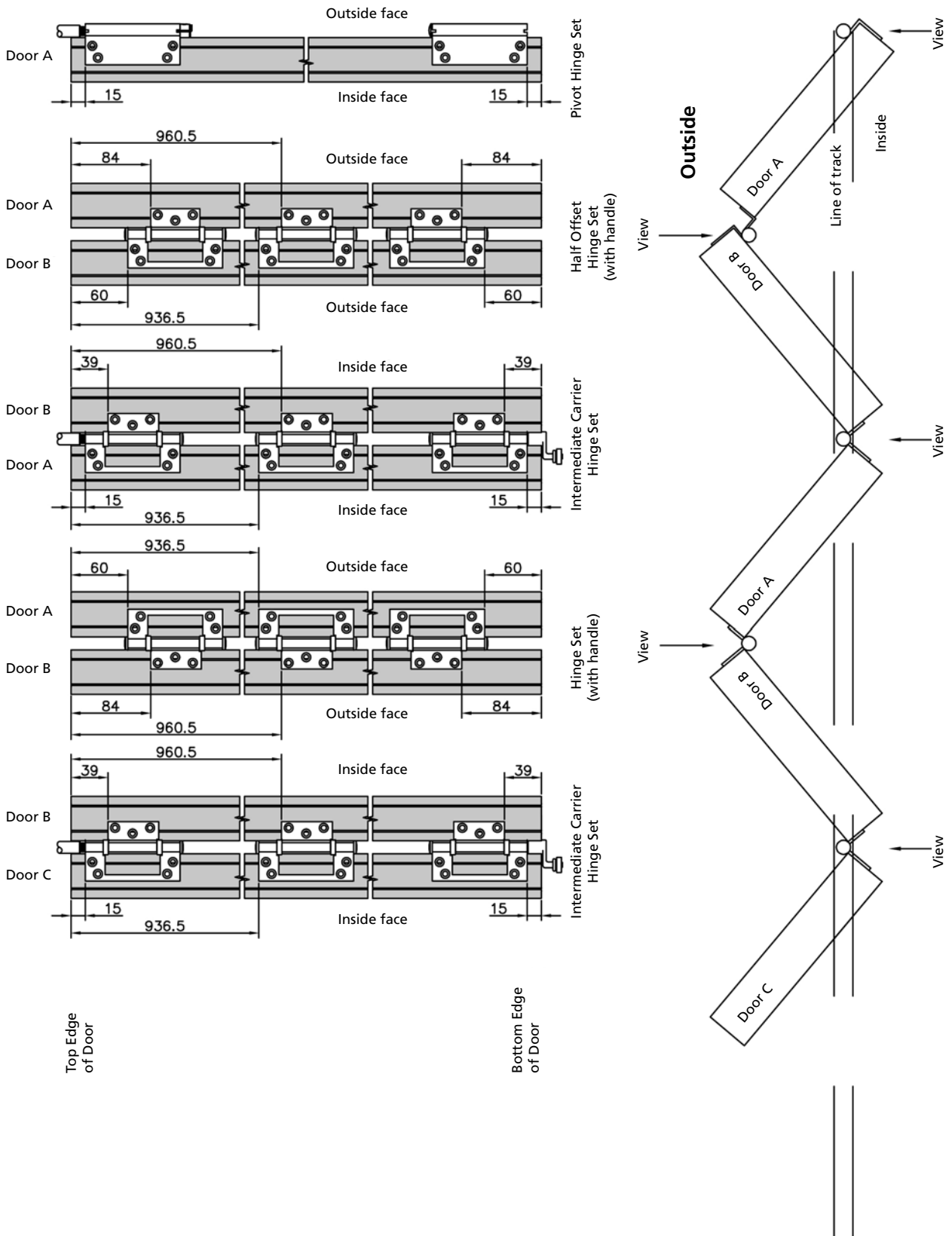

5L

Wellington/Oakfold Patio Doorset
 Door Size: 3600mm x 2100mm
 Door and Hardware Arrangement: 5L

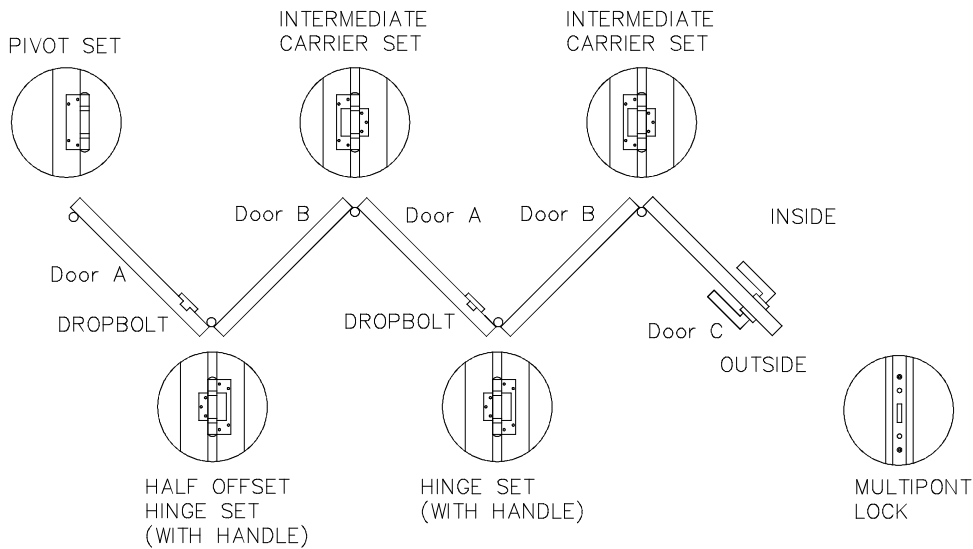

PACK 1 DOORS

ITEM	QUANTITY
Door A	2
Door B	2
Door C	1

PACK 2 FRAMING

ITEM	QUANTITY
HEAD ASSEMBLY	1
SILL ASSEMBLY	1
LEFT-HAND JAMB ASSEMBLY	1
RIGHT-HAND JAMB ASSEMBLY	1

PACK 3 DOOR HARDWARE

ITEM	QUANTITY
PIVOT SET	1
HALF OFFSET HINGE SET (WITH HANDLE)	1
INTERMEDIATE CARRIER SET	2
HINGE SET (WITH HANDLE)	1
DROPBOLT (KEYED)	2
DROPBOLT (NON-KEYED)	2
DROPBOLT CUPS	4
DROPBOLT CUP BLANKS	2

PACK 4 HARDWARE PACK

ITEM	QUANTITY
HANDLE	1
35/35 ZINC CYLINDER	1
35 BS DOOR LOCK (3 BOLT)	1
CENTRE KEEP	1
CENTRE KEEP (BLANK)	1
BOLT KEEPS	2
BOLT KEEPS (BLANK)	2

PACK 5 FIXING PACK

ITEM	QUANTITY
WELLINGTON/OAKFOLD FIXING PACK	1

5R

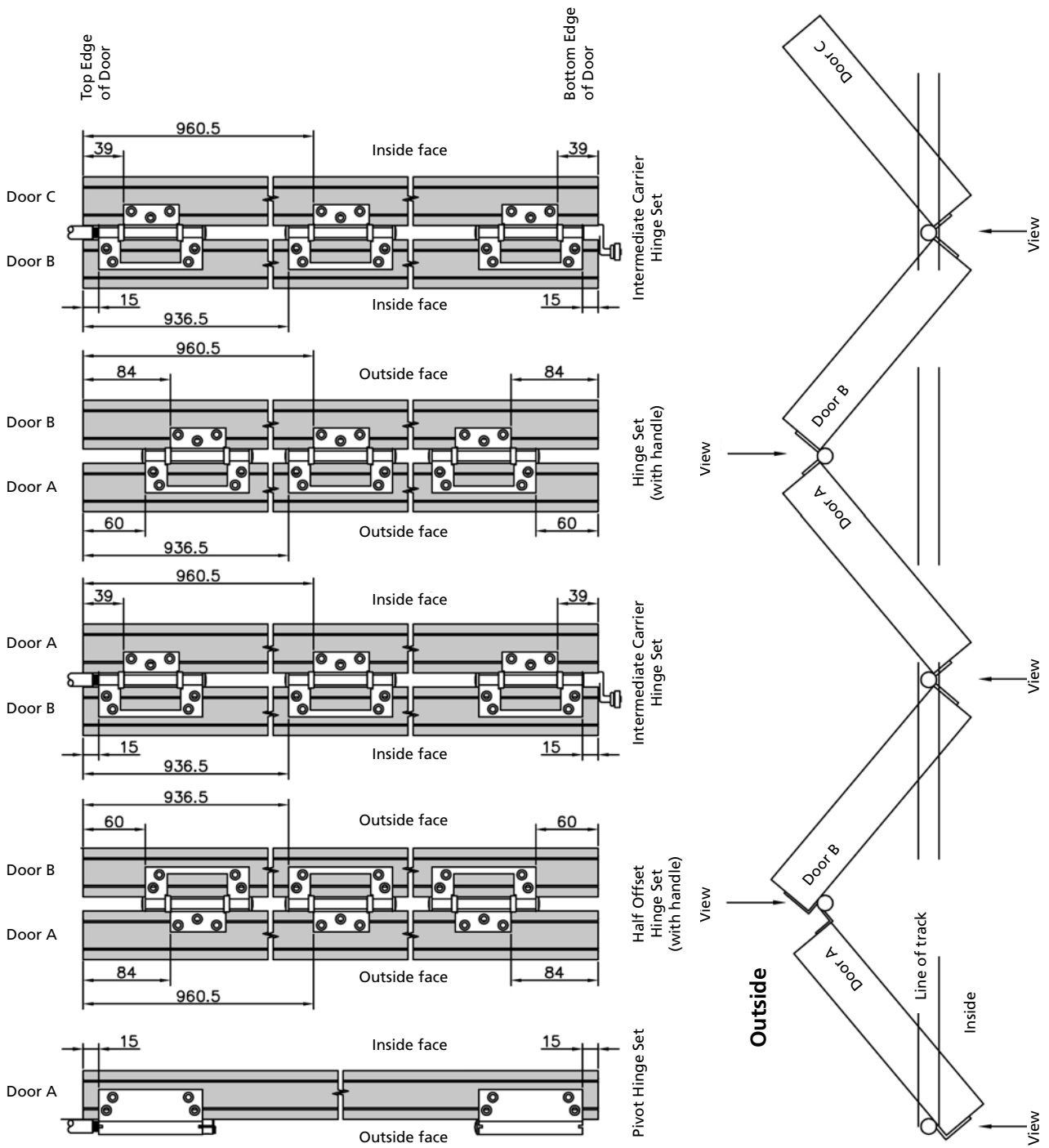

5R

Wellington/Oakfold Patio Doorset
 Door Size: 3600mm x 2100mm
 Door and Hardware Arrangement: 5R

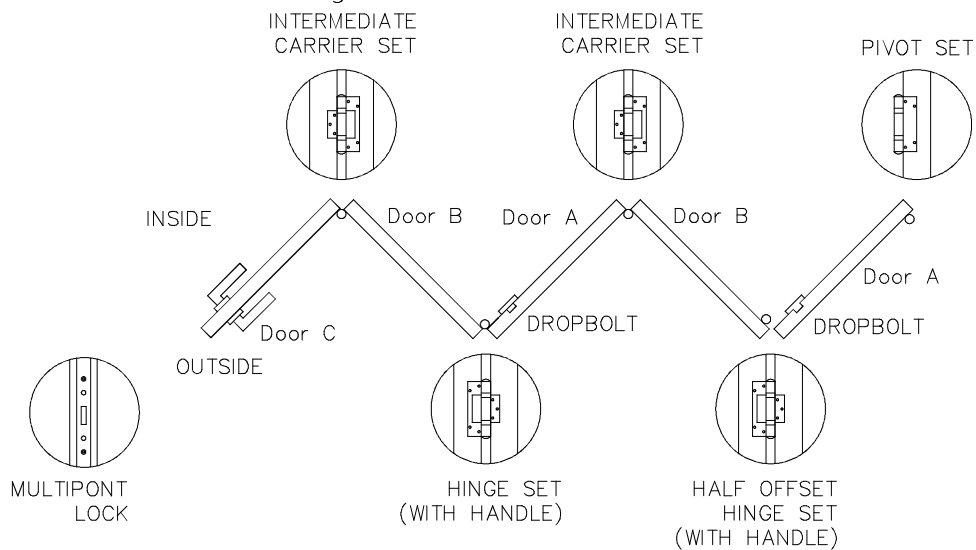

PACK 1 DOORS

ITEM	QUANTITY
Door A	2
Door B	2
Door C	1

PACK 2 FRAMING

ITEM	QUANTITY
HEAD ASSEMBLY	1
SILL ASSEMBLY	1
LEFT-HAND JAMB ASSEMBLY	1
RIGHT-HAND JAMB ASSEMBLY	1

PACK 3 DOOR HARDWARE

ITEM	QUANTITY
PIVOT SET	1
HALF OFFSET HINGE SET (WITH HANDLE)	1
INTERMEDIATE CARRIER SET	2
HINGE SET (WITH HANDLE)	1
DROPBOLT (KEYED)	2
DROPBOLT (NON-KEYED)	2
DROPBOLT CUPS	4
DROPBOLT CUP BLANKS	2

PACK 4 HARDWARE PACK

ITEM	QUANTITY
HANDLE	1
35/35 ZINC CYLINDER	1
35 BS DOOR LOCK (3 BOLT)	1
CENTRE KEEP	1
CENTRE KEEP (BLANK)	1
BOLT KEEPS	2
BOLT KEEPS (BLANK)	2

PACK 5 FIXING PACK

ITEM	QUANTITY
WELLINGTON/OAKFOLD FIXING PACK	1

5L1R

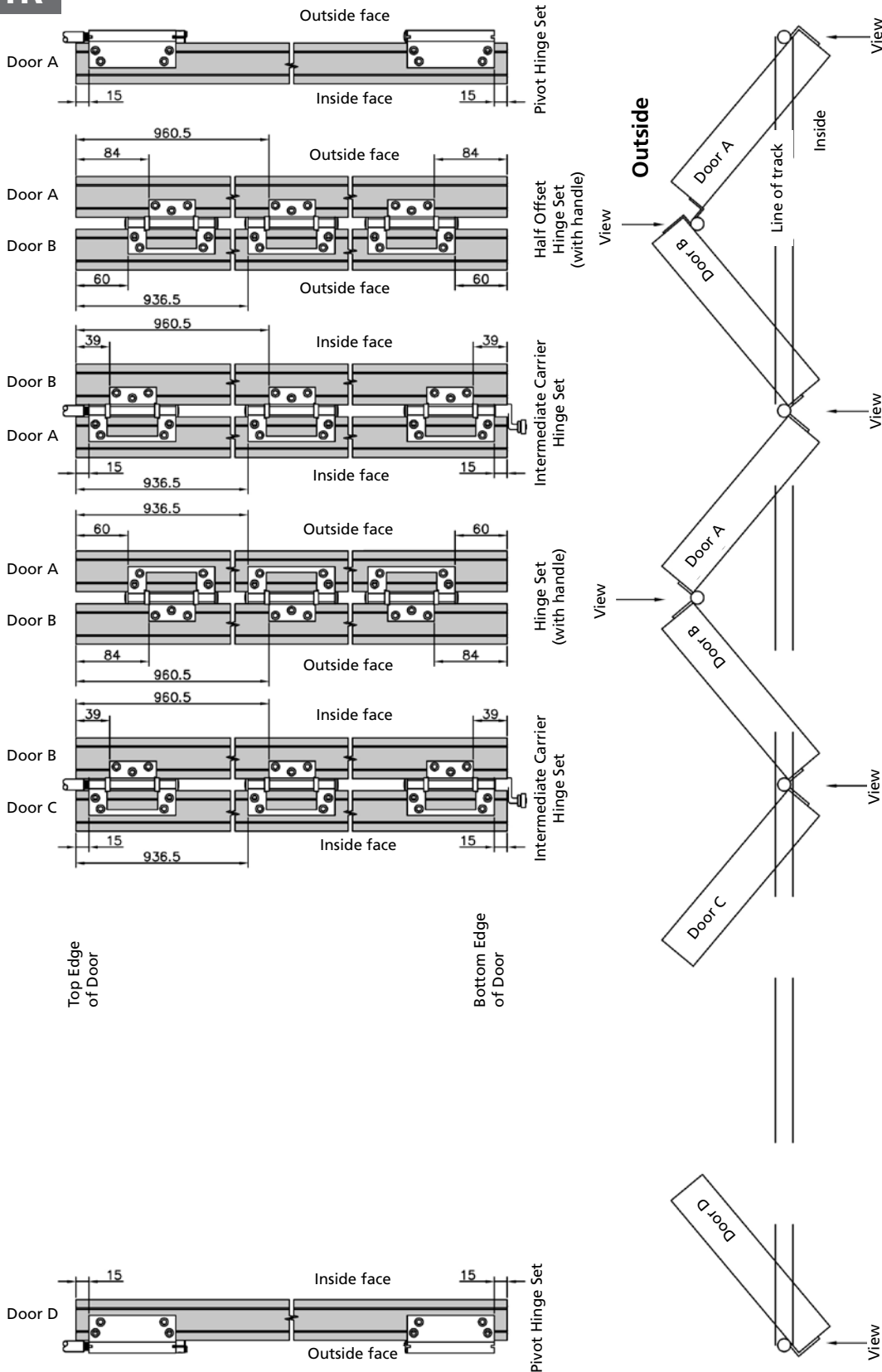

5L1R

Wellington/Oakfold Patio Doorset

Door Size: 4200mm x 2100mm

Door and Hardware Arrangement: 5L 1R

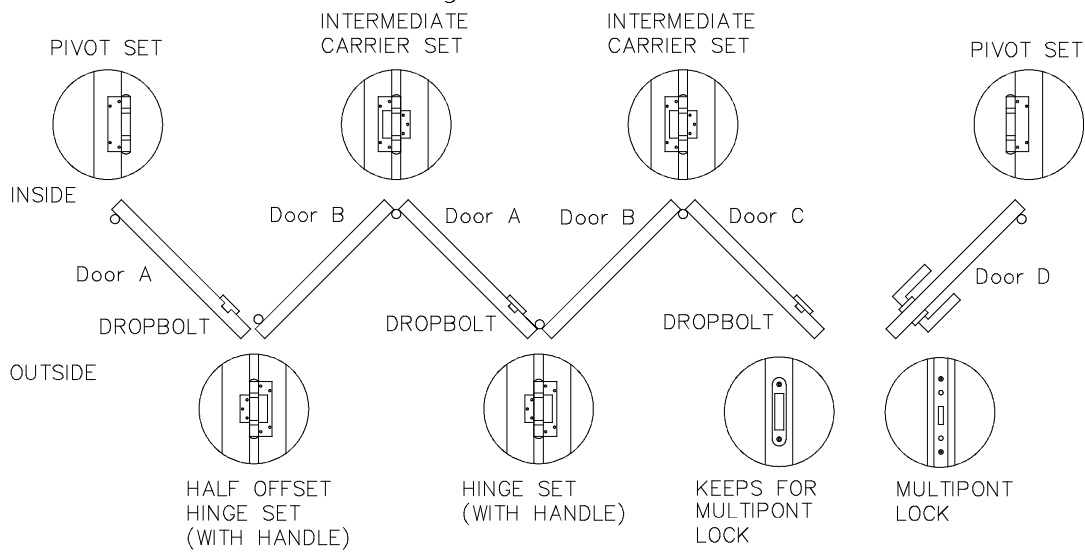

PACK 1 DOORS

ITEM	QUANTITY
Door A	2
Door B	2
Door C	1
Door D	1

PACK 2 FRAMING

ITEM	QUANTITY
HEAD ASSEMBLY	1
SILL ASSEMBLY	1
LEFT-HAND JAMB ASSEMBLY	1
RIGHT-HAND JAMB ASSEMBLY	1

PACK 3 DOOR HARDWARE

ITEM	QUANTITY
PIVOT SET	2
HINGE SET (WITH HANDLE)	1
HALF OFFSET HINGE SET (WITH HANDLE)	1
INTERMEDIATE CARRIER SET	2
DROPBOLT (KEYED)	3
DROPBOLT (NON-KEYED)	3
DROPBOLT CUPS	6
DROPBOLT CUP BLANKS	6

PACK 4 HARDWARE PACK

ITEM	QUANTITY
HANDLE	1
35/35 ZINC CYLINDER	1
35 BS DOOR LOCK (3 BOLT)	1
CENTRE KEEP	1
CENTRE KEEP (BLANK)	1
HOOK KEEPS	2
HOOK KEEPS (BLANK)	2

PACK 5 FIXING PACK

ITEM	QUANTITY
WELLINGTON/OAKFOLD FIXING PACK	1

1L5R

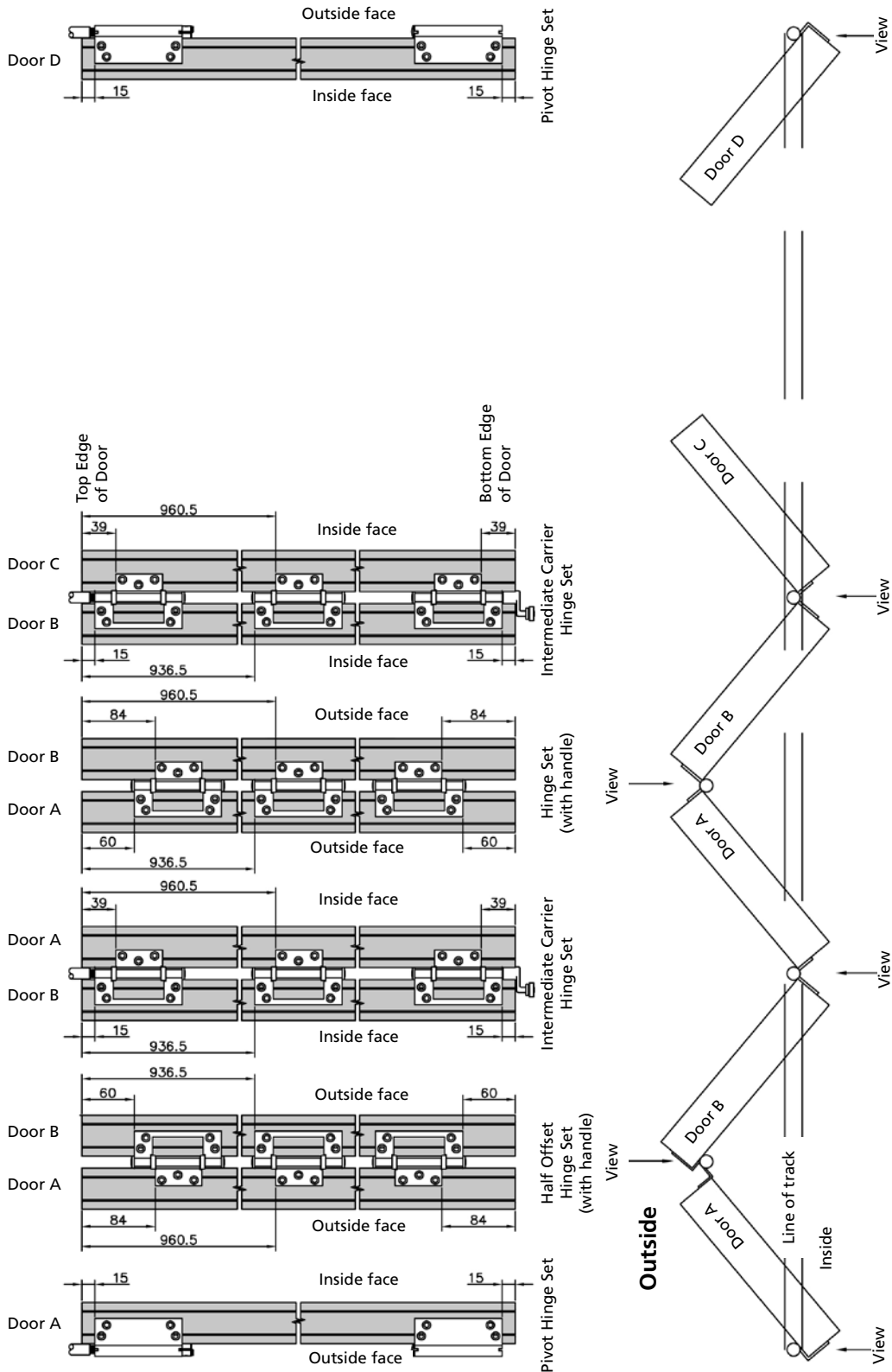

1L5R

Wellington/Oakfold Patio Doorset

Door Size: 4200mm x 2100mm

Door and Hardware Arrangement: 1L 5R

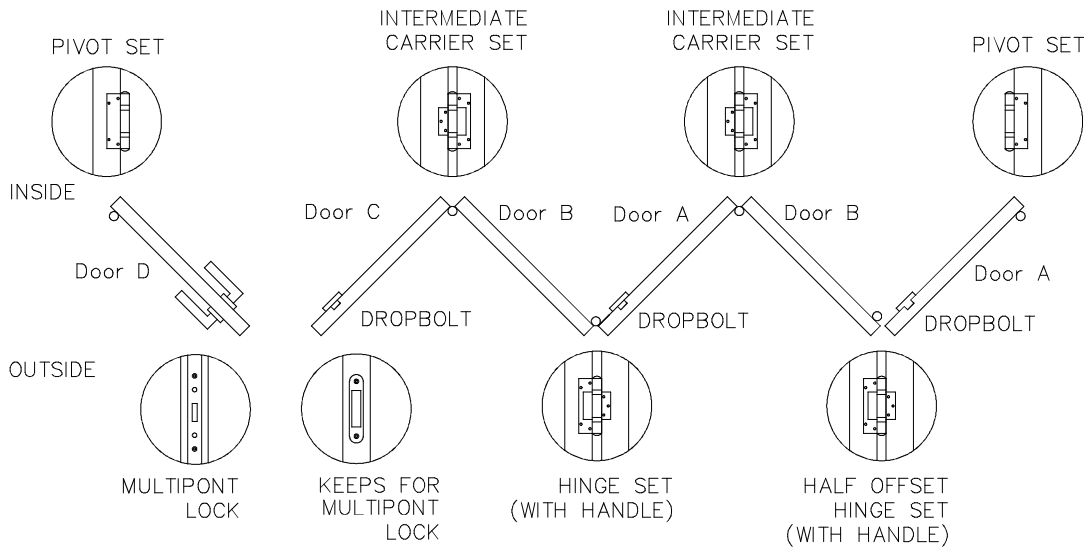

PACK 1 DOORS

ITEM	QUANTITY
Door A	2
Door B	2
Door C	1
Door D	1

PACK 2 FRAMING

ITEM	QUANTITY
HEAD ASSEMBLY	1
SILL ASSEMBLY	1
LEFT-HAND JAMB ASSEMBLY	1
RIGHT-HAND JAMB ASSEMBLY	1

PACK 3 DOOR HARDWARE

ITEM	QUANTITY
PIVOT SET	2
HINGE SET (WITH HANDLE)	1
HALF OFFSET HINGE SET (WITH HANDLE)	1
INTERMEDIATE CARRIER SET	2
DROPBOLT (KEYED)	3
DROPBOLT (NON-KEYED)	3
DROPBOLT CUPS	6
DROPBOLT CUP BLANKS	6

PACK 4 HARDWARE PACK

ITEM	QUANTITY
HANDLE	1
35/35 ZINC CYLINDER	1
35 BS DOOR LOCK (3 BOLT)	1
CENTRE KEEP	1
CENTRE KEEP (BLANK)	1
HOOK KEEPS	2
HOOK KEEPS (BLANK)	2

PACK 5 FIXING PACK

ITEM	QUANTITY
WELLINGTON/OAKFOLD FIXING PACK	1

3L3R

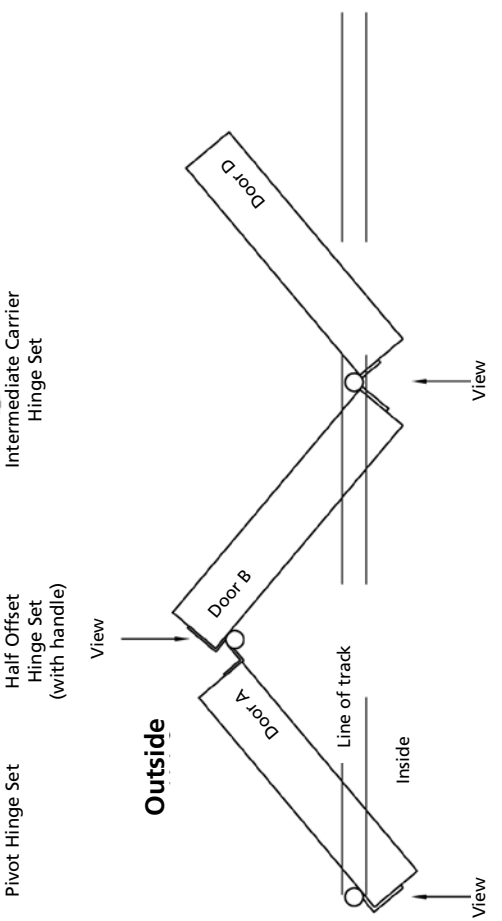
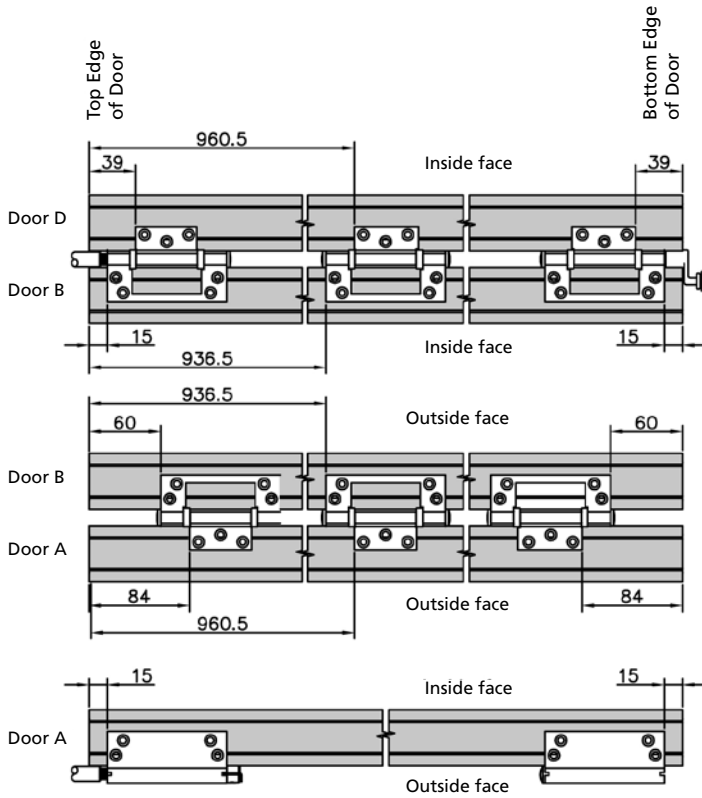
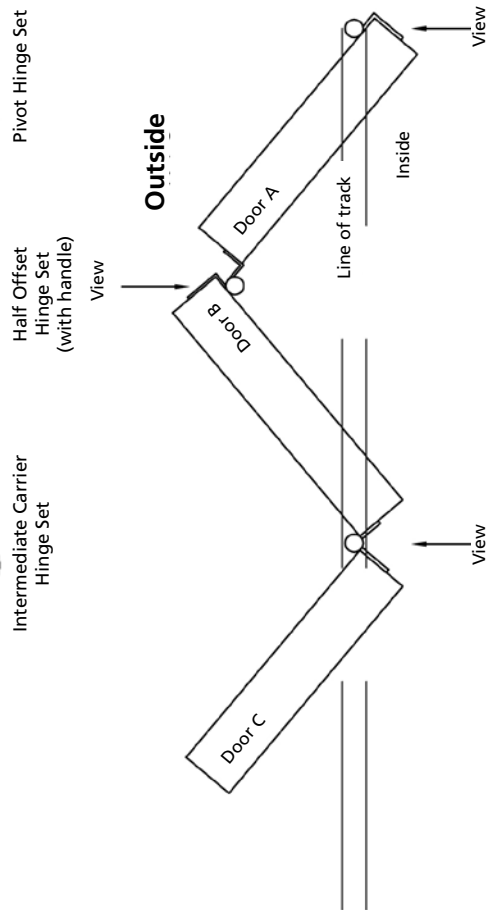
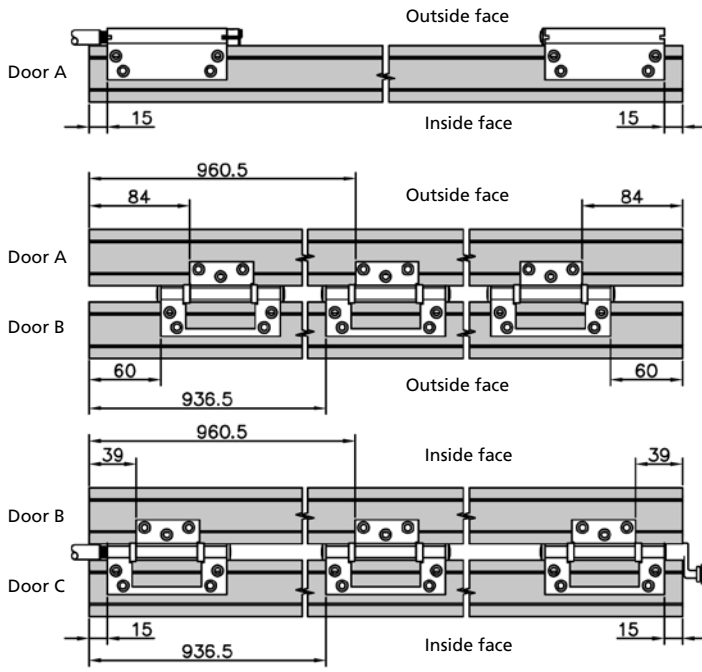

3L3R

Wellington/Oakfold Patio Doorset
 Door Size: 4200mm x 2100mm
 Door and Hardware Arrangement: 3L 3R

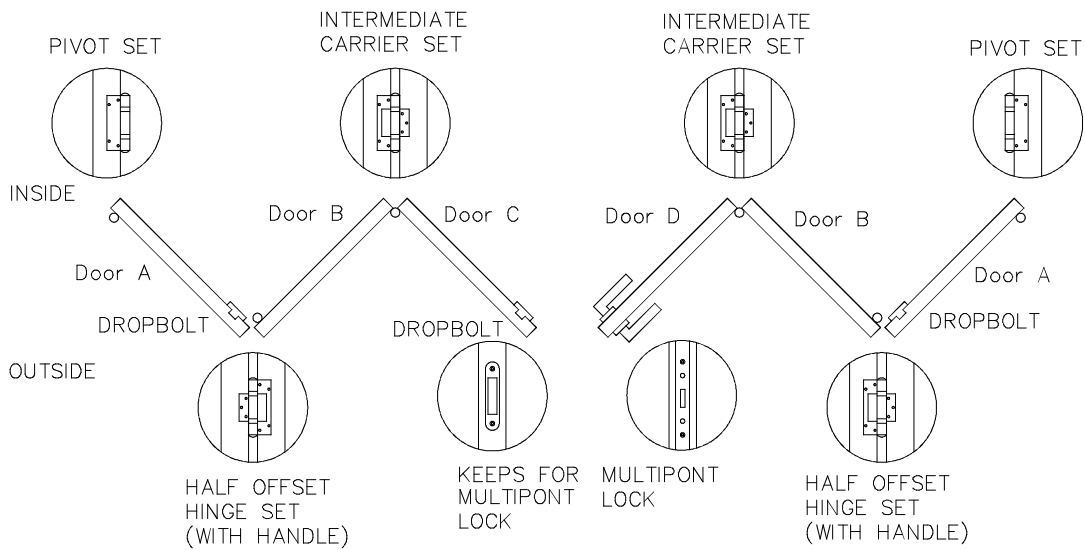

PACK 1 DOORS

ITEM	QUANTITY
Door A	2
Door B	2
Door C	1
Door D	1

PACK 2 FRAMING

ITEM	QUANTITY
HEAD ASSEMBLY	1
SILL ASSEMBLY	1
LEFT-HAND JAMB ASSEMBLY	1
RIGHT-HAND JAMB ASSEMBLY	1

PACK 3 DOOR HARDWARE

ITEM	QUANTITY
PIVOT SET	2
HALF OFFSET HINGE SET (WITH HANDLE)	2
INTERMEDIATE CARRIER SET	2
DROPBOLT (KEYED)	3
DROPBOLT (NON-KEYED)	3
DROPBOLT CUPS	6
DROPBOLT CUP BLANKS	6

PACK 4 HARDWARE PACK

ITEM	QUANTITY
HANDLE	1
35/35 ZINC CYLINDER	1
35 BS DOOR LOCK (3 BOLT)	1
CENTRE KEEP	1
CENTRE KEEP (BLANK)	1
HOOK KEEPS	2
HOOK KEEPS (BLANK)	2

PACK 5 FIXING PACK

ITEM	QUANTITY
WELLINGTON/OAKFOLD FIXING PACK	1

12 Fitting the multipoint lock

The locking door leaf is supplied morticed ready to receive the face plate of the lock.

Once you have determined the handing of the doorset, the top and bottom edges of the door leaves are established. You now need to prepare additional holes through the central mortice – shown on the diagram opposite.

Having machined the additional slots the multipoint lock can be fitted into the machined edge of the door, aligning it with the slots.

The bottom of the multi point espagnolette lock should be level/flush with the bottom of the door leaf to ensure the latch aligns.

Note: The newly machined slots should be sealed with a suitable decorative finish to protect them from moisture ingress.

Loosely fit the handles, spindle and euro cylinder to locate the lock accurately, (see Section 16) using the fixing positions in the lock face plate as a guide, pilot drill holes 3.0mm diameter x 30mm deep. Using 3.5 x 37mm woodscrews secure the lock in place.

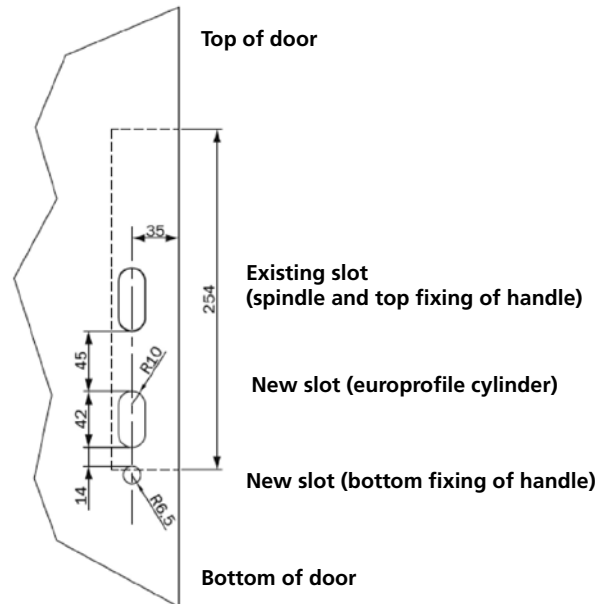

13 Fitting the carrier & pivot hinges

a) The intermediate carrier hinges should be fitted into the top track first via the cut-outs that are either located at one or both (depends on configuration supplied) ends of the top track.

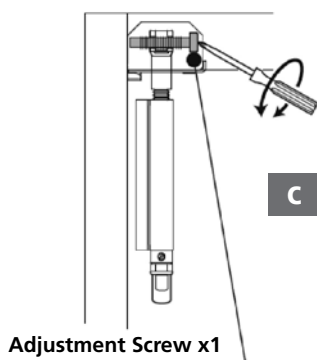
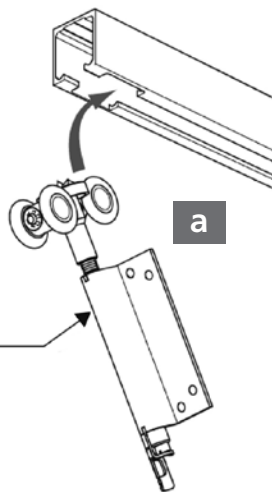

b) The top block for the pivot hinge should be fitted next, so the adjustment screw can be accessed after the doors are fitted as shown in diagram c.

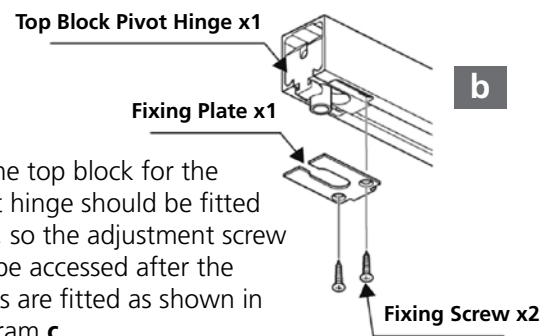

d) Adjusting of the hinges (once the doors are hung) is shown below. Do not remove the yellow plug until you are ready for final adjustment.

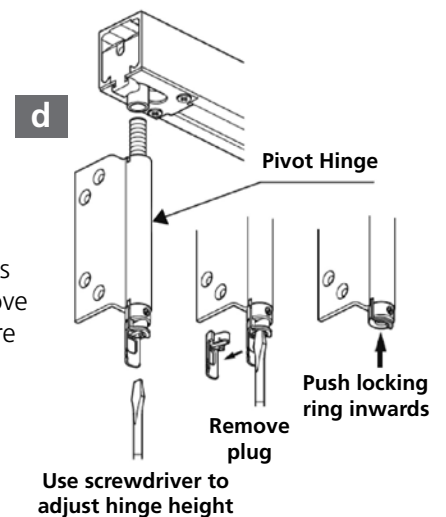

Tracks supplied with the cut out at one end only can still be handed to your requirement. Ensure you locate the carriers in the correct order. Depending on the handing you select the cut out may not be hidden.

13 Fitting the carrier & pivot hinges cont...

e) Next the bottom pivot hinge block should be fitted, again ensuring the correct orientation to allow the adjustment screw to be accessed after the doors have been hung. See diagrams e/f opposite.

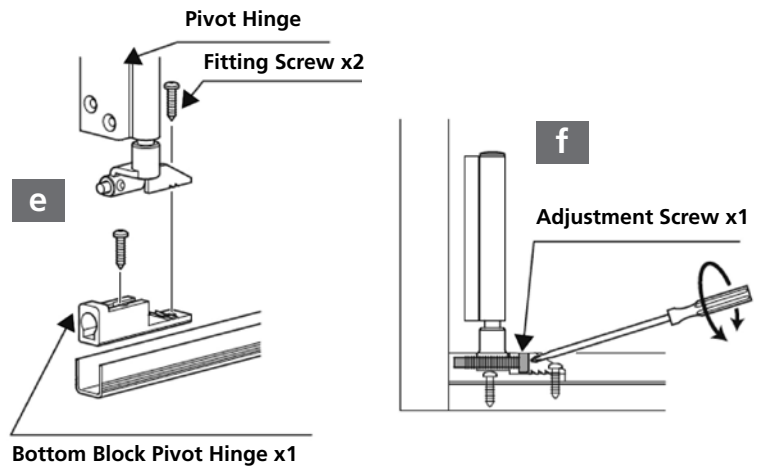

14 Hanging the doors

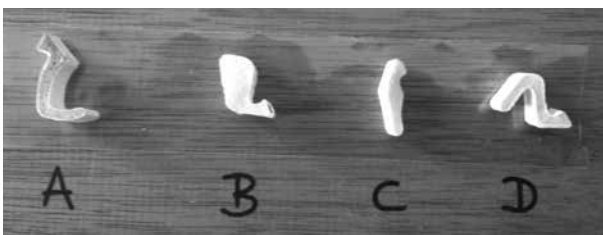

- A** = AQ5694 – pivot door seal against frame
- B** = AQ109 – between door leaves
- C** = AQ7066 – lock stile edge
- D** = AQ21 – perimeter of the frame

a) The doors should always be hung in the sequence shown in Section 11, using the relevant drawing for your configuration. Pilot drill the hinge positions using the hinge as a template. The doors should be fitted to the pivot hinge first, using the pilot holes you have prepared. The screws are contained in the sliding folding hardware box.

b) Where a hinge obstructs the weather strip, cut the weather strip around the hinge position (see diagram b). The hinges MUST not have the weather strip trapped beneath them. The seal fitted to the pivot door should be fitted in the groove adjacent to the hinges indicated (See diagram b)

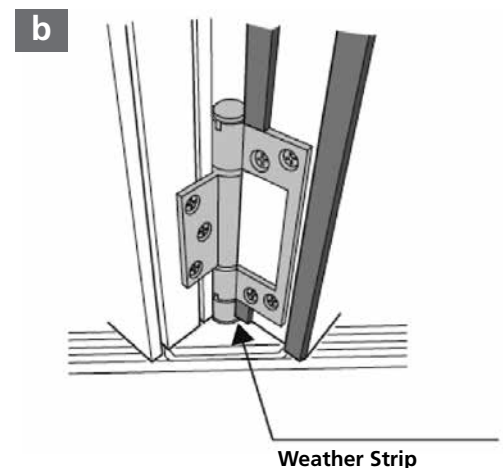
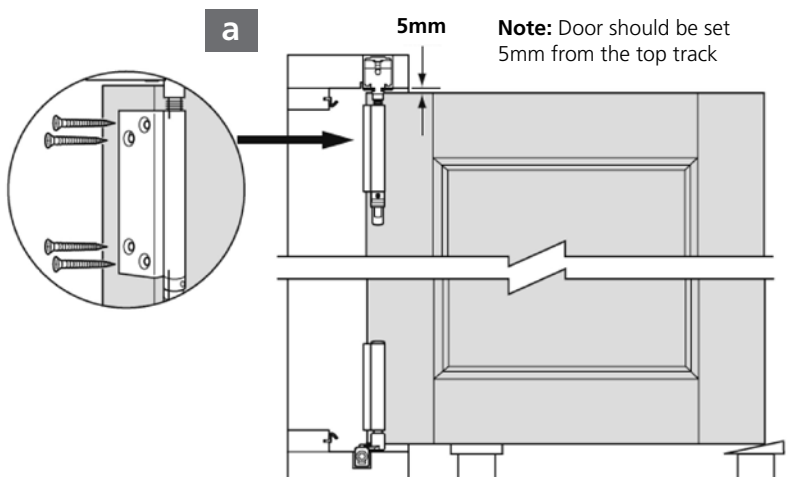

Adjust the top and bottom pivot hinges to ensure the door is vertical and set 5mm from the top track.

15 Fitting the keeps & blanking plates

To complete the frame installation fit the dropbolt cups, keeps and blanking plates in the positions shown on the door and hardware arrangement sheet. Using screws contained within the hardware pack.

Note: These doorsets are handed, use blanking plates on the jambs where necessary.

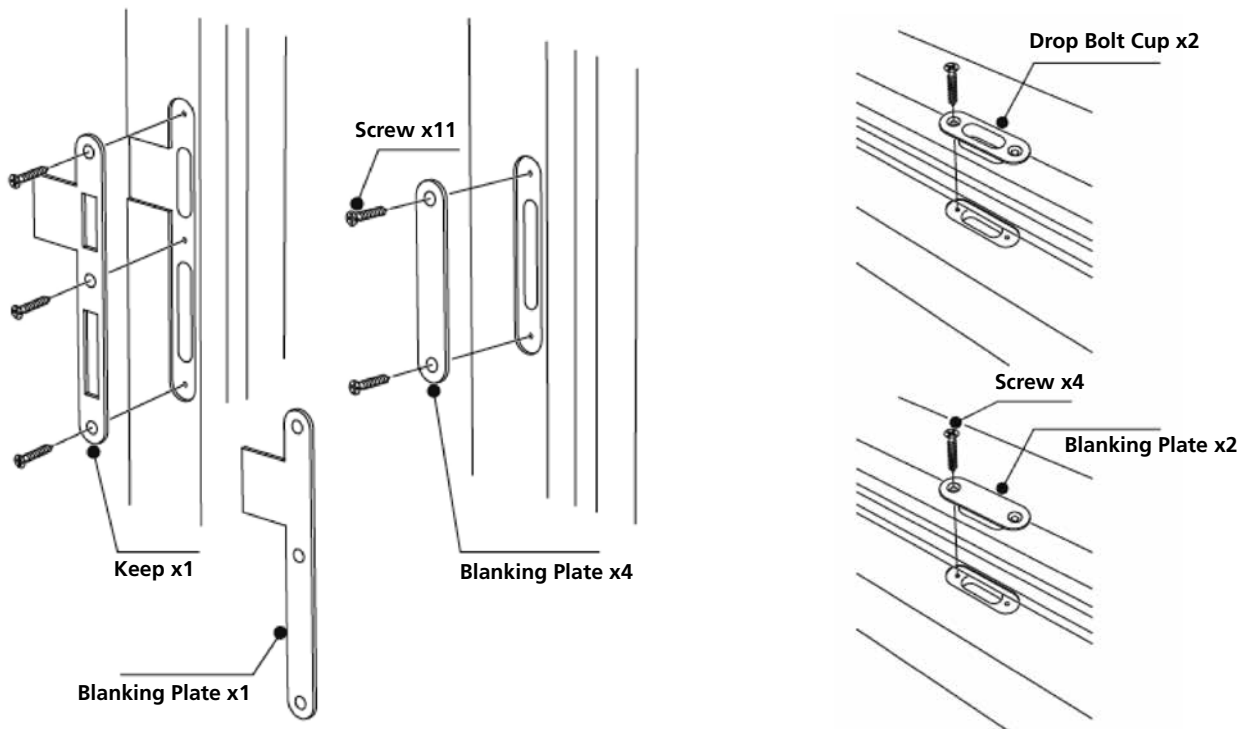

The recess for the centre keep in the door is intentionally larger than the keep in order to be reversible.

16 Fitting the handles

Note: If the lock does not operate correctly the latch may need reversing. Follow these 3 points to complete the procedure.

- Release the screw holding the latch
- Remove the latch, reverse and replace
- Refit the holding screw

Screws for handles and lock cylinder may need to be cut to the correct length.

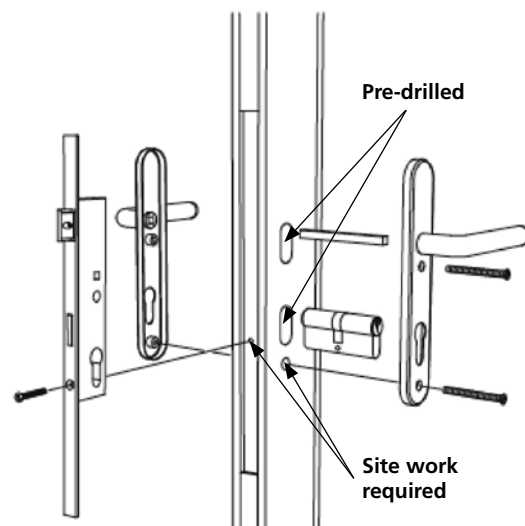

17 Adjusting the doors

The door hanging positions is altered by adjusting the top and bottom pivot hinges (see section 9) and the top intermediate carrier hinge within the headtrack (see section 9c).

Adjusting the top and bottom pivot hinges moves the door leaves sideways between the frame jambs.

Adjusting the top pivot and top intermediate hinges will raise and lower the door leaves.

Always adjust both sets of hinges evenly.

Warning: Uneven adjustment may adversely effect the operation of the doorset.

After adjustment there should be an even gap at the head, sill and jambs. The correct nominal clearance is 5mm at the head and sill, 8mm at the jambs.

Occasionally due to prevailing weather conditions movement of the timber may occur which results in greater clearances – in this situation the pivot hinges will need adjusting to allow the latch to engage correctly. This may create a gap greater than 8mm at the pivot hinge but this will be accommodated by the weather stripping at the stile and jambs.

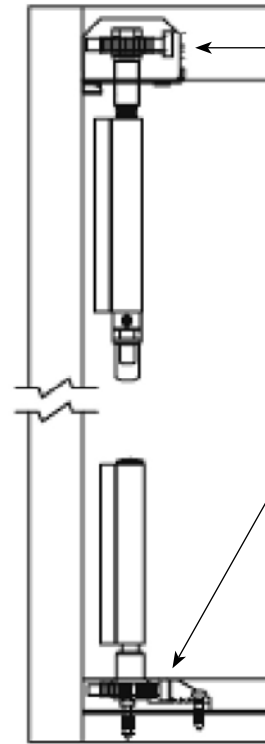

Top Adjustment Screw x1
The top and bottom pivot hinges can be adjusted to move all three doors sideways between the jambs. It is important to adjust both hinges evenly as uneven movement could effect the load supported by the head track.

Bottom Adjustment Screw x1
The top pivot hinge and the top intermediate hinge can be used to raise and lower the doors. Again, these should be adjusted together to ensure an even distribution of load.

18 Fitting the sliding bolts

There are 2 types of sliding bolts. Top Sliding Bolt and the Lower Sliding Bolt (which has the key lock).

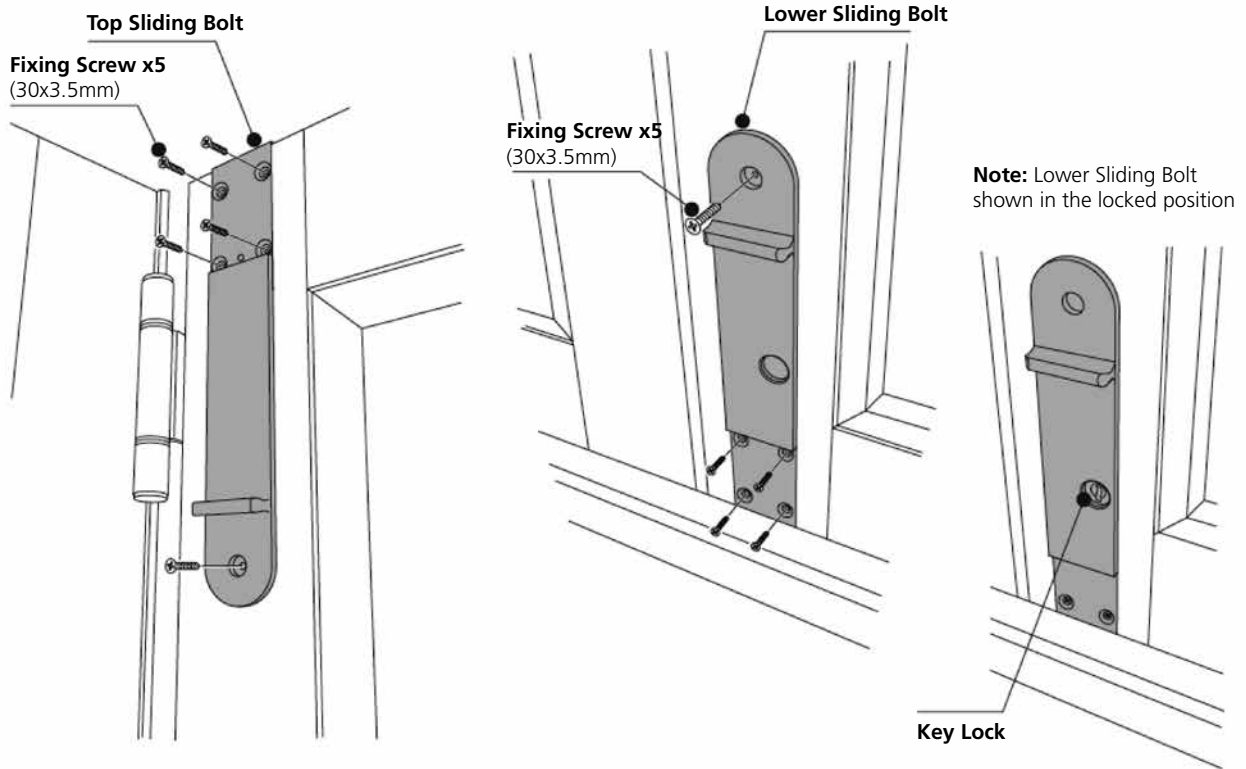

19 Fitting the ventilator

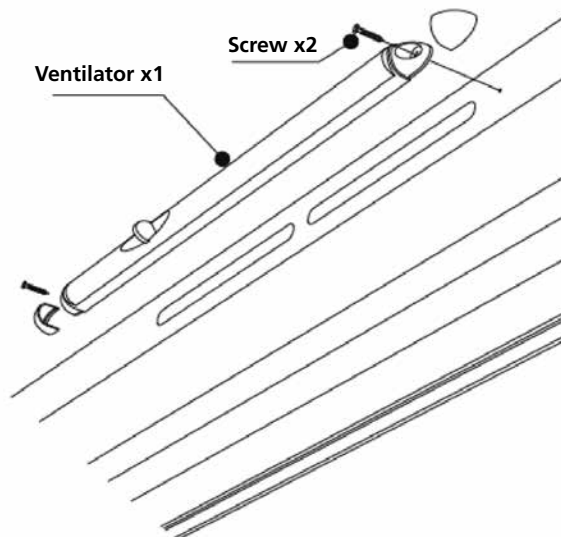

20 Finishing & maintenance

Finishing

After finishing the installation of your doorset, check that all the fixings are secure, all the specified dimensions are achieved and seals correctly fitted. This is vital for proper operation and long life of your Patio doorset.

The folding sliding doorset is supplied in;

- 1) Hardwood unfinished
- 2) Factory finished

Factory finished product requires no further decoration other than touching up damage that may have occurred during installation, The hardwood unfinished doorset must be primed or sealed immediately after delivery/ collection and **prior** to installation. This should be carried out in dry weather conditions. All faces, edges and any cut-outs should be suitably sealed immediately after un-wrapping. Before priming or sealing lightly sand off any handling marks and variations caused by exposure and ensure the surface is dust free. Unfinished hardwood can be resinous and will need to be suitably sealed prior to finishing. For paint finishes aluminium primers can provide suitable blocking properties. Micro-porous paints and medium or high build wood stains are recommended for all exterior products. The manufacturer's instructions should be followed.

Maintenance

These products must be installed in accordance with accepted good trade practice (and in accordance with supplied instructions where applicable), and maintained in accordance with these procedures or else the warranty shall be void.

Automatic Closers and Operators

All Door Hardware systems supplied are designed for manual operation only.

Hardware

Handles, hinges and bearings in buildings are subject to deterioration from everyday use, and also from environmental attack due to atmospheric and other conditions. Maintenance of hardware is even more important in severe environments such as coastal marine areas, and some industrial areas. Even stainless steel products require maintenance to prevent deterioration in some environments. JELD-WEN UK Ltd requires the following minimum maintenance to be followed otherwise the warranty shall be void.

Hinges

Wipe down the visible surfaces with warm soapy water on a soft rag and then rinse off by wiping with a clean damp rag. Application of a thin film of a light machine oil or one of the corrosion preventative sprays will help to maintain the original lustre of the metal finish. Be careful not to get these compounds on the timberwork itself as they may cause staining.

Track and Bearings

Using a spatula or similar item (not your finger), apply a small amount (typically a 1/4 teaspoon) of white petroleum jelly (Vaseline) or similar lubricant to the inner lip of each side of the top track. Ensure that the wheels pass through the lubricant and it is distributed evenly along the track. Put additional lubricant around bearings. Lubricant reduces wear, improves smoothness and further protects against corrosion of track and bearings. Remove all surface contaminants by wiping all visible track surfaces with a damp soft cloth and a mild detergent, then wipe clean with a clean cloth. In severe environments, apply a thin film of a corrosion preventative by wiping with a soft cloth moistened with one of corrosion preventative products. Stainless-steel bearings are manufactured from hardening-grade stainless steel and although this material performs considerably better than plated steels, it is still susceptible to corrosion unless maintained as described above.

Hangers, Pivots and Brackets

A light spray application of a corrosion preventative followed by a light wipe with a dry cloth to remove excess is recommended to all hangers, pivots and brackets. Exposed surfaces should first be wiped down with warm soapy water and a soft rag, and then rinsed clean before applying preventative.

Dropbolts

Spray application of a suitable lubricant to the sliding pin inside the bolt and to the lock cylinder is recommended. A tube attached to the nozzle will help to concentrate the spray where you want it to go. There are access holes or slots on all dropbolt products so that this can be done without removing the locks from the doors.

Frequency

The procedures mentioned above need to be carried out as often as is necessary to prevent deterioration in the installed environment, however we recommend the following minimum frequency of application:

- General environments 6 monthly
- Marine and industrial environments 3 monthly

Regular maintenance is required to all hardware, even stainless steel; otherwise the manufacturer's warranty may be voided.

Handles and Hardware

All hardware should be regularly cleaned using a soft cloth and mild detergent to prevent build up of pollutants such as salt etc. In maritime and industrial environments the intervals should become shorter in some instances week cleaning may be required. Harsh chemical cleaners and abrasive materials should be avoided at all times.

Leaded lights

Like any natural lead product exposed to the environment lead profile will undergo certain 'atmospheric transformation. This is perfectly natural and it will eventually settle down to take on the traditional weathered lead appearance so admired in ancient buildings. When lead first comes into contact with moisture (rainwater, condensation etc) it may result in temporary discolouration, spotting and even the appearance of white powdery deposits (basic lead carbonate) which in wet weather can run onto the glass (the glass should be cleaned during this process as the deposit can become baked on to the glass if left). Again this is perfectly natural and the temporary blemishes will eventually disappear as the natural patination process continues. Harsh marine and industrial environments may exacerbate this effect. The powder can be safely wiped off from time to time until the natural patination process is fully developed.

The time required to complete this cycle will vary depending on the purity of the lead, the location, time of year, environment, weather conditions and airborne impurities.

Glass Units

Scratches to external glass faces not reported at time of delivery and shattering caused by thermal shock are not covered under the JELD-WEN product or glass guarantees.

21 Guarantees

In keeping with our quality policy, JELD-WEN offers the following guarantees on its products. These guarantees are subject to JELD-WEN UK Terms and Conditions of Sale. Defects that are caused in whole or in part by failure to adhere to JELD-WEN UK recommendations relating to storage, handling, installation, decoration, glazing and maintenance, are not covered by the guarantees below:



Exceptional wear and tear of hardware through extreme use is not covered. JELD-WEN will accept no responsibility for products cut down in size after receipt, or when utility or structural strength is impaired in fitting or application of hardware.

Hinges, aluminium rails and other hardware fitted must never be painted, and must be kept clean and lightly lubricated at all times. Use Vaseline or neutral oil. Keep rivets and moving parts lightly lubricated. Lubricate at least once a year, in coastal areas and/or places with high pollution, clean and lubricate more often.

All joinery shall be installed correctly in accordance with normal trade practices and adequately maintained in service.

The decorative finish applied to external joinery must be maintained in service and moisture must not be allowed to penetrate into the timber throughout its life.

Regular maintenance of the paint or stain finish of the product is essential for the long-term performance of all the components of your patio doorset. The period between maintenance checks will vary depending on the type of paint or stain finish and also the local conditions for the site. External joinery products must be cleaned at a maximum of six monthly intervals using a mild non-abrasive cleaner and soft cloth. Both internal and exterior faces should be cleaned.

Make regular checks to ensure that any drainage holes, channels and spaces are kept clear. Use a soft flexible brush or pipe cleaner with care to remove obstructions.

Annual inspection should be made and touching up carried out as necessary in areas of wear and tear (for example, exposed areas of sills or where the paint film has been breached).

Hi-Build paint finished joinery is guaranteed for 5 years against blistering, cracking, flaking or erosion excluding natural resin exudation and movement around knots. Annual inspection should be made and touching up carried out as necessary in areas of wear and tear (for example, exposed areas of sills or where the paint film has been breached).

Guarantees to the finished product are also on condition that:

- No physical or chemical damage to the doorset or coating has occurred
- No repairs or alterations to the surrounding buildings have occurred which are detrimental to the joinery performance.
- No failure of the coating has occurred caused by failure of ancillary products, or glazing.
- No damage to the coatings has occurred prior to, or during, installation.
- No damage to the coating has occurred, caused by bad maintenance of the building or poor design of the building.

22 Troubleshooting guide

My door doesn't lock:

Is the cylinder correctly fitted?

Is the multi-point lock correctly positioned?

Does the lock line up with the keeps?

Refer to page 31. Fitting the multi-point lock

How do I adjust the door height or width?

Refer to page 31. Fitting the carrier and pivot hinges and page 34. Adjusting the doors

My doors don't slide/My doors drag on the sill

Check you have adjusted the height correctly

Check you have installed the frame correctly - is the sill bowed upwards? Is the head bowed down?

Check there are no obstructions in the tracks.

How often should I decorate my doors?

This will depend on the exposure environment of the location - severe industrial or maritime locations will require more frequent decoration than sheltered.

It is recommended that every six months you check the finish and wipe down all surfaces with a damp cloth.

Any signs of damage/wear to the finish will require redecoration. follow the instructions within this document

How often do I have to clean the hardware?

This will depend on the exposure environment of the location - severe industrial or maritime locations will require more frequent cleaning than sheltered. Follow the instructions within this document.

Do I need to clean the handles?

Yes build up of environmental deposits such as salt will damage the finish. A wipe down with a soft non abrasive cloth will be required, the frequency will depend on the location - maritime locations a minimum of once a month possibly more frequent.

Clashing doors - check that you have adjusted the width correctly, check you have not fitted the hinges over the weather seals.

Doors 'gapping' on seals - check adjustment

Doors 'walking back' after being fully folded - head track has not been sufficiently cambered.

Refer to page 12. Fixing the Head

Key won't turn in the lock - have you lifted the handle fully to lock? If unable to lift through the full range of movement - check adjustment and fitting of lock. Refer to page 31. Fitting the multi-point lock

Doors 'skip' when sliding back and forth - rollers are incorrectly adjusted.

Refer to page 31. Fitting the carrier and pivot hinges

