

## Warranty

This warranty is in addition to your statutory and other legal rights. Guarantee becomes effective from date of purchase or delivery, to validate and start the warranty, you must return your completed warranty registration card within 30 days. If you need any advice or if you have any questions please contact AKW Ltd.



Guaranteed for life covers all Saphini, Turico and Denova brassware against faulty material or workmanship. This excludes all serviceable parts. Not Covered by this Guarantee: Damage or defects that result from incorrect installation, improper use, accidental damage or lack of maintenance including the buildup of limescale or waterborne debris. Damage resulting from inappropriate cleaning or water freezing. Damage or defects that result from repairs, modifications undertaken by unauthorised persons who are not AKW authorised service staff or agents.



2 year Guarantee applies from date of purchase for all moving and serviceable parts against any faulty materials or poor workmanship. This is subject to normal wear and tear through usage and this does not apply to inappropriate use, damage or defects that result from unauthorised modifications or repairs, accidental damage, lack of maintenance including the buildup of limescale, waterborne debris or from water freezing damage.

AKW Guarantee will resolve defects free of charge by repairing or replacing as we may choose. To be free of charge, work must be only undertaken by AKW or our approved agents in the UK or the Republic of Ireland and with prior agreement. Any action taken under this warranty does not extend the stated 2-year expiry date.

Orderline  
01905 823299

General Enquiries  
01905 823298

Technical Help line  
01905 823242

Fax  
01905 823297

Website  
[www.akw-ltd.co.uk](http://www.akw-ltd.co.uk)

Quotes & orders email  
[orders@akw-ltd.co.uk](mailto:orders@akw-ltd.co.uk)

Enquiries email  
[sales@akw-ltd.co.uk](mailto:sales@akw-ltd.co.uk)

Post  
AKW, Pointon Way,  
Hampton Lovett,  
Droitwich Spa,  
WR9 0LR

### What to do if something goes wrong?

In the unlikely event that you should find a part missing or something goes wrong, please contact AKW Customer Services who will provide further advice and if necessary arrange for our service engineer to visit or discuss our comprehensive after-sales service. As part of our quality and training program calls may be monitored or recorded. None of the forgoing affects your statutory rights.

**Failure to install this AKW product in accordance with supplied instructions or the making of unauthorised modifications will invalidate any warranty and will affect product safety.**

## Denova Basin Taps Installation and Instructions

Guaranteed for Life  
\* see conditions, exclusions apply



Read ALL instructions carefully BEFORE installation and leave with the end user



\*23315\*

WRAS  
APPROVED  
PRODUCT



AKW  
PLATINUM

bright thinking,  
beautiful space

25 years of experience and innovative thinking giving you the ideas and support to create your perfect bathroom.

**Installation must be carried out in accordance with these instructions, and must be conducted by designated, qualified and competent personnel.**

This product must be installed in compliance with Water Bylaw Regulations. You may need to fit the optional Flow limiter to meet local requirements. Hot and cold water supply pressures should be balanced, isolating and non-return valves should be fitted. If you are unsure, please obtain the advice of a professional plumber before attempting any work.

### Water Pressure

They are fitted with single lever cartridges which provides a smooth movement.

**These taps are suitable for low and high pressure systems. Flow limiter should be used if the supply pressure exceeds 3 Bar. These taps should not be used with pressures exceeding 5 Bar.**

If the taps are installed at low pressure (tank fed), then the minimum height from the outlet of the nozzle to the underside of the cold tank should be 1.8 metres to ensure adequate performance.

These taps should be installed in compliance with Water Regulations. For further details contact your Local Water Authority.

### Installation

**Warning!** Before installation, it is essential that you thoroughly flush through the supply pipes to remove any remaining swarf, solder or other impurities. Failure to do so could cause damage to the workings of the tap. AKW will not accept responsibility for any problems that occur through incorrect installation.

1. Identify all components and check for completeness, particularly before arranging fitting.
2. Install the taps into the basin, bath or sink, using the washers and backnuts provided.
3. Connect the hot and cold water supplies.
4. Turn on the water supplies. Open both taps letting the water flow for a few minutes to flush the system.
5. Check all joints and connections for leaks. **Do not over-tighten** as this may damage the mounting surface eg, a ceramic basin.

### Maintenance

#### If the fitting begins to drip

1. Turn off the water supply.
2. Prise off cap, loosen grub screw with 2.5mm hexagon key and pull off head.
3. Remove valve.
4. Carefully clean seating, rubber washer and ceramic disc.
5. Replace valve and head and turn on the water supply.
6. Contact our helpline if problem persists.

### Exploded View/Dimensions

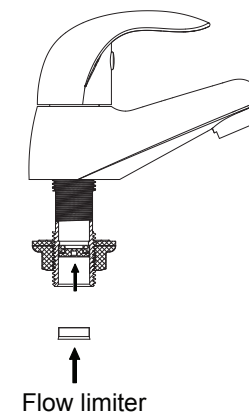
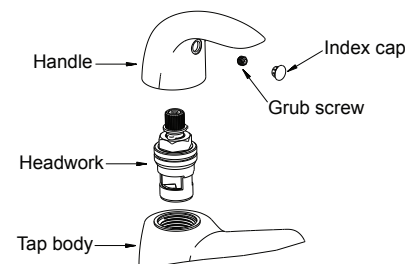
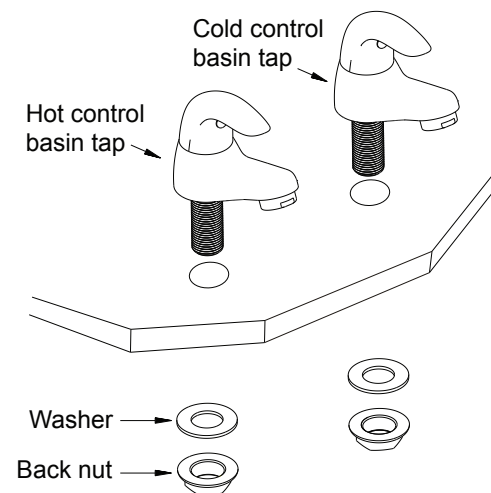
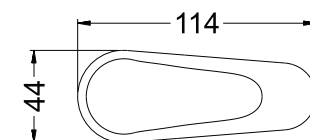
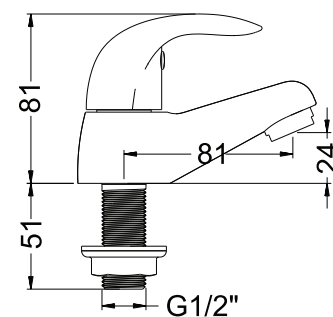

### Box Contents

Description	Qty	Description	Qty
Tap	2	Washer	2
Back nut	2	Flow Limiter	2

