

Narvello

Duo door Installation and User Care Instructions

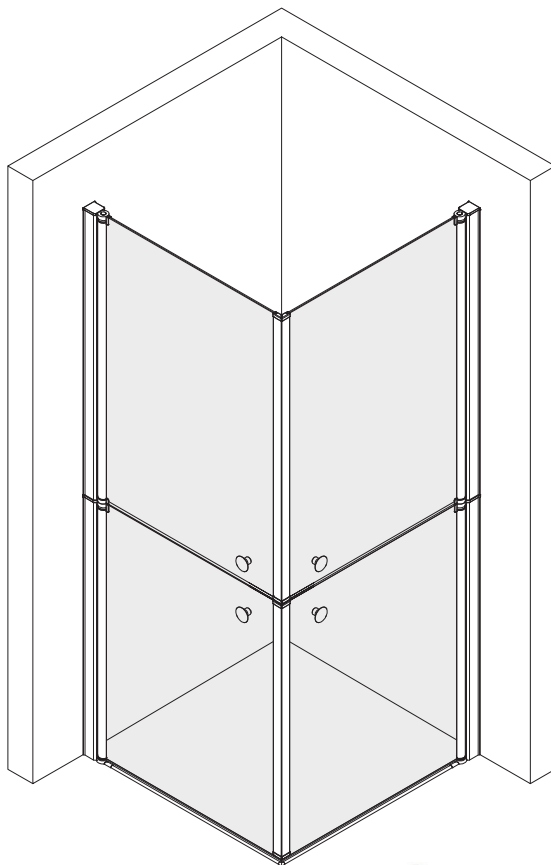

Read ALL instructions carefully BEFORE installation and leave with the end user
Important warranty information enclosed do not discard.



Suitable for Trays
& Wet Floors



BS EN ISO 9001 Cert. No. 7879
Shower and bathroom equipment



13
EN14428

Narvello

Paroi narvello Duo: Notice d'installation et d'entretien



Veillez lire attentivement TOUTES les instructions AVANT de procéder à l'installation et laissez ces dernières à disposition de l'utilisateur final

Ne jetez pas ce document, il contient des informations importantes concernant la garantie.

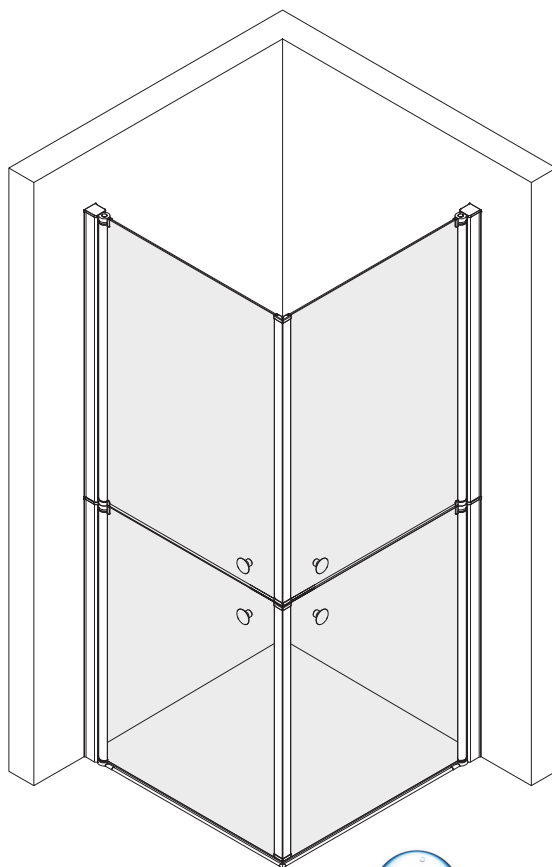

Convient pour receveurs et sol de
douche à l'italienne



13
EN14428

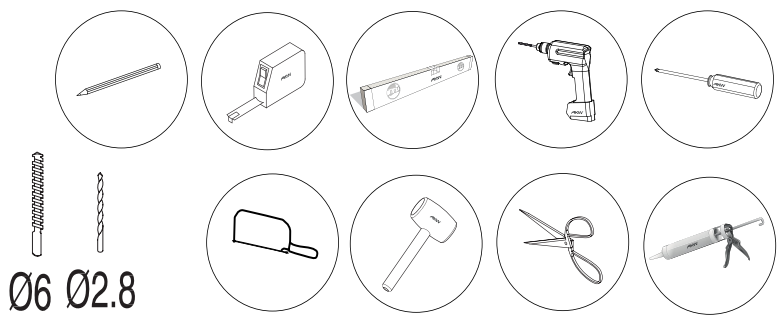
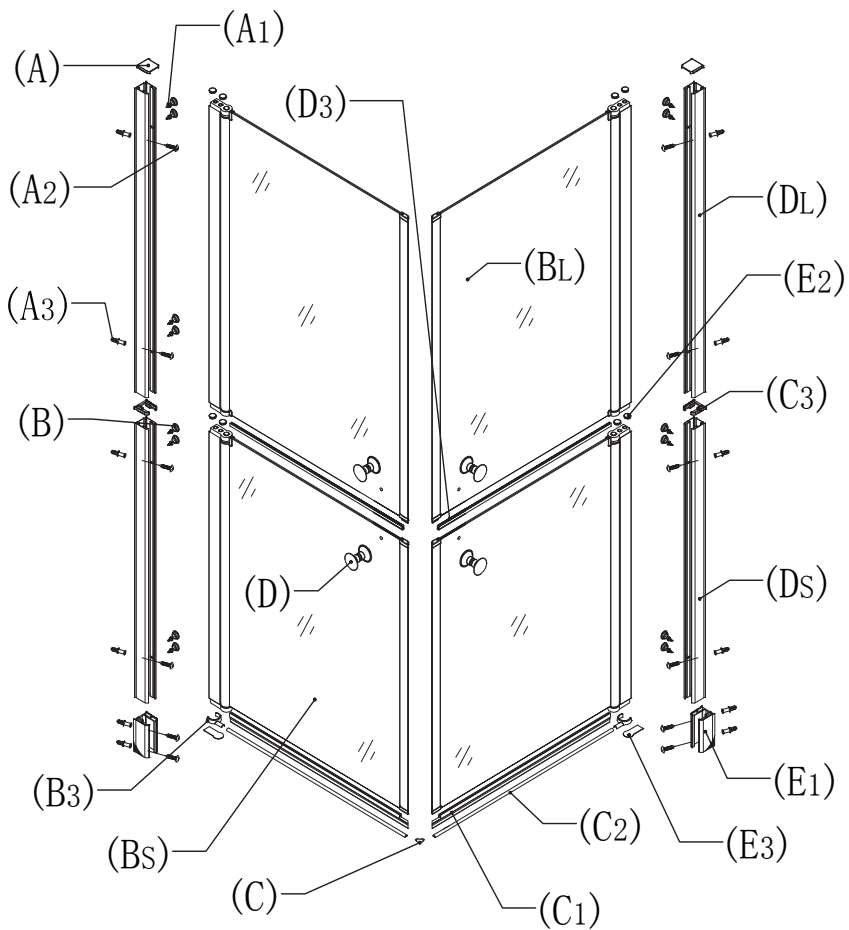

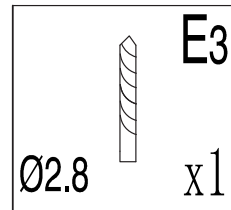
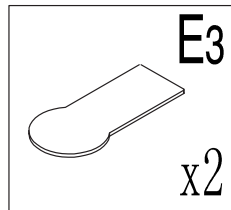
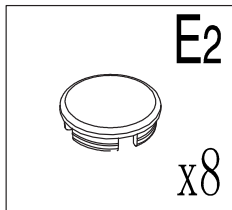
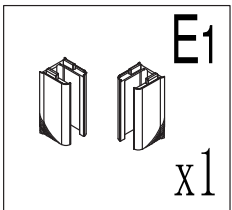
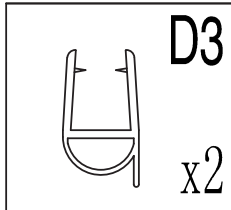
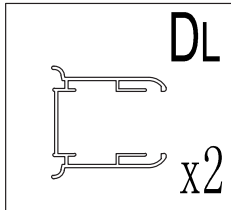
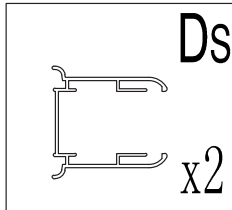
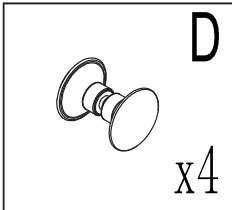
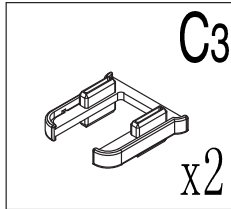
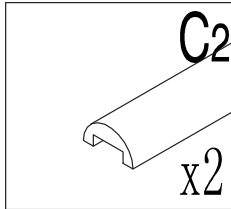
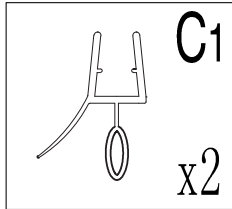
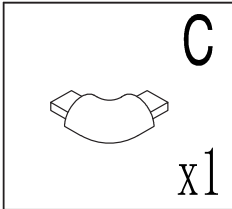
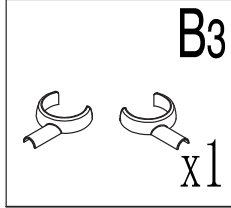
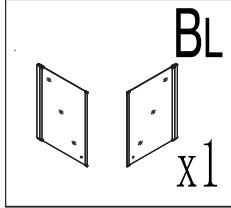
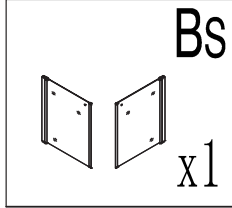
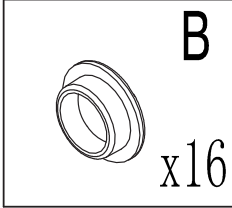
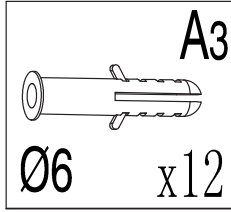
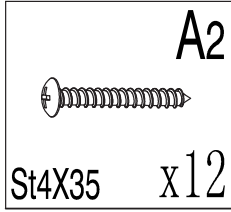
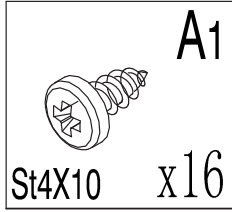
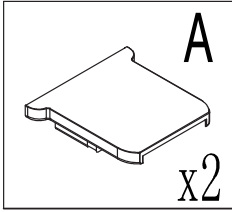

IMPORTANT NOTES :

Please read carefully and retain these instructions for future reference.

1. For ease and safety we advise that two persons assemble this product.
2. Protect shower tray surfaces at all times.
3. Check for cables, pipes etc before drilling walls.
4. Ensure all surfaces are dry, clean and free of loose debris / dust.
5. Unpack goods with care (small parts can become lodged in packaging and inadvertently discarded) Check parts supplied against parts and fittings listed herein. Damaged parts / Omissions may be resolved by calling AKW Helpline.
6. Whilst precautions are taken in manufacture, care must be taken when handling as rail ends may have sharp edges.
7. Before commencing, check:
 - a) Shower tray or wet floor is level and completely sealed to finished / tiled walls.
 - b) Finished walls are sound and free of cracks loose tiles / grout.
8. AFTER INSTALLATION, DO NOT 'WET' ENCLOSURE FOR 48 HOURS TO ENSURE FULL CURE OF SILICONE SEALANT.



HINTS & TIPS:

Surfaces to be siliconed should be de-greased in accordance with silicone suppliers instructions, observing any safety instructions.

Ensure there are no hidden pipes or cables in the wall before drilling.

If using power tools (e.g. to drill holes) wear safety glasses and always disconnect tools from the power supply after use.

If drilling holes in ceramic tiles use a piece of masking tape on the tile to stop the drill bit from slipping.

DO NOT use your drill on hammer action when drilling holes in ceramic tiles.

Use the opened out enclosure packaging to protect your floor and wall while assembling.

To check spirit level accuracy place on a horizontal surface. Note the bubble position between markers. Rotate the spirit level through 180 Degrees horizontally then note the bubble position. Check both noted positions match each other. If they do not match recalibrate or renew the spirit level. Repeat the test also in the vertical plane.

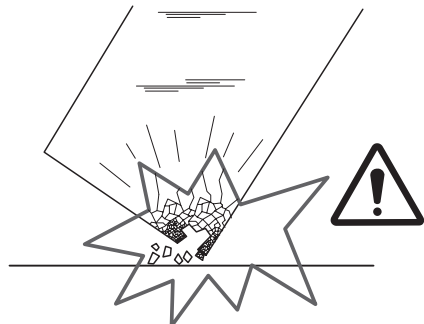
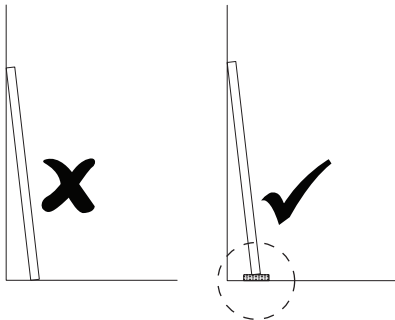
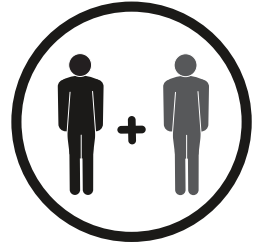
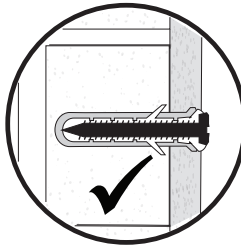
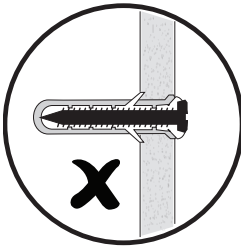
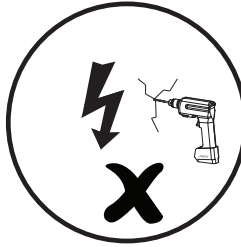
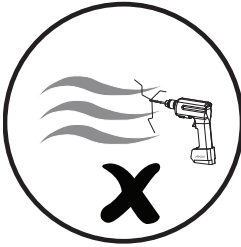

1

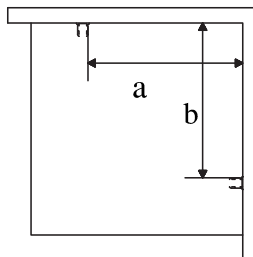

	a	b
800x800	740x760	740x760
900x900	840x860	840x860
1000x1000	940x960	940x960

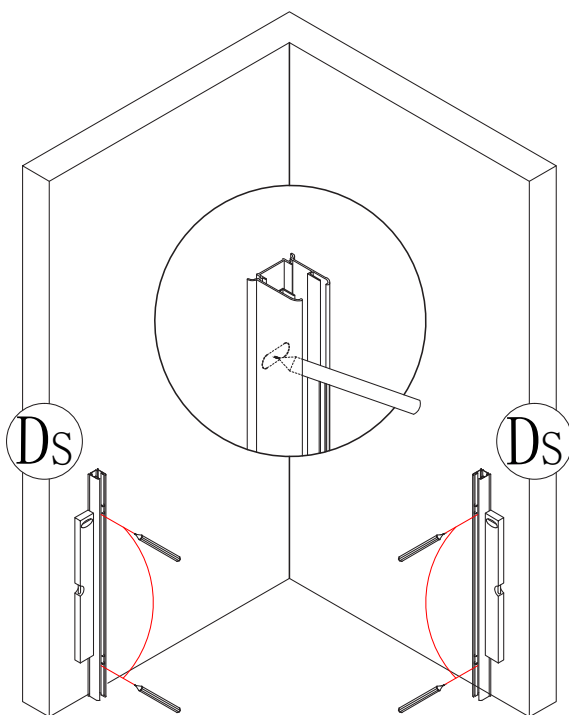

2

Wet Floor
Sol Mouillé
Nassen Boden

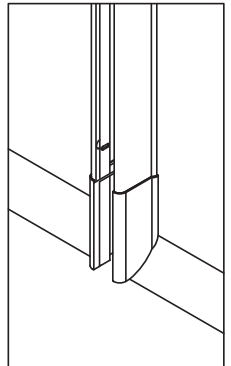
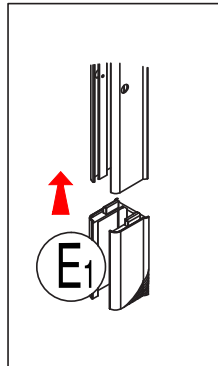
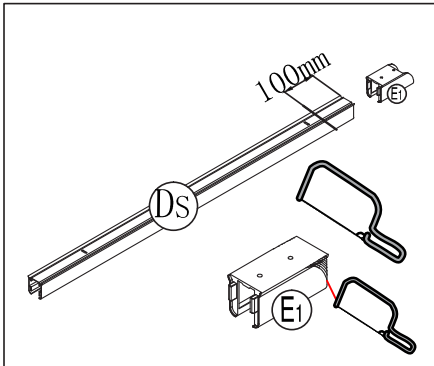
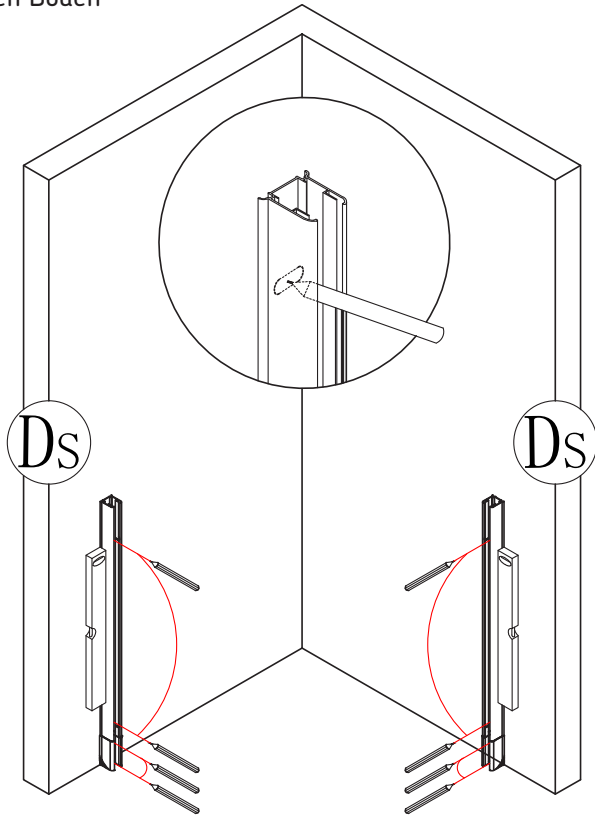

3

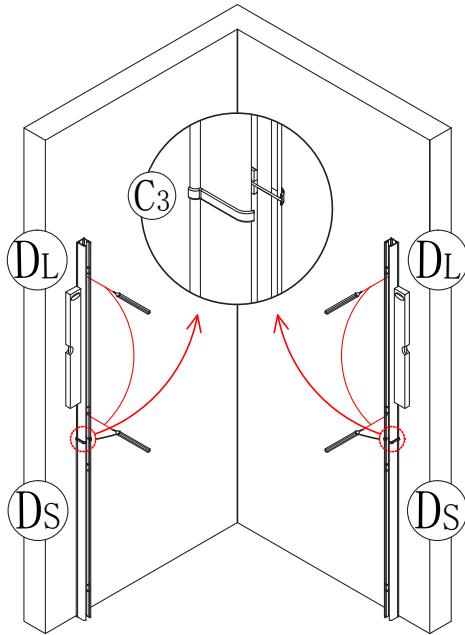

On Tray
Le Plateau
auf Tablett

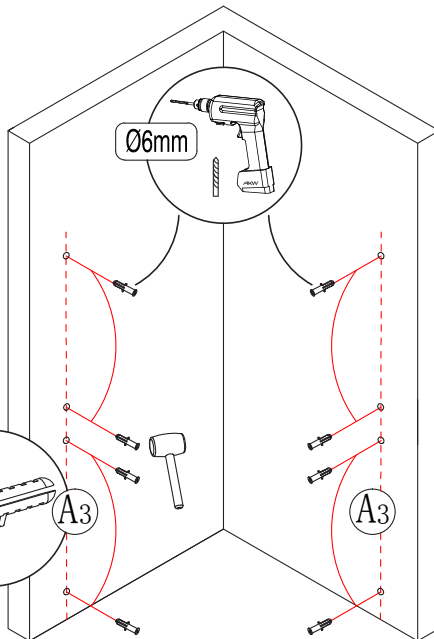
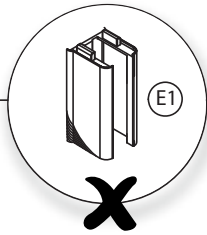

4

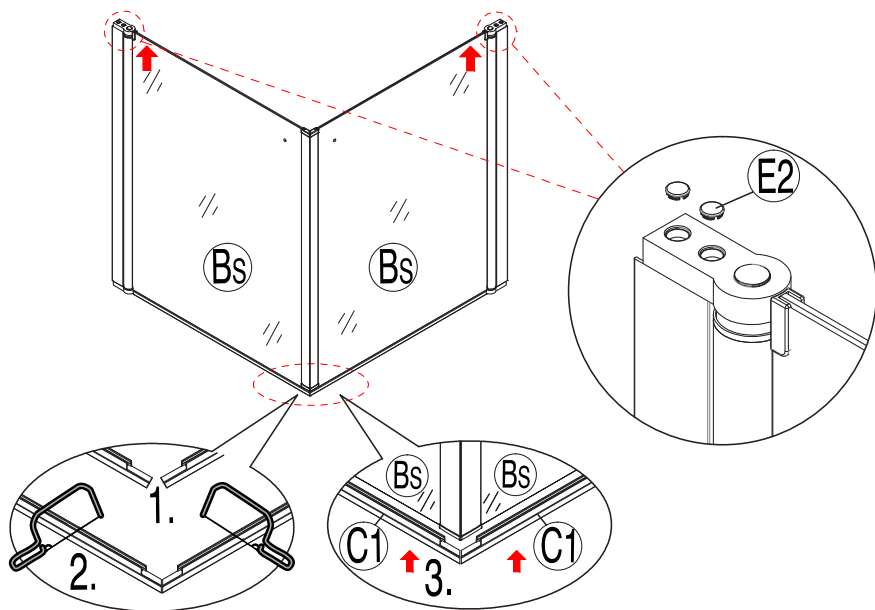
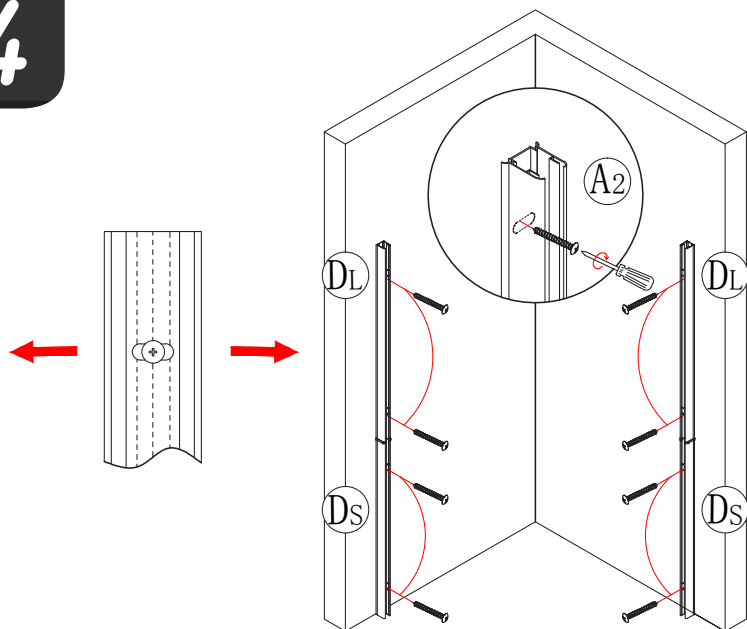

5

2.

1.

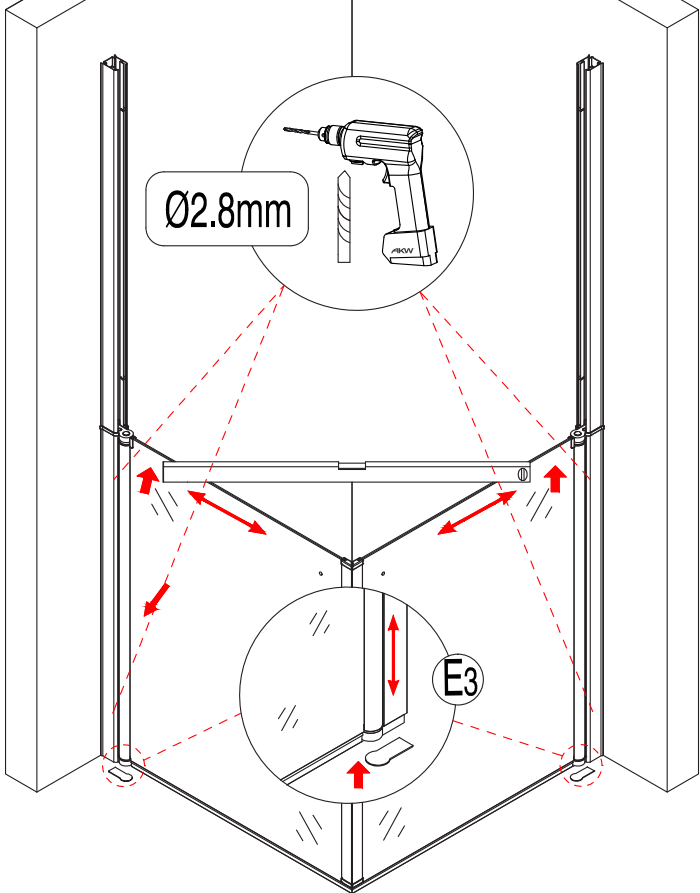
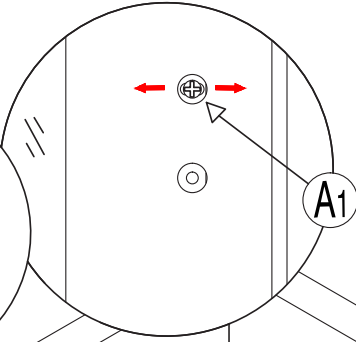
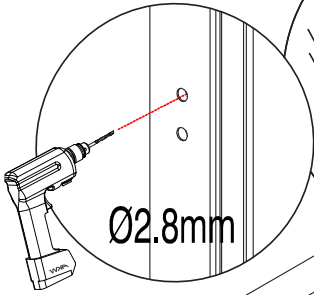

6

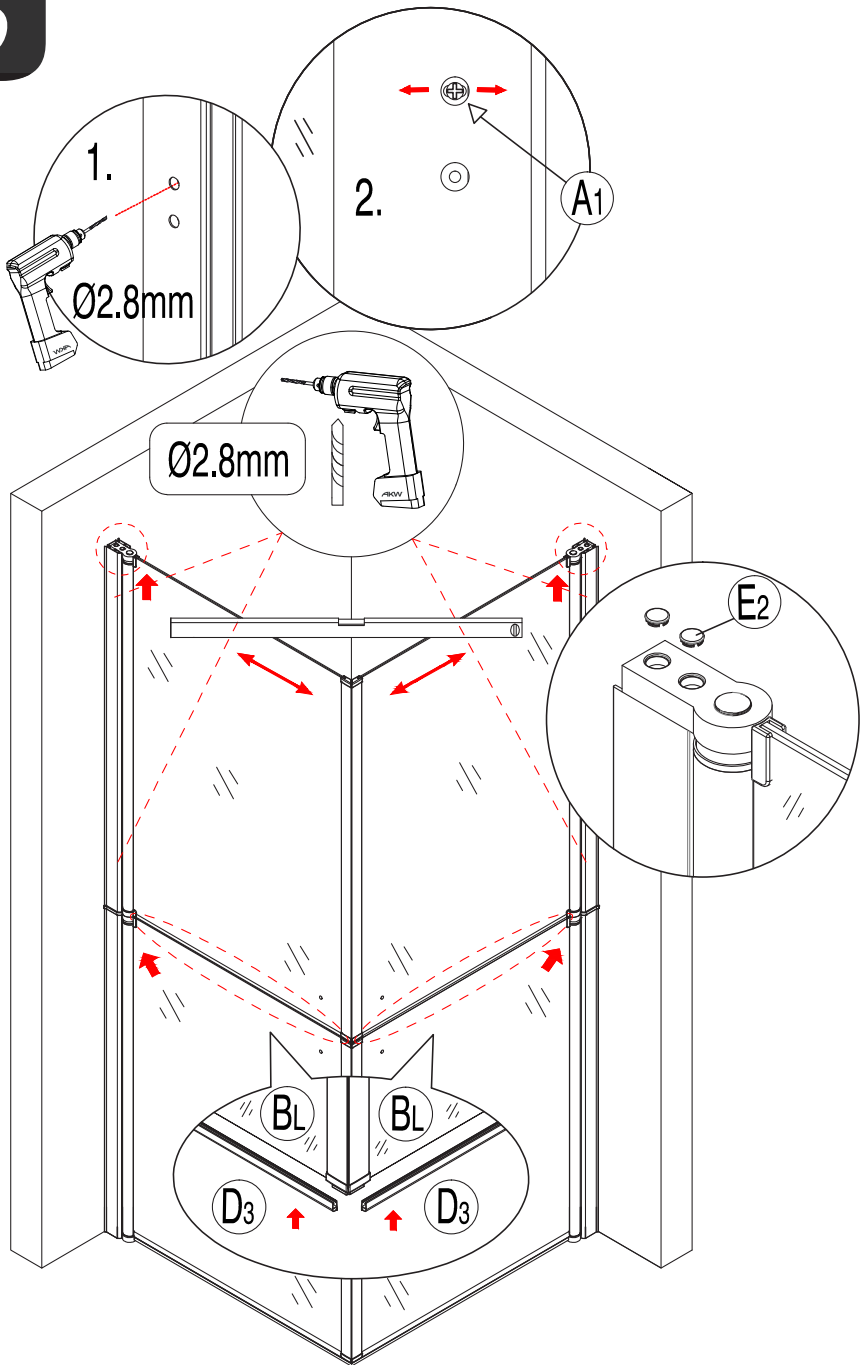

7

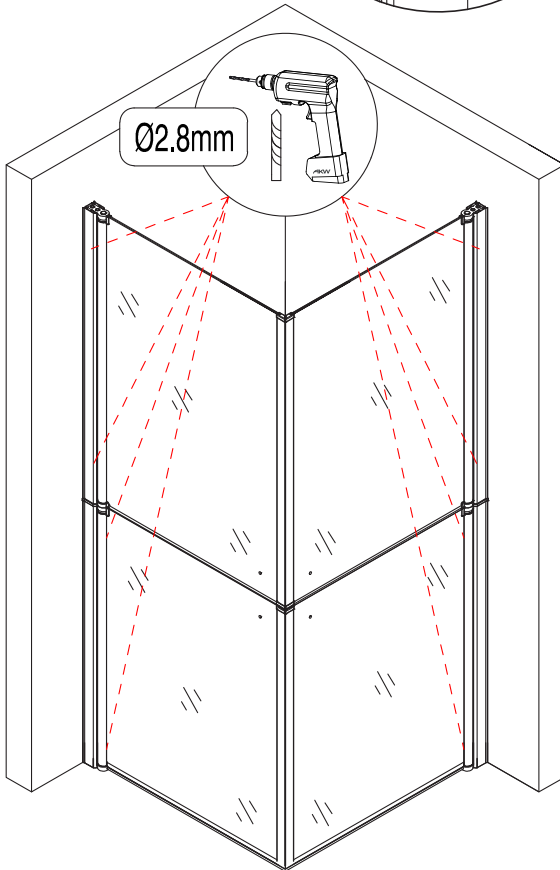
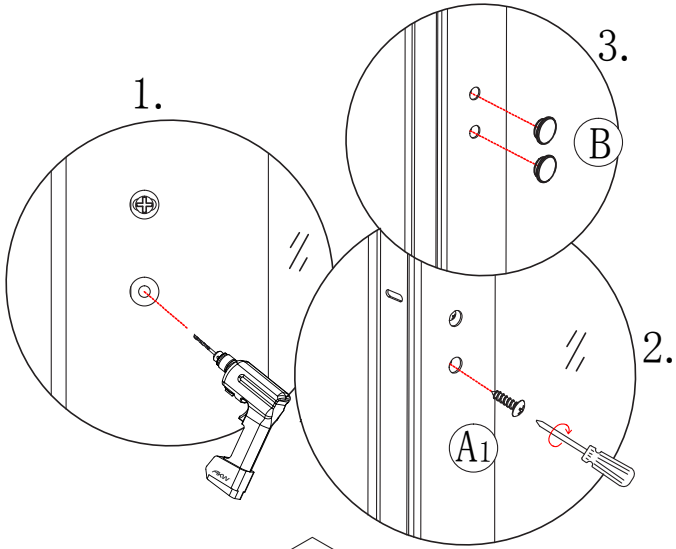

8

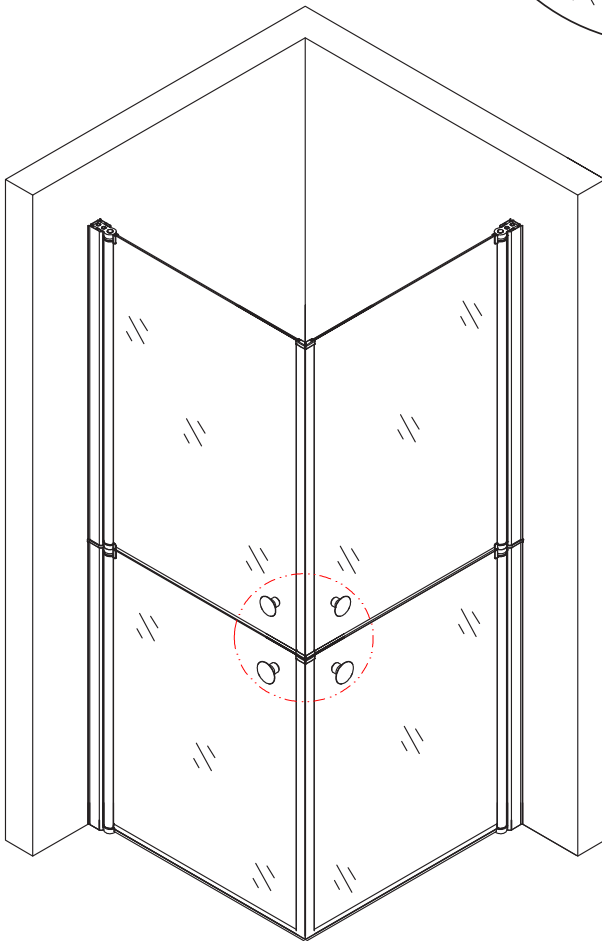
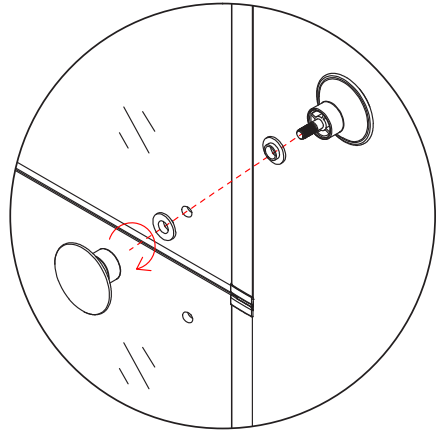

9

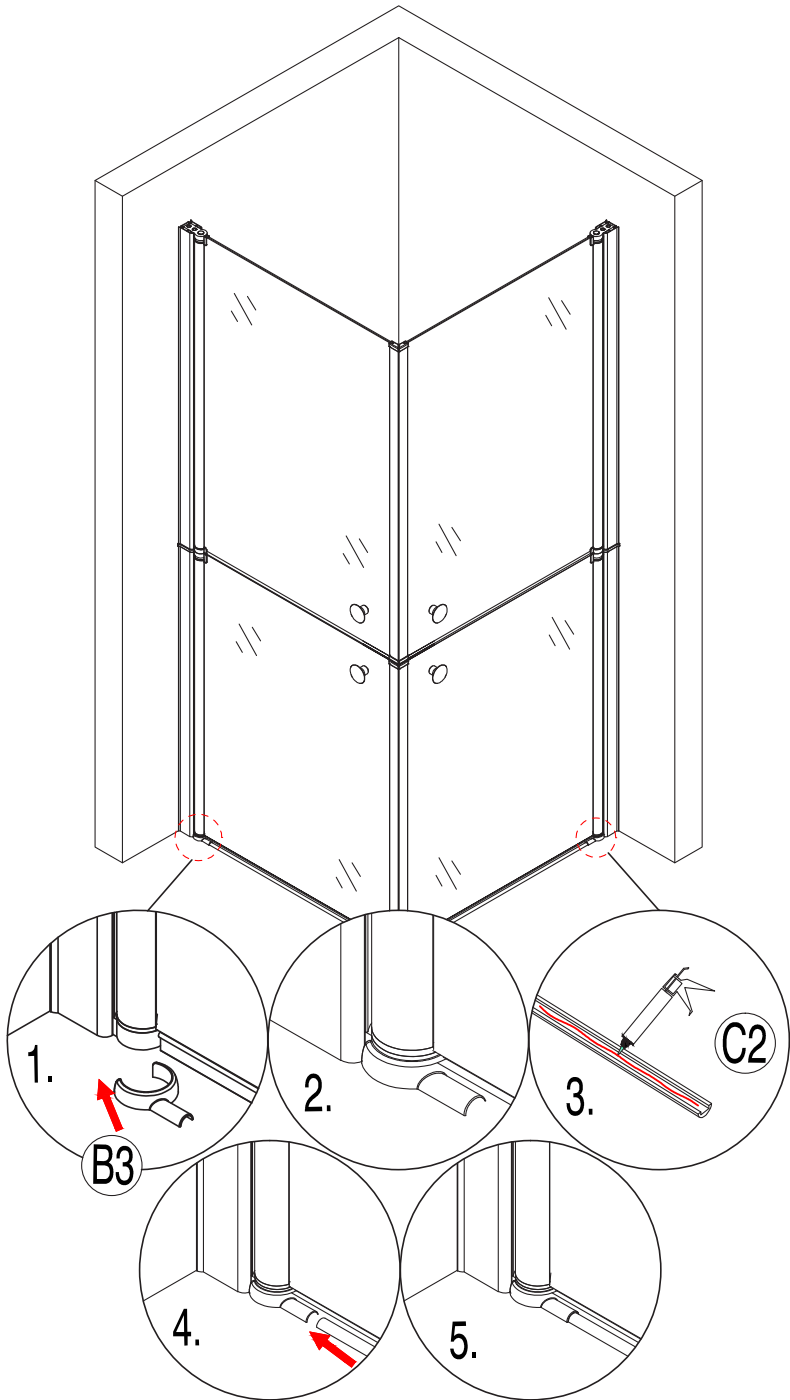

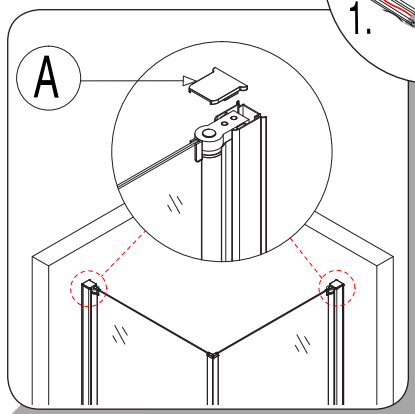
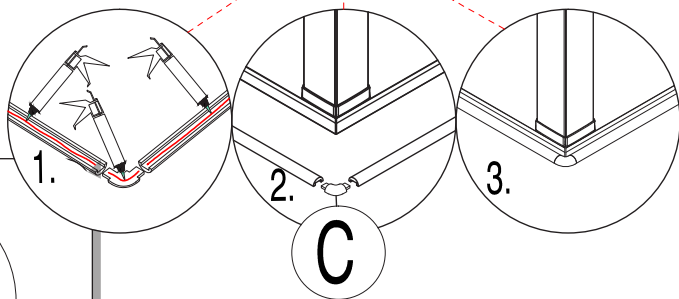
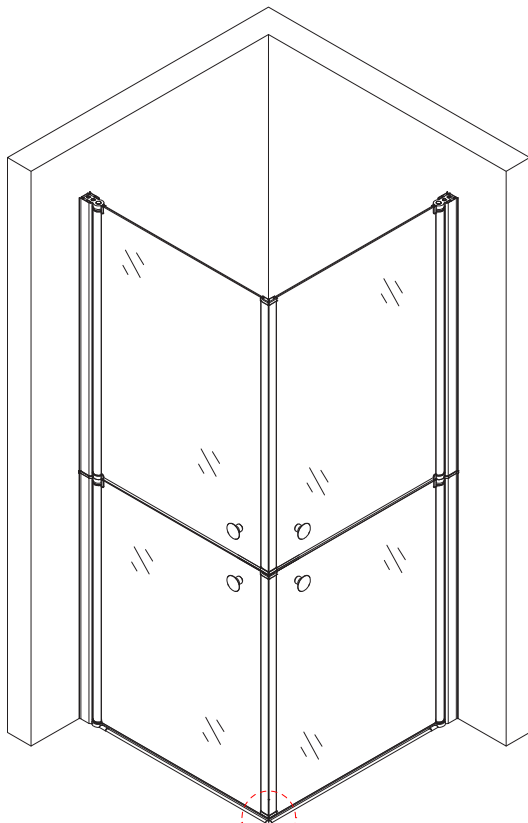

12

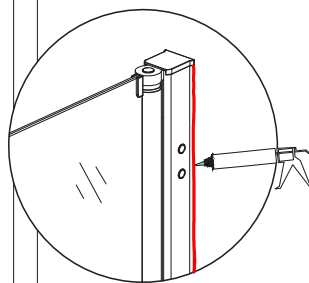
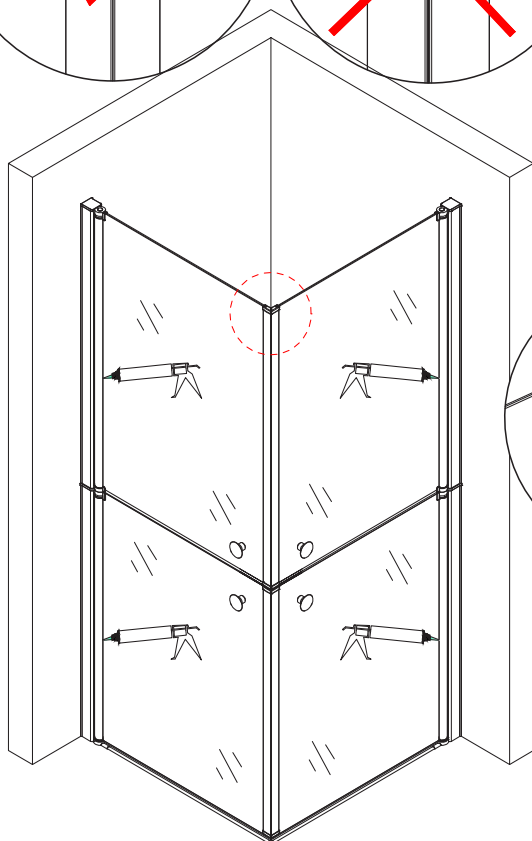
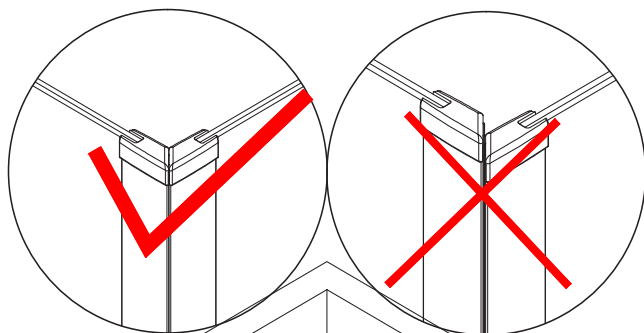
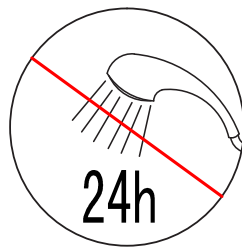



This Glass Screen is coated with a ClearShield® Protection System.

ClearShield® provides very effective protection, making shower glass always easier to clean and keep clean than unprotected glass, resisting staining and maintaining the hygienic environment and visual appeal much longer. Specially formulated for the use on ClearShield® glass and ceramics. It is also effective on most metal and plastic surfaces.

ClearShield® Glass requires cleaning less than half as often as ordinary glass. We recommend that you base the frequency of cleaning by halving your current cleaning regime, and either increase or decrease it as required. To optimize the performance and durability of the unique protection, we recommend the following basic maintenance programme.

Rinse off soap and water deposits on a regular basis as necessary, ideally drying off with a squeegee or cloth if required. Clean glass panels weekly (depending on usage and hardness of water).

AKW showering and daily living products have been developed on the basis that they are cleaned regularly using normal domestic bathroom cleaning materials.

Do not use abrasive products, cloths, strong or concentrated acidic or alkaline cleaning materials as these may discolour or otherwise damage the product.

The use of strong or concentrated acidic, alkaline, chlorine or other cleaning materials will invalidate any warranty as this may discolour or otherwise damage the products.

DO NOT place matches, cigarettes or naked flames on or near this product.

Do Not Use abrasive pads or cleaner on the protective glass service this will invalidate any warranty and effect the surface finish quality.

Alternatively clean with a non-abrasive daily cleaner and rinse with copious amounts of water and wipe dry with a soft non-abrasive cloth.

** The durability of the ClearShield® protection may be affected by the frequency of use of the shower, hardness of the water and the type of cleaning compounds and methods used. Such matters are outside the control of the manufacturer.*

It is recommended that only AKW screens should be used with AKW shower trays.

These products have been designed and manufactured to complement each other.

Their use with non AKW products may adversely affect the integrity of the water seal between the shower base and doors.



CLEAN GLASS
TECHNOLOGY

Cette écran Verre est revêtue d'une ClearShield® protection Système.

ClearShield® Shower Glass Protect offre une protection optimale, facilitant le nettoyage de votre verre, tout en la protégeant plus longtemps. En outre, le vernis résiste aux taches et préserve plus longtemps l'hygiène et l'attrait visuel de l'environnement. Formule spéciale pour le verre et les céramiques ClearShield®. Son efficacité est également garantie sur la plupart des surfaces métalliques et plastiques.

Grâce à ClearShield® Glass, les nettoyages sont réduits de moitié par rapport à un verre ordinaire. Nous vous recommandons au début de réduire de moitié votre fréquence actuelle de nettoyages, puis de l'adapter en l'augmentant ou en la réduisant. Afin d'optimiser la performance et la durabilité de cette protection unique, nous vous recommandons le programme d'entretien suivant. Rincez les dépôts de savon et d'eau à intervalles réguliers, si nécessaire en essuyant à l'aide d'une raclette ou d'un chiffon. Nettoyez les panneaux vitrés chaque semaine (en fonction de l'usage et de la dureté de l'eau).

Les produits de douche d'AKW ont été conçus pour résister à un nettoyage régulier à l'aide de nettoyeurs pour salle de bains domestiques.

N'utilisez pas de produits ou de tissus de nettoyage abrasifs présentant une forte concentration acide, alcaline ou autre, car ils pourraient décolorer ou endommager le produit.

L'utilisation de produits de nettoyages présentant une forte concentration acide, alcaline ou autre peut annuler la garantie, car ces produits pourraient décolorer ou endommager le produit.

N'approchez PAS ou NE déposez PAS d'allumettes ou de cigarettes près de ce produit.

N'utilisez pas de tampons ou de nettoyant abrasifs sur le verre de protection, sous peine d'annuler la garantie et de détériorer la qualité de finition de la surface.

Alternativement, nettoyez à l'aide d'un nettoyant non abrasif pour un usage quotidien et rincez abondamment à l'eau, puis essuyez à l'aide d'un chiffon doux non abrasif.

** La durabilité de la ClearShield® protection peut être affectée par la fréquence d'utilisation de la douche, la dureté de l'eau et le type d'agents et de méthode de nettoyage utilisés. De telles questions ne relèvent pas du fabricant.*

Nous recommandons d'utiliser exclusivement des parois AKW avec des receveurs de douche AKW. Ces produits ont été conçus et fabriqués pour se compléter. Leur utilisation avec d'autres produits peuvent affecter négativement l'intégrité de l'étanchéité entre le receveur et les portes.

Informations relatives à la garantie

Les parois en verre sont couvertes par une garantie de 2 ans

Veuillez compléter et retourner la carte de garantie dans les 30 jours suivant la date d'achat afin qu'elle soit validée. Un non respect de cette échéance entraînera une réduction de la garantie à 1 an pour tous les produits.

Non couvert par la garantie
Dommages ou défauts découlant d'une installation incorrecte, d'un usage inadéquat ou d'un manque d'entretien, y compris l'accumulation de tartre ou toute modification non autorisée par AKW.

Actions de démontage, de réparation ou de modification par des personnes qui ne sont pas des techniciens ou agents agréés AKW.
Dommages résultant du gel de l'eau.

Les produits d'AKW doivent être installés par des personnes expérimentées et compétentes, utilisant les fixations adéquates et correspondant à l'état des surfaces sur lesquelles le produit sera posé.

La sélection de fixations spécifiques doit être réalisée par l'installateur selon les exigences de chaque installation individuelle.

Service commande

+32 (0) 68 334899
+32 (0) 68 646645

Fax

+32 (0) 68 331658

Site Web

www.akw-medicare.eu

Offres et commandes

ism@akw-medicare.com

Courrier

AKW International S.A.
Rue de la Villa Romaine, 3
7822 Ghislenghien
Belgium

Un non respect des instructions fournies concernant l'installation ou toute modification du produit AKW non autorisée annulera la garantie et affectera la sécurité du produit.

Warranty information

Glass Screens are covered by 2 year warranty.

Please complete warranty card and return it within 30 days of purchase to be validated. Failure to meet this deadline will result in a 1 year warranty on all products.

Not covered by any warranty Damage or defects arising from incorrect installation, improper use, lack of maintenance including the build-up of limescale or any AKW unauthorised modifications. Actions taken to dismantle repair or modify by persons who are not AKW authorised service staff or agents. Damage resulting from water freezing.

AKW products should be installed by experienced and competent persons using appropriate fixings suitable the condition of the surfaces on which the product is to be attached.

The selection of any specific fixings must be made by the installer based upon the requirements for each individual installation.

Orderline

+44 (0) 1905 823299

General Enquires

+44 (0) 1905 823298

Technical Help line

+44 (0) 1905 560219

Fax

+44 (0) 1905 823297

Website

www.akw-ltd.co.uk

Quotes & orders email

orders@akw-ltd.co.uk

Enquires email

sales@akw-ltd.co.uk

technicalenquiries@akw-ltd.co.uk

For latest AKW news and products, scan this code with your phone or tab device.



Post

AKW, Pointon Way, Hampton Lovett,
Droitwich Spa, WR9 0LR

Failure to install this AKW product in accordance with supplied instructions or the making of unauthorised modifications will invalidate any warranty and will affect product safety.