

Assembly instructions

Rev. 10/08 ENG

8500 SF 24V belt driven garage door opener



UK HELP-LINE:
0845 136 2012
 Mo-Fri: 0900-1900
 Sat: 0900-1700
 Sun: 1000-1600



Max traction:
70 kg
max. 8 m²



Power;
230 V / 50 Hz



Gear
8-24 V dc



Opening time
11-18 sec.

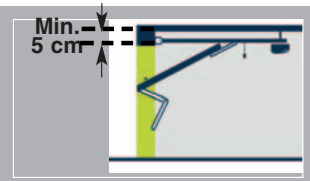
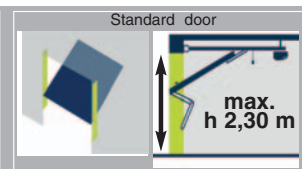
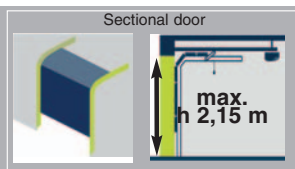
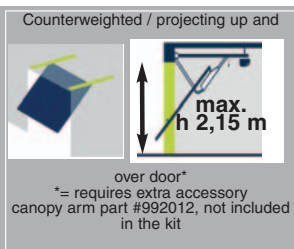

CAUTION:
 Only to be installed on well-balanced doors.

CAUTION:
 Carefully read these mounting instructions before installation.
 If you need further information, contact the manufacturer:
 Allducks or UK Customer Support, HELP LINE:
 UK HELP LINE: 08451362012

Allducks srl
 via Alessandro Volta, 1
 20060 Ornago (MI) Italy
 Ph. +39/039/6010654
 Fax +39/039/6011243
 service@allducks.it
 www.allducks.it

Index

| CHAPTER | CONTENTS | PAGE |
|---------|--|-------|
| | WARNING | 3-4 |
| 1. | Kit contents | 5 |
| 2. | Technical specifications | 5 |
| 3. | Garage door types | 6 |
| 3.1 | Standard non-projecting up-and-over door | 6 |
| 3.2 | Sectional door | 6 |
| 3.3 | Projecting up-and-over door | 6 |
| 4. | Operating limits and installation scheme | 7-9 |
| 5. | Assembly instructions | 10-12 |
| 6. | Attachment instructions | 13-14 |
| 7. | Manual release system | 15 |
| 8. | 230V power supply | 16 |
| 9. | Remote control coding | 17 |
| 10. | Power adjustment | 17 |
| 11. | CTH29S electronic panel | 18 |
| 12. | Setting the travel limits | 19 |
| 13. | Automatic closing | 20 |
| 14. | Maintenance | 20 |
| 15. | Fast troubleshooting | 20 |
| 16. | Warranty & customer support | 21 |
| 17. | Replacement parts | 21 |
| 18. | Optional accessories | 21 |
| 19. | Declaration of conformity | 22 |



Very Important Safety WARNINGS



WARNING: This garage door opener has been designed and tested to offer safe service provided it is installed, operated, maintained and tested in strict accordance with the instructions and warnings contained in this manual.

Please read this instruction manual carefully before you proceed with installation of your garage door opener, and make sure that the door's weight, dimensions and type are within the limits for this opener model.

The structure of the door and the walls or pillars must be sound and stable.

Install the opener only on a properly balanced and lubricated garage door.

All repairs to cables, spring assemblies and other hardware must be made by a trained professional door systems technician **BEFORE** the garage door opener is installed.

To prevent serious injury or death, always call a trained, certified door systems technician if the door binds, sticks or is out of balance.

An unbalanced garage door may not reverse when required and could result in serious injury or death!

Never try to loosen, move or adjust the garage door, door springs, cables pulleys, brackets or their hardware, all of which are under **EXTREME** tension.

To avoid entanglement, disable all locks and remove all ropes connected to garage door before installing and operating the garage door opener.

To prevent damage to the garage door and opener: Always disable the locks before installing and operating the opener.

Never wear watches, rings or loose clothing while installing or servicing the opener. They could get caught in the garage door opener mechanisms.

Place entrapment warning labels on the wall next to garage door control.

Place manual a release/safety reverse label in plain view on the inside of the garage door.

Upon completion of installation, test to make sure that your garage door opener is working correctly, and test the safety system. The door must reverse when it contacts an object on the floor.

To prevent injuries:

Never leave children unsupervised near a garage door opener, whether moving, open, closed or stopped.

Never permit children to play with the garage door opener's remote control buttons or transmitters, and do not allow children to use them to operate the door opener. Always keep remote controls out of reach of children.

Install wall-mounted garage door controls (optional) out of the reach of children and away from moving parts of the door.

Activate the door only when it can be seen clearly, is properly adjusted and there are no obstructions to door travel.

Always keep the garage door in sight until completely closed.

Never permit anyone to cross the path of a closing garage door.

No one should go under a stopped, partially open garage door.

Always make sure you have connected the unlocking cable in order to allow the garage door to be manually unlocked (from inside and out), and operate it manually if there is a power failure or other problem.

To prevent damage, never leave cars, motorcycles or similar objects under the garage door.

Without a properly working safety reversal system, people (particularly small children) can be SERIOUSLY INJURED or KILLED by a closing garage door.

The safety reversal system could fail if the garage door opener is not correctly installed and if limit switches are not adjusted to the correct positions.

Please check the instructions in this manual thoroughly and test after installation to verify power adjustment and settings.

Incorrect adjustment of garage door travel limits will interfere with proper operation of the safety reversal system.

Too much force on the garage door will interfere with proper operation of the safety reversal system. Never increase force beyond minimum amount required to close the garage door.

Never use force adjustment to compensate for a binding or sticking garage door. After any adjustment is made, the safety reversal system must be tested.

To prevent serious injury or death:

The head bracket must be rigidly fastened to a structural support on a header wall or ceiling.

To avoid serious injury from a falling garage door opener, fasten it securely to structural supports of the garage.

Concrete anchors must be used when installing any brackets into masonry.

To prevent serious injury or death by electrocution:

Be sure the power is not connected BEFORE installing the door control.

NEVER connect the garage door opener to the power source until instructed to do so.

The garage door installation and wiring MUST be in compliance with all local electrical and building codes.

SAVE THESE INSTRUCTIONS

1. Kit contents

kit 8500SF

Complete gear 24V DC with CTR29S electronic panel, receiver and transformer

One rolling code, 2 radio transmitting channels at 433.92 MHz

Belt drive

270 cm iron "U" rail (3 x 90cm) with 2 connectors

Manual unlocking device from inside/outside

Mounting hardware (pre-assembled)

Mounting instructions

Figure 1

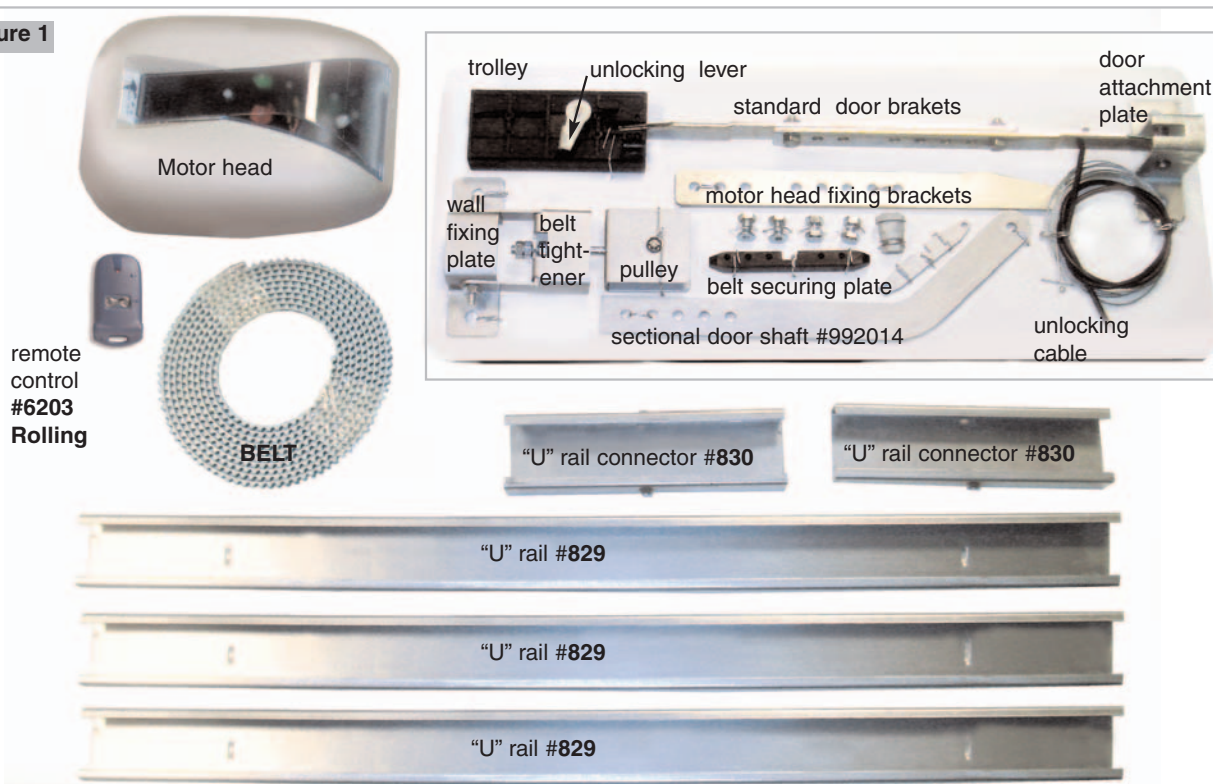

2. Technical specifications

| | |
|------------------------------------|-------------------------|
| Power (Vac 50/60 Hz) | 230V |
| Traction (N) | 100 |
| Power absorbed (W) | 80 |
| Toroidal transformer | 105W |
| Protection Fuse | 0,8A T |
| Radio frequency & coding | 433,92 MHz rolling code |
| Speed (m/sec.) | 0,15 |
| Operating temperature (°C min/max) | -10/+50 |
| Courtesy light | Yes, automatic |
| Amperometrical safety system | Yes |
| Power adjustment | by adjustment screw |
| Travel limits | double limit switch |
| Automatic closing | Yes |
| Soft stop | Yes |

3. Garage door types

3.1 Non projecting up-and-over door

For installation on a non-projecting up-and-over door, no extra accessories are needed.

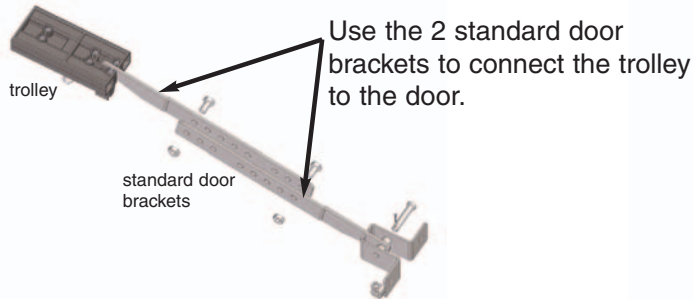

Figure 2

3.2 Sectional door

For installation on a sectional door, 1 of the 2 supplied standard brackets must be replaced by the supplied sectional door shaft #992014.

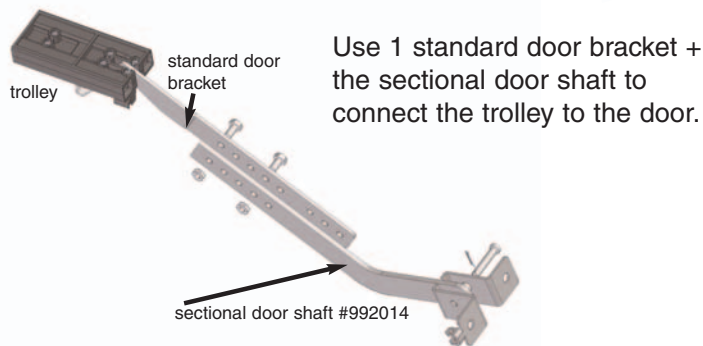

Figure 3

3.3 Projecting up-and-over door

For installation on a projecting up-and-over door, the extra "canopy arm" accessory item #992012* is required.



Figure 4

4. Operating limits and installation

To attach the rail of the garage door opener, a minimum distance of 5 cm is required between ceiling and door. And a minimum distance of 1 cm is required between rail and door (see Figure 6).

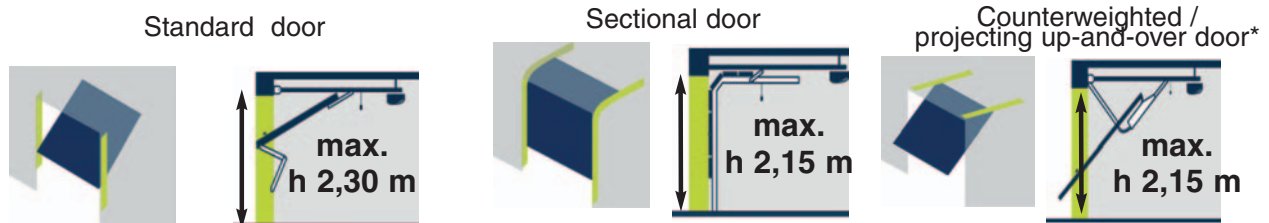
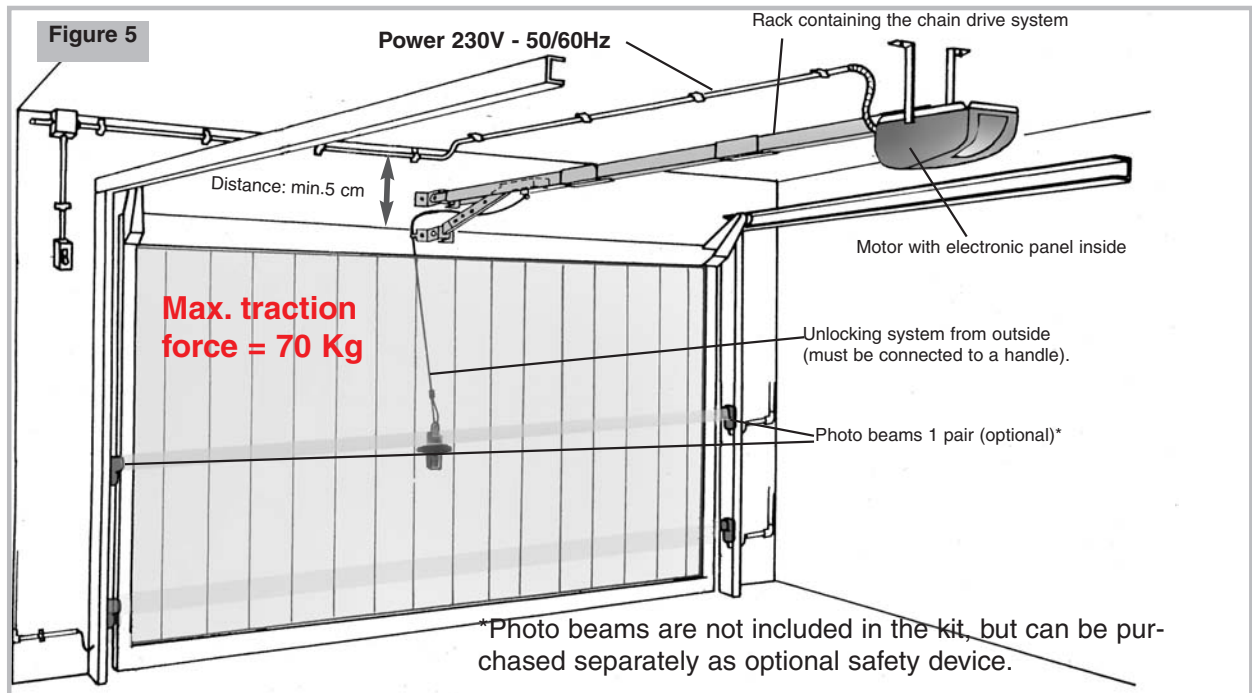

*= requires extra accessory canopy arm part #992012 not included in the kit

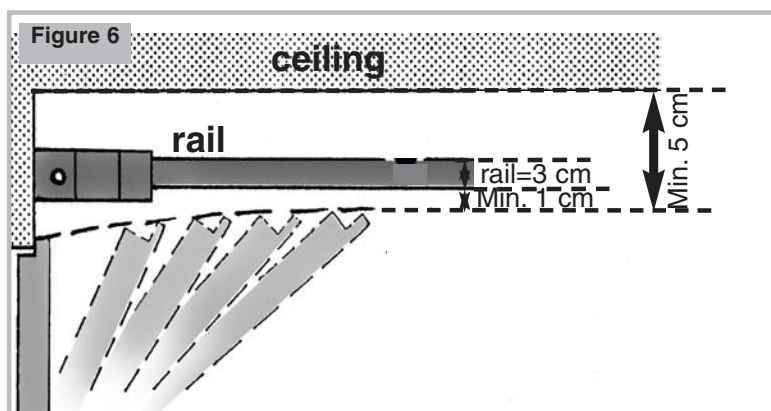

Installation scheme

Figure 7

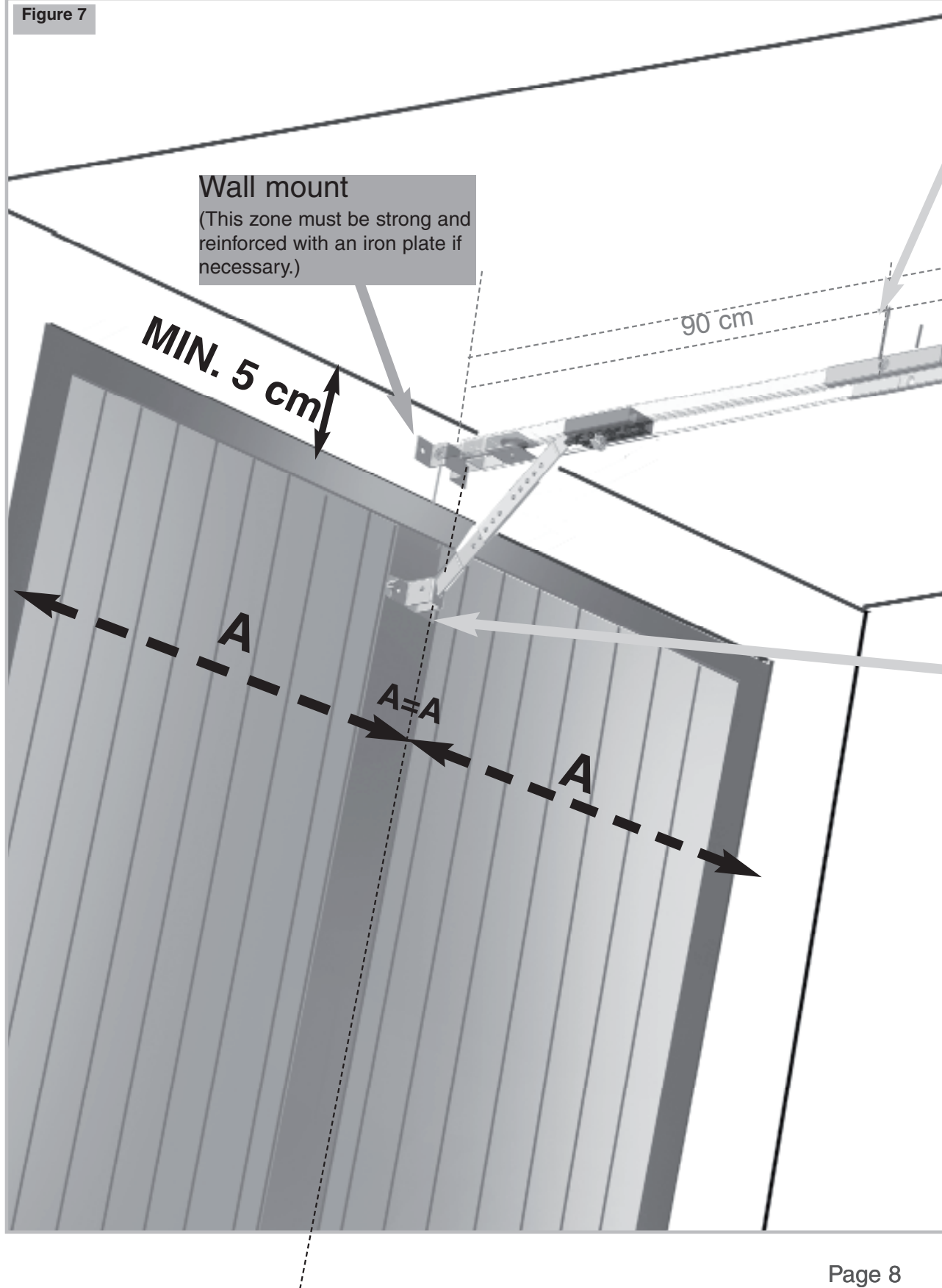

extra rail support

Rail parts "830" can additionally be attached to the ceiling with a cable.

Gear support

The gearbox must be attached to the ceiling with the supplied parts "821".

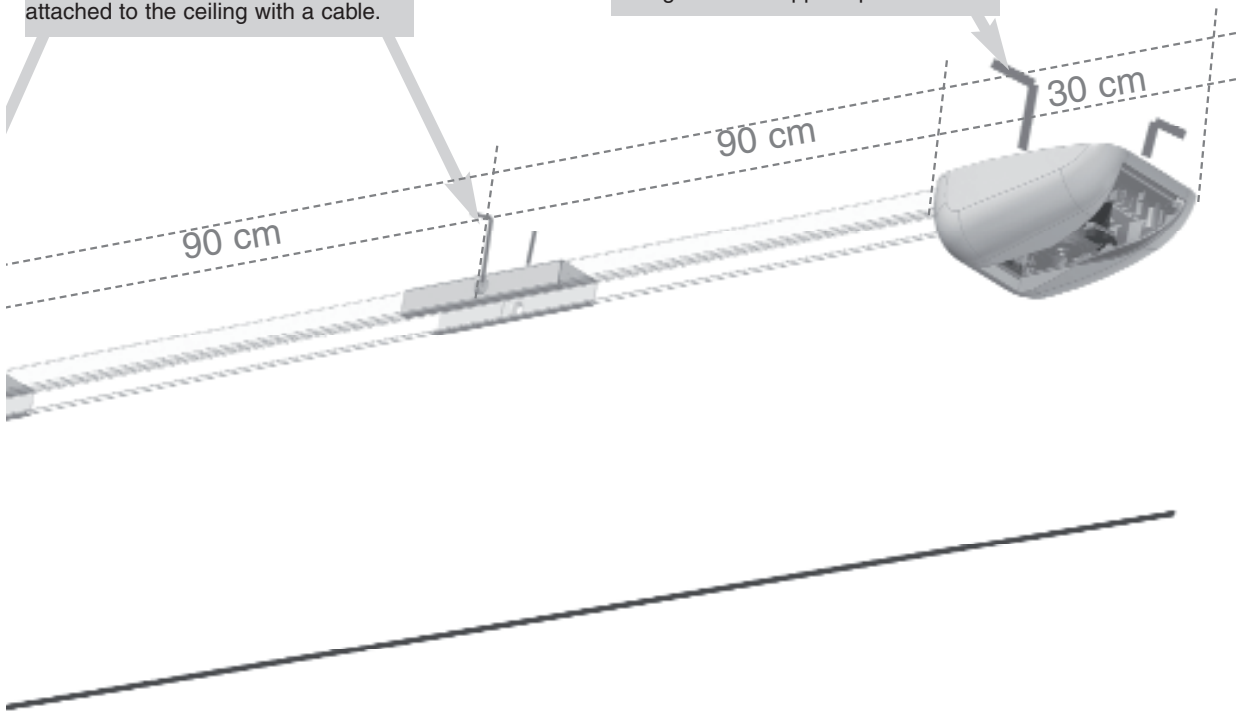

Door mount

(This zone must be strong and reinforced with an iron plate if necessary.)



CAUTION:

To prevent injury from pinching, keep hands and fingers away from the joints while assembling the rail.

To avoid serious injury to fingers from a moving garage door opener:

Always keep hands clear of sprocket while operating opener.

Securely attach sprocket before operating.

5. Assembly instructions

Step 1: "U" Rail assembly

Assemble the 3 elements of the rail (part #829) by fitting them into the 2 rail braces (part #830). See Figures 8-10.

Figure 8

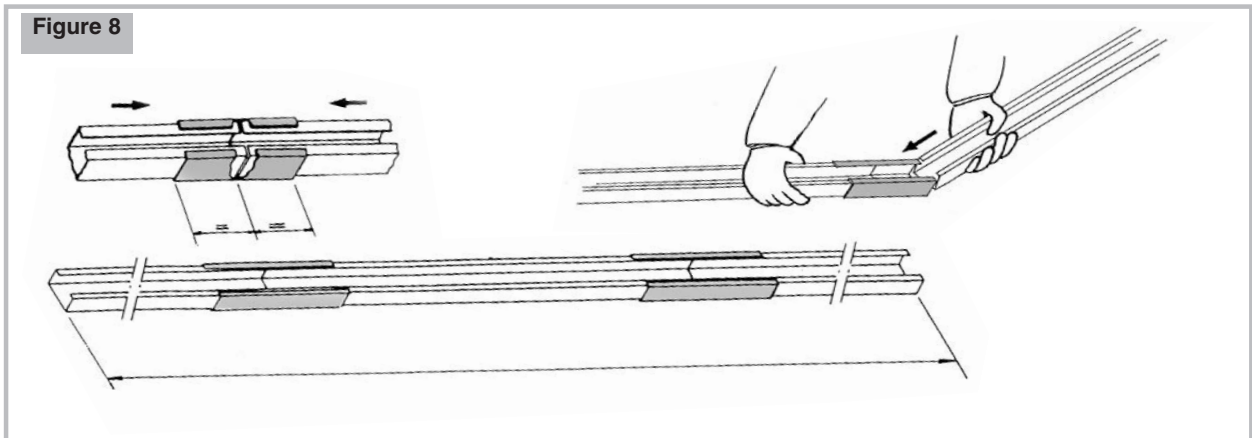

Figure 9

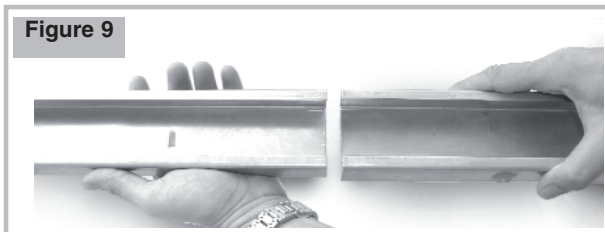
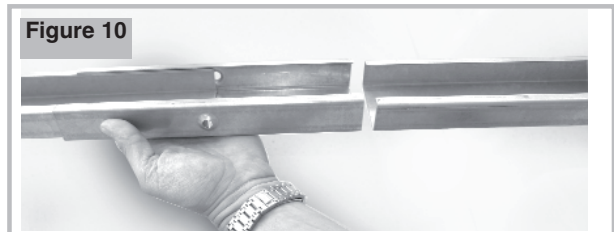

Figure 10



Step 2: Attaching the belt into the trolley and around the pulley.

The pulley and trolley are supplied pre-assembled:

Figure 11

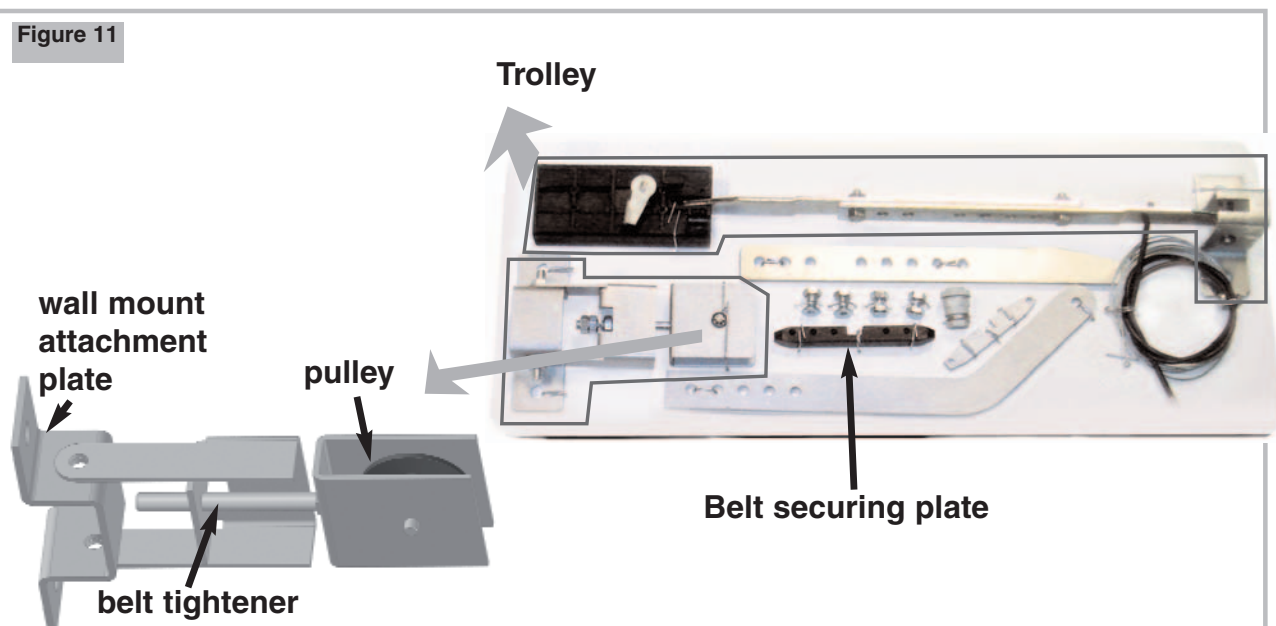

Slide the belt through the trolley as shown in Figure 12 and then pass it around the pulley. Lock the belt with the securing plate as shown in Figure 13-14.

WARNING: The securing plate must connect the belt in a specific position: on the side opposite to the unlocking plug fixed on the trolley, and between the trolley and the pulley. The notch must face inward (Figure 12).

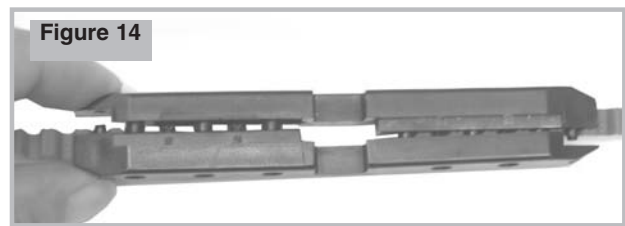
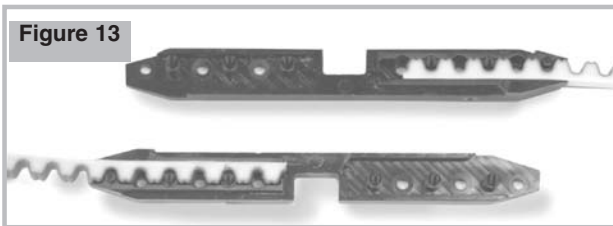
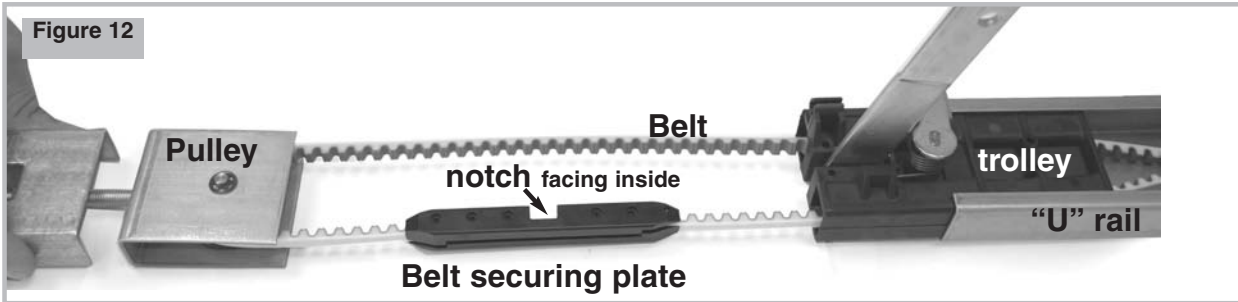

Step 3: Sliding the trolley with belt and pulley into the "U" rail

Slide the assembled belt, trolley and pulley into the assembled "U" rail.

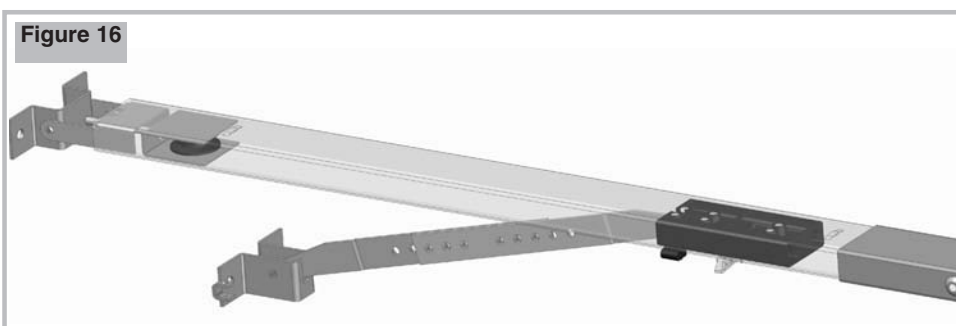
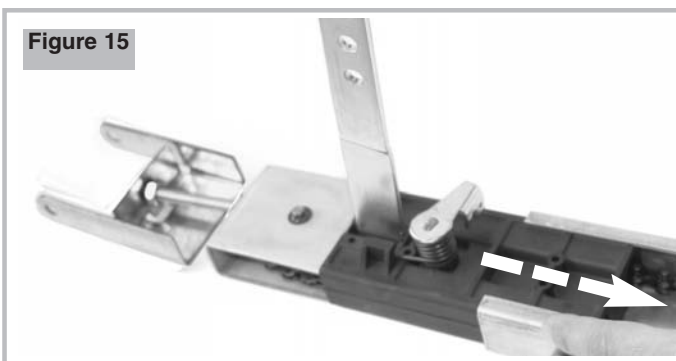

Step 4: Connecting the belt to the pulley on the motor

Turn the motor head, and take off the pulley cover. Slide the belt around the pulley (Figure 17). Put the pulley cover on and attach it with the screws (Figure 18). Insert the "U" rail into the plate through the guides until it stops (Figure 19-20).

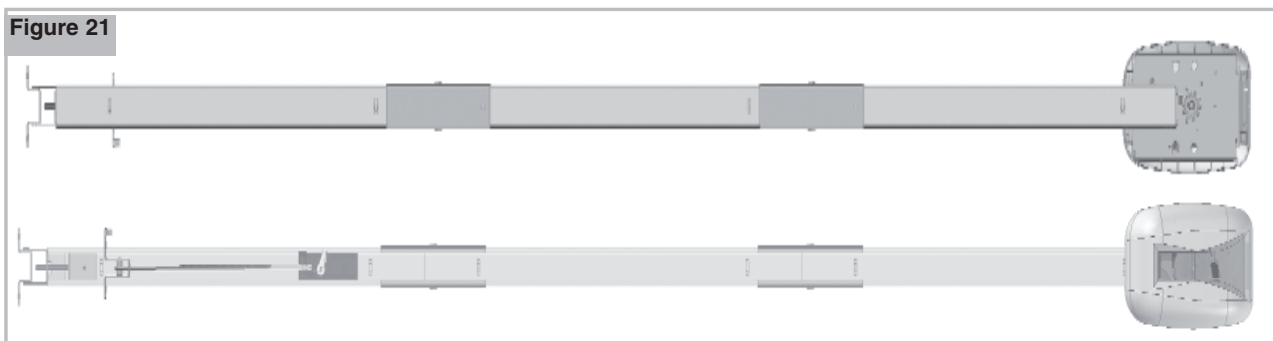
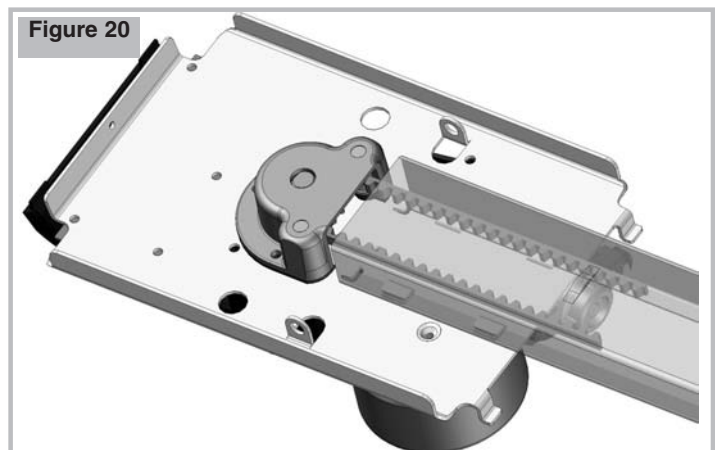
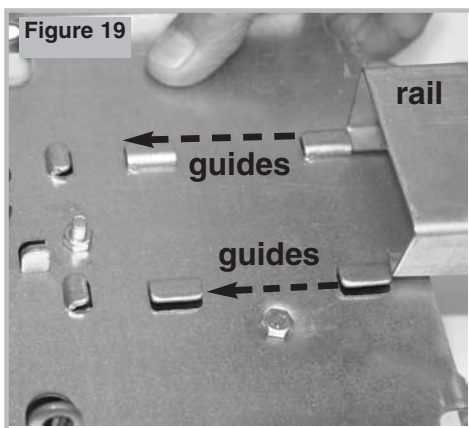
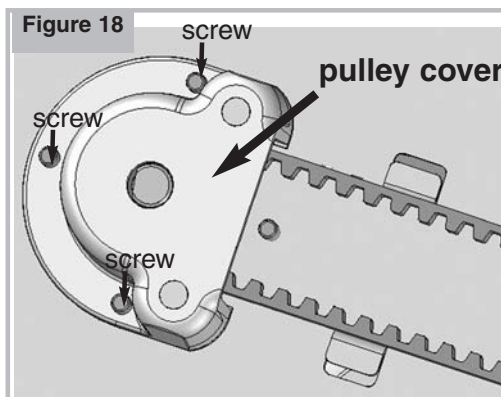
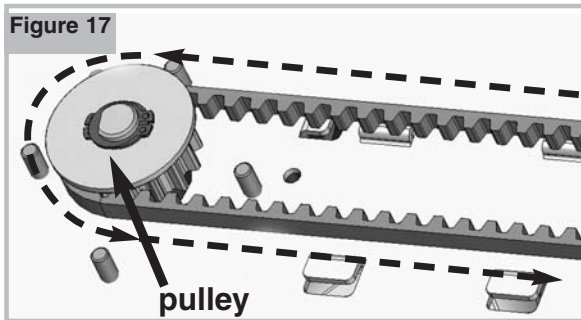
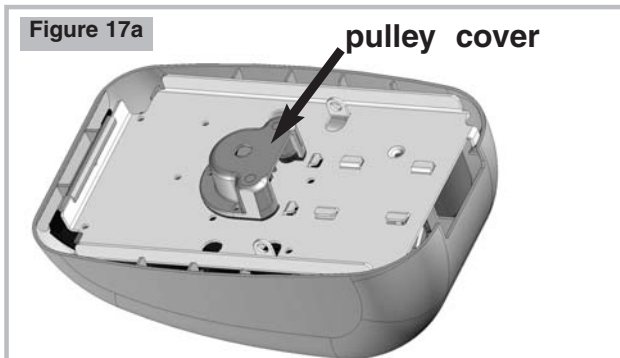

NOW your garage door opener is fully assembled and ready to be attached to the door.

6. Attachment instructions

Step 5 Door jamb mount:

Position the pilot holes horizontally on the vertical centre line of the door.

Fasten the 828 bracket to the door jamb or wall by means of 2 bolts (not supplied) of the right size and type for the structure.

Take and hold the opener to a horizontal position until it can be attached to the ceiling. (Figure 24).

Warning: the fastening area must be reinforced and structurally resistant.

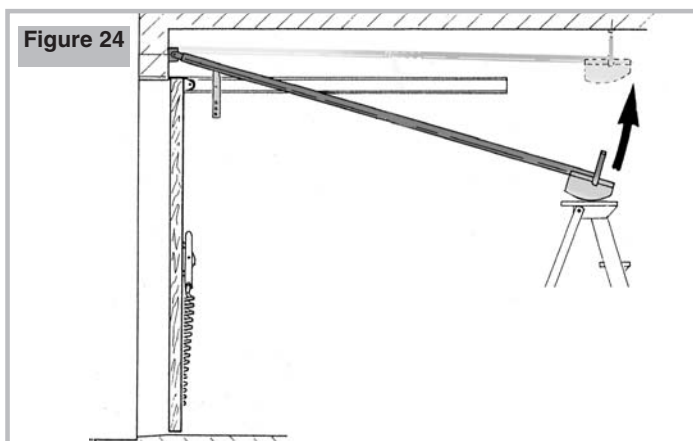
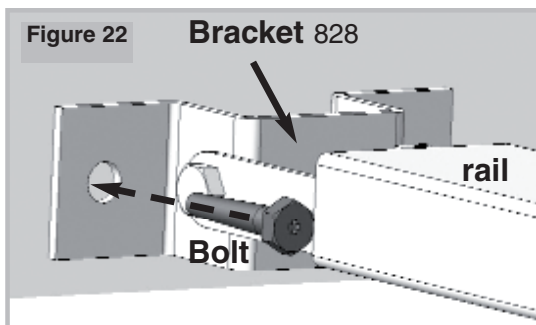

Step 6 Motor Head Mount:

Hanging the motor head

The hanging brackets must be attached to the motor plate and angled at 90° at the ends, as shown in Figures 25-27. Then fasten the brackets to the ceiling.

The rail can be fastened to the ceiling through the holes in the rail braces, in order to prevent the rail from warping. This is a useful solution especially when utilising accessory 992012 (up-and-over doors).

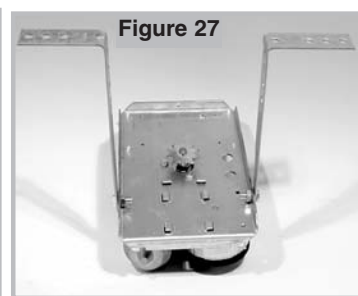
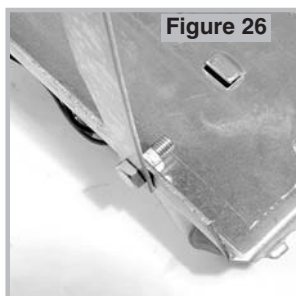
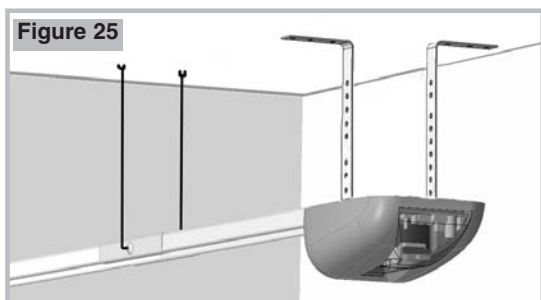

Step 7 Attaching the door

Close the garage door.

The attachment plate 809 is supplied pre-assembled to the trolley by 2 brackets. These brackets are supplied for installation on a **STANDARD NON PROJECTING UP-AND-OVER DOOR**.

- 1) Push the unlocking handle left to release it, and manually move the trolley (Figure 28).
- 2) Slide the trolley to the front and advance the brackets to find the right attachment position for plate 809.
- 3) If necessary, adjust the length of the brackets by sliding them one on another and fix the appropriate holes.
- 4) Fasten plate 809 to the door by means of 2 bolts (not supplied) of the right size and type for your door (Figure 30).

Warning: The fastening area must be reinforced and structurally resistant.

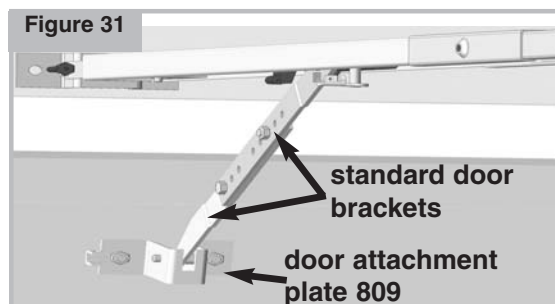
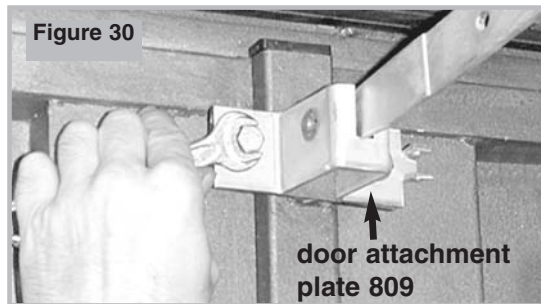
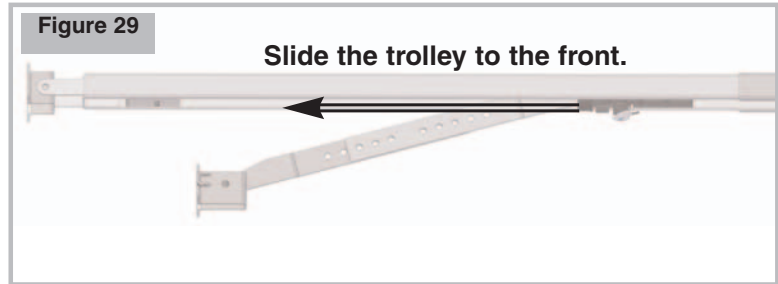
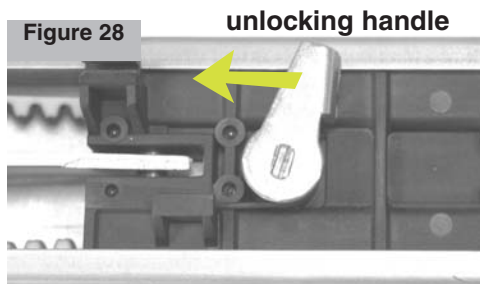

WARNING: For installation on a sectional door

For installation on a sectional door, 1 of the 2 supplied standard brackets must be replaced by the supplied sectional door shaft #992014 as in Figure 32a. (see also page 6 point 3.2)

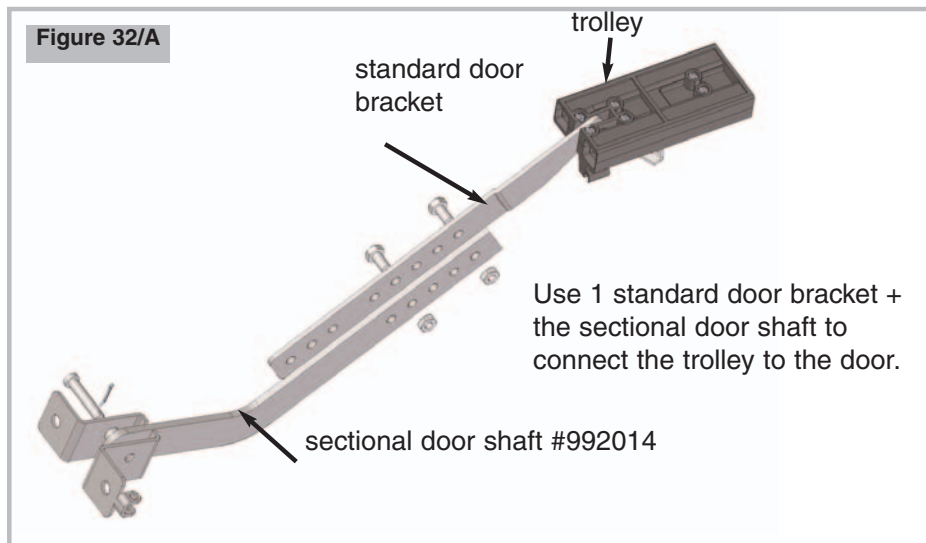

WARNING:

For installation on a projecting up-and-over door,

an extra canopy arm (not supplied in the kit) is required to connect the trolley to the door) as in Figure 32b.

Please see also page 6 point 3.3.

Please refer to the specific instruction manual supplied with the canopy arm (purchased separately).

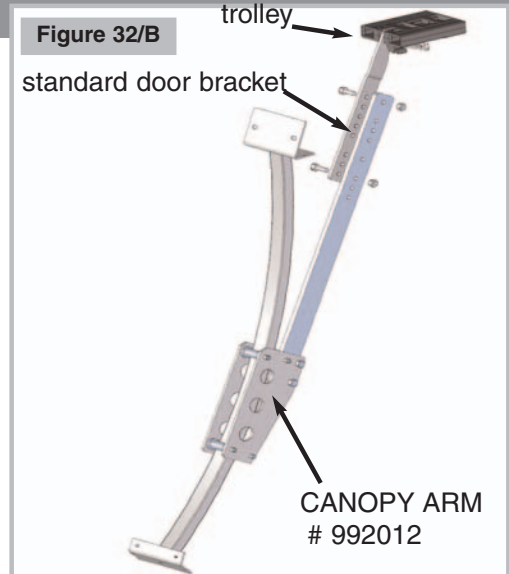

Step 8: belt tightener

Once the opener has been installed, tighten the belt using the belt tightener as shown in Figure 33, so that the belt does not swing excessively during movement. Do not over tighten the belt.

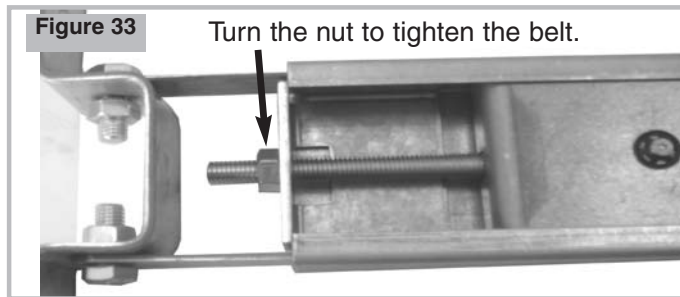

7. Manual release system

An unlocking system is provided to unlock the trolley and move the door manually. Composed of an iron cable and its sheath, it must be connected to the unlocking mechanism positioned on the trolley. Pass the iron cable through the hole of the handle and slide it into the sheath (Figure 34). Then pass the iron cable and sheath into the door attachment plate (Figure 36).

Attach the iron cable to the door handle, using the supplied cable compressor (Figures 37-38).

To unlock the door from inside or outside rotate the door handle counter clockwise (Figure 38).

To lock the trolley, move the door manually until the belt securing plate fits into the trolley again. (This will happen automatically while the door is moving.)

WARNING: To control the door with your radio remote control, the trolley must be locked!

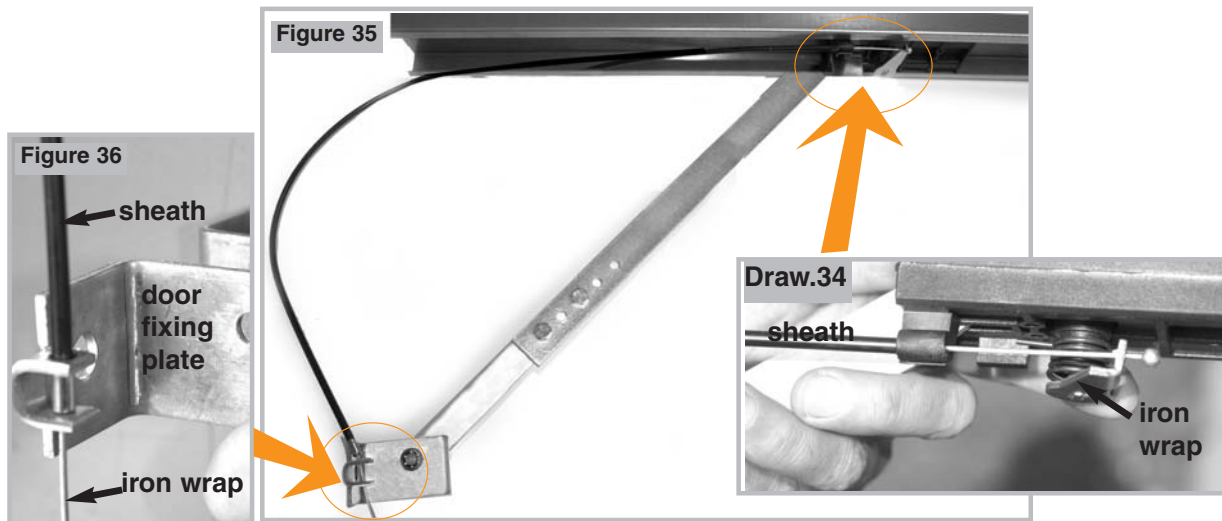

Cable connection to manually unlock the door from inside and outside.
Connect the cable to the handle. Turn the handle to unlock.

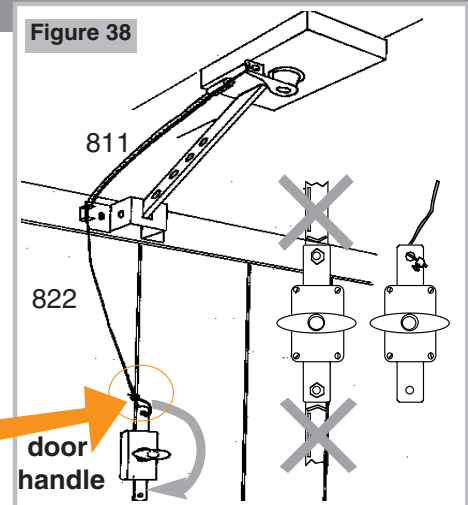
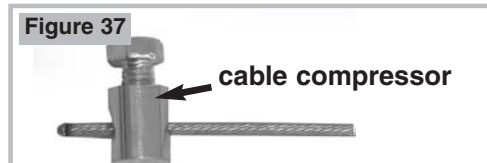

8. 230V power supply wiring



Lift the motor cover (Figures 39-40).

Connect the 230 V 50/60 Hz input cable to the transformer terminal board (Figures 41, 42 and 43). A fuse is mounted on the transformer to protect low voltage system (Figure 42).

We recommend using a cable compressor (not supplied) to attach the cable when passing it through the motor plate (Figure 43).

Remember to check that the safety fuse is not blown, and if it is, replace it with a new one. When the operation is finished, close the cover.

CAUTION: A high voltage supply must be connected by a certified installer only! Working with 230V power is very dangerous. Risk of serious injury or death!

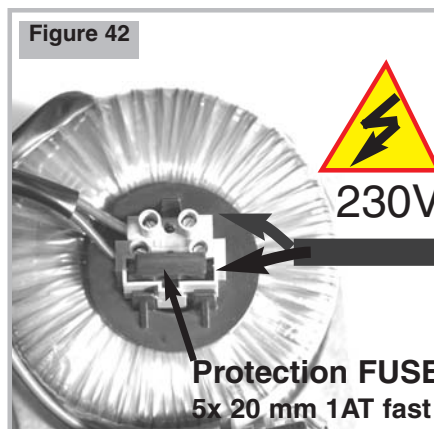
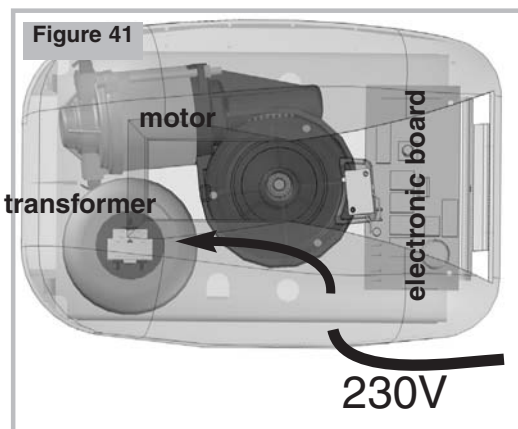
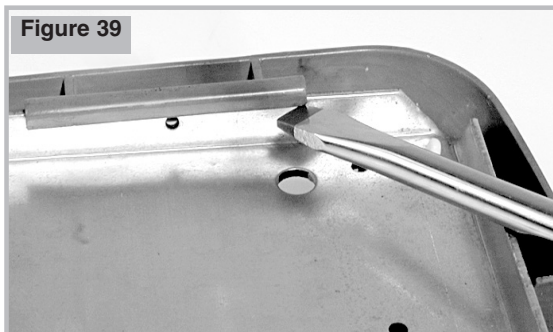

9. Remote control coding (6203 rolling code)

Rolling code remote 6203/rolling transmits a unique “rolling code” (billions of continuously changing combinations) at a frequency of 433 MHz. With 2 buttons, it has 3 transmission channels.

Channel 1 = push the "ON" button

Channel 2 = push the "OFF" button

Channel 3 = push the “ON” and “OFF” buttons simultaneously

To operate your gate, you must memorize the remote control code on the electronic panel.

WARNING: Make adjustments and settings only with the garage door in closed position.

To store the remote control code in the opener's electronic panel:

The door must be closed and idle.

- Press button P1 on the electronic panel. The red LED is on.

- Release button P1 and immediately press the buttons of the remote control that you wish to use to operate the opener. Hold the remote button down for about 4 seconds.

- the red LED on the electronic panel will blink rapidly.

Then it stays on for about 6 seconds before going off.

- Press the stored remote control button again, and the opener will begin to operate.

No more than 10 remote control codes can be stored in each electronic panel of the gate opener.

To erase codes from the control panel:

To deactivate any unwanted remote, first erase its memory from the electronic panel of your gate opener as follows (all stored remote control codes will be deleted):

- The door must be closed and idle.

- Press button P1 for about 20 seconds until the red LED blinks..

- Then release P1.

- All remote control codes have been deleted. - Reprogram each remote you wish to use.

Maintenance: To change the battery, remove the screw on the back of the remote and open the covers.

Use a 12V type A23-5mA battery.

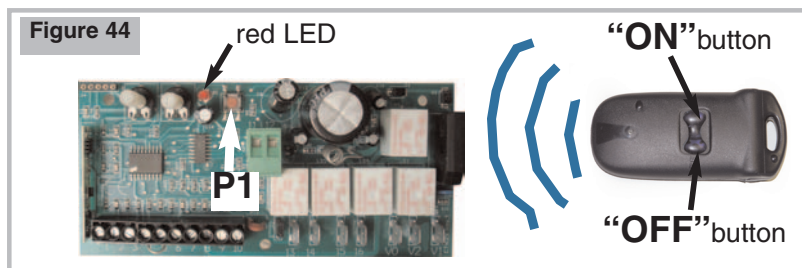

10. Power adjustment

The force can be adjusted by turning the force setting screw marked “POWER”.

It regulates the amount of power required to open and close the door.

Set the power according to your door weight and friction.

Press your remote control to operate the door in the down and in the up position to see if power is set properly.

Turn RV1 counter clockwise to increase power. Turn RV1 clockwise to reduce power.

WARNING:

If the power is set too low,

the door will stop before reaching the open or closed position.

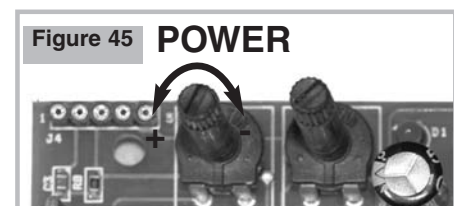

11. CTH29S electronic panel

Figure 46

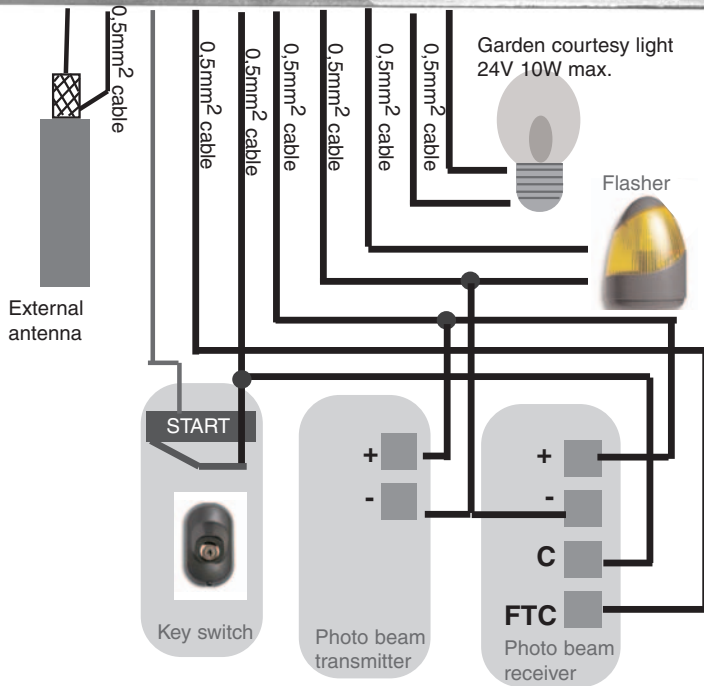
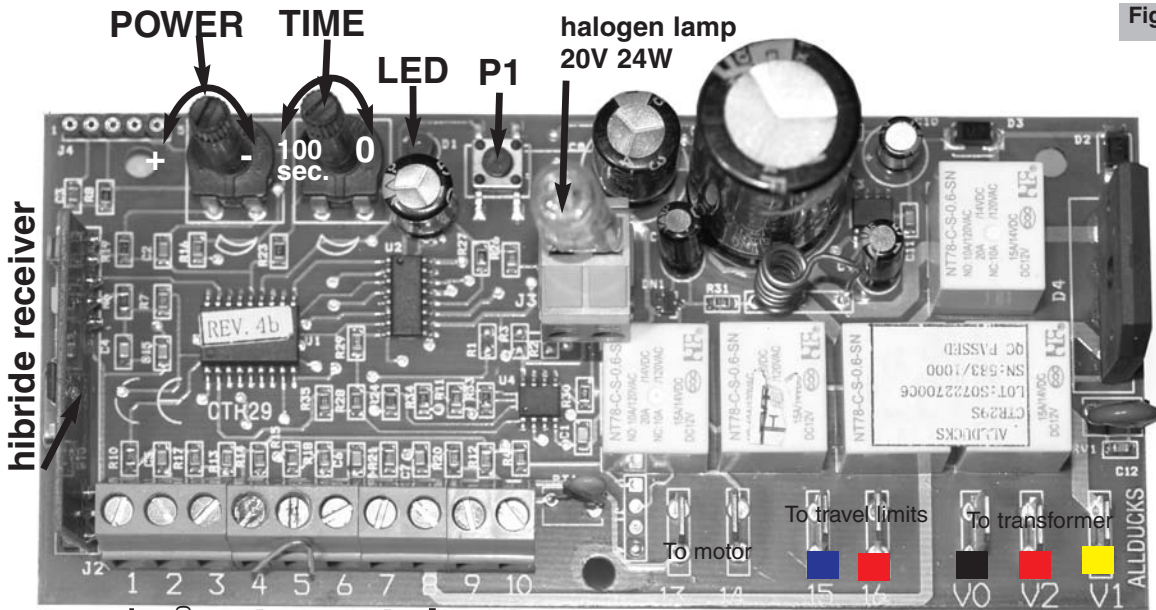

- P1** = Press button to store or delete remote control code.
- LED** = Red LED indicates storage or deletion of remote control codes.
- POWER** = force adjustment screw: Turn counter clockwise to increase power. Turn clockwise to reduce power.
- TIME** = adjusting screw to set the automatic closing timer adjustment 0-100 sec. Turn fully clockwise to set the step-by-step function. Turn counter clockwise to set the automatic closing function to a maximum pause time of 100 sec.
- 1** = ANTENNA CABLE
- 2** = GROUND Antenna
- 3/5** = START
- 4/5** = Photo beam contact
- 6** = PHOTO BEAM POSITIVE
- 7** = PHOTO BEAM NEGATIVE
- 7/8** = flasher 24V 10W max
- 9/10** = extra courtesy light
- 13/14** = limit switch connector
- 15 (+)** = motor blue cable connection
- 16 (-)** = motor red cable connection
- From transformer:**
- V0** black (= 0V);
- V2** red (= 24V);
- V1** yellow (= 12V)

WARNING:
If no photo beam is connected, the bridge between outlets 4 and 5 must remain connected.

12. Setting the travel limits

Warning: To set travel limits, you must check that:

The electronic panel is on **step-by step operating function =** "TIME" adjustment screw must be rotated clockwise all the way. See page 20;

Travel limits are the points at which the door will stop during each up or down operation. The 2 limit flags, red and green, will stop the door movement when they come into contact with the limit switch.

Red Flag = closed door

Green Flag = open door

- 1) When the door is closed: Position the red flag to touch the limit switch (Figure 47).
- 2) When the door is open: Position the green flag to touch the limit switch (Figure 48).

To set the travel limits:

- Unlock the trolley (see page 15).
- Manually close the door.
- With the door is in closed position, unscrew the red flag slightly, move it, and position it to touch the limit switch (the limit switch must be pressed by the red flag).
- Press your remote control to activate the opener. It will automatically relock the trolley while moving.
- While the door starts to open, unscrew the green flag slightly, move it, and when the door is in the desired open position, tightly screw in the green flag to touch the limit switch (the limit switch must be pressed by the green flag).

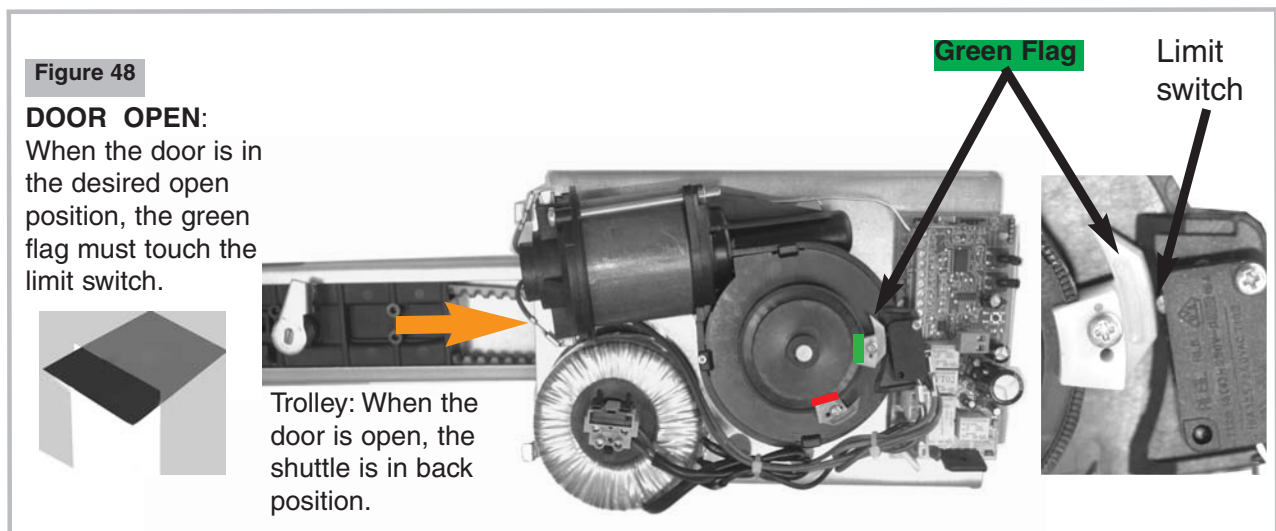
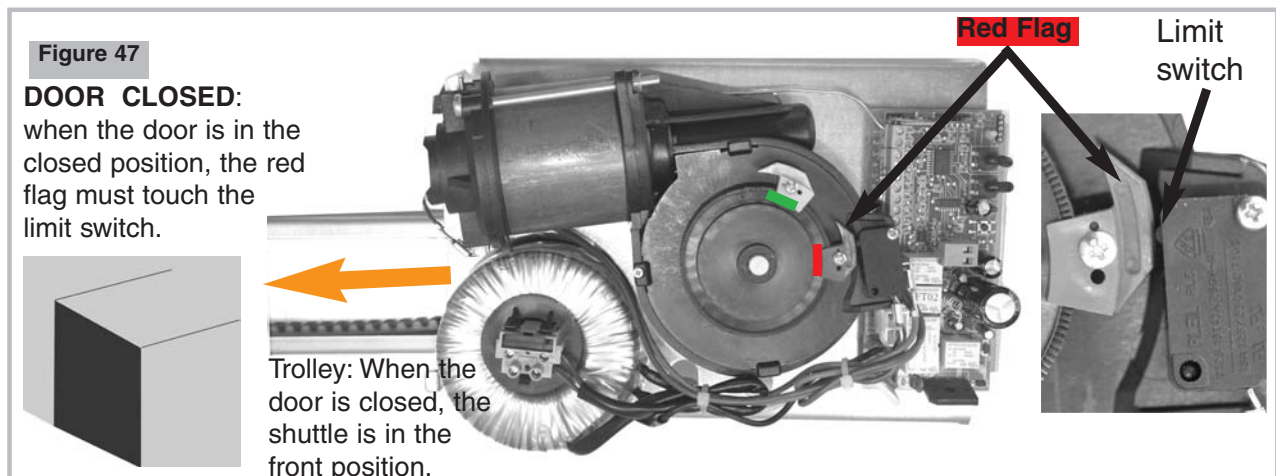

13. Automatic closing

Make adjustments and settings only with the garage door in closed position, and make sure no object or person is in the operating zone.

To activate the door's automatic closing program, rotate the "TIME" adjustment screw counter clockwise from 0 position, until the desired time pause interval is reached. The adjustment range is 0-100 sec. Your door will automatically close after the programmed pause interval.

Position = 0 (adjustment screw completely rotated clockwise) will activate the step-by-step function = opens - stops - closes.

A garage opener set in automatic closing function will not accept a remote control, keypad or key switch impulse while in pause mode.

WARNING:

If you set the opener to the automatic close function, you increase the risk of injury to people or damage to objects!



In order to prevent damage, never allow any object or car to be left in your door's movement zone. Never leave children unsupervised near the door if you have set the automatic closing function. AllDucks recommends using the step by step function.

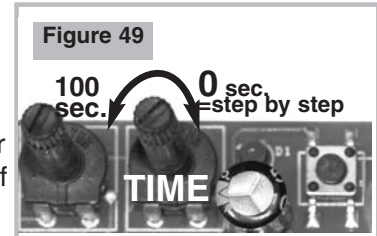

14. Maintenance

Courtesy light:

The courtesy light on the electronic panel can be replaced with the following model:

Halogen lamp 20V 24W

Remote control batteries:

The remote control batteries last about 2 years.

Batteries can be replaced with the following model:

12V type A23 - 5mA

Safety fuse:

In the event of short circuit, the safety fuse can be replaced with the following type: Fuse 5x20mm 1AT fast (see Figure 40, page 14)

15. Troubleshooting

1) Opener does not operate.

- Check the electric power supply.
- Check the safety fuse and, if necessary, replace it.
- Check motor function by triggering it through the start contact. (See illustration.)
- Check that the remote control code is stored in the opener board (erase the entire memory first and then store the code).
- The batteries could be discharged. Replace them.

2) The opener opens but does not close.

- If the photo beams are not connected, check that the bridge between outlets 4 and 5 is appropriately connected.
- If the photo beams are connected, check their alignment and that they are clean both inside and out.
- Also check that no automatic closing function has been programmed. Should this be the case, the system will not accept closing commands during pause time.

3) The system does not operate by remote control beyond a certain range.

- There may be interference in the air. An external aerial antenna is recommended.

4) The door does not close in the desired position.

- Check that there is no excessive friction at a specific door position. - Check the power level, and if necessary increase it.
- Check the limit switch settings.

16. Warranty & customer support

Allducks products are guaranteed for 12 months from the purchase date, for manufacturing or material defects. If repaired, the product shall be returned to one of our authorised customer service centres. The authorised technical assistance centres are the only facilities suitable to carry out warranty repairs. If you have a problem, or to reach the customer service offices of your country, please contact: **Allducks Srl Via Alessandro Volta, 1 - 20060 Ornago (MI) ITALY Tel. +39/039/6010654**

Fax +39/039/6011243 service@allducks.it / info@allducks.it www.allducks.it

Warranty conditions

1. The warranty is valid only with proof of purchase; no alteration or cancellation may be shown on the proof-of-purchase document.
2. Allducks is responsible only for repair or, at its own discretion, replacement of defective parts.
3. The product warranty shall immediately be void if the product has been modified or adapted to technical or safety norms different from those in force in the country for which the product was designed and manufactured.

No refund shall be provided for damages deriving from the above-mentioned modifications.

4. The warranty does not cover:

- a) Routine checks, maintenance, repairs or replacement of worn-out parts.
- b) Transport, handling or installation costs related to this product.
- c) Improper use, operator error or incorrect installation.
- d) Damage caused by fire, water, natural phenomena, storms, incorrect power supply, or any other cause beyond the manufacturer's control.

5. This warranty has no influence on the rights of the customer under applicable law, nor on the rights of the customer towards the reseller deriving from the purchase contract.

If no national laws apply, this guarantee shall be the only safeguard for the customer, and neither the manufacturer nor his distributor shall be responsible for accidental or indirect damage to their own products deriving from the infringement of warranty conditions.

UK HELP-LINE: 0845 136 2012

Mo-Fri: 0900-1900 Sat: 0900-1700 Sun: 1000-1600

17. Replacement parts

ATTACHMENT SET contents:

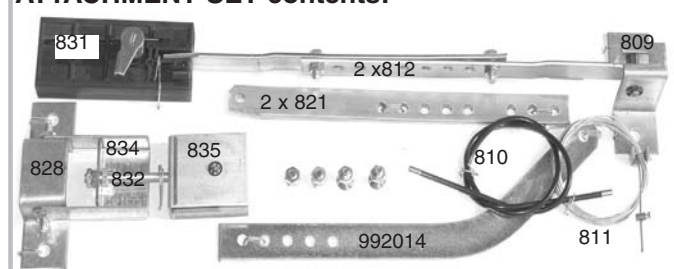

RAIL SET contents:

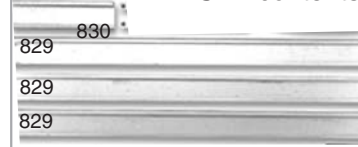

BELT SET contents:



8500T/ belt/ roll

Complete garage motor head with electronic panel, motor and transformer



R403 UE transformer 230V



826 belt pulley



CTH29S

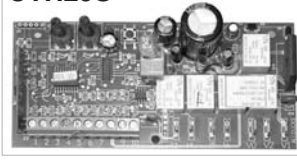

825/R117 complete motor



18. Optional accessories

Remote control
6203 rolling



key switch
SW5000



radio key pad
SW6500



wide angle
mirror
SW7950



photo beam
SW7012



external antenna
with 5 m cable
6025/5



Flasher
SW7500



Canopy arm
992012



How to order replacement parts or optional accessories:

Please contact your local store or Allducks national customer service centre, or Allducks to get more information on the services provided in your country. Note: Not all optional accessories or replacement parts are available at local stores.

If your distributor does not have some accessories, please contact www.allducks.it

19. CE declaration

DECLARATION OF CONFORMITY

WE

Allducks srl
Via Alessandro Volta,1
20060 Ornago (MB) ITALY

declare under our sole responsibility that the products listed below to which this declaration refers:

8500SF Garage Door Opener

when installed, used and maintained according to all the manufacturer instructions on a garage door which has also been installed correctly in accordance with all security and safety norms indicated by the manufacturer, are in conformity to the applicable sections of standards:

EMC: EN61 000-6-2, EN61 000-6-3, EN301 489-3,

EMF: EN50366, EN50371

SAFETY: EN60335-1 4th ed., EN60335-1:2002, EN60335-2-1 03:2003

En60335-2-1 03,

EN60529;

EN60950-1; EN60947-5-1, EN60598-2-1

ETS300683,

EN5501 4-1, EN5501 4-2:2001

EN60555,

EN1 3241,

EN 6100-3-2; EN6100-3-3

EN1 2453:2000

EN1 2445

Following the provisions of EU Directives and all amendments:

89/392/EEC, 99/05/CE, 73/23/CEE, 89/336/EEC, ENC300 220-3

and all of their amendments.

Remote control 6203 rolling,

Certificate No.: CE 0681

FCC ID OLS1 37925764

The above-mentioned items are in compliance with RoHS rules.

July 2008

The Chairman A. Toutberidze







6203/Rolling

Rolling coded remote control 433 Mhz



The rolling code remote 6203/ transmits a unique “rolling code” (billions of continuously changing combinations) on a frequency of 433 MHz. With 2 buttons, it has 3 transmission channels.

Channel 1 = press the ON button
Channel 2 = press the OFF button
Channel 3 = press the ON + OFF buttons together

To operate your DUCATI AUTOMATION opener with the 6203/rolling remote control, you must store the remote control code into the memory of your device’s circuit board using the simple procedure described in point A).

WARNING: Make adjustments and settings only with the garage door or gate in closed position.

A) To store the remote control code in the opener’s circuit board:

The door must be closed and idle.

- Press button P1 on the electronic panel. The red LED lights up.
- Release button P1 and immediately press the buttons of the remote control that you wish to use to operate the opener. Hold the remote button down for about 4 seconds.
- The green LED on the electronic panel (red LED for garage door openers) will blink rapidly. The red LED will go off after about 6 seconds.
- Press the stored remote control button again; the opener will begin to operate.

No more than 10 remote control codes can be stored on each of the opener’s electronic panels.

B) To erase codes from the control panel:

To deactivate any unwanted remote, first erase its memory from the electronic panel of your garage door opener as follows (all stored remote control codes will be deleted):

- The door must be closed and idle.
- Press button P1 for about 20 seconds until the red LED blinks.
- Then release P1.
- All remote control codes have been deleted.
- Reprogram each remote you wish to use.

Maintenance:

To change the battery, remove the screw on the back of the remote and open the cover. Use a 12V type A23-5mA battery.

NOTE: Also refer to your device instruction manual for specific instructions or functions.

DECLARATION OF CONFORMITY

WE

Allducks srl
Via Alessandro Volta,1
20060 Ornago (MB) ITALY

declare under our sole responsibility that the products listed below to which this declaration refers:

6203/rolling Rolling coded Remote control 433Mhz

when installed, used and maintained according to all the manufacturer's instructions, conform to the applicable sections of CE-EN standards and all of their amendments:

ETS 300 683

EN300 220-1

ETSIEN301 489-3

EN300 220-3

EMC: EN61 000-6-2, EN61 000-6-3, EN301 489-3,
Directive 99/05/EC

Remote control 6203/rolling,

Certificate No.: CE 0681

FCC ID OLS1 37925764

The items mentioned are in compliance with RoHS rules.

Territory of use:

For use in all listed CENELEC member countries as indicated in standard EN 60950.

July 2008

Chairman

A.Toutberidze



UK HELP-LINE:

0845 136 2012

Mo-Fri: 0900-1900

Sat: 0900-1700

Sun:1000-1600

Manufactured by:

Allducks srl

via Alessandro Volta, 1 20060 Ornago (MI) Italy Ph. +39/039/6010654 Fax +39/039/6011243
service@allducks.it www.allducks.it

