

3. POSITIONING THE LOCK

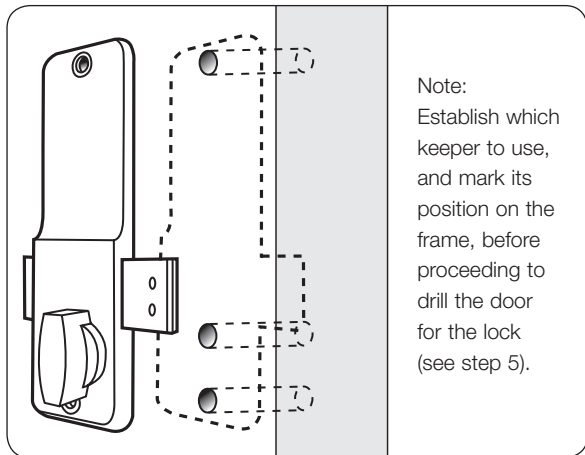

- Remove the inside cover plate from the back plate, and install the deadbolt according to the hand of your door. Note that the standard bolt projects 40mm to the locking side. A shorter bolt which projects 20mm is available.
- Set the back plate with the knob in the vertical position and hold it to the door with one end of the bolt against the frame where the keeper will be fitted (see step 5).
- Mark the position of the top fixing hole, and then using one of the packing pieces as a template mark the position of the lower fixing hole and the hole for the spindle. Drill 8mm holes for fixing bolts and 13mm hole for spindle.

4. FIXING THE LOCK

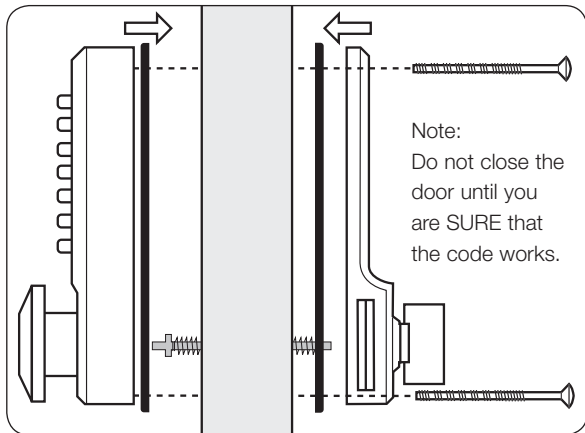

- The spring loaded spindle will fit doors between 35mm and 65mm thick. For doors less than 50mm thick break off the 15mm section at the end of the spindle. For doors more than 65mm thick ring the helpline for advice. The spring keeps the spindle firmly engaged in the outside handle when the lock is assembled on the door.
- Cut the fixing bolts to suit the door thickness, allowing for the rubber seals and at least one threaded section to screw into the lock case.
Note that the bottom fixing bolt will be longer than the top.
- Hold the lock case and the back plate, with the neoprene seals in place, onto the door with the spindle in position. Using the top fixing bolt first screw everything together.

5. FITTING THE KEEPER

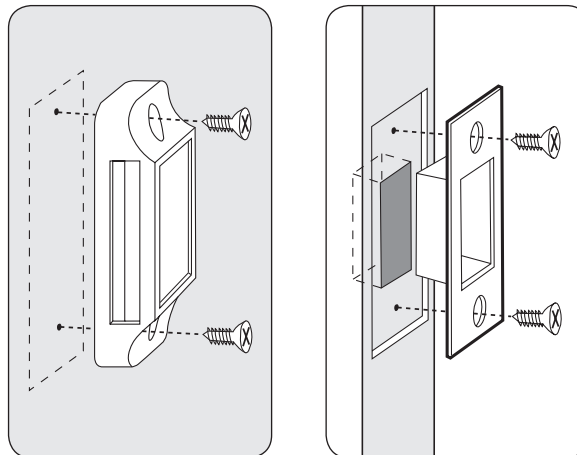

Surface Keeper
fig. 5.1

Mortice Keeper
fig. 5.2

- First select the appropriate keeper for your frame.
- Position the keeper on the frame so that it lines up with the deadbolt and mark the appropriate holes.
- If you are using the Surface Keeper simply screw into place (see fig. 5.1). Use the packing pieces as required.
- The Mortice Keeper will require cutting a small recess (see fig. 5.2).

11-120105D-V02

CODELOCKS
control + convenience

INSTALLATION INSTRUCTIONS

**CODELOCK
100
MECHANICAL**

**CODELOCK
200
MECHANICAL**

Surface Deadbolts & Key Override Versions

Helpline, service & spares
FREEPHONE 0800 393 405

CODELOCKS LTD
Tel 01635 239645
Fax 01635 239644
sales@codelocks.co.uk
www.codelocks.com



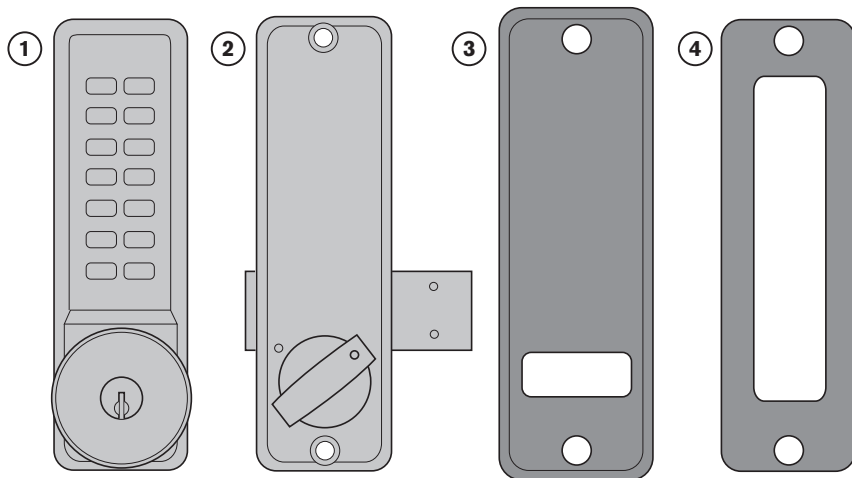

1. Front plate – key override option shown
2. Back plate – bolt is packed separately
3. Neoprene seals x2
4. Packing pieces x2 (for back plate only)
5. Spring loaded spindle
6. Mortice keeper
7. Surface keeper
8. Surface keeper packing pieces x1
9. Wood screws x2 (to use with keeper)
10. Tweezers
11. Fixing bolts 3 supplied (spare x1)
12. Tumblers (spare x2)
13. Code card
14. 2 keys – key override options only

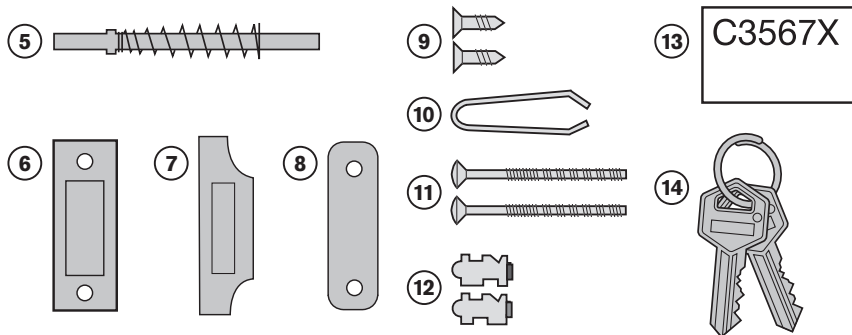

Tools required for installation

- Power drill
- 8mm & 13mm drill bits
- Bradawl
- Philips screw driver size 2
- Chisel (maximum 15mm)
- Hammer/Mallet
- Stanley knife
- Pencil
- Tape measure

Before commencing installation check that all parts are working correctly. Press the code according to the code card and the knob should then turn, in either direction, once only, and return easily under spring pressure. From inside the door the bolt can be freely locked and unlocked using the knob. From outside the code is required both to lock and to unlock the bolt. If you would like to be able to **LOCK** your door from outside **WITHOUT** using the code then follow instruction 2.

- If you intend to change the code then, if it is convenient, you should do it before installing the lock. See the code change instructions in the separate leaflet.

- Note that the lock is supplied as standard with a bolt which projects 40mm from the side of the lock. A shorter bolt which projects 20mm is available.

1. CHECK THE HAND OF YOUR DOOR

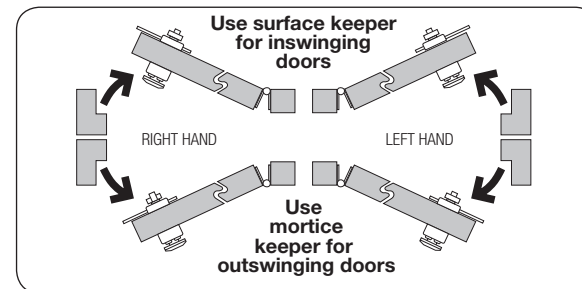

- Your door is right-handed if, viewed from outside, the hinges are on the right.

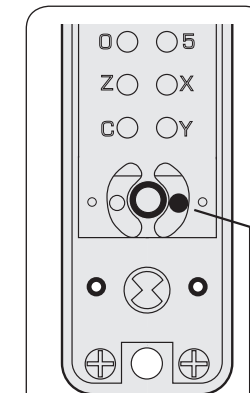

Leave this pin for left handed doors

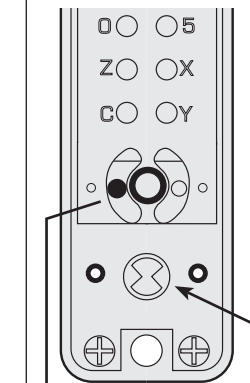

Leave this pin for right handed doors

To enable LOCKING of the bolt from outside WITHOUT using the code:

- Press the C button to reset the chamber and place the lock case on a flat surface with the buttons down.

- Remove the code chamber plate held in place with the two red screws.

- With the tweezers remove the right-hand pin for right-handed doors, or the left-hand pin for left-handed doors.

- Replace the cover plate.

- The outside knob will now feel loose and turn freely in one direction, and will require the code to be used before it will turn in the other direction.

- NB** When installing the lock make sure that the driver is in the correct position before installing the spindle.

code change instructions

STAYING IN CONTROL HAS NEVER BEEN EASIER

CL100 and CL200 locks can be used at home on doors, garages and garden sheds, and at work in offices, workshops and storerooms requiring restricted access. Available in Silver Grey, Polished Brass and Stainless Steel.

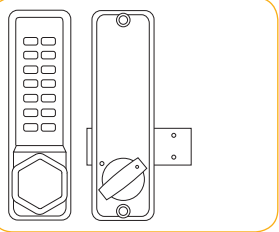

■ Surface deadbolt

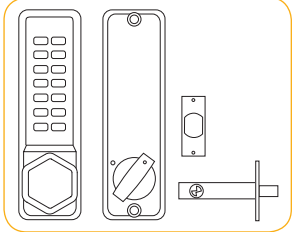

■ Mortice deadbolt

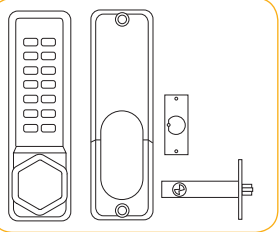

■ Mortice latch

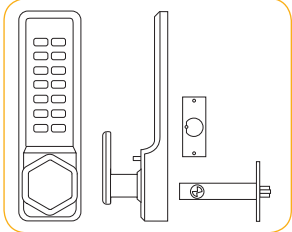

■ Mortice latch with hold-open feature

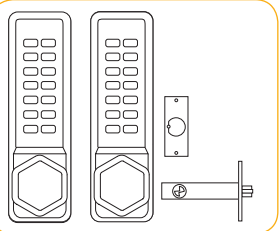

■ Back to back mortice latch

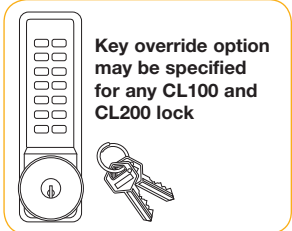

■ Key override option may be specified for any CL100 and CL200 lock

■ Key override option

MANY CODES TO CHOOSE FROM

The CL100 and CL200 code chamber consists of 13 buttons from which the code is selected, and a 'C' button which is used to re-set the chamber after an incorrect entry, and which must always be used as the first digit of a code. Buttons may only be used ONCE in a code. For example, 1212 is not possible.

A CL100 and CL200 code, or combination, can be entered in any order or sequence; eg 1234 can be 4321 or 1342 or whatever sequence is most convenient to remember.

With 13 buttons, a total of 8,191 **different** codes are available, any of which can be entered in any sequence.

The total is arrived at as follows:

'C' plus 1 digit	= 13	'C' plus 6 digits	= 1716	'C' plus 11 digits	= 78
" 2 "	= 78	" 7 "	= 1716	" 12 "	= 13
" 3 "	= 286	" 8 "	= 1287	" 13 "	= 1
" 4 "	= 715	" 9 "	= 715	Total = 8191	
" 5 "	= 1287	" 10 "	= 286		

Most people will set a code in the range of 4 to 7 digits, and the total number of codes in this range is 5434.

The lock is factory set with a randomly selected 6 digit code starting with the C button. The code is not recorded by the factory. The code can be changed as often as required to any other 6 digit code. Every new code must start with the C button. Using the spare tumblers, one red and one blue, the code length can be changed to 5 or 7 digits. Shorter codes are not recommended.

1. Take your CL100 or CL200 lock off the door by unscrewing the 2 screws in the backplate.
2. Press the C button to reset the chamber and place the lock case on a flat surface with the buttons down.
3. Remove the 2 red screws and carefully lift off the code chamber plate. Check that all 14 springs are held in place on the plate.
4. Note that the red tipped code tumblers correspond in position to the existing code. The blue tipped non-code tumblers fill the other positions. The C tumbler is not coloured.
5. Hold the lock in your hand and depress the C button. Keeping the C button depressed use tweezers to re-position the tumblers to correspond with your new code. The square notches of ALL tumblers MUST face outwards, with the coloured tips ON TOP: See diagram below. DO NOT force the tumblers in.

NB: Holding the C button depressed whilst re-positioning the tumblers is ESSENTIAL to avoid damaging the internal mechanism. DO NOT attempt to reposition the C tumbler.

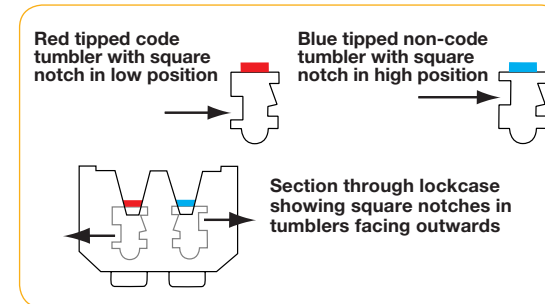

6. Replace the code chamber plate carefully with the 2 red screws.
7. Check the operation of the new code, and make a written note of it before re-installing the lock.
8. Insert the spindle, with the spring on the code side. On latchbolt locks the spindle must engage the latch as follows:

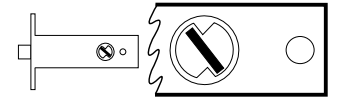

Door hung on right viewed from outside

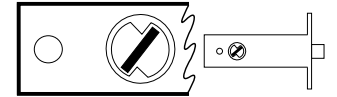

Door hung on left viewed from outside

MAINTENANCE

No maintenance of the working parts is necessary.

DO NOT OIL. To maintain the finish the lock should be cleaned regularly with a soft cloth. A silicone spray or similar, should be used to provide a protective film against grit and grime.

GUARANTEE

If any CL100 or CL200 lock should develop a fault, at any time due to manufacture, just call the Helpline and arrange for it to be repaired free of charge.

trouble shooting guide

PROBLEM AND PROBABLE CAUSE

On latch locks only. The outside knob and inside handle retract the latch when turned TOWARDS the door frame.
The spindle is positioned at the wrong angle.

The knob will not turn after entering the original code.
The code does not match the card.

The knob will not turn after entering a newly changed code.
One or more of the code tumblers are the wrong way around.

The latch bolt does not move smoothly in and out.
The lock is installed incorrectly.

The inside and outside knobs do not return easily to the centre position after use.
The spindle is too long for the door thickness.

The inside handle does not retract the latch.
The spindle is too short for the door thickness.

The inside lever handle does not return to the upright position after operating.
The lever return spring is broken.

The latch does not engage and so the door remains unlocked after use.
The latch is not entering the strike.

ACTION

Refer to the code change instructions overleaf. Remove the lock from the door and reposition the spindle as shown in the instructions. On hold-open locks ensure that the blue handing screw on the lever handle plate is in the correct hole.

Remove the lock from the door, turn the lock case upside down and check that the red tumblers correspond with the code on the card.
NB: the 'C' tumbler is not coloured - but MUST start every code.

Re-read the code change instruction and check that the square notches on the tumblers face to the outside edge of the lock with the coloured tips on top.

Check that the lock is square on the door and positioned accurately over the latch. Check that the latch is positioned horizontally and parallel to the door surfaces.

The spindle must not project more than 30mm into the inside handle. If it does then it will be trapped between the front and back handles and prevent them moving easily. The spindle must be shortened.

The spindle must project from the inside face of the door by at least 8mm so as to engage the handle. The spindle may have been cut too short during installation. Call the **Helpline** to obtain a longer spindle.

Call the **Helpline** for a replacement spring, **free of charge**.

Your door or frame may have warped since the lock was installed. Check that the latchbolt is lined up with the strike aperture and adjust the position of the strike as necessary. Make sure the deadlocking plunger cannot enter the strike aperture alongside the latch bolt when the door is closed.

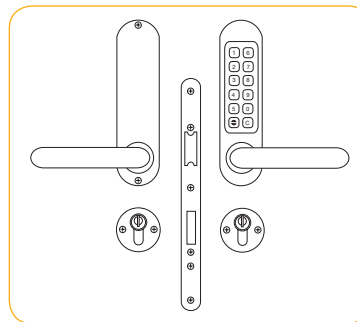

■ 500 series

The **500** series mechanical lock should be specified for doors requiring full-size lever handles, passage set operation during normal working hours, and code lock-out by deadbolt (525 model only). The key can be used by security and cleaning staff to retract the latch as well as the deadbolt without using a code. The inside lever handle will always retract the deadbolt of the 525 model, thus avoiding accidental lock-ins and meeting safety regulations.

For full information on all mechanical and electronic locks in our range visit www.codelocks.com

CODELOCKS LTD
Tel 01635 239645
Fax 01635 239644
sales@codelocks.co.uk
www.codelocks.com
Helpline, service & spares
FREEPHONE 0800 393 405

CODELOCKS
control + convenience

CC-1/200-V02

CODELOCKS
control + convenience

CODELOCK
100
MECHANICAL

CODELOCK
200
MECHANICAL



**CODE CHANGE
INSTRUCTIONS
& TROUBLE
SHOOTING GUIDE**