

TITAN®

GB-IE

TITAN Power Tools (UK)Ltd.
Trade House, Mead Avenue,
BA22 8RT

Submersible Pump

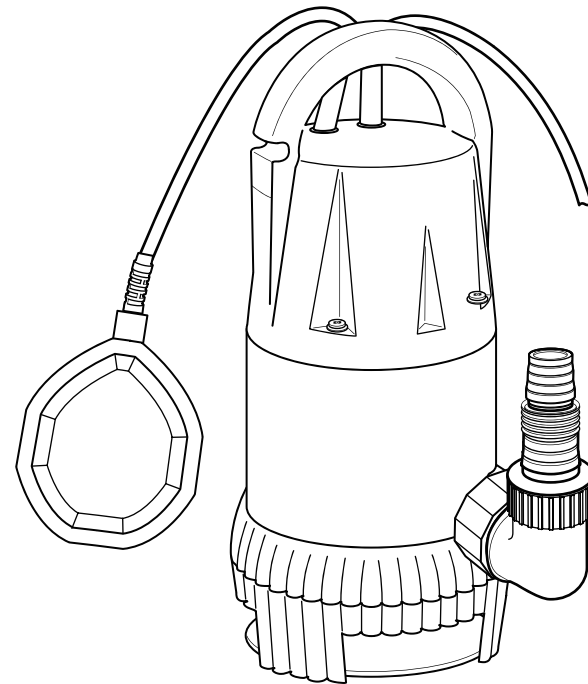

Original Instructions_DFT_TTB582PMP(XKS-751PW)_V1_131114

TTB582PMP

Barcode: 01045598

Ref. No.: 55753

WARNING: Read the instructions before using the product!



TITAN®

Congratulations on your purchase of TITAN, a power tool from Titan Power Tools (UK) Ltd. We want you to continue getting the best performance from it so this handbook includes information on safety, handling and care. Please retain this handbook in case you need to refer to any of the information in the future.

Your TITAN power tool comes with a 2 years guarantee, so should it develop a fault within this period contact your retailer.

GARANTIE

This **TITAN** product carries a guarantee of 2 years. If your product develops a fault within this period, you should in the first instance contact the retailer where the item was purchased.

This guarantee specifically excludes losses caused due to:

- Fair wear and tear
- Misuse or abuse
- Lack of routine maintenance
- Failure of consumable items (such as batteries)
- Accidental damage
- Cosmetic damage
- Failure to follow manufacturer's guidelines
- Loss of use of the goods

This guarantee does not affect your statutory rights. This guarantee is only valid in the UK.

For any enquiries relating to the guarantee please refer to your retailer.

Let's get started...

These instructions are for your safety. Please read through them thoroughly before use and retain them for future reference.



Getting started...

03

Safety information 04
Your product 09
Before you start 10



In more detail...

15

Product functions 16
Operation 18
Care and maintenance 20
Trouble shooting 24
Recycling and disposal 25
EC declaration of conformity 26

Submersible Pump TTB582PMP

Safety warnings

- >This product can be used by children aged from 8 years and above and persons with reduced physical, sensory or mental capabilities or lack of experience and knowledge if they have been given supervision or instruction concerning use of the product in a safe way and understand the hazards involved.
- >Children should be supervised to ensure that they do not play with the product. Cleaning and user maintenance shall not be made by children without supervision.
- >If the power cord is damaged, it must be replaced by the manufacturer, its service agent or similarly qualified persons in order to avoid a safety hazard.

Pump safety warnings

- >This product is to be supplied through a residual current device (RCD) having a rated residual operating current not exceeding 30 mA.
- >Prevent access of children with appropriate measures.
- >Do not use when people are in the water.
- >Do not operate the pump without water.
- >Make sure that no marine animals (e.g. fish)

- are extracted by the product.
- >Have in mind that pollution of the liquid could occur due to leakage of lubricants.
- >Protect the electrical connections and cords from heat, oil, sharp edges and moisture.
- >Protect the product from frost and running dry.
- >Avoid circulation of aggressive fluids of abrasive materials.
- >Do not use the power cord or the float switch cable to transport or secure the product. Fix a rope to the handle for submerging, lifting or securing
- >Check and clean the outlet and the inlet of the pump when needed.
- >Do not pump liquids with sand or other abrasive substances. It causes increased wear and reduces the pumps output.
- >The product is designed for clear water with a diameter of suspended impurities not exceeded 30mm.
- >The product should be used for pumping water temperature below 35°C, do not use the product for other liquids (hydrocarbons, oils, corrosive liquids, flammable liquids...).
- >Never use the product in case of danger of frost.
- >The product is not designed for continuous

Safety warnings

use. Please rest it for 10 min after each 1 hour running.

General safety warnings

- >Familiarise yourself with the operation, adjustments and functions. Internalise and follow the safety and operation instructions in order to avoid possible risks and hazards.
- >Contact a qualified person or your dealer if you have questions after reading the instruction manual.
- >Store the instruction manual so that it is accessible for all users. Also relay it when giving the product to others.
- >Do not attempt to modify the product in any way. Only use attachments and accessories recommended by the manufacturer.
- >Use the product only in accordance with this instruction manual. Misuse and incorrect handling will lead to hazards for people and property.
- >Do not use the product if damage is visible. Check the power cord, plug, attached hoses and casing before each use. Faulty products must be repaired or properly disposed of.
- >Disconnect the product from the power supply immediately if the cord or the product

supply immediately if the cord or the product is damaged or if a breakdown occurs.

- >Have the product repaired only by a qualified specialist. Improper repairs can lead to electric shocks or other accidents.
- >Pull the plug rather than the power cord to disconnect the product from the power supply.
- >Do not let the power cord hang over edges, do not squeeze or bend it.
- >Use extension cords that correspond with the technical requirements of this product if using an extension cord is unavoidable. When operating products outdoors, use an extension cord suitable for outdoor use.

Symbols

On the product, the rating label and within these instructions you will find among others the following symbols and abbreviations. Familiarize yourself with them to reduce hazards like personal injuries and damage to property.

V~	Volt, (alternating voltage)	l	Litre
W	Watt	l/h	Litre per hour
Hz	Hertz	kg	Kilogram
m	Metre	°C	Degree Celsius
mm	Millimetre		

IPX8 The protection degree indicates that the product is suitable for continuous immersion in water.

yyWxx Manufacturing date code: Year of manufacturing (20yy) and week of manufacturing (Wxx)

 Lock / to tighten or secure

 Unlock / to loosen

 Caution / Warning.

 Read the instruction manual.

 Disconnect the product from the power supply before assembly, cleaning, adjustments, maintenance, storage and transportation.

 The product complies with the applicable European directives and an evaluation method of conformity for these directives was done.

 WEEE symbol. Waste electrical products should not be disposed of with household waste. Please recycle where facilities exist. Check with your Local Authority or local store for recycling advice.

 Max. delivery rate

 Max. particle size

 Total head

 Max. operating depth

Your product

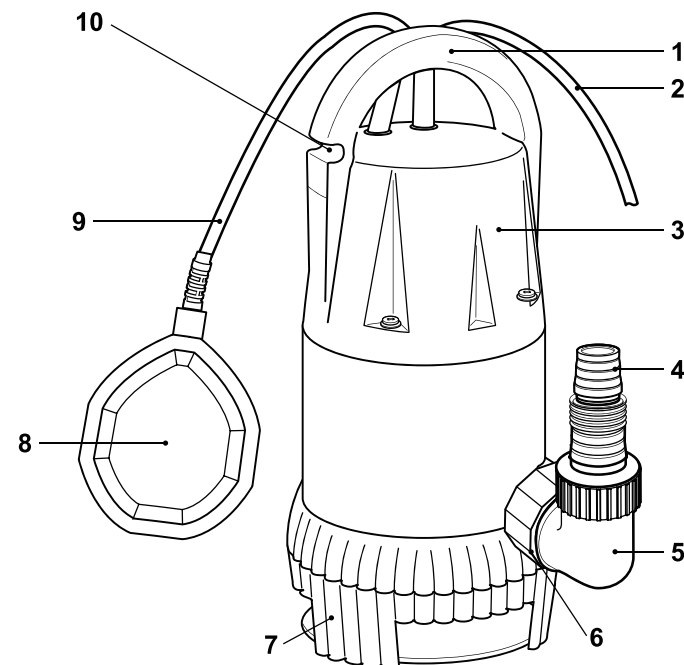

1. Handle
2. Power cord with plug
3. Housing
4. Connector
5. Adaptor
6. Outlet nozzle
7. Base
 - a. Impeller*
 - b. Rubber gasket*
 - d. Screw (long)*
 - e. Base plate*
 - f. Screw (short)*
8. Float switch
9. Float switch cable
10. Clip



NOTE: Parts marked with * are not shown in this overview. Please refer to the respective section in the instruction manual.

Technical specifications

- > **Rated voltage** : 220 – 240 V~ | 50 Hz
- > **Rated input power** : 750 W
- > **Delivery rate Q_{max}** : 13500 l/h
- > **Total head H_{max}** : max. 8 m
- > **Operating depth $\frac{\nabla}{...m}$** : max. 7 m
- > **Water temperature** : max. 35 °C
- > **Max. particle size** : Ø 30mm
- > **Protection class** : |
- > **Degree of protection** : IPX8
- > **Net weight (assembled)** : approx. 5.9 kg
- > **Outlet nozzle** : Ø 25 mm (outer thread) for connector
Ø 38 mm (outer thread) for adaptor
- > **Length of power cord** : 10 m

Unpacking

- > Unpack all parts and lay them on a flat, stable surface.
- > Remove all packing materials and shipping devices, if applicable.
- > Make sure the delivery contents are complete and free of any damage. If you find that parts are missing or show damage do not use the product but contact your dealer. Using an incomplete or damaged product represents a hazard to people and property.
- > Ensure that you have all the accessories and tools needed for assembly and operation. This also includes suitable personal protective equipment.

You will need

(items not supplied)

suitable water hose or pipe including connector/adaptor rope
suitable backflow preventer with filter
suitable gate valve
fixation material for installation

(items supplied)

Connector (4)
Adaptor (5)



NOTE: The needed accessories depend on the intended application. Ask your dealer for advice.

Installation



WARNING! The product must be fully installed before operation! Do not use a product that is only partly installed or installed with damaged parts!
Follow the installation instructions step-by-step and use the pictures provided as a visual guide!
Do not connect the product to power supply before it is completely installed!

Accessories

- > Only use accessories that fulfil the requirements of this product. Pay special attention to the diameter of hoses / pipes, adaptors and connectors.
- > We recommend the use of quick-release fasteners on the appropriate place to quickly separate the product for cleaning and/or maintenance work (or for wintering) from the hose / pipeline system.
- > Ensure that connectors and adapters are fitted with gaskets rings and fasten them only hand tight.

Hose / pipe system

- > Install hoses / pipes in such a way that they do not exert any mechanical pressure on the product.
- > Secure hose / pipe in such a way as to prevent any oscillation, friction or weight impacting on the product.
- > Lay the hose / pipe in as short and straight as possible. Avoid an excessive number of bends.
- > Choose a reinforced delivery hose / pipe of the same or larger diameter as the outlet nozzle in order to reduce friction loss.

Installation

Follow below instructions depending on the required operation

- > Screw the connector (4) clockwise onto the adaptor if it is not already pre-assembled (Fig. 1).
- > Screw the adaptor (5) to the outlet nozzle (6) (Fig. 2). Tighten it properly.
- > Attach a suitable hose / pipe to the connector (4) and secure it with suitable fixation material (Fig. 3).

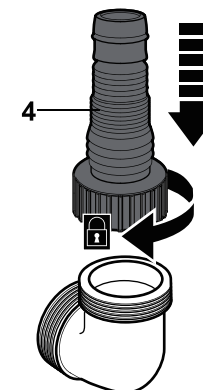

Fig. 1

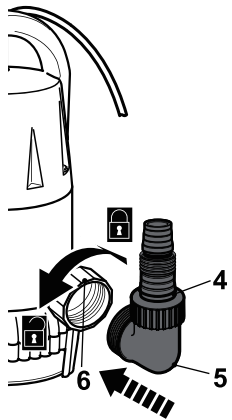

Fig. 2

> Fasten a rope (not provided) to the handle (1) and submerge the product carefully into the water reservoir (Fig. 4)

> Lift the pump by a rope (not provided) from the water reservoir after use.

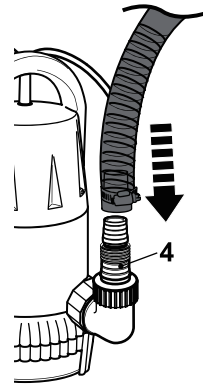

Fig. 3

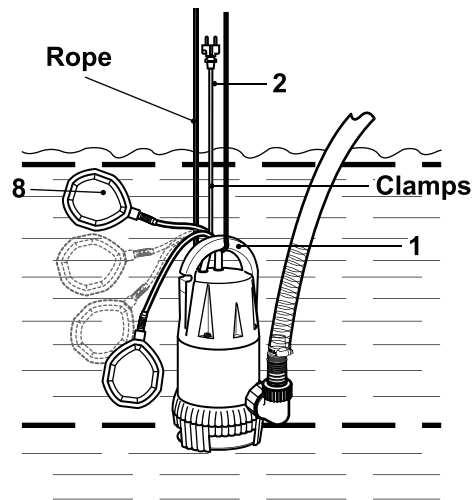

Fig. 4



WARNING: Do not lift the pump by power cord.



NOTE: Ensure the water reservoir has minimum dimensions of 40 x 40 x 50 cm, so that the float switch (8) can move freely.



NOTE: We recommend guiding the power cord by means of clamps alongside the fastening rope (Fig. 4).

Connection to power supply



NOTE: Ask a qualified electrician to ensure that the protective earth conductor and RCD correspond with the local safety regulations and work faultlessly before connecting the product to the power supply.



WARNING! You must test the RCD device before every use as described below.

Do NOT use this product when there is a failure in the above mentioned process test.

Make sure the float switch (8) is in its upper position.
Connect the plug (2) with a suitable socket.
Press the **“RESET”** button. The indicator light will turn on.
Press the **“TEST”** button. The indicator light should turn off.
Press the **“RESET”** button to restart.
Your product is now ready to be used.

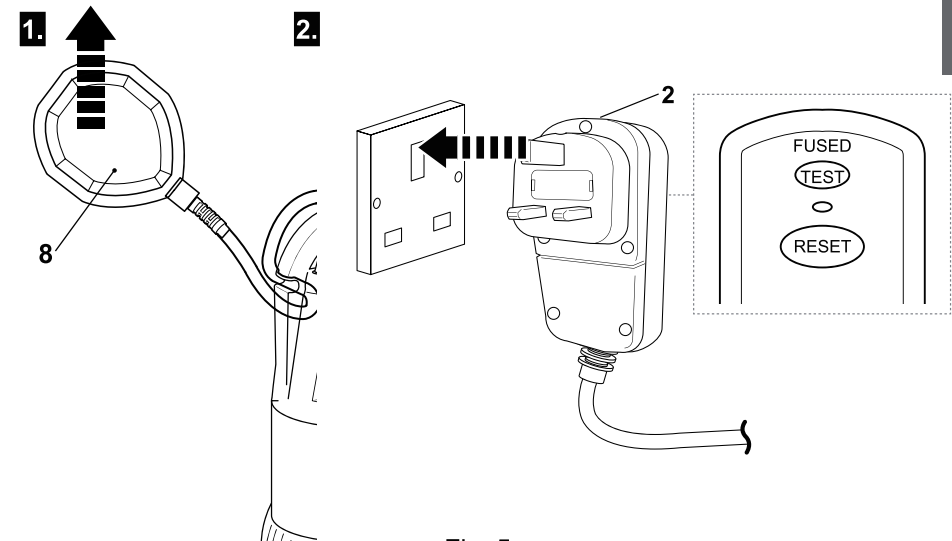

Fig. 5



WARNING! Check the voltage! The voltage must comply with the information on the rating label!



In more detail...

Product functions	16
Operation	18
Care and maintenance	20
Trouble shooting	24
Recycling and disposal	25
EC declaration of conformity	26

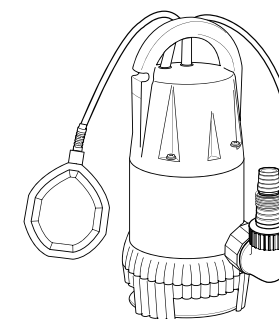

Intended use

This submersible pump TTB582PMP is designated with a rated input power of 750 Watts and is intended for the circulation of water with a maximum temperature of 35 °C.

With suitable accessories the product can be used for draining when flooding occurs in rooms and also for pumping over to or pumping out of water containers, to remove water from wells and shafts, for draining boats and yachts. The product can be fully submerged (watertight encapsulation) and lowered to a water depth of 7 m.

The product is not suitable for long term circulatory use (e.g. in a pond, swimming pool, aquarium). The product is used for water with PH between 6.5 and 8.5, and may not be used for other fluids, especially corrosive, flammable or explosive substances and other chemical products.

For safety reasons it is essential to read the entire instruction manual before first operation and to observe all the instructions therein.

This product is intended for private use only, not for any commercial trade use. It must not be used for any purposes other than those described.

Float switch

This product works with automatic interval operation. The float switch (8) swims on the surface of the water or alternatively under water. The product switches on or off according to position of the float switch (8). In this way, you can automatically control the water level e.g. in wells or containers.

i **NOTE:** The float switch contains a ball that activates a switch. The product works only if the float switch is above position A, position B corresponds to the switch off level of the pump (Fig. 5).

The product is started at a certain water level by the float switch (8) (switch on level) (Fig. 6, A). The product continues pumping until the water level is lowered to a particular height and then the float switch turns the product off (switch off level) (Fig. 6, B).

> Adjust the height of the relative switch on and off levels within certain parameters by lengthening or shortening the free cable length of the float switch cable (9). Fix the float switch cable (9) to the clip (10) (Fig. 7).

i **NOTE:** Make sure the cable length is not less than 50mm between float switch and clip.

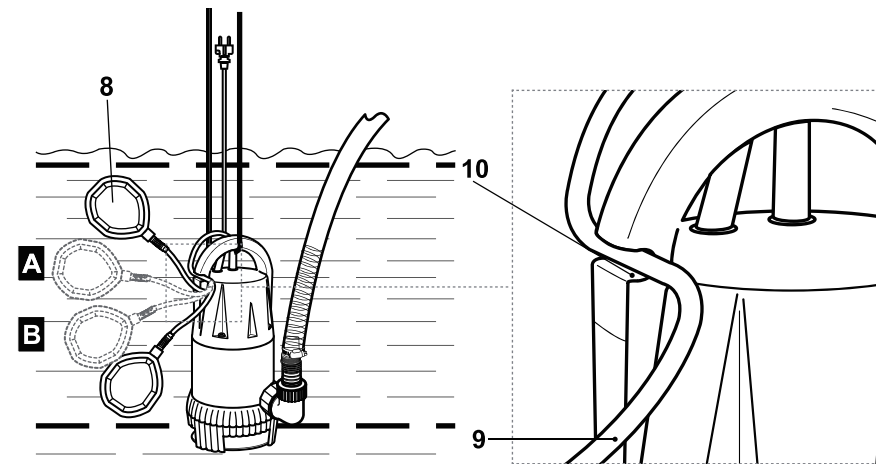

Fig. 6

Fig. 7

i **NOTE:** Before first use you should briefly familiarise yourself with the automatic controls of the float switch. Move the float switch up and down with your hand to simulate switching on and off. Alter the free cable length, until you have found a suitable extend to your purpose. Check out how the free cable length influences the switch on and off level (and ultimately the water level).

> Always make sure that the float switch (8) is free and unblocked when in the water to prevent the dry running.

i **NOTE:** Make sure the base can freely draw water and is free of mud, when lowering the pump to the ground of the water source.

Thermal protection

The product is equipped with a thermal cut-out. In the event that the motor becomes overheated due to an over-load operation such as clogged intake or low or no water, the thermal cut-out automatically switches the product off. After a cooling period the product automatically switches on again.

- > Disconnect the product from the power supply in case the thermal protection is activated.
- > Inspect the product for possible damage, wear or foreign objects that e.g. block impeller.
- > Eliminate the cause prior to re-starting the product (see "Troubleshooting").



NOTE: Should the thermal protection continuously be activated even after following the steps under "Troubleshooting" do not longer use the product. Have it checked and repaired by a qualified specialist.

Automatic air bleed valve

The automatic air bleed valve releases any air pockets in the pump body. During this process, air escapes through the ventilation bore on the pump and air bubbles appear underwater. It may take several seconds when the pump is immersed for the first time.

General operation

- > Check the product, its power cord and plug (2), the float switch cable (9) as well as accessories for damage before each use. Do not use the product if it is damaged or shows wear.



NOTE: The product must be fully immersed into the water. Otherwise the product cannot prime and the maximum constant flow will not be achieved. The product could be damaged!
To have an automatic start the pump must be submerged in a water reservoir with a minimum water level of 60 cm. If the water level is any less, the pump may not suck properly and there is a risk of dry running.

- > Double check that the accessories are properly fixed.
- > Connect the plug (2) with a suitable socket to switch the product on

Automatic operation

Connect the product to the power supply. The product is switched on automatically at a certain water level (switch on level) and switches off as soon as the water level drops down to a definite water height (switch off level).



NOTE: We recommend disconnecting the product from the power supply when you are not able to perform inspection over a longer period of time.

Manual operation



NOTE: This product can be used to suck up water with a lower height (90mm: depending on the pump) but must be manually operated the float.

- > Put the pump into water.
- > Connect the product to the power supply.
- > Lift the float switch (8) to start the product.



NOTE: If the water is not pumped after 20 seconds of starting, lower the float switch and lift the pump. Wait until the pump is emptied. Immerse the whole pump in water. If the product does not pump after several attempts, the water level is too low to seal the system.

- If the product does not pump after several attempts, the water level is too low to seal the system.
- > Lower the float switch (8) to stop the product.

After use

- > Disconnect the product from the power supply and let it cool down.
- > Check, clean and store the product and its accessories as described below.

The golden rules for care



WARNING! Always disconnect the product from power supply and let it cool down before performing inspection, maintenance and cleaning work!



- > Keep the product clean. Remove debris from it after each use and before storage.
- > Regular and proper cleaning will help ensure safe use and prolong the life of the product.
- > Inspect the product before each use for worn and damaged parts. Do not operate it if you find broken and worn parts.



WARNING! Only perform repairs and maintenance work according to these instructions! All further works must be performed by a qualified specialist!

Cleaning

- > Clean the product with a damp cloth and pH-neutral soap. Use a brush for areas that are hard to reach.
- > Remove stubborn dirt with high pressure air (max. 3 bar).



NOTE: Do not use chemical, alkaline, abrasive or other aggressive detergents or disinfectants to clean this product as they might be harmful to its surfaces.

- > Check for worn or damaged parts. Replace worn parts as necessary or contact an authorised service centre for repair before using the product again.
- > Regularly check for obvious defects such as loose, dislodged or damaged hoses, loose fixings and worn or damaged components.

Maintenance

Before and after each use, check the product and attachments (such as hoses, clips etc.) for wear and damage. If required, exchange them for new ones as described in this instruction manual. Observe the technical requirements.

Impeller

If excessive deposits collect in the base, dismantle the base and base plate of the product and clean the components (Fig. 8).

- > Loosen the screws (7d, 7f) counter clockwise with a proper cross-head screwdriver and remove them together with the base (7) and the base plate (7e).
- > Remove the rubber gasket (7b).
- > Clean the impeller (7a) with clean water.
- > Clean the base (7), the base plate (7e), the rubber gasket (7b) and the housing (3) if needed.
- > Assemble the product in reverse order.

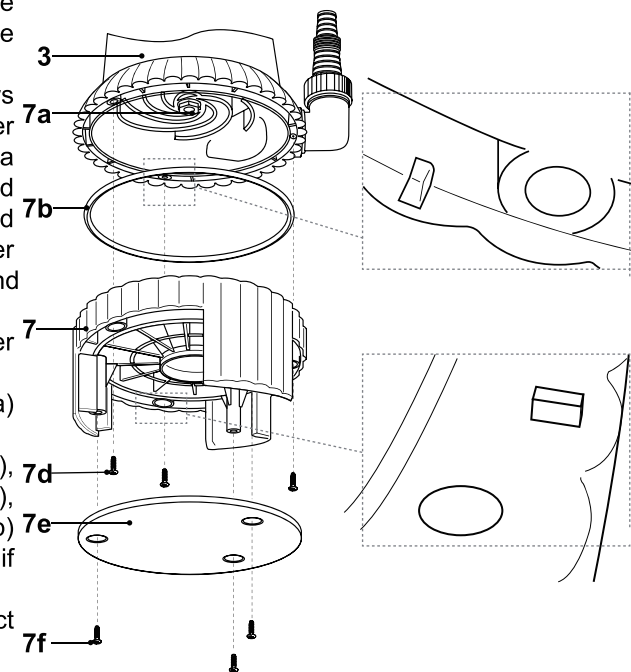

Fig. 8

Power Cord

If the power cord is damaged, it must be replaced by the manufacturer, its service agent or similarly qualified persons in order to avoid a safety hazard.

RCD with UK plug

If you need to replace the fitted plug, then follow the instructions below .
IMPORTANT: The wires in the mains lead are coloured in accordance with the following code:

Blue – Neutral Brown – Live

As the colours of the wire in the mains lead of this product may not correspond with the coloured marking identifying the terminals in your plug, proceed as follows. The wire, which is coloured blue, must be connected to the terminal, which is marked with N or coloured black. The wire, which is coloured brown, must be connected to the terminal, which is marked L or coloured red.

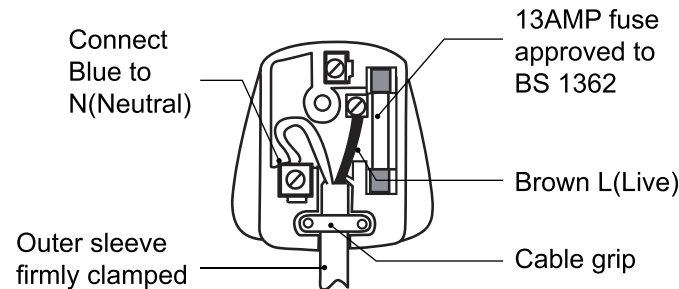

WARNING! Never connect live or neutral wires to the earth terminal of the plug.

Only fit an approved 13 Amp BS 1363 or BS 1363/A plug and the correctly rated fuse.

If in doubt, consult a qualified electrician.



NOTE: If a moulded plug is fitted and has to be removed take great care in disposing of the plug and severed cable, it must be destroyed to prevent engaging into a socket.

Repair

This product does not contain any parts that can be repaired by the consumer. Contact an authorised service centre or a similarly qualified person to have it checked and repaired.

Storage

- > Disconnect the product from the power supply.
- > Open all valves to release remaining water from the hose / pipe system.
- > Disconnect the product from the hose / pipe system
- > Clean the product as described above.
- > Store the product and its accessories in a dark, dry, frost-free, well-ventilated place.
- > Always store the product in a place that is inaccessible to children. The ideal storage temperature is between 10°C and 30°C.
- > We recommend using the original package for storage or covering the product with a suitable cloth or enclosure to protect it against dust.

Transportation

- > Disconnect the product from the power supply.
- > Always carry the product by its handle (1).
- > Protect the product from any heavy impact or strong vibrations which may occur during transportation in vehicles.
- > Secure the product to prevent it from slipping or falling over.

Troubleshooting

Suspected malfunctions are often due to causes that the users can fix themselves. Therefore check the product using this section. In most cases the problem can be solved quickly.



WARNING! Only perform the steps described within these instructions! All further inspection, maintenance and repair work must be performed by an authorised service centre or a similarly qualified specialist if you cannot solve the problem yourself!

Problem	Possible cause	Solution
1. Product does not start	1.1. Power supply not connected	1.1. Check power supply connection
	1.2. Float switch does not switch on	1.2. Raise position of the float switch
2. Insufficient flow / no flow	2.1. Reduced pumping capacity by dirty and abrasive water	2.1. Clean product or have worn-out parts replaced
	2.2. Hose / pipe is clogged	2.2. Unclog hose / pipe
	2.3. Hose / pipe system is damaged	2.3. Replace it
3. Product does not switch off	3.1. Float switch cannot move down	3.2. Ensure the floating switch can move freely
4. Product switches off after short operating period	4.1. Thermal cut-out stops product due to blockage	4.1. Remove blockage and clean the product
	4.2. Thermal cut-out stops product due to high water temperature	4.2. Make sure that the water temperature of max. 35°C is not exceeded
	4.3. Impeller is caught by foreign substance	4.3. Remove blockage

Recycling and disposal

- > The product comes in a package that protects it against damage during shipping. Keep the package until you are sure that all parts have been delivered and the product is function properly. Recycle the package afterwards.
- > Old products are potentially recyclable under WEEE and do not, therefore, belong in your household rubbish. You are requested to assist us and our contribution to saving resources and protecting the environment by handing in this appliance at an equipped collection centre (if there is one available).



EC declaration of conformity



We
Titan Power Tools (UK) Ltd
Trade House, Mead Avenue, BA22 8RT

Declare that the product
Submersible Pump TTB582PMP
Serial number: from 000001 to 999999

Complies with the essential health and safety requirements of the following directives:

The Low Voltage Directive 2006/95/EC (until 19/04/2016) and
2014/35/EU (from 20/04/2016)

- EN 60335-1:2012+A11:2014
- EN 60335-2-41:2003+A1+A2
- EN 62233:2008

The EMC Directive 2004/108/EC (until 19/04/2016) and
2014/30/EU (from 20/04/2016)

- EN 55014-1/A2:2011
- EN 55014-2/A2:2008
- EN 61000-3-2/A2:2009
- EN 61000-3-3:2008

The RoHS directive 2011/65/EU

Authorised Signatory and Technical File Holder
Date: 08/01/2016

Signature: *P. C. Harries*

Name / title: Peter Harries / Quality Manager

TITAN Power Tools (UK)Ltd. Trade House, Mead Avenue, BA22 8RT



Submersible Pump TTB582PMP