

# TITAN®

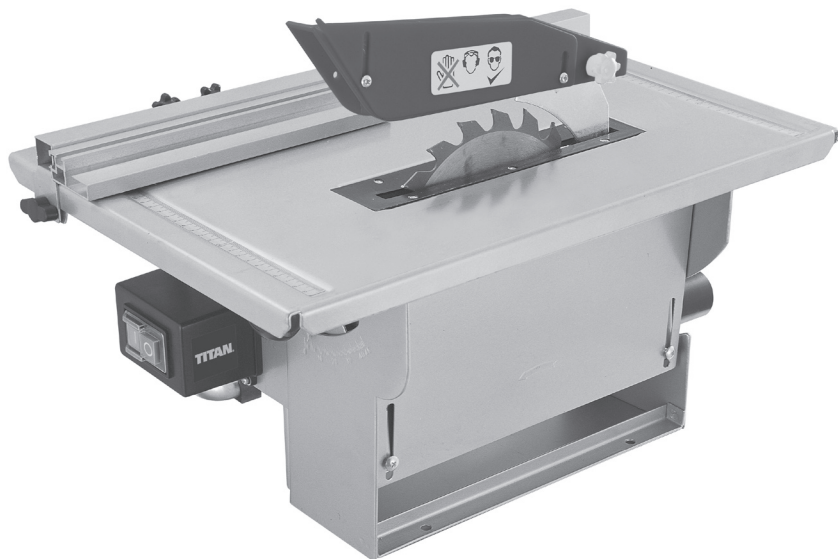

**12** month  
Full  
Manufacturer's  
Warranty

## SAFETY AND OPERATING MANUAL

**8" TABLE SAW**

**SF08N5**

# TITAN®

**Congratulations on your purchase of a TITAN power tool from Screwfix Direct Ltd. We want you to continue getting the best performance from it so this handbook includes information on safety, handling and care. Please retain this handbook in case you need to refer to any of the information in the future.**

**Your TITAN power tool comes with a 12-month guarantee, so should it develop a fault within this period contact Screwfix Direct Ltd on Freephone 0500 41 41 41.**

## **GUARANTEE**

This **TITAN** product carries a Screwfix Direct Ltd guarantee of 12 months. If your product develops a fault within this period, you should, in the first instance contact Screwfix Direct Ltd on Freephone 0500 41 41 41. If the fault occurs within the first 12 months, you may return the goods for a full refund or we will repair or replace the goods if you prefer. When repair is not practical or identical goods are not available, alternative goods of similar specification and quality will usually be provided but, failing this, you will be offered a partial or full refund depending on the time period since purchase.

This guarantee specifically excludes losses caused due to:

- Fair wear and tear
- Misuse or abuse
- Lack of routine maintenance
- Failure of consumable items (such as batteries)
- Accidental damage
- Cosmetic damage
- Failure to follow manufacturer's guidelines
- Loss of use of the goods
- Repairs attempted by anyone, unless authorised by Screwfix Direct Ltd.

This guarantee does not affect your statutory rights. This guarantee is only valid in the UK.

For further technical advice, spare parts or repair service (outside of guarantee) please contact the customer helpline number on 0845 607 6380.

# SAFETY INSTRUCTIONS



**WARNING!** Read all instructions. Failure to follow all instructions listed below may result in electric shock, fire and/or serious injury.

## SAVE THESE INSTRUCTIONS

### 1. **Keep the work area clean.**

Cluttered areas and benches invite injuries.

### 2. **Consider work area environment.**

Do not expose power tools to rain. Do not use power tools in damp or wet locations. Keep the work area well lit. Do not use power tools where there is risk to cause fire or explosion.

### 3. **Guard against electric shock.**

Avoid body contact with earthed or grounded surfaces (e.g. Pipes, radiators, ranges, refrigerators, other metal surfaces).

### 4. **Keep children away.**

Do not let visitors touch the tool or extension cord. All visitors should be away from area.

### 5. **Store idle tools.**

When not in use, tools should be stored in a dry, high or locked up place, out of reach of children.

### 6. **Do not force the tool.**

It will do the job better and safer at the rate for which it was intended.

### 7. **Use the right tool.**

Do not force small tools or attachments to do the job of a heavy-duty tool. Do not use tools for purposes not intended, for example, do not use circular saws to cut tree limbs or logs.

### 8. **Dress properly.**

Do not wear loose clothing or jewellery, they can be caught in moving parts. Rubber gloves and non-skid footwear are recommended when working outdoors. Wear protecting hair covering to contain long hair.

### 9. **Use safety glasses.**

Also use face or dust mask if the cutting operation is dusty.

### 10. **Connect dust extraction equipment.**

If devices are provided for the connection of dust extraction and collection facilities, ensure these are connected and properly used.

### 11. **Do not abuse the cord.**

Never carry the tool by the cord or yank it to disconnect it from the socket. Keep the cord away from heat, oil and sharp edges.

### 12. **Secure work.**

Use clamp or a vice to hold the work. It is safer than using your hand and frees both hands to operate the tool.

### 13. **Do not overreach.**

Keep proper footing and balance at all times.

### 14. **Maintain tool with care.**

Keep cutting tools sharp and clean for better and safer performance. Follow

instructions for lubrication and changing accessories. Inspect tool cord periodically and if damaged have it replaced by an authorised service facility. Inspect extension cords periodically and replace if damaged. Keep handles dry, clean and free of oil or grease.

**15. Disconnect tools.**

When not in use, before servicing and when changing accessories such as blades, bits and cutters, remove the mains plug from the socket.

**16. Remove adjusting keys and wrenches.**

Make the habit of checking to see that keys and adjusting wrenches are hat keys and adjusting wrenches are removed from the tool before turning it on.

**17. Avoid unintentional starting.**

Do not carry a plugged-in tool with a finger on the switch. Ensure switch is in the off when plugging in.

**18. Use outdoor extension leads.**

When tool is used outdoors, use only extension leads approved for outdoor use.

**19. Stay alert.**

Watch what you are doing. Use common sense. Do not operate tool when you are tired or under the influence of drugs or alcohol.

**20. Check damaged parts.**

Before further use of the tool, a guard or other part that is damaged should be carefully checked to determine that it will operate properly and perform its intended function. Check for alignment of moving parts, free running of moving parts, breakage of parts, mounting and any other conditions that may affect its operation. A guard or other part that is damaged should be properly repaired or replaced by an authorised service centre unless otherwise indicated in this instruction manual. Have defective switches replaced by an authorised service facility. Do not use the tool if the switch dose not turn it on and off.

**21. Warning.**

The using of any accessory or attachment, other than those recommended in this instruction manual may present a risk of personal injury.

**22. Have your tools repaired by qualified person.**

This electrical tool is in accordance with the relevant safety requirements. Repairs should only be carried out by qualified persons using original spare parts, otherwise this may result in considerable danger to the user.

**HEALTH ADVICE**



**WARNING!** When drilling, sanding, sawing or grinding, dust particles will be produced. In some instances, depending on the materials you are working with, this dust can be particularly harmful to you (e.g. lead from old gloss paint).

You are advised to consider the risks associated with the materials you are workingwith and to reduce the risk of exposure. You should:

-- Work in a well-ventilated area.

-Work with approved safety equipment, such as those dust masks that are specially designed to filter microscopic particles.

# **ADDITIONAL SAFETY INSTRUCTIONS FOR YOUR TABLE SAW**

1. If the supply cord is damaged have it replaced by a qualified person.
2. Use only saw blades recommended by the manufacturer, which confirm to EN 847-1.
3. Make sure the saw blade is suitable for the material to be cut.
4. Wear suitable personal protective equipment when necessary, this could include
  - a) Hearing protection to reduce the risk of induced hearing loss.
  - b) respiratory protection to reduce the risk of inhalation of harmful dust.
  - c) wear gloves when handling saw blades and rough material.
5. Connect the table saw to a dust collecting device when sawing wood.
6. Do not use High speed steel (HSS) blades.
7. The push-stick or push block should always be stored with the machine when not in use.
8. Safe operation:
  - a) Use push-sticks or push blocks to feed the work-piece past the saw blade.
  - b) Use and ensure correct adjustment of the riving knife.
  - c) Use and ensure correct adjustment of the upper saw blade guard;
  - d) Rebating or grooving should not be carried out unless suitable guarding, such as a tunnel guard, is fitted above the saw table;
  - e) The saw shall not be used for slotting (stopped groove);
  - f) Only use saw blades where the maximum possible speed is not less than the maximum spindle speed of the saw;
  - g) When transporting the machine use only transportation devices and never use guards for handling or transportation;
  - h) During transportation the upper part of the saw blade should be covered; for example by the guard;
  - i) Only use blades with dimensions as shown in these instructions.
  - j) Ensure you support long work pieces;
9. The saw must be firmly secured so that it cannot move whilst being used.
10. Always use the appropriate safety equipment that is required for the product. e.g. Goggles / Safety Spectacles, Ear defenders (essential with tools with a noise rating of over 85dbA), Gloves and face masks. In all cases ensure that the safety equipment is in good condition.

## **SYMBOLS**



Read the manual



Warning



Wear gloves



Wear dust mask, eye & ear protection

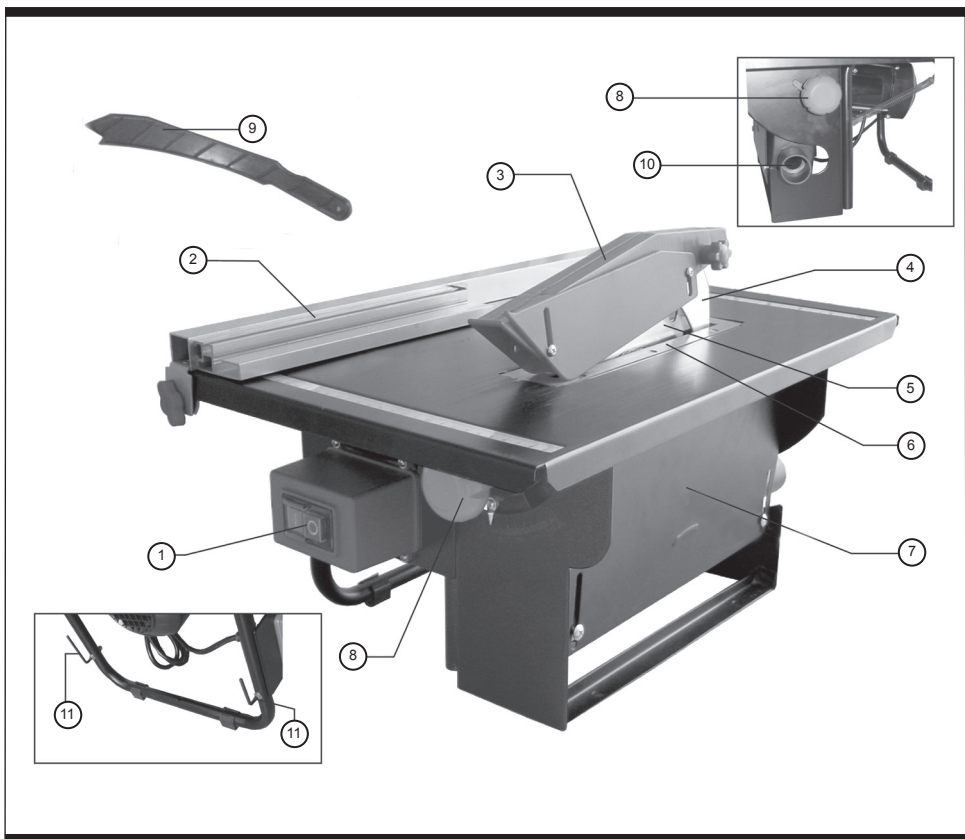

---

**1. ON/OFF SWITCH**

---

**2. RIP FENCE**

---

**3. BLADE GUARD**

---

**4. RIVING KNIFE**

---

**5. BLADE**

---

**6. TABLE INSERT**

---

**7. METAL COVER**

---

**8. BLADE BEVEL SECURING KNOB**

---

**9. PUSH STICK**

---

**10. DUST EXTRACTION OUTLET**

---

**11. HOOKS FOR STORING PUSH STICK**

---

**8" TABLE SAW**

**SF08N5**

## TECHNICAL DATA

---

Voltage:	230V~50Hz
Wattage:	800W S2 30min
No load speed:	2950min <sup>-1</sup>
TCT Blade size:	Ø200x2.4xØ16mm
Depth of cut at 0° :	35mm
Depth of cut at 45° :	24.7mm
Weight:	14kgs
Rated operating time:	on for 30mins,off for 30mins

---

## NOISE EMISSION

---

Sound pressure level:	86.8 dB(A)
Sound power level:	99.8dB(A)

---

## ACCESSORIES

<b>Push rod:</b>	<b>1pc</b>
<b>45 degree angle guide:</b>	<b>1pc</b>
<b>Rip fence:</b>	<b>1pc</b>
<b>Spanner:</b>	<b>2pcs</b>



# OPERATION INSTRUCTIONS

 **Warning:** Before using your table saw, read the instruction manual carefully.

## 1. SECURING THE TABLE SAW

**Note:** Before use, the table saw must be fixed to a stable bench.

If the saw is to be bolted to a workbench you should ensure that it is positioned in the most convenient location. Ensure adequate lighting is available and the electrical supply is close at hand.

A mounting board should be used if a permanent mounting is unavailable or not desired. The board is necessary in order to give the saw stability during operation.

It is recommended that the board dimensions are not less than 450 x 600mm and at least 15mm thick. Once mounted, as described below, the board must be securely clamped to a workbench, using at least two G clamps, one at each side, and a constant check made to ensure they are tight during operation.

To mount the saw, drill three 6mm holes as shown in fig 2, or simply use the machine as a template to mark out the position of the holes, and bolt the machine down with 5mm bolts (not supplied), ensuring flat washers (not supplied) are between the bolt head and base. If a mounting board is used, countersunk holes should be used, with the holes in the underside of the board countersunk to suit.

It is important to ensure the nuts (not supplied) are not over-tightened, and are tightened progressively to avoid distorting the base.

## 2. RIP FENCE

Your table is provided with a rip fence for straight-line cutting and should always be used when rip sawing. The fence is secured to the table with two screws, acting on a pair of clamp plates, one at the front and the other at the rear of the table. The fence may be placed at any suitable position on the table, and either left or right of the saw blade. Do not over-tighten the securing knobs. (See Fig 3) The rip fence supplied with the table saw has two different guide faces. For thick material you

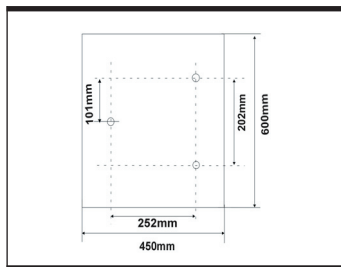

**Fig 2**

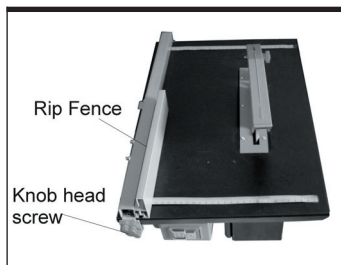

**Fig 3**

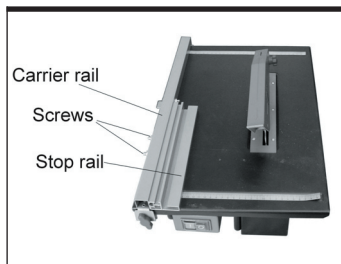

**Fig 4**

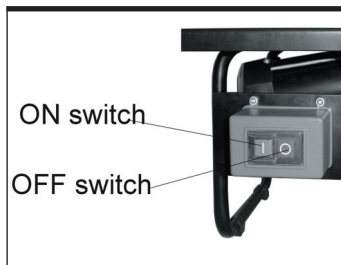

**Fig 5**

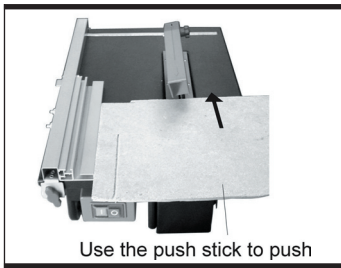

**Fig 6**

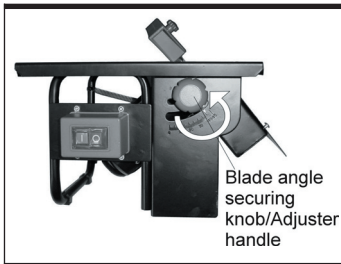

**Fig 7**

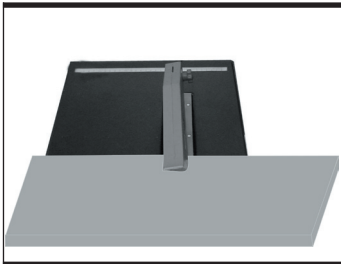

**Fig 8**

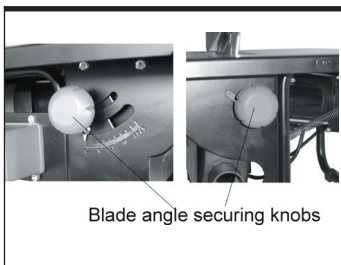

**Fig 9**

may use the stop rail as shown in Fig 3. For thin material you may use the stop rail as shown in Fig 4. To change the height of the stop, slacken the two screws and pull the stop rail off the carrier rail. Turn the stop rail 90° to the left or right, depending on the required height of the stop, and place it back on the carrier rail. Tighten the screws.

### 3. SWITCH

The ON/OFF switch is a no volt release type, i.e. if the power fails or is disconnected while the machine is in use, then the machine will not start when power is restored, and the "I" (ON) button must be pressed to restart. Press "O" (OFF) button to stop. (See Fig 5)

### 4. RIP SAWING

Rip sawing is the term used to describe a cut that is in the same direction as the grain of the wood. For this operation the rip fence should always be used. To rip cut a piece of wood you should proceed as follows: Adjust the rip fence to required width of cut, (i.e. the distance between the edge of the blade and the rip fence,) ensuring it is perfectly parallel to the saw blade.

**Note:** The rip fence can be mounted on the left or right hand side of the blade. Hold work-piece against the rip fence and feed through blade, DO NOT force it, or the motor. Never hold on to the off cut.

If sawing long lengths of material, arrange a support at the rear of the machine, or have an assistant to support the material as it runs off.

### Important!



Always use the push stick (provided) to push the work piece past the saw blade. Do not exceed the rated operating time. (See Fig 6)

### 5. CROSS CUTTING AT AN ANGLE

Cross cutting is the term used to describe a cut, which is across the grain of the wood. This operation is carried out as follows: Remove the rip fence. Slacken the blade angle securing knobs, front and rear. (These are shown in Fig7.) Turn the adjuster handle so that the space table is at the required angle, as indicated by the pointer, then

tighten the securing knobs.

**Note:** If a precision 90° cut is required, check the angle of saw blade using a square, make any adjustments necessary using the adjuster handle, then reset the pointer.

Clearly mark the work-piece where the cut is required. Hold work-piece firmly and feed through saw blade, ensuring feed is straight (DO NOT attempt to cut curves).

If sawing long sections arrange supports at one or both sides of machine as required and not use rip fence. (See Fig 8)

## 6. BEVEL CUTTING

Rip and crosscuts can be made at angles between 0°~45°. Slacken the table angle securing knobs, front and rear (See Fig 9).

Turn the adjuster handle as required to the desired angle as indicated on the scale. Tighten both securing knobs. Proceed to cut as for rip or cross cutting.

## 7. DUST EXTRACTION

This table saw is equipped with a dust extraction port at the rear of the machine (See Fig 10) For safe operation, we recommend that a suitable dust extraction device or vacuum cleaner be connected during operation.

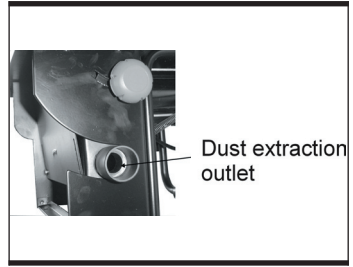

**Fig 10**



**Warning: Excessive sawdust built up around the motor could possibly ignite and cause damage to either the motor, table saw or your workshop.**

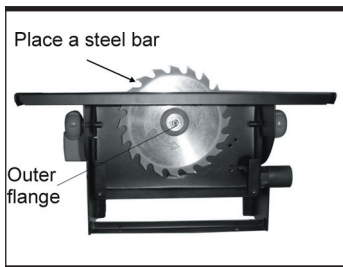

**Fig 11**

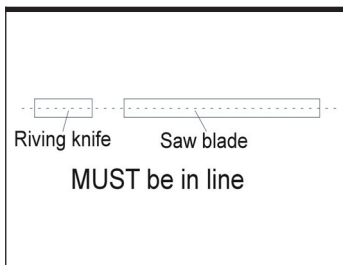

**Fig 12**

## MAINTENANCE



**Warning:** Ensure the machine is disconnected from the main supply BEFORE any maintenance tasks or adjustments are carried out. Your Bench Table Saw requires very little maintenance.

Carrying out those tasks specified below, will not only ensure the maximum safety of operation, but will also prolong the life of your machine.

### AFTER EACH USE:

Sawdust must be removed from the machine.

Remove the side cover by undoing the securing screws, and use a vacuum cleaner to ensure all dust is removed, before replacing the cover.

All plastic components can be wiped clean with a soft dry cloth.

### Keep saw blade sharp:

A blade that is badly dulled or with broken or badly damaged teeth should be replaced immediately.

### To replace the saw blade:

1. Remove the side cover by undoing the securing screws.
2. Place a steel bar or screwdriver blade (not supplied) between the table top and one of the saw blade teeth, (at the point arrowhead in Fig 11). Then undo the saw blade securing nut - normal right hand thread using a suitable spanner (not supplied).
3. Remove the outer flange followed by the saw blade by angling it outwards at the bottom so that it is clear of the motor shaft, and carefully withdrawing it from below.
4. Replace in reverse order ensuring the saw blade teeth face downwards at the front of the table. Hold the blade firmly whilst wearing a good industrial glove when tightening the centre nut, taking care to avoid hurting your hands by the sharp teeth.
5. Make sure the direction arrow on the blade matches the rotational direction of the motor.

### RIVING KNIFE:

The riving knife is an important component and must always be in place and directly in line with the saw blade. It prevents the work from chattering as it passes through the blade. (See Fig 12)

If necessary, remove the Table Insert, then slacken

the two securing screws and adjust accordingly. Ensuring the clearance between the saw blade and riving knife is between 2 and 5mm maximum. Inspect at regular intervals to ensure the gap is correctly maintained, and adjust as required. It may also be necessary to remove the Riving Knife and bend back into shape if it is not exactly in line with the saw blade.

## **ENVIRONMENTAL PROTECTION**



Waste electrical products should not be disposed of with household waste. Please recycle where facilities exist. Check with your Local Authority or retailer for recycling advice.

# PLUG REPLACEMENT

The fuse in the main plug of your power tool should always be replaced with one of identical rating.

Check the voltage given on your power tool matches the supply voltage.

The power tool is supplied with a fitted plug, however if you should need to fit a new plug follows the instruction below.

## IMPORTANT

The wire in the mains lead are coloured in accordance with the following code:

**Green & yellow ---Earth**

**Blue ---Neutral**

**Brown ---Live**

The wire which is coloured green & yellow must be connected to the terminal which is marked with E or  $\frac{1}{\text{E}}$ .

The wire that is coloured blue must be connected to the terminal that is marked with the letter N.

The wire that is coloured brown must be connected to the terminal that is marked with the letter L.

A 13AMP (BS1363 or BS1363/A) plug must be used and a 13 AMP fuse must be fitted.

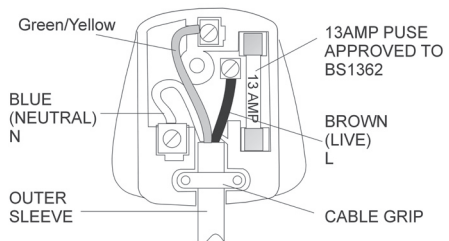

# SCREWFIX DIRECT®

## Declaration of Conformity

We, Importer

**Screwfix Direct Ltd**

**Mead Avenue**

**Houndstone Business Park**

**Yeovil**

**BA 22 8RT**

Declare that the product

**TABLE SAW**

**SF08N5**

Complies with the essential health and safety requirements of the following directives:

**89/336 EEC, 93/68 EEC**—EMC Directive.

**73/23 EEC, 93/68 EEC**—Low Voltage Directive

**98/37 EC**—Machinery Directive.

Standards and technical specifications referred to:

**EN 61029-1:2000/+A11:2003/+A12:2003**

**EN 61029-2-1:2002**

**EN 55014-1:2000/+A1:2001/+A2:2002**

**EN 55014-2:1997/+A1:2001**

**EN 61000-3-2:2000**

**EN 61000-3-3:1995/+A1:2001**

### Authorised Signatory

Date: 03/15/05

Signature: P. C. Harries

Name: Peter Harries  
Screwfix Direct Ltd  
Quality Manager



2005

**8" TABLE SAW**

**SF08N5**

**TITAN®**